

radio handbook

nineteenth edition

William I. Orr, W6SAI



radio handbook

eighteenth edition

William I. Orr, W6SAI



EDITORS and ENGINEERS, LTD.

New Augusta, Indiana

**EIGHTEENTH EDITION
FIRST PRINTING — 1970**

RADIO HANDBOOK

**Copyright © 1970 by Editors and Engineers, Ltd., New Augusta,
Indiana. Printed in the United States of America.**

**All rights reserved. Reproduction or use, without express
permission, of editorial or pictorial content, in any manner,
is prohibited. No patent liability is assumed with respect to
the use of the information contained herein.**

Library of Congress Catalog Card Number: 40-33904

"Radio Handbook" is also available on special order in Spanish.

PREFACE

The publishers are pleased to present this new, revised eighteenth edition of the *RADIO HANDBOOK*. Growing from a slim paperback volume first printed in 1935, the *RADIO HANDBOOK* has reached its present position as an authority in the field of high-frequency and vhf radio communication. This edition continues as the leading handbook in radio communications in a period when high-frequency and vhf techniques and practices are in a state of rapid change and development.

During the present decade, single sideband has been accepted as the favored mode for high-frequency communication and solid-state techniques are rapidly replacing the vacuum tube in receiving and low-power transmitting equipment. Compact transceivers, desk-top linear amplifiers, and solid-state power supplies are commonplace in the modern amateur station. Coming into widespread popularity are radioteletype and the use of frequency modulation on the very-high frequencies. Amplitude modulation has been eclipsed on the high-frequency bands and seemingly will be replaced by frequency modulation for improved performance on the bands above 50 MHz. Triband beam antennas have largely replaced monoband arrays and dipoles on the higher frequencies, and the new log-periodic yagi antenna shows great promise for vhf work.

The author is pleased to note that the *RADIO HANDBOOK* has been a leader in advancing the state of the art of these varied radio amateur developments, many of which are reflected in this new edition of the Handbook. A feature of interest to all amateurs is the solid-state, high-frequency receiver, designed for SSB and c-w service, utilizing field-effect transistors and integrated circuitry. Advanced SSB linear amplifier designs and low-noise vhf converters are other up-to-date items featured in this edition.

This new edition typifies the modern trend in amateur radio toward more advanced and sophisticated equipment. To those individuals and organizations whose unselfish assistance and valued support made the compilation and publication of this Handbook an interesting and inspired task, I extend my thanks and appreciation.

WILLIAM I. ORR, W6SAI

Acknowledgements

W. W. Eitel,
W6UF/WA7LRU
Mike Goldstein, VE3GFN
Robert Grace, W6VQV
Wm. S. Grenfell, W4GF
John Holmbeck, W9KZO
Ozzie Jaeger, W3EB/6
J. McCullough, W6CHE

B.A. Ontiveros, W6FFF
Ken L. Pierce, W6SLQ
Raymond Rinaudo, W6ZO
Mike Staal, K6MYC
Robert Stein, WA6QIC
Robert Sutherland, W6UOV
Robert Walton, W6CYL

Robert Welborn, W9PBW
Paul Wilson, W4HHK
Eimac division of Varian
J. W. Miller Co.
Northern Engineering
Laboratories
Stancor Electronics, Inc.
Triad Transformer Co.

Contents

Glossary of Terms	11
Chapter One. INTRODUCTION TO RADIO	13
1-1 Amateur Radio	13
1-2 Station and Operator Licenses	14
1-3 The Amateur Bands	16
1-4 Starting Your Study	18
Chapter Two. DIRECT-CURRENT CIRCUITS	26
2-1 The Atom	26
2-2 Fundamental Electrical Units and Relationships	27
2-3 Electrostatics and Capacitors	36
2-4 Magnetism and Electromagnetism	42
2-5 RC and RL Transients	47
Chapter Three. ALTERNATING-CURRENT CIRCUITS	50
3-1 Alternating Current	50
3-2 Resonant Circuits	64
3-3 Nonsinusoidal Waves and Transients	70
3-4 Transformers	73
3-5 Electric Filters	76
3-6 Low-Pass Filter Nomographs	78
Chapter Four. VACUUM-TUBE PRINCIPLES	83
4-1 Thermionic Emission	83
4-2 The Diode	88
4-3 The Triode	89
4-4 Tetrode or Screen-Grid Tubes	94
4-5 Mixer and Converter Tubes	97
4-6 Electron Tubes at Very-High Frequencies	98
4-7 Special Microwave Electron Tubes	99
4-8 The Cathode-Ray Tube	102
4-9 Gas Tubes	105
4-10 Miscellaneous Tube Types	107
Chapter Five. SEMICONDUCTOR DEVICES	108
5-1 Atomic Structure of Germanium and Silicon	108
5-2 Mechanism of Conduction	109

5-3	The PN Junction	110
5-4	The Transistor	116
5-5	Transistor Characteristics	120
5-6	Transistor Circuitry	124
5-7	The Field-Effect Transistor	133
5-8	Integrated Circuits	135
5-9	Silicon Power Transistors	136
Chapter Six. VACUUM-TUBE AMPLIFIERS		142
6-1	Vacuum-Tube Parameters	142
6-2	Classes and Types of Vacuum-Tube Amplifiers	143
6-3	Biasing Methods	144
6-4	Distortion in Amplifiers	145
6-5	Resistance-Capacitance Coupled Audio-Frequency Amplifiers	145
6-6	Video-Frequency Amplifiers	149
6-7	Other Interstage Coupling Methods	149
6-8	Phase Inverters	152
6-9	D-C Amplifiers	154
6-10	Single-Ended Triode Amplifiers	154
6-11	Single-Ended Pentode Amplifiers	157
6-12	Push-Pull Audio Amplifiers	158
6-13	Class-B Audio-Frequency Power Amplifiers	160
6-14	Cathode-Follower Power Amplifiers	165
6-15	Feedback Amplifiers	166
Chapter Seven. RADIO-FREQUENCY POWER AMPLIFIERS		169
7-1	Class-C R-F Power Amplifiers	169
7-2	Constant-Current Curves	173
7-3	Class-C Amplifier Calculations	175
7-4	Class-B Radio-Frequency Power Amplifiers	180
7-5	Grounded-Grid and Cathode-Follower R-F Power Amplifier Circuits ..	183
7-6	Class-AB ₁ Radio-Frequency Power Amplifiers	187
7-7	Grounded-Grid Linear Amplifiers	190
7-8	Intermodulation Distortion	193
Chapter Eight. THE OSCILLOSCOPE		195
8-1	A Modern Oscilloscope	195
8-2	Display of Waveforms	199
8-3	Lissajous Figures	201
8-4	Monitoring Transmitter Performance with the Oscilloscope	204
8-5	Receiver I-F Alignment with an Oscilloscope	205
8-6	Single-Sideband Applications	208
Chapter Nine. SPECIAL CIRCUITRY FOR VACUUM TUBES AND SEMICONDUCTORS		211
9-1	Limiting Circuits	211
9-2	Clamping Circuits	214
9-3	Multivibrators	214
9-4	The Blocking Oscillator	216
9-5	Counting Circuits	216
9-6	Resistance-Capacitance Oscillators	217
9-7	Feedback	218

Chapter Ten. RADIO RECEIVER FUNDAMENTALS	220
10-1 Detection or Demodulation	220
10-2 Superheterodyne Receivers	222
10-3 Noise and Spurious Products	226
10-4 Plate-Circuit Considerations	228
10-5 R-F Stages	230
10-6 Signal-Frequency Tuned Circuits	233
10-7 I-F Circuits	236
10-8 Detector, Audio, and Control Circuits	243
10-9 Noise Suppression	246
10-10 Special Considerations in UHF Receiver Design	250
10-11 Receiver Adjustment	254
10-12 Receiving Accessories	256
Chapter Eleven. GENERATION OF RADIO-FREQUENCY ENERGY	258
11-1 Self-Controlled Oscillators	258
11-2 Quartz-Crystal Oscillators	264
11-3 Crystal Oscillator Circuits	265
11-4 Radio-Frequency Amplifiers	273
11-5 Neutralization of R-F Amplifiers	274
11-6 Neutralizing Procedures	277
11-7 Grounded-Grid Amplifiers	281
11-8 Frequency Multipliers	281
11-9 Tank-Circuit Capacitances	284
11-10 L- and Pi-Matching Networks	288
11-11 Grid Bias	292
11-12 Protective Circuits for Tetrode Transmitting Tubes	294
11-13 Interstage Coupling	296
11-14 Radio-Frequency Chokes	297
11-15 Parallel and Push-Pull Tube Circuits	298
11-16 Cooling Transmitting Tubes	299
Chapter Twelve. R-F FEEDBACK	301
12-1 R-F Feedback Circuits	301
12-2 Feedback and Neutralization of a Two-Stage R-F Amplifier	304
12-3 Neutralization Procedure in Feedback-Type Amplifiers	306
Chapter Thirteen. AMPLITUDE MODULATION AND AUDIO PROCESSING	309
13-1 Sidebands	309
13-2 Mechanics of Modulation	310
13-3 Systems of Amplitude Modulation	312
13-4 Input Modulation Systems	318
13-5 Cathode Modulation	323
13-6 The Doherty and Terman-Woodyard Modulated Amplifiers	323
13-7 Speech Clipping	325
13-8 Speech Compression	330
Chapter Fourteen. FREQUENCY AND PHASE MODULATION	334
14-1 Frequency Modulation	334
14-2 Direct F-M Circuits	339
14-3 Phase Modulation	342
14-3 Reception of F-M Signals	345

Chapter Fifteen. RADIOTELETYPE SYSTEMS	353
15-1 Radioteletype Systems	353
15-2 RTTY Reception	354
15-3 Frequency-Shift Keying	356
Chapter Sixteen. SINGLE-SIDEBAND TRANSMISSION AND RECEPTION	359
16-1 The SSB System	359
16-2 A Basic Single-Sideband Transmitter	367
16-3 The Balanced Modulator	368
16-4 The Sideband Filter	370
16-5 The Phasing Type SSB Exciter	372
16-6 Single-Sideband Frequency Conversion	377
16-7 Distortion Products Due to Nonlinearity of Amplifiers	382
16-8 Automatic Load Control and Speech Compression	383
16-9 Basic SSB Exciters	386
16-10 SSB Reception	391
16-11 The SSB Transceiver	394
Chapter Seventeen. EQUIPMENT DESIGN	396
17-1 Resistors	396
17-2 Capacitors	398
17-3 Wire and Inductors	400
17-4 Grounds	402
17-5 Holes, Leads, and Shafts	403
17-6 Parasitic Resonances	404
17-7 Parasitic Oscillation in R-F Amplifiers	405
17-8 Elimination of VHF Parasitic Oscillations	407
17-9 Checking for Parasitic Oscillations	409
17-10 Forced-Air Cooling	411
Chapter Eighteen. RADIO INTERFERENCE	412
18-1 Types of Television Interference	412
18-2 Harmonic Radiation	414
18-3 Low-Pass Filters	416
18-4 Broadcast Interference	421
18-5 Miscellaneous Interference	425
Chapter Nineteen. STATION ASSEMBLY AND CONTROL	427
19-1 Station Layout	427
19-2 Transmitter Control Methods	432
19-3 Safety Precautions	434
19-4 Transmitter Keying	437
19-5 Cathode Keying	438
19-6 Grid-Circuit Keying	439
19-7 Screen-Grid Keying	440
19-8 Differential Keying Circuits	442
19-9 VOX Circuitry	444
Chapter Twenty. RADIATION, PROPAGATION, AND TRANSMISSION LINES ..	447
20-1 Radiation from an Antenna	447
20-2 General Characteristics of Antennas	448
20-3 Radiation Resistance and Feed-Point Impedance	452
20-4 Antenna Directivity	455

20-5	Bandwidth	458
20-6	Propagation of Radio Waves	458
20-7	Ground-Wave Communication	459
20-8	Ionospheric Propagation	462
20-9	Transmission Lines	466
20-10	Nonresonant Transmission Lines	467
20-11	Tuned or Resonant Lines	470
20-12	Line Discontinuities	471
20-13	A Broadband 50-Ohm Balun	472
Chapter Twenty-One. ANTENNAS AND ANTENNA MATCHING		473
21-1	End-Fed Half-Wave Horizontal Antennas	473
21-2	Center-Fed Half-Wave Horizontal Antennas	474
21-3	The Half-Wave Vertical Antenna	477
21-4	The Ground-Plane Antenna	478
21-5	The Marconi Antenna	479
21-6	Space-Conserving Antennas	481
21-7	Multiband Antennas	483
21-8	Matching Nonresonant Lines to the Antenna	493
21-9	Antenna Supports	499
21-10	Coupling to the Antenna System	502
21-11	Antenna Couplers	505
21-12	A Single-Wire Antenna Tuner	507
21-13	A Tuner for Center-Fed Antenna Systems	509
Chapter Twenty-Two. HIGH-FREQUENCY DIRECTIVE ANTENNAS		512
22-1	Directive Antennas	512
22-2	Long-Wire Radiators	514
22-3	The V Antenna	515
22-4	The Rhombic Antenna	517
22-5	Stacked-Dipole Arrays	519
22-6	Broadside Arrays	521
22-7	The Cubical Quad Beam	526
22-8	End-Fire Directivity	528
22-9	Combination End-Fire and Broadside Arrays	529
Chapter Twenty-Three VHF AND UHF ANTENNAS		532
23-1	Antenna Requirements	532
23-2	Simple Horizontally Polarized Antennas	535
23-3	Simple Vertical-Polarized Antennas	536
23-4	The Discone Antenna	539
23-5	Helical Beam Antennas	540
23-6	The Corner-Reflector and Horn-Type Antennas	542
23-7	VHF Horizontal Rhombic Antenna	544
23-8	The Log-Periodic Antenna	545
23-9	VHF Yagi Beam Antennas	548
Chapter Twenty-Four. HIGH-FREQUENCY ROTARY-BEAM ANTENNAS		555
24-1	Unidirectional Parasitic End-Fire Arrays (Yagi Type)	555
24-2	The Three-Element Array	557
24-3	Feed Systems for Parasitic (Yagi) Arrays	559
24-4	Unidirectional Driven Arrays	565
24-5	Construction of Rotatable Arrays	568

24-6	Tuning the Array	569
24-7	Indication of Direction	571
24-8	Three-Band Beams	572
24-9	Lumped Baluns for Beam Antennas	573
Chapter Twenty-Five. MOBILE EQUIPMENT AND INSTALLATION		575
25-1	Mobile Converters	575
25-2	Mobile Power Sources	577
25-3	Transistor Supplies	580
25-4	Antennas for Mobile Work	585
25-5	Construction of Mobile Equipment	589
25-6	Vehicular Noise Suppression	591
25-7	A Printed-Circuit SSB Transceiver	593
25-8	A 200-Watt 3-Band Sideband Transceiver	601
Chapter Twenty-Six. RECEIVERS AND TRANSCEIVERS		613
26-1	A General-Purpose High-Frequency Converter	614
26-2	A Low-Noise MOSFET Converter for 2 Meters	619
26-3	An FET Converter for 144 MHz	624
26-4	An FET Converter and R-F Amplifier for 432 MHz	629
26-5	A Solid-State Amateur Band Receiver	634
26-6	A Single-Band SSB Transceiver	645
Chapter Twenty-Seven. EXCITERS AND STATION ACCESSORIES		657
27-1	A General-Purpose Exciter For 6 Meters	657
27-2	A 40-Watt Broadband Exciter For 2 Meters	661
27-3	A 2-Meter SSB Transverter	667
27-4	A 150-Watt PEP Linear Amplifier For 2 Meters	675
27-5	A Triple/Amplifier For 432 MHz	680
27-6	A 175-Watt SSB Exciter	683
27-7	Audio Filters For SSB and C-W Reception	693
Chapter Twenty-Eight. H-F AND VHF POWER AMPLIFIERS		696
28-1	Triode Amplifier Design	697
28-2	Tetrode Amplifier Design	701
28-3	Cathode-Driven Amplifier Design	709
28-4	1-kW Economy Linear Amplifier	714
28-5	The KW-1 All Band Linear Amplifier Using Two 4CX300A's	719
28-6	The 500Z 2-kW PEP Linear Amplifier for 10 thru 80 Meters	725
28-7	The Triband KW-2 Linear Amplifier For 20, 15, and 10 Meters	734
28-8	A Two-Stage High-Gain Amplifier Using The 3-1000Z	740
28-9	A Kilowatt Linear Amplifier for Six Meters	747
Chapter Twenty-Nine. SPEECH AND AMPLITUDE-MODULATION EQUIPMENT		753
29-1	Modulation	753
29-2	General-Purpose Tetrode Modulators	756
29-3	General-Purpose Triode Class-B Modulator	758
29-4	A 15-Watt Clipper-Amplifier	760
29-5	Auxiliary Clipper-Amplifiers	761
Chapter Thirty- POWER SUPPLIES		763
30-1	Power-Supply Requirements	763

30-2	Power-Supply Components	767
30-3	Rectification Circuits	768
30-4	The Silicon Rectifier	775
30-5	Series Diode Operation	777
30-6	Silicon Supplies for SSB	778
30-7	A 1-Kilowatt IVS Power Supply	783
30-8	A 2-Kilowatt PEP Supply for SSB	784
30-9	IVS Bridge-Rectifier Supplies	784
30-10	Regulated Power Supplies	787
30-11	General-Purpose Power Supplies	790
Chapter Thirty-One. ELECTRONIC TEST EQUIPMENT		797
31-1	Voltage and Current	797
31-2	The Vacuum-Tube Voltmeter	800
31-3	Solid-State Voltmeters	805
31-4	Power Measurements	806
31-5	Measurement of Circuit Constants	808
31-6	Measurements with a Bridge	809
31-7	R-F Bridges	811
31-8	Antenna and Transmission-Line Instrumentation	812
31-9	Practical SWR Instruments	816
31-10	Frequency and Time Measurements	821
31-11	Instruments for Shop and Station	822
Chapter Thirty-Two. WORKSHOP PRACTICE		829
32-1	Tools	829
32-2	The Material	831
32-3	TVI-Proof Inclosures	833
32-4	Inclosure Openings	833
32-5	Summation of the Problem	834
32-6	Construction Practice	834
32-7	Printed Circuits	838
32-8	Coaxial Cable Terminations	839
32-9	Shop Layout	840
32-10	Components and Hardware	841
Chapter Thirty-Three. RADIO MATHEMATICS AND CALCULATIONS		873
Appendix		885
Index		889

GLOSSARY OF TERMS

Symbol	Notation	Symbol	Notation
A	Amperes (a-c, rms, or d-c)	fil	Filament
A	Amplifier voltage gain	G	Giga (10 ⁹)
a	Amperes (peak)	g, g ₁ , g ₂ , etc.	Grid (number to identify, starting from cathode)
ac, a-c, a.c.	Alternating current	g _{2:1}	Grids having common pin connection
a-m, a.m.	Amplitude modulation	GHz	Gigahertz (10 ⁹ cycles per second)
C	Capacitance	G _m or S _m	Transconductance (grid-plate)
c.f.m.	Cubic feet per minute	H	Henry
C _{cg}	Capacitance grid to ground	Hz	Hertz
C _{ck} , C _{cp} , etc.	Tube capacitance between indicated electrodes	<i>i</i>	Peak current
C _{in}	Input capacitance	<i>I</i>	Current (a-c, rms, or d-c)
C _k	Capacitance between cathode and ground	<i>I_b</i>	Average d-c plate current
cm	Centimeter	<i>I_{b max}</i>	Peak signal d-c plate current
C _N	Neutralizing capacitance	<i>i_b</i>	Instantaneous plate current
C _{out}	Output capacitance	<i>I_{b max}</i>	Peak plate current
C _{ps2}	Capacitance, plate to screen	<i>I_{bo}</i>	Idling plate current
cw, c.w. or c-w	Continuous wave	<i>I_c</i>	Average d-c grid current
dB or db	Decibel	<i>i_p</i>	Instantaneous a-c plate current referred to <i>I_b</i>
dc, d.c., d-c	Direct current	<i>i_{p max}</i>	Peak a-c plate current referred to <i>I_b</i>
<i>E</i>	Voltage (a-c, rms, or d-c)	<i>I₁ etc.</i>	Fundamental component of r-f plate current
<i>e</i>	Peak voltage	<i>I_{1 max}</i>	Peak fundamental component of r-f plate current
<i>E₁</i>	Average plate voltage	<i>I₁</i>	Single tone d-c plate current
<i>e₁</i>	Instantaneous plate voltage	<i>I₂ etc.</i>	Two-tone, etc., d-c plate current
<i>e_{1 max}</i>	Peak plate voltage	<i>I_{1, 2, etc.}</i>	Average grid #1, #2, etc. current
<i>e_{1 min}</i>	Minimum instantaneous plate voltage referenced to ground	<i>I_f</i>	Filament current
<i>e_{1 max}</i>	Maximum positive grid voltage	<i>i_{g1}, i_{g2} etc.</i>	Instantaneous grid current
<i>E₁₀</i>	Cutoff-bias voltage	<i>i_{g1 max}, etc.</i>	Peak grid current
<i>E₁₁</i>	Average grid #1 voltage	<i>I_k</i>	Average cathode current
<i>E₁₂</i>	Average grid #2 voltage	<i>i_k</i>	Instantaneous cathode current
<i>E₁₃</i>	Average grid #3 voltage	<i>I_{k max}</i>	Peak cathode current
<i>e₁₁</i>	Instantaneous grid #1 voltage	K	Kathode
<i>e₁₂</i>	Instantaneous grid #2 voltage	k	Kilo(10 ³)
<i>e₁₃</i>	Instantaneous grid #3 voltage	kHz	Kilohertz
<i>E_f</i>	Filament voltage	kV	Peak kilovolts
<i>e_c</i>	Rms value of exciting voltage	kVac	A-c kilovolts
<i>e_p</i>	Instantaneous plate voltage (a.c.) referenced to <i>E₁₁</i>	kVdc	D-c kilovolts
<i>e_{p max}</i>	Peak a-c plate voltage referenced to <i>E₁₁</i>	kW	Kilowatts
<i>E_{s12}</i>	Applied signal voltage (d-c)	λ	Wavelength
<i>e_{s12}</i>	Applied signal voltage (a-c)	M	Mutual inductance
<i>e_k</i>	Instantaneous cathode voltage	M	Mega (10 ⁶)
<i>e_{k max}</i>	Peak cathode voltage	m	Meter
F	Farad	m	One thousandth
f	Frequency (in Hertz)		

Symbol	Notation	Symbol	Notation
mm	Millimeter	R_p	Resistance in series with plate
mA or ma	Milliamperes	r_p	Dynamic internal plate resistance
Meg or meg	Megohm	S _c or G _c	Conversion transconductance
mH	Millihenry	S _m or G _m	Transconductance
MHz	Megahertz	SSB	Single sideband
Mu or μ	Amplification factor	SWR	Standing-wave ratio
mV or mv	Millivolts	T	Temperature (°C)
MW	Megawatts	t	Time (seconds)
mW	Milliwatts	θ	Conduction angle
NF	Noise figure	μ	Micro (10 ⁻⁶) or amplification factor
N_p	Efficiency	μ	Amplification Factor
p	Pico (10 ⁻¹²)	μ A	Microampere
P_{d1}	Average drive power	μ mho	Micromho
p_{d1}	Peak drive power	μ F or μ fd	Microfarad
P_{r1}	Average feedthrough power	μ H	Microhenry
p_{r1}	Peak feedthrough power	μ s	Microsecond
pF or pf	Picofarad	μ V	Microvolt
PEP	Peak envelope power	μ :	Grid-screen amplification factor
$P_{c1}, P_{c2}, \text{etc.}$	Power dissipation of respective grids	V	Volt(s), (a-c, rms, or d-c) or d.c.)
P_i	Power input (average)	v	Peak volts
p_i	Peak power input	Vac	A-c volts
P_o	Power output (average)	Vdc	D-c volts
p_o	Peak power output	VSWR	Voltage standing-wave ratio
P_p	Plate dissipation	W	Watts
Q	Figure of merit	Z	Impedance
Q_1	Loaded Q	Z_g	Grid impedance
R	Resistance	Z_i	Input impedance
r	Reflector	Z_c	Cathode impedance
rf, r.f. or r-f	Radio frequency	Z_l	Load impedance
R_z	Resistance in series with the grid.	Z_o	Output impedance
r_z	Dynamic internal grid resistance	Z_p	Impedance in plate circuit
R_k	Resistance in series with the cathode	Z_s	Screen bypass impedance
R_L	Load resistance		
rms	Root mean square		

Introduction to Radio

The field of *radio* is a division of the much larger field of electronics. Radio itself is such a broad study that it is still further broken down into a number of smaller fields of which only short-wave or high-frequency radio is covered in this book. Specifically the field of communication on frequencies from 1.8 to 450 MHz is taken as the subject matter for this work.

The largest group of persons interested in the subject of high-frequency communication is the more than 450,000 radio amateurs located in nearly all countries of the world. Strictly speaking, a *radio amateur* is anyone noncommercially interested in radio, but the term is ordinarily applied only to those hobbyists possessing transmitting equipment and a license to operate from the Government.

It was for the radio amateur, and particularly for the serious and more advanced amateur, that most of the equipment described in this book was developed. However, in each equipment group, simple items also are shown for the student or beginner. The design principles behind the equipment for high-frequency radio communication are of course the same whether the equipment is to be used for commercial, military, or amateur purposes. The principal differences lie in construction practices, and in the tolerances and safety factors placed on components.

With the increasing complexity of high-frequency communication, resulting primarily from increased utilization of the

available spectrum, it becomes necessary to delve more deeply into the basic principles underlying radio communication, both from the standpoint of equipment design and operation and from the standpoint of signal propagation. Hence, it will be found that this edition of the **RADIO HANDBOOK** has been devoted in greater proportion to the teaching of the principles of equipment design and signal propagation. It is in response to requests from schools and agencies of the Department of Defense, in addition to persistent requests from the amateur radio fraternity, that coverage of these principles has been expanded.

1-1 Amateur Radio

Amateur radio is a fascinating hobby with many facets. So strong is the fascination offered by this hobby that many executives, engineers, and military and commercial operators enjoy amateur radio as an avocation, even though they are also engaged in the radio field commercially. It captures and holds the interest of many people in all walks of life, and in all countries of the world where amateur activities are permitted by law.

Amateurs have rendered much public service through furnishing communications to and from the outside world in cases where disaster has isolated an area by severing all wire communications. Amateurs have

a proud record of heroism and service on such occasions. Many expeditions to remote places have been kept in touch with home by communication with amateur stations on the high frequencies. The amateur's fine record of performance with the "wireless" equipment of World War I has been surpassed by his outstanding service in World War II.

By the time peace came in the Pacific in the summer of 1945, many thousand amateur operators were serving in the Allied Armed Forces. They had supplied the Army, Navy, Marines, Coast Guard, Merchant Marine, Civil Service, war plants, and civilian defense organizations with *trained* personnel for radio, radar, wire, and visual communications and for teaching. Even now, at the time of this writing, amateurs are being called back into the expanded defense forces, are returning to defense plants where their skills are critically needed, and are being organized into communication units as an adjunct to civil-defense groups.

1-2 Station and Operator Licenses

Every radio transmitting station in the United States no matter how low its power must have a license from the Federal Government before being operated; some classes of stations must have a permit from the government even before being constructed. And every operator of a transmitting station must have an operator's license before operating a transmitter. There are no exceptions. Similar laws apply in practically every major country.

Classes of Amateur Operator Licenses There are at present five classes of amateur operator licenses in the United States authorized by the Federal Communications Commission. These classes differ in many important respects, so each will be discussed briefly.

Novice Class—The Novice Class license is available to any U.S. citizen or national who has not previously held an amateur license of any class issued by any agency of the U.S. Government, military or civilian. The license is valid for a period of two years

and is not renewable. The examination may be taken only by mail, under the direct supervision of an amateur holding a General Class license or higher, or a commercial radiotelegraph licensee. The examination consists of a code test in sending and receiving at a speed of 5 words per minute, plus a written examination on the rules and regulations essential to beginner's operation, including sufficient elementary radio theory for the understanding of these rules. Restricted c-w privileges in segments of the 80-, 40-, and 15-meter amateur bands are currently available to the Novice licensee, whose transmitter is limited to crystal-controlled operation with an input power not exceeding 75 watts.

The receiving code test for the Novice Class license requires correct copy of 25 words of text counting 5 letters per word. No punctuation marks or numerals are included.

Technician Class—The Technician Class exists for the purpose of encouraging a greater interest in experimentation and development of the higher frequencies among experimenters and would-be radio amateurs. This Class of license is available to any U.S. Citizen or national. The examination is similar to that given for the General Class license, except that the code test in sending and receiving is at a speed of 5 words per minute.

The holder of a Technician Class license is accorded all authorized amateur privileges in all amateur bands above 220 MHz, and in portions of the 144-MHz and 50-MHz bands. This class of license may be taken only by mail, under the direct supervision of an amateur holding a General Class license or higher, or a commercial radiotelegraph licensee. The license is valid for a period of five years, and may be renewed on proper application.

General Class—The General Class license is the standard radio amateur license and is available to any U.S. Citizen or national. The license is valid for a period of five years and is renewable on proper application. Applicants for the General Class license must take the examination before an FCC representative (with certain exceptions discussed under the Conditional Class license). The examination consists of a code test

in sending and receiving at a code speed of 13 words per minute, plus a written examination in basic theory and regulations. It conveys all amateur privileges, *with the exceptions noted for the Advanced and Extra Class licenses.*

Conditional Class—The Conditional Class license is equivalent to the General Class license in the privileges accorded by its use. This license is issued to an applicant who: (1) lives more than 175 miles airline distance from the nearest point at which the FCC conducts examinations twice yearly, or oftener; (2) is unable to appear for examination because of physical disability to travel; (3) is unable to appear for examination because of military service; (4) is temporarily resident outside the United States, its territories, or possessions for a year or more. The Conditional Class license may be taken only by mail and is renewable.

Advanced Class—The Advanced Class license is equivalent to the old Class-A license and is available to any U.S. Citizen or national. The license is valid for a period of five years and is renewable on proper application. Applicants for the Advanced Class license must take the examination before an FCC representative. The examination consists of a general code test at 13 words per minute, questions covering general amateur practice and regulations involving radio operation, and technical questions covering intermediate-level radio theory and operation as applicable to modern amateur techniques, including, but not limited to, radiotelephony and radiotelegraphy. An applicant for the Advanced Class license will be given credit for that portion of the examination and the code test covered by the General Class license, if a valid license of that grade is held at the time of examination.

The Advanced Class license accords certain radiotelephone privileges in the amateur bands between 80 and 6 meters, which are unavailable to holders of lower-grade amateur licenses.

Amateur Extra Class—The Amateur Extra Class license is the highest-grade amateur license issued by the FCC and the recipient, on request, may receive a special diploma-type certificate from the District FCC Engineer-in-Charge. The license is valid for a period

of five years and is renewable. Applicants for the Amateur Extra Class license must take the examination before an FCC representative. The examination consists of a code test in sending and receiving at a speed of 20 words per minute, a standard written examination in theory and regulations (credit will be given to holders of General and Advanced Class licenses for this requirement), and a written examination based on advanced radio theory and operation as applicable to modern amateur techniques, including, but not limited to, radiotelephony, radiotelegraphy, and transmissions of energy for measurements and observations applied to propagation, for the radio control of remote objects, and for similar experimental purposes. An applicant for the Amateur Extra Class license will be given credit for that portion of the examination covered by the General and Advanced Class licenses, if a valid license of either grade is held at the time of examination.

The Amateur Extra Class license accords certain radiotelephone and radiotelegraph privileges in the amateur bands between 80 and 6 meters, unavailable to holders of lower-grade licenses. In addition, the holder of an Amateur Extra Class license, licensed for 25 years or longer by the FCC prior to the date of the Amateur Extra Class license may request a two-letter call sign, in lieu of a three-letter call sign.

The Amateur Station License The station license authorizes the radio apparatus of the radio amateur for a particular address and designates the official call sign to be used. The license is a portion of the combined station-operator license normally issued to the radio amateur. Authorization is included for portable or mobile operation within the continental limits of the United States, its territories or possessions, on any amateur frequency authorized to the class of license granted the operator. If portable or mobile operation for a period of greater than 48 hours is contemplated, advance notice must be given to the FCC district in which operation will be conducted. The station license must be modified on a permanent change in address. The station license is customarily renewed with the operator license. Applications filed for ama-

teur radio licenses (except that of a Novice Class) require a filing fee.

International Regulations The domestic regulatory pattern of the United States agrees with the international agreements established by the International Telecommunications Union and to which the United States is a signatory power. The frequency bands reserved for the Amateur Radio Service are included in the ITU frequency allocations table, as one of the services to which frequencies are made available. In the lower-frequency amateur bands, the international allocations provide for joint use of the bands by several services in addition to the amateur service in various areas of the world.

Article I of the ITU Radio Regulations defines the amateur service as: "*A service of self-training, intercommunication, and technical investigations carried on by amateurs, that is, by duly authorized persons interested in radio technique solely with a personal aim and without a pecuniary interest.*" Within this concept, the U. S. radio regulations governing radio amateur licensing and regulation are formulated.

By reciprocal treaty, the United States now has a number of agreements with other countries permitting amateurs of one country to operate in the other. On the other hand, by international agreement, notification to the ITU may forbid international communications with radio amateurs of certain countries.

A comprehensive coverage of United States licensing procedure for radio amateurs and applicable rules and regulations may be found in "*The Radio Amateur's License Manual*," published by the American Radio Relay League, Newington, Conn. 06111.

1-3 The Amateur Bands

Certain small segments of the radio-frequency spectrum between 1500 kHz and 10,000 MHz are reserved for operation of amateur radio stations. These segments are in general agreement throughout the world, although certain parts of different amateur bands may be used for other purposes in various geographic regions. In particular,

the 40-meter amateur band is used legally (and illegally) for short-wave broadcasting by many countries in Europe, Africa and Asia. Parts of the 80-meter band are used for short distance marine work in Europe, and for broadcasting in South America. The amateur bands available to United States radio amateurs are:

160 Meters (1800 kHz—2000 kHz) The 160-meter band is divided into 25-kHz segments on a regional basis, with day and night power limitations, and is available for amateur use provided no interference is caused to the Loran (Long Range Navigation) stations operating in this band. This band is least affected by the 11-year solar sunspot cycle. The *maximum usable frequency* (MUF) even during the years of decreased sunspot activity does not usually drop below 4 MHz, therefore this band is not subject to the violent fluctuations found on the higher-frequency bands. DX contacts on this band are limited by the ionospheric absorption of radio signals, which is quite high. During winter nighttime hours the absorption is often of a low enough value to permit trans-oceanic contacts on this band. On rare occasions, contacts up to 10,000 miles have been made. As a usual rule, however, 160-meter amateur operation is confined to ground-wave contacts or single-skip contacts of 1000 miles or less. Popular before World War II, the 160-meter band is now only sparsely occupied since many areas of the country are blanketed by the megawatt pulses of the Loran chains.

80 Meters (3500 kHz—4000 kHz) The 80-meter band is the most popular amateur band in the continental United States for local "rag chewing" and traffic nets. During the years of minimum sunspot activity the ionospheric absorption on this band may be quite low, and long distance DX contacts are possible during the winter night hours. Daytime operation, in general, is limited to contacts of 500 miles or less. During the summer months, local static and high ionospheric absorption limit long distance contacts on this band. As the sunspot cycle advances and the MUF rises, increased iono-

spheric absorption will tend to degrade the long distance possibilities of this band. At the peak of the sunspot cycle, the 80-meter band becomes useful only for short-haul communication.

40 Meters (7000 kHz—7300 kHz) The 40-meter band is high enough in frequency to be severely affected by the 11-year sunspot cycle. During years of minimum solar activity, the MUF may drop below 7 MHz, and the band will become very erratic, with signals dropping completely out during the night hours. Ionospheric absorption of signals is not as large a problem on this band as it is on 80 and 160 meters. As the MUF gradually rises, the skip distance will increase on 40 meters, especially during the winter months. At the peak of the solar cycle, the daylight skip distance on 40 meters will be quite long, and stations within a distance of 500 miles or so of each other will not be able to hold communication. DX operation on the 40-meter band is considerably hampered by broadcasting stations, propaganda stations, and jamming transmitters. In Europe and Asia the band is in a chaotic state, and amateur operation in this region is severely hampered.

20 meters (14,000 kHz—14,350 kHz) At the present time, the 20-meter band is by far the most popular band for long-distance contacts. High enough in frequency to be almost obliterated at the bottom of the solar cycle, the band nevertheless provides good DX contacts during years of minimal sunspot activity. At the present time, the band is open to almost all parts of the world at some time during the year. During the summer months, the band is active until the late evening hours, but during the winter months the band is only good for a few hours during daylight. Extreme DX contacts are usually erratic, but the 20-meter band is the only band available for DX operation the year around during the bottom of the sunspot cycle. As the sunspot count increases and the MUF rises, the 20-meter band will become open for longer hours during the winter. The maximum skip distance increases, and DX contacts are possible over

paths other than the Great Circle route. Signals can be heard via the "long path," 180 degrees opposite the Great Circle path. During daylight hours, absorption may become apparent on the 20-meter band, and all signals except very short skip may disappear. On the other hand, the band will be open for worldwide DX contacts all night long. The 20-meter band is very susceptible to "fadeouts" caused by solar disturbances, and all except local signals may completely disappear for periods of a few hours to a day or so.

15 Meters (21,000 kHz—21,450 kHz) This is a relatively new band for radio amateurs since it has only been available for amateur operation since 1952. It has characteristics similar to both the 20- and 10-meter amateur bands. During a period of low sunspot activity, the MUF will rarely rise as high as 15 meters, so this band will be "dead" for a large part of the sunspot cycle. During the next few years, 15-meter activity should be excellent, and the band should support extremely long DX contacts. The band will remain open 24 hours a day in Equatorial areas of the world.

Fifteen-meter operation may be hampered in some cases when neighbors possess older-model TV receivers having a 21-MHz i-f channel, which falls directly in the 15-meter band. The interference problem may be alleviated by retuning the i-f system to a frequency outside the amateur assignment.

10 Meters (28,000 kHz—29,700 kHz) During the peak of the sunspot cycle, the 10-meter band is without doubt the most popular amateur band. The combination of long skip and low ionospheric absorption make reliable DX contacts with low-powered equipment possible. The great width of the band (1700 kHz) provides room for a large number of amateurs. The long skip (1500 miles or so) prevents nearby amateurs from hearing each other, thus dropping the interference level. During the winter months, sporadic-E (short-skip) signals up to 1200 miles or so will be heard. The 10-meter band is poorest in the summer months, even during a sunspot maximum. Extreme-

ly long daylight skip is common on this band, and in years of high MUF the 10-meter band will support intercontinental DX contacts during daylight hours.

The second harmonic of stations operating in the 10-meter band falls directly into television channel 2, and the higher harmonics of 10-meter transmitters fall into the higher TV channels. This harmonic problem seriously curtailed amateur 10-meter operation during the late 40's. However, with new circuit techniques and the TVI precautionary measures stressed in this Handbook, 10-meter operation should cause little or no interference to nearby television receivers of modern design.

Six Meters At the peak of the sunspot cycle, the MUF occasionally rises high enough to permit DX contacts up to 10,000 miles or so on 6 meters. Activity on this band during such a period is often quite high. Interest in this band wanes during a period of lesser solar activity, since contacts, as a rule, are restricted to short-skip work. The proximity of the 6-meter band to television channel 2 often causes interference problems to amateurs located in areas where channel 2 is active. As the sunspot cycle increases, activity on the 6-meter band will increase.

The VHF Bands The vhf bands are (Two Meters and "Up") the least affected by the vagaries of the sunspot cycle and Heaviside layer. Their predominant use is for reliable communication over distances of 150 miles or less. These bands are sparsely occupied in the rural sections of the United States, but are quite heavily congested in the urban areas of high population.

In recent years it has been found that vhf signals are propagated by other means than by line-of-sight transmission. "Scatter signals," Aurora reflection, and air-mass boundary bending are responsible for vhf communication up to 1200 miles or so. Weather conditions will often affect long-distance communication on the 2-meter band, and all the vhf bands are particularly sensitive to this condition.

In recent years the vhf bands have been used for experimental "moonbounce" (earth-

moon-earth) transmissions and for repeater-satellite experiments (Project Oscar). The vhf bands hold great promise for serious experimenters as radio amateurs forge into the microwave region.

1-4 Starting Your Study

When you start to prepare yourself for the amateur examination you will find that the circuit diagrams, tube characteristic curves, and formulas appear confusing and difficult to understand. But after a few study sessions one becomes sufficiently familiar with the notation of the diagrams and the basic concepts of theory and operation so that the acquisition of further knowledge becomes easier and even fascinating.

Since it takes a considerable time to become proficient in sending and receiving code, it is a good idea to intersperse technical study sessions with periods of code practice. Many short code-practice sessions benefit one more than a small number of longer sessions. Alternating between one study and the other keeps the student from getting "stale" since each type of study serves as a sort of respite from the other.

When you have practiced the code long enough you will be able to follow the gist of the slower-sending stations. Many stations send very slowly when working other stations at great distances. Stations repeat their calls many times when calling other stations before contact is established, and one need not have achieved much code proficiency to make out their calls and thus determine their location.

The Code The applicant for any class of amateur operator license must be able to send and receive the Continental Code (sometimes called the International Morse Code). The speed required for the sending and receiving test may be either 5, 13, or 20 words per minute, depending on the class of license assuming an average of five characters to the word in each case. The sending and receiving tests run for five minutes, and one minute of errorless transmission or reception must be accomplished within the five-minute interval.

If the code test is failed, the applicant

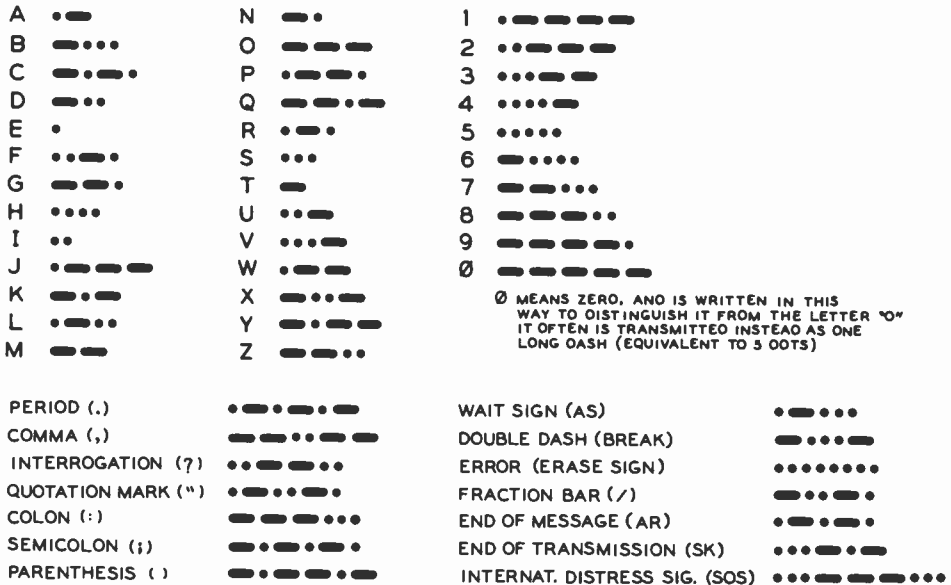

Figure 1

The Continental (or International Morse) Code is used for substantially all non-automatic radio communication. DO NOT memorize from the printed page; code is a language of SOUND, and must not be learned visually; learn by listening as explained in the text.

must wait at least one month before he may again appear for another test. Approximately 30% of amateur applicants fail to pass the test. It should be expected that nervousness and excitement will, at least to some degree, temporarily lower the applicant's code ability. The best insurance against this is to master the code at a little greater than the required speed under ordinary conditions. Then if you slow down a little due to nervousness during a test the result will not prove fatal.

Memorizing the Code There is no shortcut to code proficiency. To memorize the alphabet entails but a few evenings of diligent application, but considerable time is required to build up speed. The exact time required depends on the individual's ability and the regularity of practice.

While the speed of learning will naturally vary greatly with different individuals, about 70 hours of practice (no practice period to be over 30 minutes) will usually suffice to bring a speed of about 13 w.p.m.; 16 w.p.m. requires about 120 hours; 20 w.p.m., 175 hours.

Since code reading requires that individual letters be recognized instantly, any memorizing scheme which depends on orderly sequence, such as learning all "dab" letters and all "dit" letters in separate groups, is to be discouraged. Before beginning with a code practice set it is necessary to memorize the whole alphabet perfectly. A good plan is to study only two or three letters a day and to drill with those letters until they become part of your consciousness. Mentally translate each day's letters into their sound equivalent wherever they are seen, on signs, in papers, indoors and outdoors. Tackle two additional letters in the code chart each day, at the same time reviewing the characters already learned.

Avoid memorizing by routine. Be able to sound out any letter immediately without so much as hesitating to think about the letters preceding or following the one in question. Know C, for example, apart from the sequence ABC. Skip about among all the characters learned, and before very long sufficient letters will have been acquired to enable you to spell out simple words to

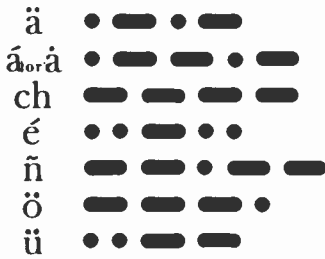

Figure 2

These code characters are used in languages other than English. They may occasionally be encountered so it is well to know them.

yourself in “*dit dabs.*” This is interesting exercise, and for that reason it is good to memorize all the vowels first and the most common consonants next.

Actual code practice should start only when the entire alphabet, the numerals, period, comma, and question mark have been memorized so thoroughly that any one can be sounded without the slightest hesitation. Do not bother with other punctuation or miscellaneous signals until later.

Sound — Each letter and figure *must* be **Not Sight** memorized by its *sound* rather than its appearance. Code is a system of sound communication, the same as is the spoken word. The letter A, for example, is one short and one long sound in combination sounding like *dit dab*, and it must be remembered as such, and not as “dot dash.”

Practice Time, patience, and regularity are required to learn the code properly. Do not expect to accomplish it within a few days.

Don’t practice too long at one stretch; it does more harm than good. Thirty minutes at a time should be the limit.

Lack of regularity in practice is the most common cause of lack of progress. Irregular practice is very little better than no practice at all. Write down what you have heard; then forget it; *do not look back.* If your mind dwells even for an instant on a signal about which you have doubt, you will miss the next few characters while your attention is diverted.

While various automatic code machines, phonograph records, etc., will give you practice, by far the best practice is to obtain a study companion who is also interested in learning the code. When you have both memorized the alphabet you can start sending to each other. Practice with a key and oscillator or key and buzzer generally proves superior to all automatic equipment. Two such sets operated between two rooms are fine—or between your house and his will be just that much better. Avoid talking to your partner while practicing. If you must ask him a question, do it in code. It makes more interesting practice than confining yourself to random practice material.

When two co-learners have memorized the code and are ready to start sending to each other for practice, it is a good idea to enlist the aid of an experienced operator for the first practice session or two so that they will get an idea of how properly formed characters sound.

During the first practice period the speed should be such that substantially solid copy can be made without strain. Never mind if this is only two or three words per minute. In the next period the speed should be increased slightly to a point where nearly all of the characters can be caught only through conscious effort. When the student becomes proficient at this new speed, another slight increase may be made, progressing in this manner until a speed of about 16 words per minute is attained if the object is to pass the amateur 13-word per minute code test. The margin of 3 w.p.m. is recommended to overcome a possible excitement factor at examination time. Then when you take the test you don’t have to worry about the “jitters” or an “off day.”

Speed should not be increased to a new level until the student finally makes solid copy with ease for at least a five-minute period at the old level. How frequently increases of speed can be made depends on individual ability and the amount of practice. Each increase is apt to prove disconcerting, but remember “you are never learning when you are comfortable.”

A number of amateurs are sending code practice on the air on schedule once or twice each week; excellent practice can be obtained after you have bought or con-

structed your receiver by taking advantage of these sessions.

If you live in a medium-size or large city, the chances are that there is an amateur-radio club in your vicinity which offers free code-practice lessons periodically.

Skill When you listen to someone speaking you do not consciously think how his words are spelled. This is also true when you read. In code you must train your ears to read code just as your eyes were trained in school to read printed matter. With enough practice you acquire skill, and from skill, speed. In other words, it becomes a *habit*, something which can be done without conscious effort. Conscious effort is fatal to speed; we can't think rapidly enough; a speed of 25 words a minute, which is a common one in commercial operations, means 125 characters per minute or more than two per second, which leaves no time for conscious thinking.

Perfect Formation of Characters When transmitting on the code practice set to your partner, concentrate on the *quality* of your sending, *not* on your speed. Your partner will appreciate it and he could not copy you if you speeded up anyhow.

If you want to get a reputation as having an excellent "fist" on the air, just remember that speed alone won't do the trick. Proper execution of your letters and spacing will make much more of an impression. Fortunately, as you get so that

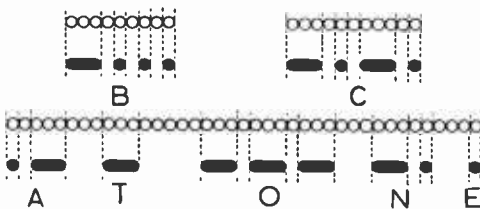

Figure 3

Diagram illustrating relative lengths of dashes and spaces referred to the duration of a dot. A dash is exactly equal in duration to three dots; spaces between parts of a letter equal one dot; those between letters, three dots; space between words, five dots. Note that a slight increase between two parts of a letter will make it sound like two letters.

you can send evenly and accurately, your sending speed will automatically increase. Remember to try to see how *evenly* you can *send*, and how *fast* you can *receive*. Concentrate on making signals properly with your key. Perfect formation of characters is paramount to everything else. Make every signal right no matter if you have to practice it hundreds or thousands of times. Never allow yourself to vary the slightest from perfect formation once you have learned it.

If possible, get a good operator to listen to your sending for a short time, asking him to criticize even the slightest imperfections.

Timing It is of the utmost importance to maintain uniform spacing in characters and combinations of characters. Lack of uniformity at this point probably causes beginners more trouble than any other single factor. Every dot, every dash, and every space must be correctly timed. In other words, accurate timing is absolutely essential to intelligibility, and timing of the spaces between the dots and dashes is just as important as the lengths of the dots and dashes themselves.

The characters are timed with the dot as a "yardstick." A standard dash is three times as long as a dot. The spacing between parts of the same letter is equal to one dot, the space between letters is equal to three dots, and that between words equal to five dots.

The rule for spacing between letters and words is not strictly observed when sending slower than about 10 words per minute for the benefit of someone learning the code and desiring receiving practice. When sending at, say, 5 w.p.m., the individual letters should be made the same as if the sending rate were about 10 w.p.m., except that the spacing between letters and words is greatly exaggerated. The reason for this is obvious. The letter *L*, for instance, will then sound exactly the same at 10 w.p.m. as at 5 w.p.m., and when the speed is increased above 5 w.p.m. the student will not have to become familiar with what may seem to him like a new sound, although it is in reality only a faster combination of dots and dashes. At the greater speed he will merely have to learn the identification of the *same* sound without taking as long to do so.

Be particularly careful of letters like *B*. Many beginners seem to have a tendency to leave a longer space after the dash than that which they place between succeeding dots, thus making it sound like *TS*. Similarly, make sure that you do not leave a longer space after the first dot in the letter *C* than you do between other parts of the same letter: otherwise it will sound like *NN*.

Sending vs. Receiving Once you have memorized the code thoroughly you should concentrate on increasing your *receiving* speed. True, if you have to practice with another newcomer who is learning the code with you, you will both have to do some sending. But don't attempt to practice *sending* just for the sake of increasing your sending speed.

When transmitting code to your partner so that he can practice, concentrate on the *quality* of your sending, not on your speed.

Because it is comparatively easy to learn to send rapidly, especially when no particular care is given to the quality of sending, many operators who have just received their licenses get on the air and send mediocre (or worse) code at 20 w.p.m. when they can barely receive good code at 13. Most old-timers remember their own period of initiation and are only too glad to be patient and considerate if you tell them that you are a newcomer. But the surest way to incur their scorn is to try to impress them with your "lightning speed," and then to request them to send more slowly when they come back to you at the same speed.

Stress your copying ability; never stress your sending ability. It should be obvious that if you try to send faster than you can receive, your ear will not recognize any mistakes which your hand may make.

Using the Key Figure 4 shows the proper position of the hand, fingers and wrist when manipulating a telegraph or radio key. The forearm should rest naturally on the desk. It is preferable that the key be placed far enough back from the edge of the table (about 18 inches) that the elbow can rest on the table. Otherwise, pressure of the table edge on the arm will tend to

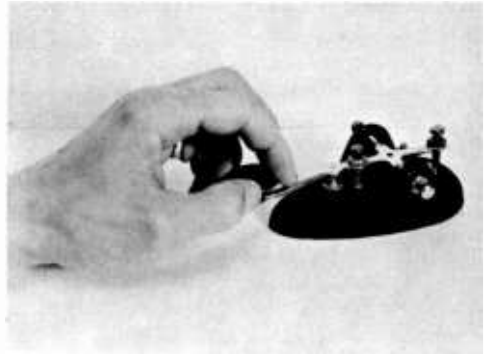

Figure 4

PROPER POSITION OF THE FINGERS FOR OPERATING A TELEGRAPH KEY

The fingers hold the knob and act as a cushion. The hand rests lightly on the key. The muscles of the forearm provide the power, the wrist acting as the fulcrum. The power should not come from the fingers, but rather from the forearm muscles.

hinder the circulation of the blood and weaken the ulnar nerve at a point where it is close to the surface, which in turn will tend to increase fatigue considerably.

The knob of the key is grasped lightly with the thumb along the edge; the index and third fingers rest on the top towards the front or far edge. The hand moves with a free up and down motion, the wrist acting as a fulcrum. The power must come entirely from the arm muscles. The third and index fingers will bend slightly during the sending but not because of deliberate effort to manipulate the finger muscles. Keep your finger muscles just tight enough to act as a cushion for the arm motion and let the slight movement of the fingers take care of itself. The key's spring is adjusted to the individual wrist and should be neither too stiff nor too loose. Use a moderately stiff tension at first and gradually lighten it as you become more proficient. The separation between the contacts must be the proper amount for the desired speed, being somewhat under 1/16 inch for slow speeds and slightly closer together (about 1/32 inch) for faster speeds. Avoid extremes in either direction.

Do not allow the muscles of arm, wrist or fingers to become tense. Send with a full, free arm movement. Avoid like the plague

any finger motion other than the slight cushioning effect mentioned above.

Stick to the regular handkey for learning code. No other key is satisfactory for this purpose. Not until you have thoroughly mastered both sending and receiving at the maximum speed in which you are interested should you tackle any form of automatic or semiautomatic key such as the *Vibroplex* ("bug") or an electronic key.

Difficulties Should you experience difficulty in increasing your code speed after you have once memorized the characters, there is no reason to become discouraged. It is more difficult for some people to learn code than for others, but there is no justification for the contention sometimes made that "some people just can't learn the code." It is not a matter of intelligence; so don't feel ashamed if you seem to experience a little more than the usual difficulty in learning code. Your reaction time may be a little slower or your coordination not so good. If this is the case, remember *you can still learn the code*. You may never learn to send and receive at 40 w.p.m., but you can learn sufficient speed for all noncommercial purposes (and even for most commercial purposes) if you have patience, and refuse to be discouraged by the fact that others seem to pick it up more rapidly.

When the sending operator is sending just a bit too fast for you (the best speed for practice), you will occasionally miss a signal or a small group of them. When you do, leave a blank space; do not spend time futilely trying to recall it; dismiss it, and center attention on the next letter; otherwise you'll miss more. Do not ask the sender any questions until the transmission is finished.

To prevent guessing and get equal practice on the less common letters, depart occasionally from plain language material and use a jumble of letters in which the usually less commonly used letters predominate.

As mentioned before, many students put a greater space after the dash in the letter B, than between other parts of the same letter so it sounds like TS. C, F, Q, V, X, Y, and Z often give similar trouble. Make a list of words or arbitrary combinations in which

these letters predominate and practice them, both sending and receiving until they no longer give you trouble. Stop everything else and stick to them. So long as these characters give you trouble you are not ready for anything else.

Follow the same procedure with letters which you may tend to confuse such as F and L, which are often confused by beginners. Keep at it until you *always* get them right without having to stop *even an instant* to think about it.

If you do not instantly recognize the sound of any character, you have not learned it; go back and practice your alphabet further. You should never have to omit writing down every signal you hear except when the transmission is too fast for you.

Write down what you hear, not what you think it should be. It is surprising how often the word which you guess will be wrong.

Copying Behind All good operators copy several words behind, that is, while one word is being received, they are writing down or typing, say the fourth or fifth previous word. At first this is very difficult, but after sufficient practice it will be found actually to be easier than copying close up. It also results in more accurate copy and enables the receiving operator to capitalize and punctuate copy as he goes along. It is not recommended that the beginner attempt to do this until he can send and receive accurately and with ease at a speed of at least 12 words a minute.

It requires a considerable amount of training to disassociate the action of the subconscious mind from the direction of the conscious mind. It may help some in obtaining this training to write down two columns of short words. Spell the first word in the first column out loud while writing down the first word in the second column. At first this will be a bit awkward, but you will rapidly gain facility with practice. Do the same with all the words, and then reverse columns.

Next try speaking aloud the words in the one column while writing those in the other column; then reverse columns.

After the foregoing can be done easily, try sending with your key the words in one column while spelling those in the other.

Figure 5

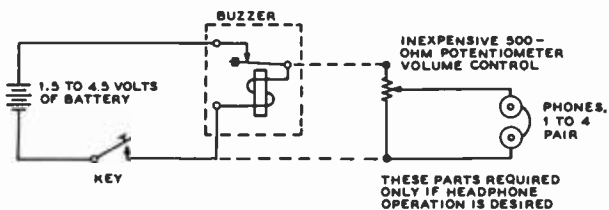

THE SIMPLEST CODE PRACTICE SET CONSISTS OF A KEY AND A BUZZER

The buzzer is adjusted to give a steady, high-pitched whine. If desired, the phones may be omitted, in which case the buzzer should be mounted firmly on a sounding board. Crystal, magnetic, or dynamic ear-phones may be used. Additional sets of phones should be connected in parallel, not in series.

It won't be easy at first, but it is well worth keeping after if you intend to develop any real code proficiency. Do *not* attempt to catch up. There is a natural tendency to close up the gap, and you must train yourself to overcome this.

Next have your code companion send you a word either from a list or from straight text; do not write it down yet. Now have him send the next word; *after* receiving this second word, write down the first word. After receiving the third word, write the second word; and so on. Never mind how slowly you must go, even if it is only two or three words per minute. *Stay behind.*

It will probably take quite a number of practice sessions before you can do this with any facility. After it is relatively easy, then

try staying two words behind; keep this up until it is easy. Then try three words, four words, and five words. The more you practice keeping received material in mind, the easier it will be to stay behind. It will be found easier at first to copy material with which one is fairly familiar, then gradually switch to less familiar material.

Automatic Code Machines

The two practice sets which are described in this chapter are of most value when you have someone with whom to practice. Automatic code machines are not recommended to anyone who can possibly obtain a companion with whom to practice, someone who is also interested in learning the code. If you are unable to enlist a code partner and have to practice by yourself, the best way to get receiving practice is by the use of a tape machine (automatic code-sending machine) with several practice tapes. Or you can use a set of phonograph code-practice records. The records are of use only if you have a phonograph whose turntable speed is readily adjustable. The tape machine can be rented by the month for a reasonable fee.

Once you can copy about 10 w.p.m. you can also get receiving practice by listening to slow-sending stations on your receiver. Many amateur stations send slowly particularly when working far distant stations. When receiving conditions are particularly poor many commercial stations also send slowly, sometimes repeating every word. Until you can copy around 10 w.p.m. your receiver isn't much use, and either another operator or a machine or records is necessary for getting receiving practice after you have once memorized the code.

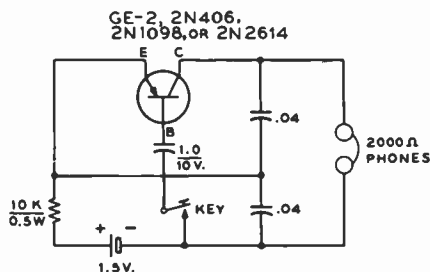

Figure 6

SIMPLE TRANSISTOR CODE PRACTICE OSCILLATOR

An inexpensive entertainment-type PNP germanium transistor requires only a single 1.5-volt flashlight battery for power. The inductance of the phone windings forms part of the oscillator circuit. The pitch of the note may be changed by varying the value of the two capacitors across the earphones.

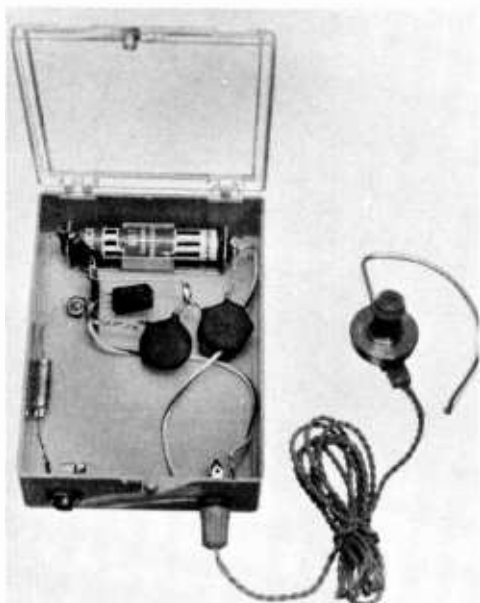

Figure 7

The circuit of Figure 6 is used in this miniature transistorized code practice oscillator. Components are mounted in a small plastic case. The transistor is attached to a three terminal phenolic mounting strip. Sub-miniature jacks are used for the key and phones connections. A hearing aid earphone may also be used, as shown. The phone is stored in the plastic case when not in use.

Code Practice Sets If you don't feel too foolish doing it, you can secure a measure of code practice with the help of a partner by sending "dit-dah" messages to each other while riding to work, eating lunch, etc. It is better, however, to use a buzzer or code-practice oscillator in conjunction with a regular telegraph key.

As a good key may be considered an investment it is wise to make a well-made key your first purchase. Regardless of what type code-practice set you use, you will need a key, and later on you will need one to key your transmitter. If you get a good key to begin with, you won't have to buy another one later.

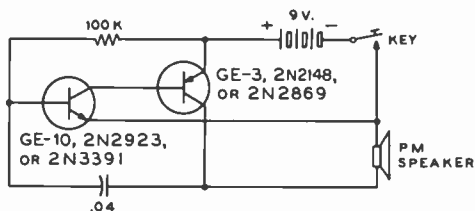

Figure 8

CODE-PRACTICE OSCILLATOR SUITABLE FOR SPEAKER OPERATION.

The key should be rugged and have fairly heavy contacts. Not only will the key stand up better, but such a key will contribute to the "heavy" type of sending so desirable for radio work. Morse (telegraph) operators use a "light" style of sending and can send somewhat faster when using this light touch. But, in radio work static and interference are often present, and a slightly heavier dot is desirable. If you use a husky key, you will find yourself automatically sending in this manner.

To generate a tone simulating a code signal as heard on a receiver, either a mechanical buzzer or an audio oscillator may be used. Figure 5 shows a simple code-practice set using a buzzer which may be used directly simply by mounting the buzzer on a sounding board, or the buzzer may be used to feed from one to four pairs of conventional high-impedance phones.

An example of the audio-oscillator type of code-practice set is illustrated in figures 6 and 7. An inexpensive entertainment-type transistor is used in place of the more expensive, power-consuming vacuum tube. A single "penlite" 1½-volt cell powers the unit. The coils of the earphones form the inductive portion of the resonant circuit. Phones having an impedance of 2000 ohms or higher should be used. Surplus type R-14 earphones also work well with this circuit.

A code-practice oscillator that will drive a loudspeaker to good room volume is shown in figure 8. Inexpensive entertainment-type transistors are used and any size permanent magnet speaker may be used. Mount the speaker on a large sounding board for best volume.

Direct-Current Circuits

All naturally occurring matter (excluding artificially produced radioactive substances) is made up of 92 fundamental constituents called *elements*. These elements can exist either in the free state such as iron, oxygen, carbon, copper, tungsten, and aluminum, or in chemical unions commonly called *compounds*. The smallest unit which still retains all the original characteristics of an element is the *atom*.

Combinations of atoms, or subdivisions of compounds, result in another fundamental unit, the *molecule*. The molecule is the smallest unit of any compound. All reactive elements when in the gaseous state also exist in the molecular form, made up of two or more atoms. The nonreactive gaseous elements helium, neon, argon, krypton, xenon, and radon are the only gaseous elements that ever exist in a stable monatomic state at ordinary temperatures.

2-1 The Atom

An atom is an extremely small unit of matter—there are literally billions of them making up so small a piece of material as a speck of dust. To understand the basic theory of electricity and hence of radio, we must go further and divide the atom into its main components, a positively charged *nucleus* and a cloud of negatively charged particles that surround the nucleus. These particles, swirling around the nucleus in

elliptical orbits at an incredible rate of speed, are called *orbital electrons*.

It is on the behavior of these orbital electrons when freed from the atom, that depends the study of electricity and radio, as well as allied sciences. Actually it is possible to subdivide the nucleus of the atom into a dozen or so different particles, but this further subdivision can be left to quantum mechanics and atomic physics. As far as the study of electronics is concerned it is only necessary for the reader to think of the normal atom as being composed of a nucleus having a net positive charge that is exactly neutralized by the one or more orbital electrons surrounding it.

The atoms of different elements differ in respect to the charge on the positive nucleus and in the number of electrons revolving around this charge. They range all the way from hydrogen, having a net charge of one on the nucleus and one orbital electron, to uranium with a net charge of 92 on the nucleus and 92 orbital electrons. The number of orbital electrons is called the *atomic number* of the element.

Action of the Electrons From the foregoing it must not be thought that the electrons revolve in a haphazard manner around the nucleus. Rather, the electrons in an element having a large atomic number are grouped into rings having a definite number of electrons. The only atoms in which these rings are completely

filled are those of the inert gases mentioned before; all other elements have one or more uncompleted rings of electrons. If the uncompleted ring is nearly empty, the element is *metallic* in character, being most metallic when there is only one electron in the outer ring. If the incomplete ring lacks only one or two electrons, the element is usually *non-metallic*. Elements with a ring about half completed will exhibit both nonmetallic and metallic characteristics; carbon, silicon, germanium, and arsenic are examples. Such elements are called *semiconductors*.

In metallic elements these outer ring electrons are rather loosely held. Consequently, there is a continuous helter-skelter movement of these electrons and a continual shifting from one atom to another. The electrons which move about in a substance are called *free electrons*, and it is the ability of these electrons to drift from atom to atom which makes possible the *electric current*.

Conductors, Semiconductors, and Insulators If the free electrons are numerous and loosely

held, the element is a good *conductor*. On the other hand, if there are few free electrons (as is the case when the electrons in an outer ring are tightly held), the element is a poor conductor. If there are virtually no free electrons, the element is a good *insulator*.

Materials having few free electrons are classed as semiconductors and exhibit conductivity approximately midway between that of good conductors and good insulators.

2-2 Fundamental Electrical Units and Relationships

Electromotive Force: The free electrons in a conductor move constantly about and change their position in a haphazard manner. To produce a drift of electrons, or *electric current*, along a wire it is necessary that there be a difference in "pressure" or *potential* between the two ends of the wire. This *potential difference* can be produced by connecting a source of *electrical potential* to the ends of the wire.

As will be explained later, there is an excess of electrons at the negative terminal of a battery and a deficiency of electrons at the positive terminal, due to chemical action. When the battery is connected to the wire, the deficient atoms at the positive terminal attract free electrons from the wire in order for the positive terminal to become neutral. The attracting of electrons continues through the wire, and finally the excess electrons at the negative terminal of the battery are attracted by the positively charged atoms at the end of the wire. Other sources of electrical potential (in addition to a battery) are: an electrical generator (dynamo), a thermocouple, an electrostatic generator (static machine), a photoelectric cell, and a crystal or piezoelectric generator.

Thus it is seen that a potential difference is the result of a difference in the number of electrons between the two (or more) points in question. The force or pressure due to a potential difference is termed the *electromotive force*, usually abbreviated *e.m.f.* or *E.M.F.* It is expressed in units called *volts* (abbreviated E or V).

It should be noted that for there to be a potential difference between two bodies or points it is not necessary that one have a positive charge and the other a negative charge. If two bodies each have a negative charge, but one more negative than the other, the one with the lesser negative charge will act as though it were positively charged *with respect to the other body*. It is the *algebraic* potential difference that determines the force with which electrons are attracted or repulsed, the potential of the earth being taken as the zero reference point.

The Electric Current The flow of electric charges, either electrons, holes (see Chapter Five), or ions constitutes an *electric current*. The flow may be induced by the application of an electromotive force. This flow, or drift, is in addition to the irregular movements of the electrons. However, it must not be thought that each free electron travels from one end of the circuit to the other. On the contrary, each free electron travels only a short distance before colliding with an atom;

this collision generally knocks off one or more electrons from the atom, which in turn move a short distance and collide with other atoms, knocking off other electrons. Thus, in the general drift of electrons along a wire carrying an electric current, each electron travels only a short distance and the excess of electrons at one end and the deficiency at the other are balanced by the source of the e.m.f. When this source is removed the state of normalcy returns; there is still the rapid interchange of free electrons between atoms, but there is no general trend or "net movement" in either one direction or the other—in other words, no current flows.

Ampere and Coulomb There are two units of measurement associated with current, and they are often confused. The *rate of flow* of electricity is stated in *amperes*. The unit of *quantity* is the *coulomb* (q). A coulomb is equal to 6.28×10^{18} electrons, and when this quantity of electrons flows by a given point in every second, a current of one ampere is said to be flowing. An ampere (I) is equal to one coulomb per second; a coulomb is, conversely, equal to one ampere-second. Thus we see that *coulomb* indicates *amount* and *ampere* indicates *rate of flow* of electric current.

For convenience, two smaller units *milliampere* ($\frac{1}{1000}$ ampere) and *microampere* ($\frac{1}{1,000,000}$) are also used in electronic terminology.

Current and Electron Flow Older textbooks speak of current flow as being from the positive terminal of the e.m.f. source through the conductor to the negative terminal. Nevertheless, it has long been an established fact that the current flow in a metallic conductor is the *electron* drift from the negative terminal of the source of voltage through the conductor to the positive terminal. The only exceptions to the electronic direction of flow occur in gaseous and electrolytic conductors where the flow of positive *ions* toward the cathode, or negative electrode, constitutes a positive flow in the opposite direction to the electron flow. (An ion is an atom, molecule, or particle which either lacks one or more

electrons, or else has an excess of one or more electrons.)

In radio work the terms "electron flow" and "current" are becoming accepted as being synonymous, but the older terminology is still accepted in the electrical (industrial) field. Because of the confusion this sometimes causes, it is often safer to refer to the direction of electron flow rather than to the direction of the "current." Since electron flow consists actually of a passage of *negative* charges, current flow and *algebraic* electron flow do pass in the same direction.

Resistance The flow of current in a material depends on the ease with which electrons can be detached from the atoms of the material and on its molecular structure. In other words, the easier it is to detach electrons from the atoms the more free electrons there will be to contribute to the flow of current, and the fewer collisions that occur between free electrons and atoms the greater will be the total electron flow.

The opposition to a steady electron flow is called the *resistance* (R) of a material, and is one of its physical properties.

The unit of resistance is the *ohm*. Every substance has a *specific resistance*, usually expressed as *ohms per mil-foot*, which is determined by the material's molecular structure and temperature. A mil-foot is a piece of material one circular mil in area and one foot long. Another measure of resistivity frequently used is expressed in the units *microhms per centimeter cube*. The resistance of a uniform length of a given substance is directly proportional to its length and specific resistance, and inversely proportional to its cross-sectional area. A wire with a certain resistance for a given length will have twice as much resistance if the length of the wire is doubled. For a given length, doubling the cross-sectional area of the wire will *halve* the resistance, while doubling the *diameter* will reduce the resistance to *one fourth*. This is true since the cross-sectional area of a wire varies as the square of the diameter. The relationship between the resistance and the linear dimensions of a conductor may be expressed by the following equation:

$$R = \frac{rl}{A}$$

where,

R equals resistance in ohms,
 r equals resistivity in *ohms per mil-foot*,
 l equals length of conductor in feet,
 A equals cross-sectional area in circular
 mils.

For convenience, two larger units the *kilohm* (1000 ohms) and the *megohm* (1,000,000 ohms) are often used.

The resistance also depends on temperature, rising with an increase in temperature for most substances (including most metals), due to increased electron acceleration and hence a greater number of impacts between electrons and atoms. However, in the case of some substances such as carbon and glass the temperature coefficient is negative and the resistance decreases as the temperature increases. This is also true of electrolytes. The temperature may be raised by the external application of heat, or by the flow of the current itself. In the latter case, the temperature is raised by the heat generated when the electrons and atoms collide.

Conductors and Insulators In the molecular structure of many materials such as glass, porcelain, and mica all electrons are tightly held within their orbits and there are comparatively few free electrons. This type of substance will conduct an electric current only with great difficulty and is known as an *insulator*. An insulator is said to have a high electrical *resistance*.

On the other hand, materials that have a large number of free electrons are known as *conductors*. Most metals (those elements which have only one or two electrons in their outer ring) are good conductors. Silver, copper, and aluminum, in that order, are the best of the common metals used as conductors and are said to have the greatest *conductivity*, or lowest resistance to the flow of an electric current.

Fundamental Electrical Units These units are the *volt*, the *ampere*, and the *ohm*. They were mentioned in the preceding paragraphs, but were not completely defined in terms of fixed, known quantities.

TABLE 1. TABLE OF RESISTIVITY

Material	Resistivity in Ohms per Circular Mil-Foot	Temp. Coeff. of resistance per °C. at 20° C.
Aluminum	17	0.0049
Brass	45	0.003 to 0.007
Cadmium	46	0.0038
Chromium	16	0.00
Copper	10.4	0.0039
Iron	59	0.006
Silver	9.8	0.004
Zinc	36	0.0035
Nichrome	650	0.0002
Constantan	295	0.00001
Manganin	290	0.00001
Manel	255	0.0019

The fundamental unit of *current*, or *rate of flow* of electricity is the ampere. A current of one ampere will deposit silver from a specified solution of silver nitrate at a rate of 1.118 milligrams per second.

The international standard for the ohm is the resistance offered by a uniform column of mercury at 0° C., 14.4521 grams in mass, of constant cross-sectional area and 106.300 centimeters in length. The expression *megohm* (1,000,000 ohms) is also sometimes used when speaking of very large values of resistance.

A volt is *the e.m.f. that will produce a current of one ampere through a resistance of one ohm*. The standard of electromotive force is the Weston cell which at 20° C. has a potential of 1.0183 volts across its terminals. This cell is used only for reference purposes in a bridge circuit, since only an infinitesimal amount of current may be drawn from it without disturbing its characteristics.

Ohm's Law The relationship between the electromotive force (voltage), the flow of current (amperes), and the resistance which impedes the flow of current (ohms), is very clearly expressed in a simple but highly valuable law known as *Ohm's Law*. This law states that *the current in amperes is equal to the voltage in volts divided by the resistance in ohms*. Expressed as an equation:

$$I = \frac{E}{R}$$

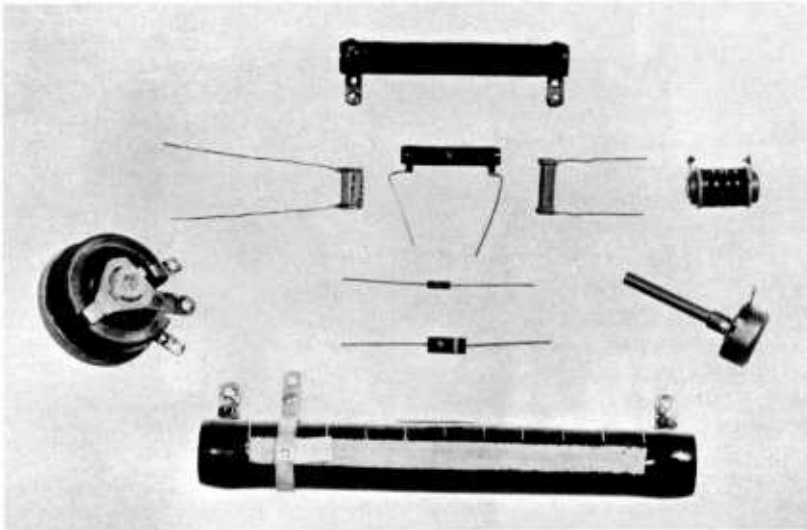

Figure 1
TYPICAL RESISTORS

Shown above are various types of resistors used in electronic circuits. The larger units are power resistors. On the left is a variable power resistor. Three precision-type resistors are shown in the center with two small composition resistors beneath them. At the right is a composition-type potentiometer, used for audio circuitry.

If the voltage (E) and resistance (R) are known, the current (I) can be readily found. If the voltage and current are known, and the resistance is unknown, the resistance (R) is equal to $\frac{E}{I}$. When the

voltage is the unknown quantity, it can be found by multiplying $I \times R$. These three

equations are all secured from the original by simple transposition. The expressions are here repeated for quick reference:

$$I = \frac{E}{R} \quad R = \frac{E}{I} \quad E = IR$$

where,

I is the current in amperes,
 R is the resistance in ohms,
 E is the electromotive force in volts.

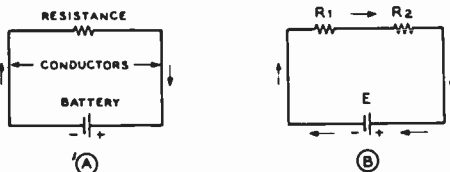
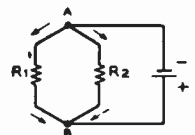

Figure 2

SIMPLE SERIES CIRCUITS

At (A) the battery is in series with a single resistor. At (B) the battery is in series with two resistors, the resistors themselves being in series. The arrows indicate the direction of electron flow.

Figure 3
SIMPLE PARALLEL CIRCUIT



The two resistors R_1 and R_2 are said to be in parallel since the flow of current is offered two parallel paths. An electron leaving point A will pass either through R_1 or R_2 , but not through both, to reach the positive terminal of the battery. If a large number of electrons are considered, the greater number will pass through whichever of the two resistors has the lower resistance.

Figure 4
SERIES-PARALLEL
CIRCUIT

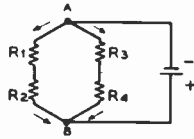

In this type of circuit the resistors are arranged in series groups, and these groups are then placed in parallel.

Conductance Instead of speaking of the resistance of a circuit, the *conductance* may be referred to as a measure of the ease of current flow. Conductance is the reciprocal of resistance and is measured in *mhos* (ohms spelled backwards) and is designated by the letter *G*.

The relation between resistance and conductance is:

$$G = \frac{1}{R}, R = \frac{1}{G} \text{ or } I = EG$$

In electronics work, a small unit of conductance, which is equal to one-millionth of a mho, frequently is used. It is called a *micromho*.

Application of Ohm's Law All electrical circuits fall into one of three classes: *series circuits*, *parallel circuits*, and *series-parallel circuits*. A series circuit is one in which the current flows in a single continuous path and is of the same value at every point in the circuit (figure 2). In a parallel circuit there are two or more current paths between two points in the circuit, as shown in figure 3. Here the current divides at A, part going through R_1 and part through R_2 , and combines at B to return to the battery. Figure 4 shows a series-parallel circuit. There are two paths between points A and B as in the parallel circuit, and in addition there are two resistances in series in each branch of the parallel combination. Two other examples of series-parallel arrangements appear in figure 5. The way in which the current splits to flow through the parallel branches is shown by the arrows.

In every circuit, each of the parts has some resistance: the batteries or generator, the connecting conductors, and the apparatus itself. Thus, if each part has some resistance, no matter how little, and a current is flowing through it, there will be a voltage drop across it. In other words, there will

be a potential difference between the two ends of the circuit element in question. This drop in voltage is equal to the product of the current and the resistance hence it is called the *IR drop*.

Internal Resistance The source of voltage has an *internal* resistance, and when connected into a circuit so that current flows, there will be an *IR* drop in the source just as in every other part of the circuit. Thus, if the terminal voltage of the source could be measured in a way that would cause no current to flow, it would be found to be more than the voltage measured when a current flows by the amount of the *IR* drop in the source. The voltage measured with no current flowing is termed the *no load* voltage; that measured with current flowing is the *load* voltage. It is apparent that a voltage source having a low internal resistance is most desirable.

Resistances in Series The current flowing in a series circuit is equal to the voltage impressed divided by the *total* resistance across which the voltage is impressed. Since the same current flows through every part of the circuit, it is merely necessary to add all the individual resistances to obtain the total resistance. Expressed as a formula:

$$R_{\text{Total}} = R_1 + R_2 + R_3 + \dots + R_N$$

Of course, if the resistances happened to be all the same value, the total resistance would be the resistance of one multiplied by the number of resistors in the circuit.

Resistances in Parallel Consider two resistors, one of 100 ohms and one of 10 ohms, connected in parallel as in figure 3, with a potential of 10 volts applied across each resistor, so the current through each can be easily calculated.

$$I = \frac{E}{R}$$

$$E = 10 \text{ volts} \quad I_1 = \frac{10}{100} = 0.1 \text{ ampere}$$

$$E = 10 \text{ volts} \quad I_2 = \frac{10}{10} = 1.0 \text{ ampere}$$

$$\text{Total current} = I_1 + I_2 = 1.1 \text{ ampere}$$

Until it divides at A, the entire current of 1.1 amperes is flowing through the conductor from the battery to A, and again from B through the conductor to the battery. Since this is more current than flows through the smaller resistor it is evident that the resistance of the parallel combination must be less than 10 ohms, the resistance of the smaller resistor. We can find this value by applying Ohm's Law.

$$R_T = \frac{E}{I}$$

$$E = 10 \text{ volts} \quad I = 1.1 \text{ amperes} \quad R_T = \frac{10}{1.1} = 9.09 \text{ ohms}$$

The resistance of the parallel combination is 9.09 ohms.

Mathematically, we can derive a simple formula for finding the effective resistance of two resistors connected in parallel.

$$R_T = \frac{R_1 \times R_2}{R_1 + R_2}$$

where,

- R_T is the unknown resistance,
- R_1 is the resistance of the first resistor,
- R_2 is the resistance of the second resistor.

If the effective value required is known, and it is desired to connect one unknown resistor in parallel with one of known value, the following transposition of the above formula will simplify the problem of obtaining the unknown value:

$$R_2 = \frac{R_1 \times R_T}{R_1 - R_T}$$

where,

- R_T is the effective value required,
- R_1 is the known resistor,
- R_2 is the value of the unknown resistance necessary to give R_T when in parallel with R_1 .

The resultant value of placing a number of unlike resistors in parallel is equal to the reciprocal of the sum of the reciprocals of the various resistors. This can be expressed as:

$$R_T = \frac{1}{\frac{1}{R_1} + \frac{1}{R_2} + \frac{1}{R_3} + \dots + \frac{1}{R_n}}$$

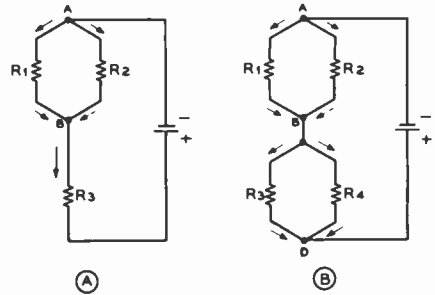

Figure 5

OTHER COMMON SERIES-PARALLEL CIRCUITS

The effective value of placing any number of unlike resistors in parallel can be determined from the above formula. However, it is commonly used only when there are three or more resistors under consideration, since the simplified formula given before is more convenient when only two resistors are being used.

From the above, it also follows that when two or more resistors of the same value are placed in parallel, the effective resistance of the paralleled resistors is equal to the value of one of the resistors divided by the number of resistors in parallel.

The effective value of resistance of two or more resistors connected in parallel is *always* less than the value of the lowest resistance in the combination. It is well to bear this simple rule in mind, as it will assist greatly in approximating the value of paralleled resistors.

Resistors in Series-Parallel To find the total resistance of several resistors connected in series-parallel, it is usually easiest to apply either the formula for series resistors or the parallel resistor formula first, in order to reduce the original arrangement to a simpler one. For instance, in figure 4 the series resistors should be added in each branch, then there will be but two resistors in parallel to be calculated. Similarly in figure 6, although here there will be three parallel resistors after adding the series resistors in each branch. In figure 6B the paralleled resistors should be reduced to the equivalent series value, and then the series resistance value can be added.

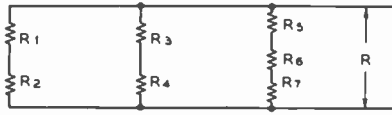

Figure 6

ANOTHER TYPE OF SERIES-PARALLEL CIRCUIT

Resistances in series-parallel can be solved by combining the series and parallel formulas into one similar to the following (refer to figure 6):

$$R_T = \frac{1}{\frac{1}{R_1 + R_2} + \frac{1}{R_3 + R_4} + \frac{1}{R_5 + R_6 + R_7}}$$

Voltage Dividers A *voltage divider* is exactly what its name implies: a resistor or a series of resistors connected across a source of voltage from which various lesser values of voltage may be obtained by connection to various points along the resistor.

A voltage divider serves a most useful purpose in a radio receiver, transmitter or amplifier, because it offers a simple means of obtaining plate, screen, and bias voltages of different values from a common power supply source. It may also be used to obtain very low voltages of the order of .01 to .001 volt with a high degree of accuracy, even though a means of measuring such voltages is lacking. The procedure for making these measurements can best be given in the following example.

Assume that an accurately calibrated voltmeter reading from 0 to 150 volts is available, and that the source of voltage is exactly 100 volts. This 100 volts is then impressed through a resistance of exactly 1000 ohms. It will then be found that the voltage along various points on the resistor, with respect to the grounded end, is exactly proportional to the resistance at that point. From Ohm's Law, the current would be 0.1 ampere; this current remains unchanged since the original value of resistance (1000 ohms) and the voltage source (100 volts) are unchanged. Thus, at a 500-ohm point on the resistor (half its entire resistance), the voltage will likewise be halved or reduced to 50 volts.

The equation ($E = I \times R$) gives the proof: $E = 500 \times 0.1 = 50$. At the point of 250 ohms on the resistor, the voltage will be one-fourth the total value, or 25 volts ($E = 250 \times 0.1 = 25$). Continuing with this process, a point can be found where the resistance measures exactly 1 ohm and where the voltage equals 0.1 volt. It is, therefore, obvious that if the original source of voltage and the resistance can be measured, it is a simple matter to predetermine the voltage at any point along the resistor, provided that the current remains constant, and provided that no current is taken from the tap-on point unless this current is taken into consideration.

Voltage-Divider Calculations Proper design of a voltage divider for any type of radio equipment is a relatively simple matter. The first consideration is the amount of "bleeder current" to be drawn. In addition, it is also necessary that the desired voltage and the exact current at each tap on the voltage divider be known.

Figure 7 illustrates the flow of current in a simple voltage-divider and load circuit. The light arrows indicate the flow of bleeder current, while the heavy arrows indicate the flow of the load current. The design of a combined bleeder resistor and voltage divider, such as is commonly used in radio equipment, is illustrated in the following example:

A power supply delivers 300 volts and is conservatively rated to supply all needed current for the receiver and still allow a bleeder current of 10 milliamperes. The following voltages are wanted: 75 volts at 2 milliamperes for the detector tube, 100

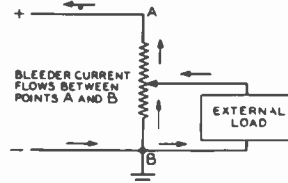

Figure 7

SIMPLE VOLTAGE-DIVIDER CIRCUIT

The arrows indicate the manner in which the current flow divides between the voltage divider itself and the external load circuit.

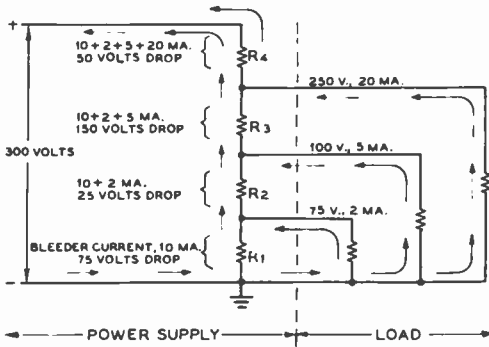

Figure 8

MORE COMPLEX VOLTAGE DIVIDER

The method for computing the values of the resistors is discussed in the accompanying text.

volts at 5 milliamperes for the screens of the tubes, and 250 volts at 20 milliamperes for the plates of the tubes. The required voltage drop across R_1 is 75 volts, across R_2 25 volts, across R_3 150 volts, and across R_4 it is 50 volts. These values are shown in the diagram of figure 8. The respective current values are also indicated. Apply Ohm's Law:

$$R_1 = \frac{E}{I} = \frac{75}{.01} = 7500 \text{ ohms}$$

$$R_2 = \frac{E}{I} = \frac{25}{.012} = 2083 \text{ ohms}$$

$$R_3 = \frac{E}{I} = \frac{150}{.017} = 8823 \text{ ohms}$$

$$R_4 = \frac{E}{I} = \frac{50}{.037} = 1351 \text{ ohms}$$

$$R_{\text{Total}} = 7500 + 2083 + 8823 + 1351 = 19,757 \text{ ohms}$$

A 20,000-ohm resistor with three sliding taps will be the approximately correct size, and would ordinarily be used because of the difficulty in securing four separate resistors of the exact odd values indicated, and because no adjustment would be possible to compensate for any slight error in estimating the probable currents through the various taps.

When the sliders on the resistor once are set to the proper point, as in the above ex-

ample, the voltages will remain constant at the values shown as long as the current remains a constant value.

Disadvantages of Voltage Dividers One of the serious disadvantages of the voltage divider becomes evident when the current drawn from one of the taps changes. It is obvious that the voltage drops are interdependent and, in turn, the individual drops are in proportion to the current which flows through the respective sections of the divider resistor. The only remedy lies in providing a heavy steady bleeder current in order to make the individual currents so small a part of the total current that any change in current will result in only a slight change in voltage. This can seldom be realized in practice because of the excessive values of bleeder current which would be required.

Kirchhoff's Laws Ohm's Law is all that is necessary to calculate the values in simple circuits, such as the preceding examples; but in more complex problems, involving several loops, or more than one voltage in the same closed circuit, the use of *Kirchhoff's laws* will greatly simplify the calculations. These laws are merely rules for applying Ohm's Law.

Kirchhoff's first law is concerned with net current to a point in a circuit and states that:

At any point in a circuit the current flowing toward the point is equal to the current flowing away from the point.

Stated in another way: if currents flowing to the point are considered positive, and those flowing from the point are considered negative, the sum of all currents flowing toward and away from the point — taking signs into account — is equal to zero. Such a sum is known as an *algebraic sum*; such that the law can be stated thus: *The algebraic sum of all currents entering and leaving a point is zero.*

Figure 9 illustrates this first law. If the effective resistance of the network of resistors is 5 ohms, it can be seen that 4 amperes flow toward point A, and 2 amperes flow away through the two 5-ohm resistors

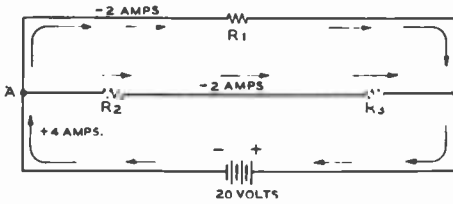

Figure 9

ILLUSTRATING KIRCHHOFF'S FIRST LAW

The current flowing toward point "A" is equal to the current flowing away from point "A."

in series. The remaining 2 amperes flow away through the 10-ohm resistor. Thus, there are 4 amperes flowing to point A and 4 amperes flowing away from the point. If R_T is the effective resistance of the network (5 ohms), $R_1 = 10$ ohms, $R_2 = 5$ ohms, $R_3 = 5$ ohms, and $E = 20$ volts, we can set up the following equation:

$$\frac{E}{R_T} - \frac{E}{R_1} - \frac{E}{R_2 + R_3} = 0$$

$$\frac{20}{5} - \frac{20}{10} - \frac{20}{5 + 5} = 0$$

$$4 - 2 - 2 = 0$$

Kirchhoff's second law is concerned with net voltage drop around a closed loop in a circuit and states that:

In any closed path or loop in a circuit the sum of the IR drops must equal the sum of the applied e.m.f.'s.

The second law also may be conveniently stated in terms of an algebraic sum as: *The algebraic sum of all voltage drops around a closed path or loop in a circuit is zero.* The applied e.m.f.'s (voltages) are considered positive, while IR drops taken in the direction of current flow (including the internal drop of the sources of voltage) are considered negative.

Figure 10 shows an example of the application of Kirchhoff's laws to a comparatively simple circuit consisting of three resistors and two batteries. First assume an arbitrary direction of current flow in each closed loop of the circuit, drawing an arrow to indicate the assumed direction of current flow. Then equate the sum of all IR drops plus battery

drops around each loop to zero. You will need one equation for each unknown to be determined. Then solve the equations for the unknown currents in the general manner indicated in figure 10. If the answer comes out positive the direction of current flow you originally assumed was correct. If the answer comes out negative, the current flow is in the opposite direction to the arrow which was drawn originally. This is illustrated in the example of figure 10, where the direction of flow of I_1 is opposite to the direction assumed in the sketch.

Power in Resistive Circuits In order to cause electrons to flow through a conductor, constituting a current flow, it is necessary to apply an electromotive force (voltage) across the circuit. Less power is expended in creating a small current flow through a given resistance than in creating a large one; so it is necessary to have a unit of power as a reference.

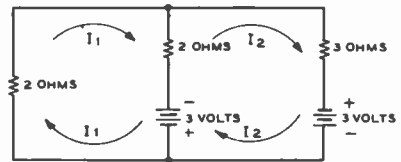

1. SET VOLTAGE DROPS AROUND EACH LOOP EQUAL TO ZERO.
 $I_1(2\text{ OHMS}) + 2(1 - I_2) + 3 = 0$ (FIRST LOOP)
 $-6 + 2(I_2 - I_1) + 3I_2 = 0$ (SECOND LOOP)
2. SIMPLIFY
 $2I_1 + 2I_2 - 2I_2 + 3 = 0$ $2I_2 - 2I_1 + 3I_2 - 6 = 0$
 $\frac{4I_1 + 3}{2} = I_2$ $\frac{5I_2 - 2I_1 - 6}{5} = 0$
3. EQUATE
 $\frac{4I_1 + 3}{2} = \frac{2I_1 + 6}{5}$
4. SIMPLIFY
 $20I_1 + 15 = 4I_1 + 12$
 $I_1 = -\frac{3}{16}$ AMPERE
5. RE-SUBSTITUTE
 $I_2 = \frac{-\frac{3}{16} + 3}{2} = \frac{2\frac{1}{2}}{2} = 1\frac{1}{8}$ AMPERE

Figure 10

ILLUSTRATING KIRCHHOFF'S SECOND LAW

The voltage drop around any closed loop in a network is equal to zero.



Figure 11

MATCHING OF RESISTANCES

To deliver the greatest amount of power to the load, the load resistance R_L should be equal to the internal resistance of the battery R_r .

The unit of electrical power is the *watt*, which is the rate of energy consumption when an e.m.f. of 1 volt forces a current of 1 ampere through a circuit. The power in a resistive circuit is equal to the product of the voltage applied across, and the current flowing in, a given circuit. Hence: P (watts) = E (volts) $\times I$ (amperes).

Since it is often convenient to express power in terms of the resistance of the circuit and the current flowing through it, a substitution of IR for E ($E = IR$) in the above formula gives: $P = IR \times I$ or $P = I^2R$. In terms of voltage and resistance, $P = E^2/R$. Here, $I = E/R$ and when this is substituted for I the original formula becomes $P = E \times E/R$, or $P = E^2/R$. To repeat these three expressions:

$$P = EI, P = I^2R, \text{ and } P = E^2/R$$

where,

P is the power in watts,
 E is the electromotive force in volts, and
 I is the current in amperes.

To apply the above equations to a typical problem: The voltage drop across a cathode resistor in a power amplifier stage is 50 volts; the plate current flowing through the resistor is 150 milliamperes. The number of watts the resistor will be required to dissipate is found from the formula: $P = EI$, or $50 \times .150 = 7.5$ watts (.150 ampere is equal to 150 milliamperes). From the foregoing it is seen that a 7.5-watt resistor will safely carry the required current, yet a 10- or 20-watt resistor would ordinarily be used to provide a safety factor.

In another problem, the conditions being similar to those above, but with the resist-

ance ($R = 333\frac{1}{3}$ ohms), and current being the *known* factors, the solution is obtained as follows: $P = I^2R = .0225 \times 333.33 = 7.5$. If only the voltage and resistance are known, $P = E^2/R = 2500/333.33 = 7.5$ watts. It is seen that all three equations give the same results; the selection of the particular equation depends only on the known factors.

Power, Energy and Work It is important to remember that power (expressed in watts, horsepower, etc.), represents the *rate* of energy consumption or the *rate* of doing work. But when we pay our electric bill to the power company we have purchased a specific *amount* of energy or *work* expressed in the common units of *kilowatt-hours*. Thus *rate* of energy consumption (watts or kilowatts) multiplied by *time* (seconds, minutes, or hours) gives us total energy or work. Other units of energy are the watt-second, BTU, calorie, erg, and joule.

Heating Effect Heat is generated when a source of voltage causes a current to flow through a resistor (or, for that matter, through any conductor). As explained earlier, this is due to the fact that heat is given off when free electrons collide with the atoms of the material. More heat is generated in high-resistance materials than in those of low resistance, since the free electrons must strike the atoms harder to knock off other electrons. As the heating effect is a function of the current flowing and the resistance of the circuit, the power expended in heat is given by the second formula: $P = I^2R$.

2-3 Electrostatics and Capacitors

Electrical energy can be stored in an *electrostatic field*. A device capable of storing energy in such a field is called a *capacitor* (in earlier usage the term *condenser* was frequently used but the IEEE standards call for the use of capacitor instead of condenser) and is said to have a certain *capacitance*. The *energy* stored in an electrostatic field is expressed in *joules* (watt-seconds) and is equal to $CE^2/2$, where C is the capacitance

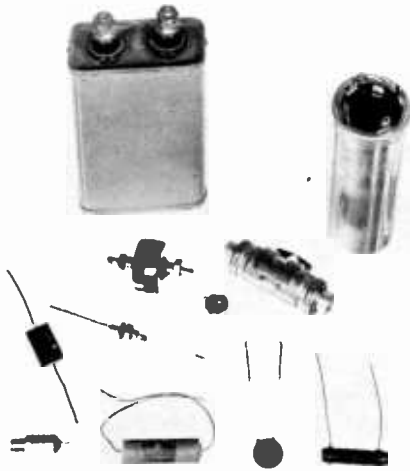

Figure 12

TYPICAL CAPACITORS

The two large units are high value filter capacitors. Shown beneath these are various types of by-pass capacitors for r-f and audio application.

in farads (a unit of capacitance to be discussed) and E is the potential in volts. The charge is equal to CE , the charge being expressed in coulombs.

Capacitance and Capacitors Two metallic plates separated from each other by a thin layer of insulating material (called a *dielectric*, in this case) becomes a *capacitor*. When a source of d-c potential is momentarily applied across these plates, they may be said to become charged. If the same two plates are then joined together momentarily by means of a switch, the capacitor will *discharge*.

When the potential was first applied, electrons immediately flowed from one plate to the other through the battery or such source of d-c potential as was applied to the capacitor plates. However, the circuit from plate to plate in the capacitor was *incomplete* (the two plates being separated by an insulator) and thus the electron flow ceased, meanwhile establishing a shortage of electrons on one plate and a surplus of electrons on the other.

Remember that when a deficiency of electrons exists at one end of a conductor, there

is always a tendency for the electrons to move about in such a manner as to re-establish a state of balance. In the case of the capacitor herein discussed, the surplus quantity of electrons on one of the capacitor plates cannot move to the other plate because the circuit has been broken; that is, the battery or d-c potential was removed. This leaves the capacitor in a *charged* condition; the capacitor plate with the electron deficiency is *positively* charged, the other plate being *negative*.

In this condition, a considerable stress exists in the insulating material (dielectric) which separates the two capacitor plates, due to the mutual attraction of two unlike potentials on the plates. This stress is known as *electrostatic* energy, as contrasted with *electromagnetic* energy in the case of an inductor. This charge can also be called *potential energy* because it is capable of performing work when the charge is released through an external circuit. The charge is proportional to the voltage but the energy is proportional to the voltage squared, as shown in the following analogy.

The charge represents a definite amount of electricity, or a given number of electrons. The potential energy possessed by these electrons depends not only on their number, but also on their potential or voltage.

Compare the electrons to water, and two capacitors to standpipes, a 1- μ fd capacitor to a standpipe having a cross section of 1 square inch and a 2- μ fd capacitor to a

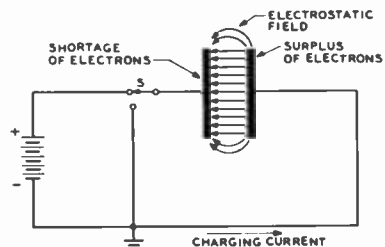

Figure 13

SIMPLE CAPACITOR

Illustrating the imaginary lines of force representing the paths along which the repelling force of the electrons would act on a free electron located between the two capacitor plates.

standpipe having a cross section of 2 square inches. The charge will represent a given volume of water, as the "charge" simply indicates a certain number of electrons. Suppose the quantity of water is equal to 5 gallons.

Now the potential energy, or capacity for doing work, of the 5 gallons of water will be twice as great when confined to the 1 sq. in. standpipe as when confined to the 2 sq. in. standpipe. Yet the volume of water or "charge" is the same in either case.

Likewise a 1- μ fd capacitor charged to 1000 volts possesses twice as much potential energy as does a 2- μ fd capacitor charged to 500 volts, though the *charge* (expressed in *coulombs*: $Q = CE$) is the same in either case.

The Unit of Capacitance: The Farad If the external circuit of the two capacitor plates is completed by joining the terminals together with a piece of wire, the electrons will rush immediately from one plate to the other through the external circuit and establish a state of equilibrium.

This latter phenomenon explains the *discharge* of a capacitor. The amount of stored energy in a charged capacitor is dependent on the charging potential, as well as a factor which takes into account the *size* of the plates, *dielectric thickness*, *nature* of the dielectric, and the *number* of plates. This factor, which is determined by the foregoing, is called the *capacitance* of a capacitor and is expressed in *farads*.

The farad is such a large unit of capacitance that it is rarely used in radio calculations, and the following more practical units have, therefore, been chosen.

$$1 \text{ microfarad} = 1/1,000,000 \text{ farad, or } .000001 \text{ farad, or } 10^{-6} \text{ farad.}$$

$$1 \text{ micromicrofarad or picofarad} = 1/1,000,000 \text{ microfarad, or } .000001 \text{ microfarad, or } 10^{-6} \text{ microfarad.}$$

$$1 \text{ micromicrofarad or picofarad} = \text{one-millionth of one-millionth of a farad, or } 10^{-12} \text{ farad.}$$

If the capacitance is to be expressed in *microfarads* in the equation given for *energy storage*, the factor *C* would then have to be divided by 1,000,000, thus:

$$\text{Stored energy in joules} = \frac{C \times E^2}{2 \times 1,000,000}$$

This storage of energy in a capacitor is one of its very important properties, particularly in those capacitors which are used in power-supply filter circuits.

Dielectric Materials Although any substance which has the characteristics of a good insulator may be used as a dielectric material, commercially manufactured capacitors make use of dielectric materials which have been selected because their characteristics are particularly suited to the job at hand. Air is a very good dielectric material, but an air-spaced capacitor does not have a high capacitance since the dielectric constant of air is only slightly greater than one. A group of other commonly used dielectric materials is listed in Table 2.

Certain materials, such as *bakelite*, *lucite*, and other plastics dissipate considerable energy when used as capacitor dielectrics. This energy loss is expressed in terms of the *power factor* of the capacitor, which repre-

TABLE 2. TABLE OF DIELECTRIC MATERIALS

Material	Dielectric Constant 10 MHz	Power Factor 10 MHz	Softening Point Fahrenheit
Aniline-Formaldehyde Resin	3.4	0.004	260°
Barium Titanate	1200	1.0	—
Castor Oil	4.67		
Cellulose Acetate	3.7	0.04	180°
Glass, Window	6-8	Poor	2000°
Glass, Pyrex	4.5	0.02	
Kel-F Fluorothene	2.5	0.6	—
Methyl-Methacrylate-Lucite	2.6	0.007	160°
Mica	5.4	0.0003	
Mycalex Mykroy	7.0	0.002	650°
Phenol-Formaldehyde, Low-Loss Yellow	5.0	0.015	270°
Phenol-Formaldehyde Black Bakelite	5.5	0.03	350°
Porcelain	7.0	0.005	2800°
Polyethylene	2.25	0.0003	220°
Polystyrene	2.55	0.0002	175°
Quartz, Fused	4.2	0.0002	2600°
Rubber Hard-Ebonite	2.8	0.007	150°
Sealite	6.1	0.003	2700°
Sulfur	3.8	0.003	236°
Teflon	2.1	.0006	—
Titanium Dioxide	100-175	0.0006	2700°
Transformer Oil	2.2	0.003	
Urea-Formaldehyde	5.0	0.05	260°
Vinyl Resins	4.0	0.02	200°
Wood, Maple	4.4	Poor	

sents the portion of the input volt-amperes lost in the dielectric material. Other materials including air, polystyrene and quartz have a very low power factor.

The new *ceramic* dielectrics such as *steatite* (talc) and titanium dioxide products are especially suited for high-frequency and high-temperature operation. Ceramics based on titanium dioxide have an unusually high dielectric constant combined with a low power factor. The temperature coefficient with respect to capacitance of units made with this material depends on the mixture of oxides, and coefficients ranging from zero to over -700 parts per million per degree Centigrade may be obtained in commercial production.

Mycalex is a composition of minute mica particles and lead-borate glass, mixed and fired at a relatively low temperature. It is hard and brittle, but can be drilled or machined when water is used as the cutting lubricant.

Mica dielectric capacitors have a very low power factor and extremely high voltage breakdown per unit of thickness. A mica and copperfoil "sandwich" is formed under pressure to obtain the desired capacity value. The effect of temperature on the pressures in the "sandwich" causes the capacitance of the usual mica capacitor to have large, non-cyclic variations. If the copper electrodes are plated directly on the mica sheets, the temperature coefficient can be stabilized at about 20 parts per million per degree Centigrade. A process of this type is used in the manufacture of "silver mica" capacitors.

Paper dielectric capacitors consist of strips of aluminum foil insulated from each other by a thin layer of paper, the whole assembly being wrapped in a circular bundle. The cost of such a capacitor is low, the capacitance is high in proportion to the size and weight, and the power factor is good. The life of such a capacitor is dependent on the moisture penetration of the paper dielectric, and on the level of the applied d-c voltage.

Air-dielectric capacitors are used in transmitting and receiving circuits, principally where a variable capacitor of high resetability is required. The dielectric strength is high, though somewhat less at radio frequencies than at 60 Hz. In addition, corona discharge at high frequencies will

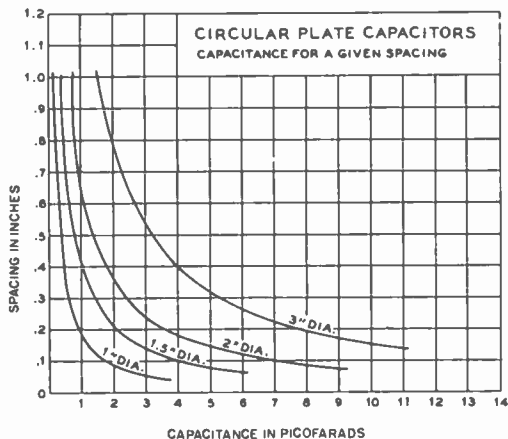

Figure 14

Through the use of this chart it is possible to determine the required plate diameter (with the necessary spacing established by peak voltage considerations) for a circular-plate neutralizing capacitor. The capacitance given is for a dielectric of air and the spacing given is between adjacent faces of the two plates.

cause ionization of the air dielectric causing an increase in power loss. Dielectric strength may be increased by increasing the air pressure, as is done in hermetically sealed radar units. In some units, dry nitrogen gas may be used in place of air to provide a higher dielectric strength than that of air.

Likewise, the dielectric strength of an "air" capacitor may be increased by placing the unit in a vacuum chamber to prevent ionization of the dielectric.

The temperature coefficient of a variable air-dielectric capacitor varies widely and is often noncyclic. Such things as differential expansion of various parts of the capacitor, changes in internal stresses, and different temperature coefficients of various parts contribute to these variances.

Dielectric Constant The capacitance of a capacitor is determined by the thickness and nature of the dielectric material between plates. Certain materials offer a greater capacitance than others, depending on their physical makeup and chemical constitution. This property is expressed by a constant K , called the *dielectric constant*. ($K = 1$ for air.)

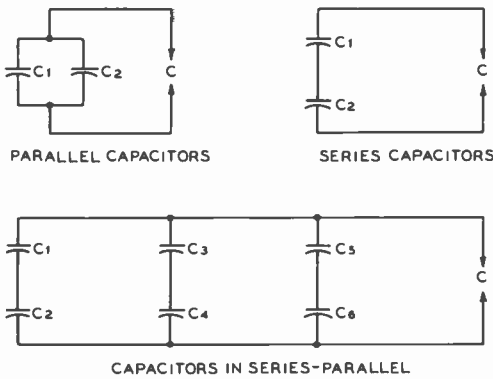

Figure 15

CAPACITORS IN SERIES, PARALLEL, AND SERIES-PARALLEL

Dielectric Breakdown If the charge becomes too great for a given thickness of a certain dielectric, the capacitor will break down, i.e., the dielectric will puncture. It is for this reason that capacitors are rated in the manner of the amount of voltage they will safely withstand as well as the capacitance in microfarads. This rating is commonly expressed as the *d-c working voltage (DCWV)*.

Calculation of Capacitance The capacitance of two parallel plates may be determined with good accuracy by the following formula:

$$C = 0.2248 \times K \times \frac{A}{t}$$

where,

- C equals capacitance in picofarads,
- K equals dielectric constant of spacing material,
- A equals area of dielectric in square inches,
- t equals thickness of dielectric in inches.

This formula indicates that the capacitance is *directly* proportional to the area of the plates and *inversely* proportional to the thickness of the dielectric (spacing between the plates). This simply means that when the area of the plate is doubled, the spacing between plates remaining constant, the capacitance will be doubled. Also, if the area

of the plates remains constant, and the plate spacing is doubled the capacitance will be reduced to half.

The above equation also shows that capacitance is directly proportional to the dielectric constant of the spacing material. An air-spaced capacitor that has a capacitance of 100 pf in air would have a capacitance of 467 pf when immersed in castor oil, because the dielectric constant of castor oil is 4.67 times as great as the dielectric constant of air.

Where the area of the plate is definitely set, when it is desired to know the spacing needed to secure a required capacitance,

$$t = \frac{A \times 0.2248 \times K}{C}$$

where all units are expressed just as in the preceding formula. This formula is not confined to capacitors having only square or rectangular plates, but also applies when the plates are circular in shape. The only change will be the calculation of the *area* of such circular plates; this area can be computed by squaring the *radius* of the plate, then multiplying by 3.1416, or "pi." Expressed as an equation:

$$A = 3.1416 \times r^2$$

where,

r equals radius in inches.

The capacitance of a multiplate capacitor can be calculated by taking the capacitance of one section and multiplying this by the number of dielectric spaces. In such cases, however, the formula gives no consideration to the effects of edge capacitance; so the capacitance as calculated will not be entirely accurate. These additional capacitances will be but a small part of the effective total capacitance, particularly when the plates are reasonably large and thin, and the final result will, therefore, be within practical limits of accuracy.

Capacitors in Parallel and in Series Equations for calculating capacitances of capacitors in *parallel* connections are the same as those for resistors in *series*.

$$C_T = C_1 + C_2 + \dots + C_n$$

Capacitors in *series* connection are calculated in the same manner as are resistors in *parallel* connection.

The formulas are repeated: (1) For two or more capacitors of *unequal* capacitance in series:

$$C_T = \frac{1}{\frac{1}{C_1} + \frac{1}{C_2} + \frac{1}{C_3}}$$

or,
$$\frac{1}{C_T} = \frac{1}{C_1} + \frac{1}{C_2} + \frac{1}{C_3}$$

(2) *Two* capacitors of *unequal* capacitance in series:

$$C_T = \frac{C_1 \times C_2}{C_1 + C_2}$$

(3) Three capacitors of *equal* capacitance in series:

$$C_T = \frac{C_1}{3}$$

where,

C_1 is the common capacitance.

(4) Three or more capacitors of *equal* capacitance in series.

$$C_T = \frac{\text{Value of common capacitance}}{\text{Number of capacitors in series}}$$

(5) Six capacitors in series-parallel:

$$C_T = \frac{1}{\frac{1}{C_1} + \frac{1}{C_2}} + \frac{1}{\frac{1}{C_3} + \frac{1}{C_4}} + \frac{1}{\frac{1}{C_5} + \frac{1}{C_6}}$$

Capacitors in A-C and D-C Circuits When a capacitor is connected into a direct-current circuit, it will block the d.c., or stop the flow of current. Beyond the initial movement of electrons during the period when the capacitor is being charged, there will be no flow of current because the circuit is effectively broken by the dielectric of the capacitor.

Strictly speaking, a very small current may actually flow because the dielectric of the capacitor may not be a perfect insulator. This minute current flow is the leakage current previously referred to and is dependent on the internal d-c resistance of the capaci-

tor. This leakage current is usually quite noticeable in most types of electrolytic capacitors.

When an alternating current is applied to a capacitor, the capacitor will charge and discharge a certain number of times per second in accordance with the frequency of the alternating voltage. The electron flow in the charge and discharge of a capacitor when an a-c potential is applied constitutes an alternating current, in effect. It is for this reason that a capacitor will pass an alternating current yet offer practically infinite opposition to a direct current. These two properties are repeatedly in evidence in a radio circuit.

Voltage Rating of Capacitors in Series Any good paper-dielectric filter capacitor has such a high internal resistance (indicating a good dielectric)

that the exact resistance will vary considerably from capacitor to capacitor even though they are made by the same manufacturer and are of the same rating. Thus, when 1000 volts d. c. are connected across two 1- μ fd 500-volt capacitors in series, the chances are that the voltage will divide unevenly; one capacitor will receive more than 500 volts and the other less than 500 volts.

Voltage Equalizing Resistors By connecting a half-megohm 1-watt carbon resistor across each capacitor,

the voltage will be equalized because the resistors act as a voltage divider, and the internal resistances of the capacitors are so much higher (many megohms) that they have but little effect in disturbing the voltage divider balance.

Carbon resistors of the inexpensive type are not particularly accurate (not being designed for precision service); therefore it is advisable to check several on an accurate ohmmeter to find two that are as close as possible in resistance. The exact resistance is unimportant, just so it is the same for the two resistors used.

Capacitors in Series on A.C. When two capacitors are connected in series, *alternating* voltage pays no heed to the relatively high internal resistance of each

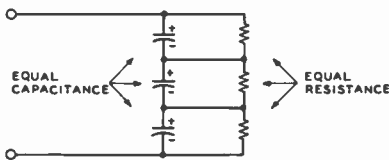

Figure 16

SHOWING THE USE OF VOLTAGE EQUALIZING RESISTORS ACROSS CAPACITORS CONNECTED IN SERIES

capacitor, but divides across the capacitors in inverse proportion to the *capacitance*. Because, in addition to the d-c voltage across a capacitor in a filter or audio amplifier circuit there is usually an a-c or a-f voltage component, it is inadvisable to series-connect capacitors of unequal capacitance even if dividers are provided to keep the d-c voltages within the ratings of the individual capacitors.

For instance, if a 500-volt 1- μ fd capacitor is used in series with a 4- μ fd 500-volt capacitor across a 250-volt a-c supply, the 1- μ fd capacitor will have 200 a-c volts across it and the 4- μ fd capacitor only 50 volts. An equalizing divider, to do any good in this case, would have to be of very low resistance because of the comparatively low impedance of the capacitors to alternating current. Such a divider would draw excessive current and be impracticable.

The safest rule to follow is to use only capacitors of the same capacitance and voltage rating and to install matched high-resistance proportioning resistors across the various capacitors to equalize the d-c voltage drop across each capacitor. This holds regardless of how many capacitors are series-connected.

Electrolytic Capacitors *Electrolytic capacitors* use a very thin film of oxide as the dielectric, and are polarized; that is, they have a positive and a negative terminal which must be properly connected in a circuit; otherwise, the oxide will break down and the capacitor will overheat. The unit then will no longer be of service. When electrolytic capacitors are connected in series, the positive terminal is always connected to the positive lead of the power supply;

the negative terminal of the capacitor connects to the *positive* terminal of the *next* capacitor in the series combination. The method of connection for electrolytic capacitors in series is shown in figure 16. Electrolytic capacitors have very low cost per microfarad of capacitance, but also have a large power factor and high leakage; both dependent on applied voltage, temperature, and the age of the capacitor. The modern electrolytic capacitor uses a dry paste electrolyte embedded in a gauze or paper dielectric. Aluminum foil and the dielectric are wrapped in a circular bundle and are mounted in a cardboard or metal box. Etched electrodes may be employed to increase the effective anode area, and the total capacitance of the unit.

The capacitance of an electrolytic capacitor is affected by the applied voltage, the usage of the capacitor, the temperature and the humidity of the environment. The capacitance usually drops with the aging of the unit. The leakage current and power factor increase with age. At high frequencies the power factor becomes so poor that the electrolytic capacitor acts as a series resistance rather than as a capacitance.

2-4 Magnetism and Electromagnetism

The common bar or horseshoe magnet is familiar to most people. The magnetic field which surrounds it causes the magnet to attract other magnetic materials, such as iron nails or tacks. Exactly the same kind of magnetic field is set up around any conductor carrying a current, but the field exists only while the current is flowing.

Magnetic Fields Before a potential, or voltage, is applied to a conductor there is no external field, because there is no general movement of the electrons in one direction. However, the electrons do progressively move along the conductor when an e.m.f. is applied, the direction of motion depending on the polarity of the e.m.f. Since each electron has an electric field about it, the flow of electrons causes these fields to build up into a resultant external field which acts in a plane at right angles to the direction in which the cur-

rent is flowing. This field is known as the *magnetic field*.

The magnetic field around a current-carrying conductor is illustrated in figure 17. The direction of this magnetic field depends entirely on the direction of electron drift or current flow in the conductor. When the flow is toward the observer, the field about the conductor is clockwise; when the flow is away from the observer, the field is counterclockwise. This is easily remembered if the left hand is clenched, with the thumb outstretched and pointing in the direction of electron flow. The fingers then indicate the direction of the magnetic field around the conductor.

Each electron adds its field to the total external magnetic field, so that the greater the number of electrons moving along the conductor, the stronger will be the resulting field.

One of the fundamental laws of magnetism is that *like poles repel one another and unlike poles attract one another*. This is true of current-carrying conductors as well as of permanent magnets. Thus, if two conductors are placed side by side and the current in each is flowing in the same direction, the magnetic fields will also be in the same direction and will combine to form a larger and stronger field. If the current flow in adjacent conductors is in opposite directions, the magnetic fields oppose each other and tend to cancel.

The magnetic field around a conductor may be considerably increased in strength by winding the wire into a coil. The field around each wire then combines with those of the adjacent turns to form a total field

through the coil which is concentrated along the axis of the coil and behaves externally in a way similar to the field of a bar magnet.

If the left hand is held so that the thumb is outstretched and parallel to the axis of a coil, with the fingers curled to indicate the direction of electron flow around the turns of the coil, the thumb then points in the direction of the north pole of the magnetic field:

The Magnetic Circuit In the magnetic circuit, the units which correspond to current, voltage, and resistance in the electrical circuit are *flux*, *magnetomotive force*, and *reluctance*.

Flux; Flux Density As a current is made up of a drift of electrons, so is a magnetic field made up of lines of force, and the total number of lines of force in a given magnetic circuit is termed the *flux*. The flux depends on the material, cross section, and length of the magnetic circuit, and it varies directly as the current flowing in the circuit. The unit of flux is the *maxwell*, and the symbol is the Greek letter ϕ (phi).

Flux density is the number of lines of force per unit area. It is expressed in *gauss* if the unit of area is the square centimeter (1 gauss = 1 line of force per square centimeter), or in *lines per square inch*. The symbol for flux density is *B* if it is expressed in gauss, or *B* if expressed in lines per sq. in.

Magnetomotive Force The force which produces a flux in a magnetic circuit is called *magnetomotive force*. It is abbreviated m.m.f. and is designated by the letter *F*. The unit of magnetomotive force is the *gilbert*, which is equivalent to $1.26 \times NI$, where *N* is the number of turns and *I* is the current flowing in the circuit in amperes.

The m.m.f. necessary to produce a given flux density is stated in gilberts per centimeter (oersteds) (*H*), or in ampere-turns per inch (*H*).

Reluctance Magnetic reluctance corresponds to electrical resistance, and is the property of a material that opposes the creation of a magnetic flux in the material.

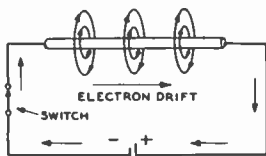

Figure 17

LEFT-HAND RULE

Showing the direction of the magnetic lines of force produced around a conductor carrying an electric current.

It is expressed in *rels*, and the symbol is the letter *R*. A material has a reluctance of 1 rel when an m.m.f. of 1 ampere-turn (*NI*) generates a flux of 1 line of force in it. Combinations of reluctances are treated the same as resistances in finding the total effective reluctance. The *specific reluctance* of any substance is its reluctance per unit volume.

Except for iron and its alloys, most common materials have a specific reluctance very nearly the same as that of a vacuum, which, for all practical purposes, may be considered the same as the specific reluctance of air.

Ohm's Law for Magnetic Circuits The relations between flux, magnetomotive force, and reluctance are exactly the same as the relations between current, voltage, and resistance in the electrical circuit. These can be stated as follows:

$$\phi = \frac{F}{R} \quad R = \frac{F}{\phi} \quad F = \phi R$$

where,

ϕ equals flux, F equals m.m.f.,
 R equals reluctance.

Permeability *Permeability* expresses the ease with which a magnetic field may be set up in a material as compared with the effort required in the case of air. Iron, for example, has a permeability of around 2000 times that of air, which means that a given amount of magnetizing effort produced in an iron core by a current flowing through a coil of wire will produce 2000 times the flux density that the same magnetizing effect would produce in air. It may be expressed by the ratio B/H or B/H . In other words,

$$\mu = \frac{B}{H} \quad \text{or} \quad \mu = \frac{B}{H}$$

where μ is the permeability, B is the flux density in gauss, B is the flux density in lines per square inch, H is the m.m.f. in gilberts per centimeter (oersteds), and H is the m.m.f. in ampere-turns per inch.

These relations may also be stated as follows:

$$H = \frac{B}{\mu} \quad \text{or} \quad H = \frac{B}{\mu}, \quad \text{and} \quad B = H\mu \quad \text{or} \quad B = H\mu$$

It can be seen from the foregoing that permeability is inversely proportional to the specific reluctance of a material.

Saturation Permeability is similar to *electric conductivity*. This is, however, one important difference: the permeability of magnetic materials is not independent of the magnetic current (flux) flowing through it, although electrical conductivity is substantially independent of the electric current in a wire. When the flux density of a magnetic conductor has been increased to the *saturation point*, a further increase in the magnetizing force will not produce a corresponding increase in flux density.

B-H Curve To simplify magnetic circuit calculations, a magnetization curve may be drawn for a given unit of material. Such a curve is termed a B-H curve, and may be determined by experiment. When the current in an iron-core coil is first applied, the relation between the winding current and the core flux is shown at A-B in figure 18. If the current is then reduced to zero, reversed, brought back again to zero and reversed to the original direction, the flux passes through a typical hysteresis loop as shown.

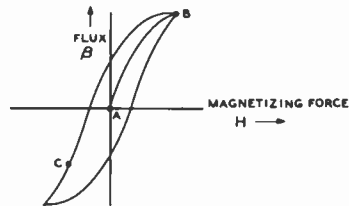

Figure 18

**TYPICAL HYSTERESIS LOOP
 (B-H CURVE = A-B)**

Showing relationship between the current in the winding of an iron-core inductor and the core flux. A direct current flowing through the inductance brings the magnetic state of the core to some point on the hysteresis loop, such as C.

Residual Magnetism; Retentivity The magnetism remaining in a material after the magnetizing force is removed is called *residual magnetism*. *Retentivity* is the property which causes a magnetic material to have residual magnetism after having been magnetized.

Hysteresis; Coercive Force *Hysteresis* is the characteristic of a magnetic system which causes a loss of power due to the fact that a negative magnetizing force must be applied to reduce the residual magnetism to zero. This negative force is termed *coercive force*. By "negative" magnetizing force is meant one which is of the opposite polarity with respect to the original magnetizing force. Hysteresis loss is apparent in transformers and chokes by the heating of the core.

Inductance If the switch shown in figure 17 is opened and closed, a pulsating direct current will be produced. When it is first closed, the current does not instantaneously rise to its maximum value, but builds up to it. While it is building up, the magnetic field is expanding around the conductor. Of course, this happens in a small fraction of a second. If the switch is then opened, the current stops and the magnetic field contracts quickly. This expanding and contracting field will induce a current in any other conductor that is part of a continuous circuit which it cuts. Such a field can be obtained in the way just mentioned by means of a vibrator interruptor, or by applying a.c. to the circuit in place of the battery. Varying the resistance of the circuit will also produce the same effect. This inducing of a current in a conductor due to a varying current in another conductor not in actual contact is called *electromagnetic induction*.

Self-inductance If an alternating current flows through a coil the varying magnetic field around each turn cuts itself and the adjacent turn and induces a voltage in the coil of opposite polarity to the applied e.m.f. The amount of induced voltage depends on the number of turns in the coil, the current flowing in the coil, and the number of lines of force thread-

ing the coil. The voltage so induced is known as a *counter e.m.f.* or *back e.m.f.*, and the effect is termed *self-induction*. When the applied voltage is building up, the counter e.m.f. opposes the rise; when the applied voltage is decreasing, the counter e.m.f. is of the same polarity and tends to maintain the current. Thus, it can be seen that self-inductance tends to prevent any change in the current in the circuit.

The storage of energy in a magnetic field is expressed in *joules* and is equal to $(LI^2)/2$. (A joule is equal to 1 watt-second. *L* is defined immediately following.)

The Unit of Inductance: Inductance is usually denoted by the letter *L*, and is expressed

The Henry in *henrys*. A coil has an inductance of 1 henry when a voltage of 1 volt is induced by a current change of 1 ampere per second. The henry, while commonly used in audio-frequency circuits, is too large for reference to inductance coils, such as those used in radio-frequency circuits; *millihenry* or *microhenry* is more commonly used, in the following manner:

$$1 \text{ henry} = 1000 \text{ millihenrys, or } 10^3 \text{ millihenrys.}$$

$$1 \text{ millihenry} = 1/1000 \text{ henry, .001 henry, or } 10^{-3} \text{ henry.}$$

$$1 \text{ microhenry} = 1/1,000,000 \text{ henry, .000001 henry, or } 10^{-6} \text{ henry.}$$

$$1 \text{ microhenry} = 1/1000 \text{ millihenry, .001, or } 10^{-3} \text{ millihenry.}$$

$$1000 \text{ microhenrys} = 1 \text{ millihenry.}$$

Mutual Inductance When one coil is near another, a varying current in one will produce a varying magnetic field which cuts the turns of the other coil, inducing a current in it. This induced current is also varying, and will therefore induce another current in the first coil. This reaction between two coupled circuits is called *mutual inductance*, and can be calculated and expressed in henrys. The symbol for mutual inductance is *M*. Two circuits thus joined are said to be *inductively coupled*.

The magnitude of the mutual inductance depends on the shape and size of the two circuits, their positions and distances apart, and the permeability of the medium. The extent to which two inductors are coupled is expressed by a relation known as *coefficient of coupling* (k). This is the ratio of the mutual inductance actually present to the maximum possible value.

Thus, when k is 1, the coils have the maximum quantity mutual induction.

The mutual inductance of two coils can be formulated in terms of the individual inductances and the coefficient of coupling:

$$M = k \sqrt{L_1 \times L_2}$$

For example, the mutual inductance of two coils, each with an inductance of 10 henrys and a coupling coefficient of 0.8 is:

$$M = 0.8 \sqrt{10 \times 10} = 0.8 \times 10 = 8$$

The formula for mutual inductance is $L = L_1 + L_2 + 2M$ when the coils are poled so that their fields add. When they are poled so that their fields buck, then $L = L_1 + L_2 - 2M$ (figure 19).

Inductors in Parallel Inductors in parallel are combined exactly as are resistors in parallel, provided that they are far enough apart so that the mutual inductance is entirely negligible.

Inductors in Series Inductors in series are additive, just as are resistors in series, again provided that no mutual inductance exists. In this case, the total inductance L is:

$$L = L_1 + L_2 + \dots, \text{ etc.}$$

Where mutual inductance does exist:

$$L = L_1 + L_2 + 2M$$

where,

M is the mutual inductance.

This latter expression assumes that the coils are connected in such a way that all flux linkages are in the same direction, i.e., additive. If this is not the case and the mutual linkages *subtract* from the self-linkages, the following formula holds:

$$L = L_1 + L_2 - 2M$$

where,

M is the mutual inductance.

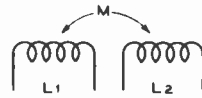

Figure 19

MUTUAL INDUCTANCE

The quantity M represents the mutual inductance between the two coils L_1 and L_2 .

Core Material Ordinary magnetic cores cannot be used for radio frequencies because the *eddy current and hysteresis losses* in the core material become enormous as the frequency is increased. The principal use for conventional magnetic cores is in the audio-frequency range below approximately 15,000 Hertz, whereas at very low frequencies (50 to 60 Hertz) their use is mandatory if an appreciable value of inductance is desired.

An air-core inductor of only 1 henry inductance would be quite large in size, yet values as high as 500 henrys are commonly available in small iron-core chokes. The inductance of a coil with a magnetic core will vary with the amount of current (both a-c and d-c) which passes through the coil. For this reason, iron-core chokes that are used in power supplies have a certain inductance rating at a *predetermined value of direct current*.

The permeability of air does not change with flux density; so the inductance of iron-core coils often is made less dependent on flux density by making part of the magnetic

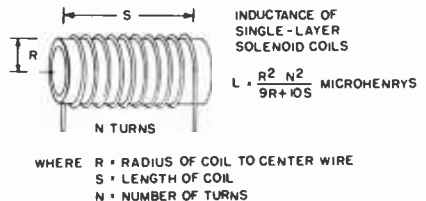

Figure 20

FORMULA FOR CALCULATING INDUCTANCE

Through the use of the equation and the sketch shown above the inductance of single-layer solenoid coils can be calculated with an accuracy of about one percent for the types of coils normally used in the hf and vhf range.

path air, instead of utilizing a closed loop of iron. This incorporation of an *air gap* is necessary in many applications of iron-core coils, particularly where the coil carries a considerable d-c component. Because the permeability of air is so much lower than that of iron, the air gap need comprise only a small fraction of the magnetic circuit in order to provide a substantial proportion of the total reluctance.

Iron-Core Inductors at Radio Frequencies Iron-core inductors may be used at radio frequencies if the iron is in a very finely divided form, as in the case of the powdered-iron cores used in some types of r-f coils and i-f transformers. These cores are made of extremely small particles of iron. The particles are treated with an insulating material so that each particle will be insulated from the others, and the treated powder is molded with a binder into cores. Eddy current losses are greatly reduced, with the result that these special iron cores are entirely practical in circuits which operate up to 100 MHz in frequency.

2-5 RC and RL Transients

A voltage divider may be constructed as shown in figure 21. Kirchhoff's and Ohm's Laws hold for such a divider. This circuit is known as an *RC circuit*.

Time Constant-RC and RL Circuits When switch S in figure 21 is placed in position 1, a voltmeter across capacitor C

will indicate the manner in which the capacitor will become charged through the resistor R from battery B. If relatively large values are used for R and C, and if a vacuum-tube voltmeter which draws negligible current is used to measure the voltage (*e*), the rate of charge of the capacitor may actually be plotted with the aid of a stop watch.

Voltage Gradient It will be found that the voltage (*e*) will begin to rise rapidly from zero the instant the switch is closed. Then, as the capacitor begins to charge, the rate of change of voltage across the capacitor will be found to decrease, the charging taking place more and more slowly

as capacitor voltage *e* approaches battery voltage *E*. Actually, it will be found that in any given interval a constant percentage of the remaining difference between *e* and *E* will be delivered to the capacitor as an increase in voltage. A voltage which changes in this manner is said to increase *logarithmically*, or follows an *exponential curve*.

Time Constant A mathematical analysis of the charging of a capacitor in this manner would show that the relationship between battery voltage *E* and the voltage across the capacitor (*e*) could be expressed in the following manner:

$$e = E (1 - \epsilon^{-t/RC})$$

where *e*, *E*, *R*, and *C* have the values discussed above, $\epsilon = 2.716$ (the base of Naperian or natural logarithms), and *t* represents the time which has elapsed since the closing of

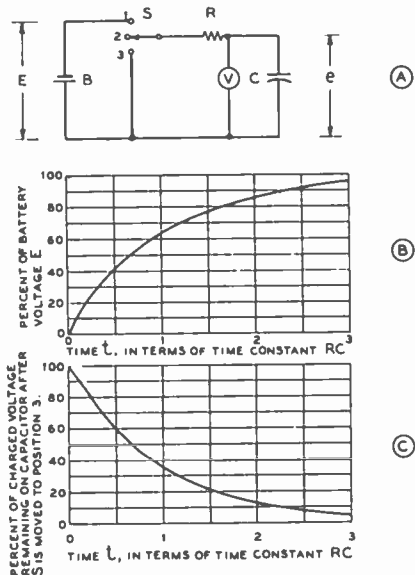

Figure 21

TIME CONSTANT OF AN RC CIRCUIT

Shown at (A) is the circuit upon which is based the curves of (B) and (C). (B) shows the rate at which capacitor C will charge from the instant at which switch S is placed in position 1. (C) shows the discharge curve of capacitor C from the instant at which switch S is placed in position 3.

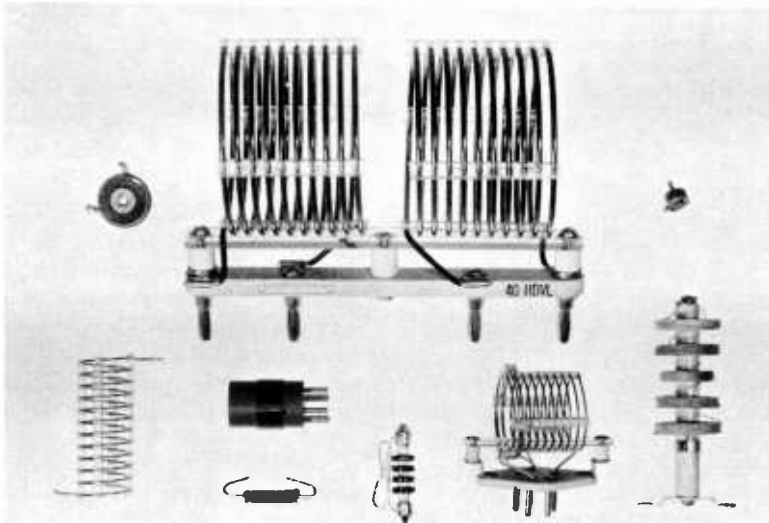

Figure 22

TYPICAL INDUCTANCES

The large inductance is a 1000-watt transmitting coil. To the right and left of this coil are small r-f chokes. Several varieties of low power capability coils are shown below, along with various types of r-f chokes intended for high-frequency operation.

the switch. With t expressed in seconds, R and C may be expressed in farads and ohms, or R and C may be expressed in microfarads

and megohms. The product RC is called the *time constant* of the circuit, and is expressed in seconds. As an example, if R is one megohm and C is one microfarad, the time constant RC will be equal to the product of the two, or one second.

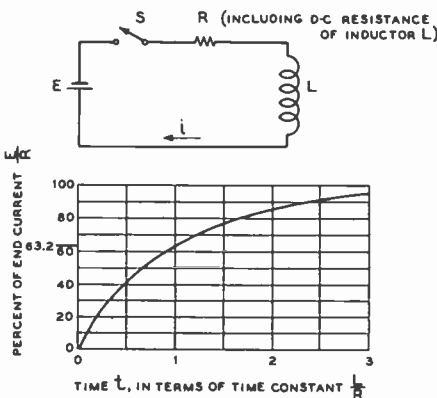

Figure 23

TIME CONSTANT OF AN RL CIRCUIT

Note that the time constant for the increase in current through an RL circuit is identical to the rate of increase in voltage across the capacitor in an RC circuit.

When the elapsed time (t) is equal to the time constant of the RC network under consideration, the exponent of ϵ becomes -1 . Now ϵ^{-1} is equal to $1/\epsilon$, or $1/2.716$, which is 0.368 . The quantity $(1-0.368)$ then is equal to 0.632 . Expressed as percentage, the above means that the voltage across the capacitor will have increased to 63.2 percent of the battery voltage in an interval equal to the time constant or RC product of the circuit. Then, during the next period equal to the time constant of the RC combination, the voltage across the capacitor will have risen to 63.2 per cent of the remaining difference in voltage, or 86.5 per cent of the applied voltage (E).

RL Circuit In the case of a series combination of a resistor and an inductor, as shown in figure 23, the current through the combination follows a very similar law

to that given above for the voltage appearing across the capacitor in an RC series circuit. The equation for the current through the combination is:

$$i = \frac{E}{R} (1 - e^{-t/RL})$$

where i represents the current at any instant through the series circuit, E represents the applied voltage, and R represents the total resistance of the resistor and the d-c resistance of the inductor in series. Thus the time

constant of the RL circuit is L/R , with R expressed in ohms and L expressed in henrys.

Voltage Decay When the switch in figure 21 is moved to position 3 after the capacitor has been charged, the capacitor voltage will drop in the manner shown in figure 21-C. In this case the voltage across the capacitor will decrease to 36.8 percent of the initial voltage (will make 63.2 per cent of the total drop) in a period of time equal to the time constant of the RC circuit.

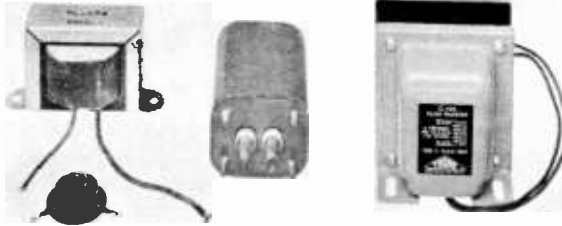

Figure 24

TYPICAL IRON-CORE INDUCTANCES

At the right is an upright mounting filter choke intended for use in low-powered transmitters and audio equipment. At the center is a hermetically sealed inductance for use under poor environmental conditions. To the left is an inexpensive receiving-type choke, with a small iron-core r-f choke directly in front of it.

Alternating-Current Circuits

The previous chapter has been devoted to a discussion of circuits and circuit elements upon which is impressed a current consisting of a flow of electrons in one direction. This type of unidirectional current flow is called direct current (abbreviated *d-c* or *d.c.*). Equally as important in radio and communications work and power practice is a type of current whose direction of electron flow reverses periodically. The reversal of flow may take place at a low rate, in the case of power systems, or it may take place millions of times per second, in the case of communications frequencies. This type of current flow is called *alternating current* (abbreviated *a-c* or *a.c.*).

3-1 Alternating Current

Frequency of an Alternating Current An alternating current is one whose amplitude of current flow periodically rises from zero to a maximum in one direction, decreases to zero, changes its direction, rises to maximum in the opposite direction, and decreases to zero again. This complete process, starting from zero, passing through two maximums in opposite directions, and returning to zero again, is called a *cycle*. The number of times per second that a current passes through the complete cycle is called the *frequency* (f) of the current. One and one-quarter cycles of an alternating current wave are illustrated diagrammatically in figure 1.

Frequency Spectrum At present the usable frequency range for alternating electrical currents extends over the electromagnetic spectrum from about 15 cycles per second to perhaps 30,000,000,000 cycles per second. It is obviously cumbersome to use a frequency designation in c.p.s. for enormously high frequencies, so three common units which are multiples of one cycle per second were established and are still used by many engineers.

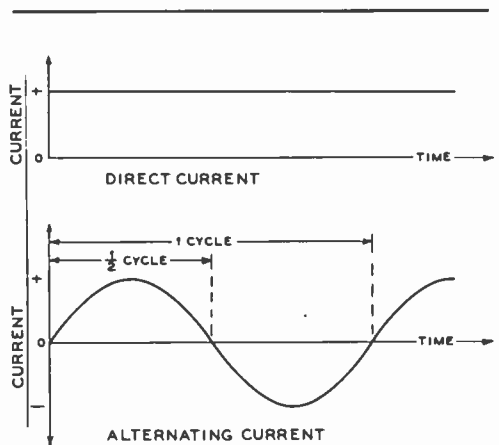

Figure 1

ALTERNATING CURRENT AND DIRECT CURRENT

Graphical comparison between unidirectional (direct) current and alternating current as plotted against time.

These units have been:

- (1) the kilocycle (kc), 1000 c.p.s.
- (2) The megacycle (Mc), 1,000,000 c.p.s. or 1000 kc.
- (3) the kilomegacycle (kMc), 1,000,000,000 c.p.s. or 1000 Mc.

Used for some time in other countries, and recently adopted by the U. S. National Bureau of Standards, IEEE, and many other American organizations, the *Hertz* is the new unit of frequency measurement.

One *Hertz* is precisely defined as *one cycle per second* and is not to be confused with any other time base. Hertz is abbreviated as *Hz* (no period). The standard metric prefixes for *kilo*, *mega*, *giga*, etc. are used with the basic unit. Since "m" denotes "milli," capital "M" is used for mega, and small "k" is kilo. Thus megacycle becomes *megahertz* (MHz), kilocycle is *kilohertz* (kHz).

These newer units will be used throughout this Handbook. With easily handled units such as these we can classify the entire usable frequency range into frequency bands.

The frequencies falling between about 15 and 20,000 hertz are called *audio* frequencies (abbreviated *a.f.*), since these frequencies are audible to the human ear when converted from electrical to acoustical signals by a speaker or headphone. Frequencies in the vicinity of 60 Hz also are called *power* frequencies, since they are commonly used to distribute electrical power to the consumer.

The frequencies falling between 10,000 c.p.s. (10 kHz) and 30,000,000,000 c.p.s. (30 GHz) are commonly called *radio* frequencies (abbreviated *r.f.*), since they are commonly used in radio communication and allied arts. The radio-frequency spectrum is often arbitrarily classified into seven frequency bands, each one of which is ten times as high in frequency as the one just below it in the spectrum (except for the vlf band at the bottom end of the spectrum). The present spectrum, with classifications, is given in the following table.

Frequency	Classification	Abbrev.
10 to 30 kHz	Very-low frequencies	vlf
30 to 300 kHz	Low frequencies	lf
300 to 3000 kHz	Medium frequencies	mf
3 to 30 MHz	High frequencies	hf
30 to 300 MHz	Very-high frequencies	vhf
300 to 3000 MHz	Ultrahigh frequencies	uhf
3 to 30 GHz	Superhigh frequencies	shf
30 to 300 GHz	Extremely high frequencies	ehf

rent will flow in the conductor. He also discovered that, when a conductor in a second closed circuit is brought near the first conductor and the current in the first one is varied, a current will flow in the second conductor. This effect is known as *induction*, and the currents so generated are *induced currents*. In the latter case it is the lines of force which are moving and cutting the second conductor, due to the varying current strength in the first conductor.

A current is induced in a conductor if there is a relative motion between the conductor and a magnetic field, its direction of flow depending on the direction of the relative motion between the conductor and the field, and its strength depends on the intensity of the field, the rate of cutting lines of force, and the number of turns in the conductor.

Alternators A machine that generates an alternating current is called an *alternator* or *a-c* generator. Such a machine in its basic form is shown in figure 2. It consists of two permanent magnets, the opposite poles of which face each other and are

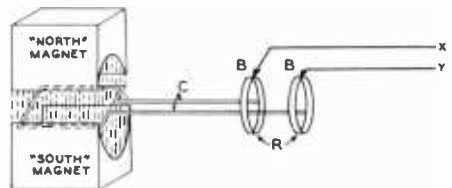

Figure 2

THE ALTERNATOR

Semi-schematic representation of the simplest form of the alternator.

Generation of Alternating Current Faraday discovered that if a conductor which forms part of a closed circuit is moved through a magnetic field so as to cut across the lines of force, a cur-

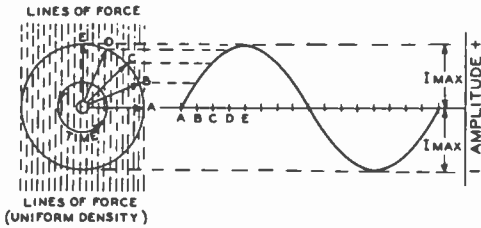

Figure 3

OUTPUT OF THE ALTERNATOR

Graph showing sine-wave output current of the alternator of figure 2.

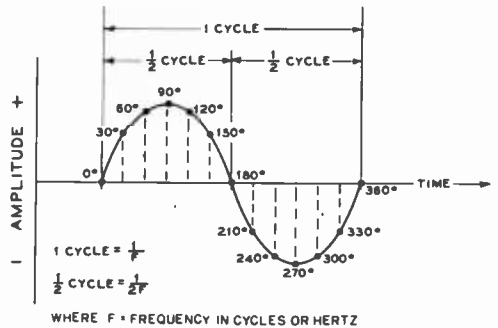

Figure 4

THE SINE WAVE

Illustrating one cycle of a sine wave. One complete cycle of alternation is broken up into 360 degrees. Then one-half cycle is 180 degrees, one-quarter cycle is 90 degrees, and so on down to the smallest division of the wave. A cosine wave has a shape identical to a sine wave but is shifted 90 degrees in phase — in other words the wave begins at full amplitude, the 90-degree point comes at zero amplitude, the 180-degree point comes at full amplitude in the opposite direction of current flow, etc.

machined so that they have a common radius. Between these two poles (north and south) a substantially constant magnetic field exists. If a conductor in the form of a loop (C) is suspended so that it can be freely rotated between the two poles, and if the opposite ends of conductor C are brought to collector rings (R) and brushes (B) to the external circuit (X-Y).

The field intensity between the two pole pieces is substantially constant over the entire area of the pole face. However, when the conductor is moving parallel to the lines of force at the top or bottom of the pole faces, no lines are being cut. As the conductor moves on across the pole face it cuts more and more lines of force for each unit distance of travel, until it is cutting the maximum number of lines when opposite the center of the pole. Therefore, zero current is induced in the conductor at the instant it is midway between the two poles, and maximum current is induced when it is opposite the center of the pole face. After the conductor has rotated through 180° it can be seen that its position with respect to the pole pieces will be exactly opposite to that when it started. Hence, the second 180° of rotation will produce an alternation of current in the opposite direction to that of the first alternation.

The current does *not* increase directly as the angle of rotation, but rather as the *sine* of the angle; hence, such a current has the mathematical form of a *sine wave*. Although most electrical machinery does not produce

a strictly pure sine curve, the departures are usually so slight that the assumption can be regarded as fact for most practical purposes. All that has been said in the foregoing paragraphs concerning alternating current also is applicable to alternating voltage.

The rotating arrow to the left in figure 3 represents a conductor rotating in a constant magnetic field of uniform density. The arrow also can be taken as a *vector* representing the strength of the magnetic field. This means that the length of the arrow is determined by the strength of the field (number of lines of force), which is constant. Now if the arrow is rotating at a constant rate (that is, with constant *angular velocity*), then the voltage developed across the conductor will be proportional to the rate at which it is cutting lines of force, which rate is proportional to the vertical distance between the tip of the arrow and the horizontal base line.

If EO is taken as unity, or a voltage of 1, then the voltage (vertical distance from tip of arrow to the horizontal base line) at point C for instance may be determined simply by referring to a table of sines and looking up the sine of the angle which the arrow makes with the horizontal.

When the arrow has traveled from point A to point E, it has traveled 90 degrees or one quarter cycle. The other three quadrants are not shown because their complementary or mirror relationship to the first quadrant is obvious.

It is important to note that time units are represented by *degrees* or quadrants. The fact that AB, BC, CD, and DE are equal chords (forming equal quadrants) simply means that the arrow (conductor or vector) is traveling at a constant speed, because these points on the radius represent the passage of equal units of time.

The whole picture can be represented in another way, and its derivation from the foregoing is shown in figure 3. The time base is represented by a straight line rather than by angular rotation. Points A, B, C, etc., represent the same units of time as before. When the voltage corresponding to each point is projected to the corresponding time unit, the familiar *sine curve* is the result.

The frequency of the generated voltage is proportional to the speed of rotation of the alternator, and to the number of magnetic poles in the field. Alternators may be built to produce radio frequencies up to 30 kHz, and some such machines are still used for low-frequency communication purposes. By means of multiple windings, three-phase output may be obtained from large industrial alternators.

Radian Notation From figure 1 we see that the value of an a-c wave varies continuously. It is often of importance to know the amplitude of the wave in terms of the total amplitude at any instant or at any time within the cycle. To be able to establish the instant in question we must be able to divide the cycle into parts. We could divide the cycle into eighths, hundredths, or any other ratio that suited our fancy. However, it is much more convenient mathematically to divide the cycle either into *electrical degrees* (360° represent one cycle) or into *radians*. A radian is an arc of a circle equal to the radius of the circle; hence there are 2π radians per cycle—or per circle (since there are π diameters per circumference, there are 2π radii).

Both radian notation and electrical-degree notation are used in discussions of alternat-

ing-current circuits. However, trigonometric tables are much more readily available in terms of degrees than radians, so the following simple conversions are useful.

$$2\pi \text{ radians} = 1 \text{ cycle} = 360^\circ$$

$$\pi \text{ radians} = 1/2 \text{ cycle} = 180^\circ$$

$$\frac{\pi}{2} \text{ radians} = 1/4 \text{ cycle} = 90^\circ$$

$$\frac{\pi}{3} \text{ radians} = 1/6 \text{ cycle} = 60^\circ$$

$$\frac{\pi}{4} \text{ radians} = 1/8 \text{ cycle} = 45^\circ$$

$$1 \text{ radian} = \frac{1}{2\pi} \text{ cycle} = 57.3^\circ$$

When the conductor in the simple alternator of figure 2 has made one complete revolution it has generated one cycle and has rotated through 2π radians. The expression $2\pi f$ then represents the number of radians in one cycle multiplied by the number of cycles per second (the frequency) of the alternating voltage or current. The expression then represents the number of radians per second through which the conductor has rotated. Hence $2\pi f$ represents the angular velocity of the rotating conductor, or of the rotating vector, which represents any alternating current or voltage, expressed in radians per second.

In technical literature the expression $2\pi f$ is often replaced by ω , the lower-case Greek letter *omega*. Velocity multiplied by time gives the distance travelled, so $2\pi f t$ (or ωt) represents the angular distance through which the rotating conductor or the rotating vector has travelled since the reference time $t = 0$. In the case of a sine wave the reference time $t = 0$ represents the instant when the voltage or the current, whichever is under discussion, also is equal to zero.

Instantaneous Value of Voltage or Current The instantaneous voltage or current is proportional to the sine of the angle through which the

rotating vector has travelled since reference time $t = 0$. Hence, when the peak value of the a-c wave amplitude (either voltage or current amplitude) is known, and the angle through which the rotating vector has

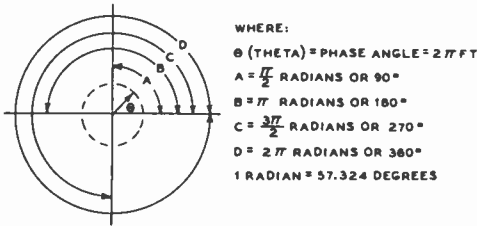

Figure 5

ILLUSTRATING RADIAN NOTATION

The radian is a unit of phase angle, equal to 57.324 degrees. It is commonly used in mathematical relationships involving phase angles since such relationships are simplified when radian notation is used.

travelled is established, the amplitude of the wave at this instant can be determined through use of the following expression:

$$e = E_{max} \sin 2\pi ft$$

where,

- e* equals the instantaneous voltage,
- E_{max} equals maximum peak value of voltage,
- f* equals frequency in hertz,
- t* equals period of time which has elapsed since $t = 0$ (expressed as a fraction of one second).

The instantaneous current can be found from the same expression by substituting *i* for *e* and I_{max} for E_{max} .

It is often easier to visualize the process of determining the instantaneous amplitude by ignoring the frequency and considering only one cycle of the a-c wave. In this case, for a sine wave, the expression becomes:

$$e = E_{max} \sin \theta$$

where θ represents the angle through which the vector has rotated since time (and amplitude) were zero. As examples:

when $\theta = 30^\circ$

$$\sin \theta = 0.5$$

so $e = 0.5 E_{max}$

.....

when $\theta = 60^\circ$

$$\sin \theta = 0.866$$

so $e = 0.866 E_{max}$

.....

when $\theta = 90^\circ$

$$\sin \theta = 1.0$$

so $e = E_{max}$

when $\theta = 1$ radian

$$\sin \theta = 0.8415$$

so $e = 0.8415 E_{max}$

Effective Value of an Alternating Current The instantaneous value of an alternating current or voltage varies continuously throughout the cycle, so some value of an a-c wave must be chosen to establish a relationship between the effectiveness of an a-c and a d-c voltage or current. The heating value of an alternating current has been chosen to establish the reference between the effective values of a.c. and d.c. Thus an alternating current will have an effective value of 1 ampere when it produces the same heat in a resistor as does 1 ampere of direct current.

The effective value is derived by taking the instantaneous values of current over a cycle of alternating current, squaring these values, taking an average of the squares, and then taking the square root of the average. By this procedure, the effective value becomes known as the *root mean square*, or rms, value. This is the value that is read on a-c voltmeters and a-c ammeters. The rms value is 70.7 percent of the peak or maximum instantaneous value (for sine waves only) and is expressed as follows:

$$E_{eff} \text{ or } E_{rms} = 0.707 \times E_{max} \text{ or}$$

$$I_{eff} \text{ or } I_{rms} = 0.707 \times I_{max}$$

The following relations are extremely useful in radio and power work:

$$E_{rms} = 0.707 \times E_{max}, \text{ and}$$

$$E_{max} = 1.414 \times E_{rms}$$

Rectified Alternating Current or Pulsating Direct Current If an alternating current is passed through a rectifier, it emerges in the form of a current of varying amplitude which flows in one direction only. Such a current is known as

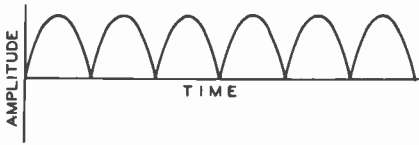

Figure 6

FULL-WAVE RECTIFIED SINE WAVE

Waveform obtained at the output of a full-wave rectifier being fed with a sine wave and having 100 per cent rectification efficiency. Each pulse has the same shape as one-half cycle of a sine wave. This type of current is known as pulsating direct current.

rectified a.c. or pulsating d.c. A typical wave form of a pulsating direct current as would be obtained from the output of a full-wave rectifier is shown in figure 6.

Measuring instruments designed for d-c operation will not read the peak or instantaneous maximum value of the pulsating d-c output from the rectifier; they will read only the *average value*. This can be explained by assuming that it could be possible to cut off some of the peaks of the waves, using the cutoff portions to fill in the spaces that are open, thereby obtaining an *average d-c value*. A milliammeter and voltmeter connected to the adjoining circuit, or across the output of the rectifier, will read this average value. It is related to *peak value* by the following expression:

$$E_{avg} = 0.636 \times E_{max}$$

It is thus seen that the average value is 63.6 percent of the peak value.

Relationship Between Peak, RMS, or Effective, and Average Values To summarize the three most significant values of an a-c sine wave: the peak value is equal to

1.41 times the rms or effective, and the rms value is equal to 0.707 times the peak value; the average value of a full-wave rectified a-c wave is 0.636 times the peak value, and the average value of a rectified wave is equal to 0.9 times the rms value.

$$rms = 0.707 \times peak$$

$$average = 0.636 \times peak$$

.....

$$average = 0.9 \times rms$$

$$rms = 1.11 \times average$$

$$peak = 1.414 \times rms$$

$$peak = 1.57 \times average$$

Applying Ohm's Law to Alternating Current Ohm's Law applies equally to direct or alternating current, provided

the circuits under consideration are purely resistive, that is, circuits which have neither inductance (coils) nor capacitance (capacitors). Problems which involve tube filaments, dropping resistors, electric lamps, heaters or similar resistive devices can be solved with Ohm's Law, regardless of whether the current is direct or alternating. When a capacitor or coil is made a part of the circuit, a property common to either, called *reactance*, must be taken into consideration. Ohm's Law still applies to a-c circuits containing reactance, but additional considerations are involved; these will be discussed in a later paragraph.

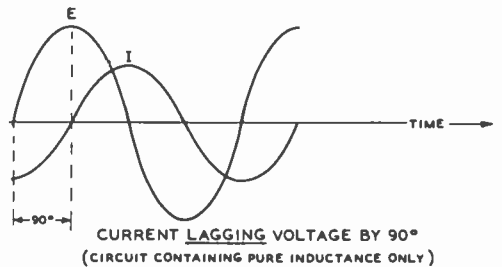

Figure 7

LAGGING PHASE ANGLE

Showing the manner in which the current lags the voltage in an a-c circuit containing pure inductance only. The lag is equal to one-quarter cycle or 90 degrees.

Inductive Reactance As was stated in Chapter Two, when a changing current flows through an inductor a back- or counterelectromotive force is developed, opposing any change in the initial current. This property of an inductor causes it to offer opposition or *impedance* to a change in current. The measure of impedance offered by an inductor to an alternating current of a given frequency is known as its *inductive*

reactance. This is expressed as X_L , and is shown in figure 7.

$$X_L = 2\pi fL$$

where,

- X_L equals inductive reactance expressed in ohms,
- π equals 3.1416 ($2\pi = 6.283$),
- f equals frequency in Hertz,
- L equals inductance in henrys.

Inductive Reactance at Radio Frequencies It is very often necessary to compute inductive reactance at radio frequencies. The same formula may be used, but to make it less cumbersome the inductance is expressed in *millihenrys* and the frequency in *kilobertz*. For higher frequencies and smaller values of inductance, frequency is expressed in *megabertz* and inductance in *microhenrys*. The basic equation need not be changed, since the multiplying factors for inductance and frequency appear in numerator and denominator, and hence are cancelled out. However, it is not possible in the same equation to express L in millihenrys and f in Hertz without conversion factors.

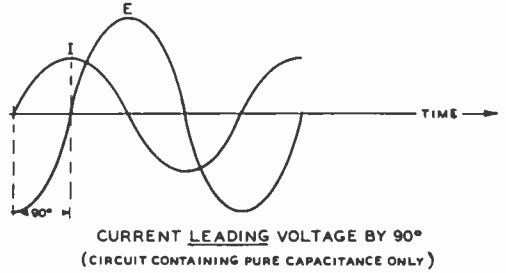

Figure 8
LEADING PHASE ANGLE

Showing the manner in which the current leads the voltage in an a-c circuit containing pure capacitance only. The lead is equal to one-quarter cycle or 90 degrees.

Capacitive Reactance It has been explained that inductive reactance is the measure of the ability of an inductor to offer impedance to the flow of an alternating current. Capacitors have a similar property although in this case the opposition is to any change in the voltage across the capacitor. This property is called *capacitive reactance* and is expressed as follows:

Table 1. Quantities, Units, and Symbols

Symbol	Quantity	Unit	Abbreviation
f	Frequency	hertz	Hz
λ	Wavelength	meter	M
X_L	Inductive Reactance	ohm	Ω
X_C	Capacitive Reactance	ohm	Ω
Q	Figure of merit	$\frac{\text{reactance}}{\text{resistance}}$	—
Z	Impedance	ohm	Ω

- = instantaneous value of voltage
- E_{\max} = peak value of voltage
- i = instantaneous value of current
- I_{\max} = peak value of current
- θ = phase angle, expressed in degrees
- E_{eff} or E_{rms} = effective or rms value of voltage
- I_{eff} or I_{rms} = effective or rms value of current
- j = vector operator (90° rotation)

$$X_C = \frac{1}{2\pi fC}$$

where,

- X_C equals capacitive reactance in ohms,
- π equals 3.1416,
- f equals frequency in Hertz,
- C equals capacitance in farads.

Capacitive Reactance at Radio Frequencies Here again, as in the case of inductive reactance, the units of capacitance and frequency can be converted into smaller units for practical problems encountered in radio work. The equation may be written:

$$X_C = \frac{1,000,000}{2\pi fC}$$

where,

- f equals frequency in megahertz,
- C equals capacitance in picofarads.

In the audio range it is often convenient to express frequency (f) in *Hertz* and capacitance (C) in *microfarads*, in which event the same formula applies.

Phase When an alternating current flows through a purely resistive circuit, it will be found that the current will go through maximum and minimum in perfect step with the voltage. In this case the current is said to be in step, or *in phase* with the voltage. For this reason, Ohm's Law will apply equally well for *a.c.* or *d.c.* where pure resistances are concerned, provided that the same values of the wave (either peak or rms) for both voltage and current are used in the calculations.

However, in calculations involving alternating currents the voltage and current are not necessarily in phase. The current through the circuit may lag behind the voltage, in which case the current is said to have *lagging* phase. Lagging phase is caused by inductive reactance. If the current reaches its maximum value ahead of the voltage (figure 8) the current is said to have a *leading* phase. A leading phase angle is caused by capacitive reactance.

In an electrical circuit containing reactance only, the current will either lead or

lag the voltage by 90° . If the circuit contains inductive reactance only, the current will lag the voltage by 90° . If only capacitive reactance is in the circuit, the current will lead the voltage by 90° .

Reactances in Combination Inductive and capacitive reactance have exactly opposite effects on the phase relation between current and voltage in a circuit. Hence when they are used in combination their effects tend to neutralize. The combined effect of a capacitive and an inductive reactance is often called the *net reactance* of a circuit. The net reactance (X) is found by subtracting the capacitive reactance from the inductive reactance ($X = X_L - X_C$).

The result of such a combination of pure reactances may be either positive, in which case the positive reactance is greater so that the net reactance is inductive, or it may be negative in which case the capacitive reactance is greater so that the net reactance is capacitive. The net reactance may also be zero in which case the circuit is said to be *resonant*. The condition of resonance will be discussed in a later section. Note that inductive reactance is always taken as being positive while capacitive reactance is always taken as being negative.

Impedance; Circuits Containing Reactance and Resistance Pure reactances introduce a phase angle of 90° between voltage and current; pure resistance introduces no phase shift between voltage and current. Hence we cannot add a reactance and a resistance directly. When a reactance and a resistance are used in

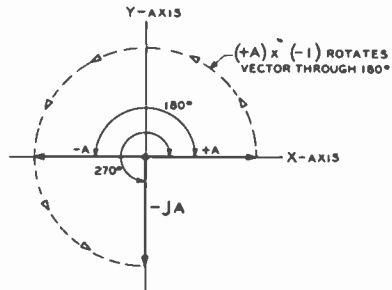

Figure 9

Operation on the vector (+A) by the quantity (-1) causes vector to rotate through 180 degrees.

combination the resulting phase angle of current flow with respect to the impressed voltage lies somewhere between plus or minus 90° and 0° depending on the relative magnitudes of the reactance and the resistance.

The term *impedance* is a general term which can be applied to any electrical entity which impedes the flow of current. Hence the term may be used to designate a resistance, a pure reactance, or a complex combination of both reactance and resistance. The designation for impedance is Z . An impedance must be defined in such a manner that both its magnitude and its phase angle are established. The designation may be accomplished in either of two ways—one of which is convertible into the other by simple mathematical operations.

The j Operator The first method of designating an impedance is actually to specify both the resistive and the reactive component in the form $R + jX$. In this form R represents the resistive component in ohms and X represents the reactive component. The j merely means that the X component is reactive and thus cannot be added directly to the R component. Plus jX means that the reactance is positive or inductive, while if minus jX were given it would mean that the reactive component was negative or capacitive.

In figure 9 we have a vector ($+A$) lying along the positive X -axis of the usual X - Y coordinate system. If this vector is multiplied by the quantity (-1) , it becomes $(-A)$ and its position now lies along the X -axis in the negative direction. The operator (-1) has caused the vector to rotate through an angle of 180 degrees. Since (-1) is equal to $(\sqrt{-1} \times \sqrt{-1})$, the same result may be obtained by operating on the vector with the operator $(\sqrt{-1} \times \sqrt{-1})$. However if the vector is operated on but once by the operator $(\sqrt{-1})$, it is caused to rotate only 90 degrees (figure 10). Thus the operator $(\sqrt{-1})$ rotates a vector by 90 degrees. For convenience, this operator is called the *j operator*. In like fashion, the operator $(-j)$ rotates the vector of figure 9 through an angle of 270 degrees, so that the resulting vector $(-jA)$ falls on the $(-Y)$ axis of the coordinate system.

Polar Notation The second method of representing an impedance is to specify its absolute magnitude and the phase angle of current with respect to voltage, in the form $Z \angle \theta$. Figure 11 shows graphically the relationship between the two common ways of representing an impedance.

The construction of figure 11 is called an *impedance diagram*. Through the use of such a diagram we can add graphically a resistance and a reactance to obtain a value for the resulting impedance in the scalar form. With zero at the origin, resistances are plotted to the right, positive values of reactance (inductive) in the upward direction, and negative values of reactance (capacitive) in the downward direction.

Note that the resistance and reactance are drawn as the two sides of a right triangle, with the hypotenuse representing the resulting impedance. Hence it is possible to determine mathematically the value of a resultant impedance through the familiar right-triangle relationship—the square of the hypotenuse is equal to the sum of the squares of the other two sides:

$$Z^2 = R^2 + X^2$$

or,

$$|Z| = \sqrt{R^2 + X^2}$$

Note also that the angle θ included between R and Z can be determined from any of the following trigonometric relationships:

$$\sin \theta = \frac{X}{|Z|}$$

$$\cos \theta = \frac{R}{|Z|}$$

$$\tan \theta = \frac{X}{R}$$

One common problem is that of determining the *scalar magnitude* of the impedance, $|Z|$, and the phase angle θ , when resistance and reactance are known; hence, of converting from the $Z = R + jX$ to the $|Z| \angle \theta$ form. In this case we use two of the expressions just given:

$$|Z| = \sqrt{R^2 + X^2}$$

$$\tan \theta = \frac{X}{R}, \text{ (or } \theta = \tan^{-1} \frac{X}{R} \text{)}$$

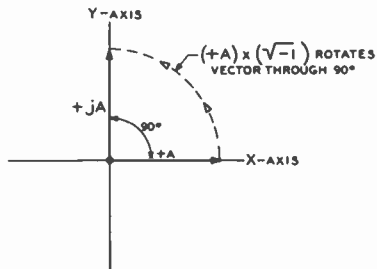

Figure 10

Operation on the vector $(+A)$ by the quantity (j) causes vector to rotate through 90 degrees.

The inverse problem, that of converting from the $|Z| \angle \theta$ to the $R + jX$ form is done with the following relationships, both of which are obtainable by simple division from the trigonometric expressions just given for determining the angle θ :

$$R = |Z| \cos \theta$$

$$jX = |Z| j \sin \theta$$

By simple addition these two expressions may be combined to give the relationship between the two most common methods of indicating an impedance:

$$R + jX = |Z| (\cos \theta + j \sin \theta)$$

In the case of impedance, resistance, or reactance, the unit of measurement is the

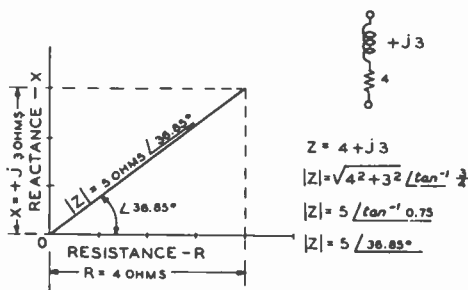

Figure 11

THE IMPEDANCE TRIANGLE

Showing the graphical construction of a triangle for obtaining the net (scalar) impedance resulting from the connection of a resistance and a reactance in series. Shown also alongside is the alternative mathematical procedure for obtaining the values associated with the triangle.

ohm; hence, the ohm may be thought of as a unit of *opposition to current flow*, without reference to the relative phase angle between the applied voltage and the current which flows.

Further, since both capacitive and inductive reactance are functions of frequency, impedance will vary with frequency. Figure 12 shows the manner in which $|Z|$ will vary with frequency in an RL series circuit and in an RC series circuit.

Series RLC Circuits In a series circuit containing R , L , and C , the impedance is determined as discussed before except that the reactive component in the expressions defines the net reactance—that is, the difference between X_L and X_C . Hence $(X_L - X_C)$ may be substituted for X in the equations. Thus:

$$|Z| = \sqrt{R^2 + (X_L - X_C)^2}$$

$$\theta = \tan^{-1} \frac{(X_L - X_C)}{R}$$

A series RLC circuit thus may present an impedance which is capacitively reactive if the net reactance is capacitive, inductively reactive if the net reactance is inductive, or resistive if the capacitive and inductive reactances are equal.

Addition of Complex Quantities The addition of complex quantities (for example, impedances in series) is quite simple if the quantities are in the rectangular form. If they are in the polar form they only can be added graphically, unless they are converted to the rectangular form by the relationships previously given. As an example of the addition of complex quantities in the rectangular form, the equation for the addition impedance is:

$$(R_1 + jX_1) + (R_2 + jX_2) = (R_1 + R_2) + j(X_1 + X_2)$$

For example if we wish to add the impedances $(10 + j50)$ and $(20 - j30)$ we obtain:

$$\begin{aligned} (10 + j50) + (20 - j30) &= (10 + 20) + j[50 + (-30)] \\ &= 30 + j(50 - 30) \\ &= 30 + j20 \end{aligned}$$

Multiplication and Division of Complex Quantities It is often necessary in solving certain types of circuits to multiply or divide two complex quantities. It is a much simpler mathematical operation to multiply or divide complex quantities if they are expressed in the polar form. Hence if they are given in the rectangular form they should be converted to the polar form before multiplication or division is begun. Then the multiplication is accomplished by multiplying the $|Z|$ terms together and adding algebraically the $\angle \theta$ terms, as:

$$(|Z_1| \angle \theta_1) (|Z_2| \angle \theta_2) = |Z_1| |Z_2| (\angle \theta_1 + \angle \theta_2)$$

For example, suppose that the two impedances $|20| \angle 43^\circ$ and $|32| \angle -23^\circ$ are to be multiplied. Then:

$$(|20| \angle 43^\circ) (|32| \angle -23^\circ) = |20 \cdot 32| (\angle 43^\circ + \angle -23^\circ) = 640 \angle 20^\circ$$

Division is accomplished by dividing the denominator into the numerator, and subtracting the angle of the denominator from that of the numerator, as:

$$\frac{|Z_1| \angle \theta_1}{|Z_2| \angle \theta_2} = \frac{|Z_1|}{|Z_2|} (\angle \theta_1 - \angle \theta_2)$$

For example, suppose that an impedance of $|50| \angle 67^\circ$ is to be divided by an impedance of $|10| \angle 45^\circ$. Then:

$$\frac{|50| \angle 67^\circ}{|10| \angle 45^\circ} = \frac{|50|}{|10|} (\angle 67^\circ - \angle 45^\circ) = |5| (\angle 22^\circ)$$

Ohm's Law for Complex Quantities The simple form of Ohm's Law used for d-c circuits may be stated in a more general form for application to a-c circuits involving either complex quantities or simple resistive elements. The form is:

$$I = \frac{E}{Z}$$

in which, in the general case, I , E , and Z are complex (vector) quantities. In the simple case where the impedance is a pure resistance with an a-c voltage applied, the equation simplifies to the familiar $I = E/R$. In any case the applied voltage may be expressed either as peak, rms, or average; the resulting current always will be in the same type used to define the voltage.

In the more general case vector algebra must be used to solve the equation. And, since either division or multiplication is involved, the complex quantities should be expressed in the polar form. As an example, take the case of the series circuit shown in figure 13 with 100 volts applied. The impedance of the series circuit can best be obtained first in the rectangular form, as:

$$200 + j(100 - 300) = 200 - j200$$

Now, to obtain the current we must convert this impedance to the polar form.

$$\begin{aligned} |Z| &= \sqrt{200^2 + (-200)^2} \\ &= \sqrt{40,000 + 40,000} \\ &= \sqrt{80,000} \\ &= 282 \Omega \end{aligned}$$

$$\begin{aligned} \theta &= \tan^{-1} \frac{X}{R} = \tan^{-1} \frac{-200}{200} = \tan^{-1}(-1) \\ &= -45^\circ \end{aligned}$$

Therefore, $Z = 282 \angle -45^\circ$

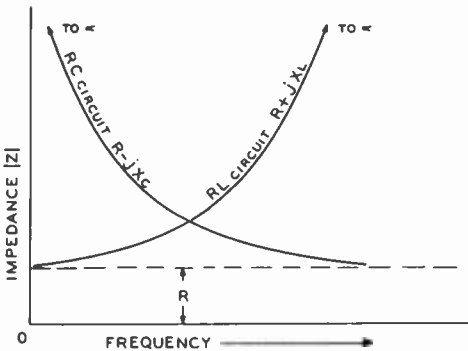

Figure 12

IMPEDANCE—FREQUENCY GRAPH FOR RL AND RC CIRCUITS

The impedance of an RC circuit approaches infinity as the frequency approaches zero (d.c.), while the impedance of a series RL circuit approaches infinity as the frequency approaches infinity. The impedance of an RC circuit approaches the impedance of the series resistor as the frequency approaches infinity, while the impedance of a series RL circuit approaches the resistance as the frequency approaches zero.

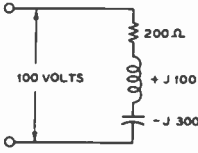

Figure 13

SERIES RLC CIRCUIT

Note that in a series circuit the resulting impedance takes the sign of the largest reactance in the series combination.

Where a slide rule is being used to make the computations, the impedance may be found without any addition or subtraction operations by finding the angle θ first, and then using the trigonometric equation below for obtaining the impedance. Thus:

$$\theta = \tan^{-1} \frac{X}{R} = \tan^{-1} \frac{-200}{200} = \tan^{-1}(-1) = -45^\circ.$$

Then, Z equals $\frac{-R}{\cos \theta}$

and $\cos -45^\circ = 0.707$

$$|Z| = \frac{200}{0.707} = 282 \text{ ohms}$$

Since the applied voltage will be the reference for the currents and voltages within the circuit, we may define it as having a zero phase angle: $E = 100 \angle 0^\circ$. Then:

$$I = \frac{100 \angle 0^\circ}{282 \angle -45^\circ} = 0.354 \angle 0^\circ - (-45^\circ) = 0.354 \angle 45^\circ \text{ amperes}$$

This same current must flow through all three elements of the circuit, since they are in series and the current through one must already have passed through the other two. Hence the voltage drop across the resistor (whose phase angle of course is 0°) is:

$$E = IR$$

$$E = (0.354 \angle 45^\circ) (200 \angle 0^\circ) = 70.8 \angle 45^\circ \text{ volts}$$

The voltage drop across the inductive reactance is:

$$E = IX_L$$

$$E = (0.354 \angle 45^\circ) (100 \angle 90^\circ) = 35.4 \angle 135^\circ \text{ volts}$$

Similarly, the voltage drop across the capacitive reactance is:

$$E = IX_C$$

$$E = (0.354 \angle 45^\circ) (300 \angle -90^\circ) = 106.2 \angle -45^\circ$$

Note that the voltage drop across the capacitive reactance is greater than the supply voltage. This condition often occurs in a series RLC circuit, and is explained by the fact that the drop across the capacitive reactance is cancelled to a lesser or greater extent by the drop across the inductive reactance.

It is often desirable in a problem such as the above to check the validity of the answer by adding vectorially the voltage drops across the components of the series circuit to make sure that they add up to the supply voltage — or to use the terminology of Kirchhoff's Second Law, to make sure that the voltage drops across all elements of the circuit, including the source taken as negative, is equal to zero.

In the general case of the addition of a number of voltage vectors in series it is best to resolve the voltages into their in-phase and out-of-phase components with respect to the supply voltage. Then these components may be added directly. Hence:

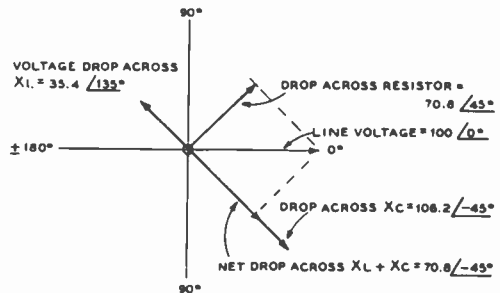

Figure 14

Graphical construction of the voltage drops associated with the series RLC circuit of figure 13.

$$\begin{aligned}
 E_R &= 70.8 \angle 45^\circ \\
 &= 70.8 (\cos 45^\circ + j \sin 45^\circ) \\
 &= 70.8 (0.707 + j0.707) \\
 &= 50 + j50 \\
 \dots \dots \dots \\
 E_L &= 35.4 \angle 135^\circ \\
 &= 35.4 (\cos 135^\circ + j \sin 135^\circ) \\
 &= 35.4 (-0.707 + j0.707) \\
 &= -25 + j25 \\
 \dots \dots \dots \\
 E_C &= 106.2 \angle 45^\circ \\
 &= 106.2 (\cos -45^\circ + j \sin -45^\circ) \\
 &= 106.2 (0.707 - j0.707) \\
 &= 75 - j75 \\
 \dots \dots \dots \\
 E_R + E_L + E_C &= (50 + j50) \\
 &\quad + (-25 + j25) + (75 - j75) \\
 &= (50 - 25 + 75) + \\
 &\quad j(50 + 25 - 75) \\
 E_R + E_L + E_C &= 100 + j0 \\
 &= 100 \angle 0^\circ,
 \end{aligned}$$

which is equal to the supply voltage.

Checking by Construction on the Complex Plane It is frequently desirable to check computations involving complex quantities by constructing vectors representing the quantities on the complex plane. Fig. 14 shows such a construction for the quantities of the problem just completed. Note that the answer to the problem may be checked by constructing a parallelogram with the voltage drop across the resistor as one side and the net voltage drop across the capacitor plus the inductor (these may be added algebraically as they are 180° out of phase) as the adjacent side. The vector sum of these two voltages, which is represented by the diagonal of the parallelogram, is equal to the supply voltage of 100 volts at zero phase angle.

Resistance and Reactance in Parallel In a series circuit, such as just discussed, the current through all the elements which go to make up the series cir-

cuit is the same. But the voltage drops across each of the components are, in general, different from one another. Conversely, in a parallel RLC or RX circuit the voltage is, obviously, the same across each of the elements. But the currents through each of the elements are usually different.

There are many ways of solving a problem involving paralleled resistance and reactance; several of these ways will be described. In general, it may be said that the impedance of a number of elements in parallel is solved using the same relations as are used for solving resistors in parallel, except that complex quantities are employed. The basic relation is:

$$\frac{1}{Z_{Total}} = \frac{1}{Z_1} + \frac{1}{Z_2} + \frac{1}{Z_3} + \dots,$$

or when only two impedances are involved:

$$Z_{Total} = \frac{Z_1 Z_2}{Z_1 + Z_2}$$

As an example, using the two-impedance relation, take the simple case, illustrated in figure 15, of a resistance of 6 ohms in parallel with a capacitive reactance of 4 ohms. To simplify the first step in the computation it is best to put the impedances in the polar form for the numerator, since multiplication is involved, and in the rectangular form for the addition in the denominator.

$$\begin{aligned}
 Z_{Total} &= \frac{(6 \angle 0^\circ) (4 \angle -90^\circ)}{6 - j4} \\
 &= \frac{24 \angle -90^\circ}{6 - j4}
 \end{aligned}$$

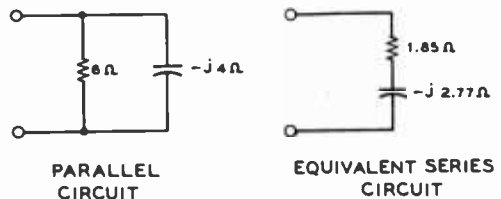

Figure 15

THE EQUIVALENT SERIES CIRCUIT

Showing a parallel RC circuit and the equivalent series RC circuit which represents the same net impedance as the parallel circuit.

Then the denominator is changed to the polar form for the division operation:

$$\theta = \tan^{-1} \frac{-4}{6} = \tan^{-1} -0.667 = -33.7^\circ$$

$$|Z| = \frac{6}{\cos -33.7^\circ} = \frac{6}{0.832} = 7.21 \text{ ohms}$$

$$6 - j4 = 7.21 \angle -33.7^\circ$$

Then:

$$Z_{\text{Total}} = \frac{24 \angle -90^\circ}{7.21 \angle -33.7^\circ} = 3.33 \angle -56.3^\circ$$

$$= 3.33 (\cos -56.3^\circ + j \sin -56.3^\circ)$$

$$= 3.33 [0.5548 + j (-0.832)]$$

$$= 1.85 - j 2.77$$

Equivalent Series Circuit Through the series of operations in the previous paragraph we have converted a circuit composed of two impedances in parallel into an *equivalent series circuit* composed of impedances in series. An equivalent series circuit is one which, as far as the terminals are concerned, acts identically to the original parallel circuit; the current through the circuit and the power dissipation of the resistive elements are the same for a given voltage at the specified frequency.

We can check the equivalent series circuit of figure 15 with respect to the original circuit by assuming that one volt a-c (at the frequency where the capacitive reactance in the parallel circuit is 4 ohms) is applied to the terminals of both the series and parallel circuits.

In the parallel circuit the current through the resistor will be $\frac{1}{6}$ ampere (0.166 amp) while the current through the capacitor will be $j \frac{1}{4}$ ampere ($+ j 0.25$ amp). The total current will be the sum of these two currents, or $0.166 + j 0.25$ amp. Adding these vectorially we obtain:

$$|I| = \sqrt{0.166^2 + 0.25^2} = \sqrt{0.09}$$

$$= 0.3 \text{ amp.}$$

The dissipation in the resistor will be $I^2 R = 1^2 / 6 = 0.166$ watts.

In the case of the equivalent series circuit the current will be:

$$|I| = \frac{E}{|Z|} = \frac{1}{3.33} = 0.3 \text{ amp}$$

And the dissipation in the resistor will be:

$$W = I^2 R = 0.3^2 \times 1.85$$

$$= 0.09 \times 1.85$$

$$= 0.166 \text{ watts}$$

So we see that the equivalent series circuit checks exactly with the original parallel circuit.

Parallel RLC Circuits In solving a more complicated circuit made up of more than two impedances in parallel we may elect to use either of two methods of solution. These methods are called the *admittance* method and the *assumed-voltage* method. However, the two methods are equivalent since both use the sum-of-reciprocals equation:

$$\frac{1}{Z_{\text{Total}}} = \frac{1}{Z_1} + \frac{1}{Z_2} + \frac{1}{Z_3} \dots \dots$$

In the admittance method we use the relation $Y = 1/Z$, where $Y = G + jB$; Y is called the *admittance*, defined above, G is the *conductance* or R/Z^2 and B is the *susceptance* or $-X/Z^2$. Then $Y_{\text{Total}} = 1/Z_{\text{Total}} = Y_1 + Y_2 + Y_3 \dots$. In the assumed-voltage method we multiply both sides of the equation above by E , the assumed voltage, and add the currents, as:

$$\frac{E}{Z_{\text{Total}}} = \frac{E}{Z_1} + \frac{E}{Z_2} + \frac{E}{Z_3} \dots = I_{z_1} + I_{z_2} + I_{z_3} \dots$$

Then the impedance of the parallel combination may be determined from the relation:

$$Z_{\text{Total}} = E / I_{z_{\text{Total}}}$$

A-C Voltage Dividers Voltage dividers for use with alternating current are quite similar to d-c voltage dividers.

However, since capacitors and inductors as well as resistors oppose the flow of a-c current, voltage dividers for alternating voltages may take any of the configurations shown in figure 16.

Since the impedances within each divider are of the same type, the output voltage is

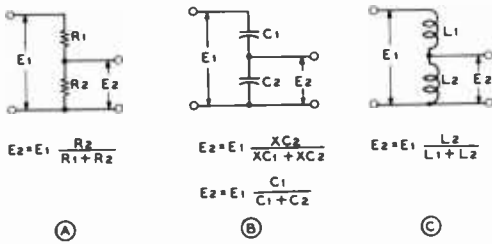

Figure 16

SIMPLE A-C VOLTAGE DIVIDERS

in phase with the input voltage. By using combinations of different types of impedances, the phase angle of the output may be shifted in relation to the input phase angle at the same time the amplitude is reduced. Several dividers of this type are shown in figure 17. Note that the ratio of output voltage is equal to the ratio of the output impedance to the total divider impedance. This relationship is true only if negligible current is drawn by a load on the output terminals.

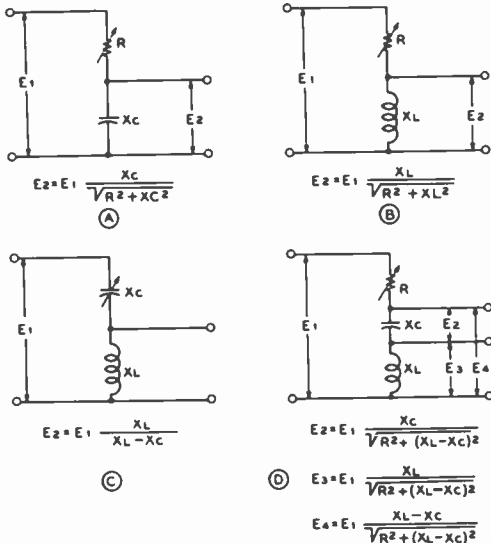

Figure 17

COMPLEX A-C VOLTAGE DIVIDERS

3-2 Resonant Circuits

A series circuit such as shown in figure 18 is said to be in *resonance* when the applied frequency is such that the capacitive reactance is exactly balanced by the inductive reactance. At this frequency the two reactances will cancel in their effects, and the impedance of the circuit will be at a minimum so that maximum current will flow. In fact, as shown in figure 19 the net impedance of a series circuit at resonance is equal to the resistance which remains in the circuit after the reactances have been cancelled.

Resonant Frequency Some resistance is always present in a circuit because it is possessed in some degree by both the inductor and the capacitor. If the frequency of the alternator E is varied from nearly zero to some high frequency, there will be one particular frequency at which the inductive reactance and capacitive reactance will be equal. This is known as the *resonant frequency*, and in a series circuit it is the frequency at which the circuit current will be a maximum. Such series-resonant circuits are chiefly used when it is desirable to allow a certain frequency to pass through the circuit (low impedance to this frequency), while at the same time the circuit is made to offer considerable opposition to currents of other frequencies.

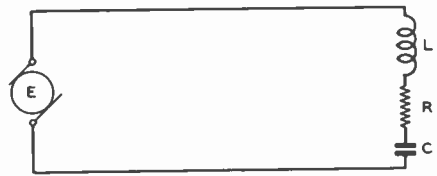

Figure 18

SERIES-RESONANT CIRCUIT

If the values of inductance and capacitance both are fixed, there will be only one resonant frequency.

If both the inductance and capacitance are made variable, the circuit may then be changed or *tuned*, so that a number of combinations of inductance and capacitance can resonate at the same frequency.

This can be more easily understood when one considers that inductive reactance and capacitive reactance change in opposite directions as the frequency is varied. For example, if the frequency were to remain constant and the values of inductance and capacitance were then changed, the following combinations would have equal reactance:

Frequency is constant at 60 Hz.

L is expressed in henrys.

C is expressed in microfarads (.00001 farad.)

L	X _L	C	X _C
.265	100	26.5	100
2.65	1000	2.65	1000
26.5	10,000	.265	10,000
265.00	100,000	.0265	100,000
2,650.00	1,000,000	.00265	1,000,000

Frequency of Resonance From the formula for resonance, $2\pi fL = 1/2\pi fC$, the resonant frequency is determined:

$$f = \frac{1}{2\pi \sqrt{LC}}$$

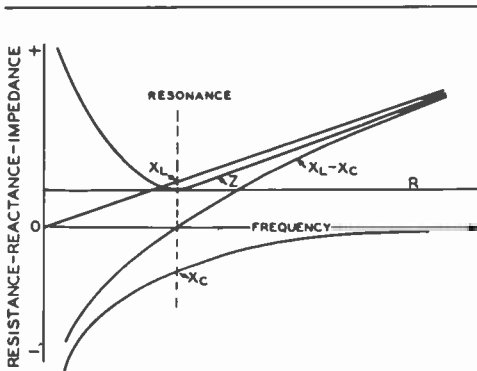

Figure 19

IMPEDANCE OF A SERIES-RESONANT CIRCUIT

Showing the variation in reactance of the separate elements and in the net impedance of a series resonant circuit (such as figure 18) with changing frequency. The vertical line is drawn at the point of resonance ($X_L - X_C = 0$) in the series circuit.

where,

f equals frequency in hertz,

L equals inductance in henrys,

C equals capacitance in farads.

It is more convenient to express L and C in smaller units, especially in making radio-frequency calculations; f can also be expressed in MHz or kHz. A very useful group of such formulas is:

$$f^2 = \frac{25,330}{LC} \text{ or } L = \frac{25,330}{f^2 C} \text{ or } C = \frac{25,330}{f^2 L}$$

where,

L equals inductance in microhenrys,

f equals frequency in MHz,

C equals capacitance in picofarads.

Impedance of Series Resonant Circuits The impedance across the terminals of a series-resonant circuit (figure 18) is:

$$Z = \sqrt{r^2 + (X_L - X_C)^2}$$

where,

Z equals impedance in ohms,

r equals resistance in ohms,

X_C equals capacitive reactance in ohms,

X_L equals inductive reactance in ohms.

From this equation, it can be seen that the impedance is equal to the vector sum of the circuit resistance and the difference between the two reactances. Since at the resonant frequency X_L equals X_C, the difference between them (figure 19) is zero, so that at resonance the impedance is simply equal to the resistance of the circuit; therefore, because the resistance of most normal radio-frequency circuits is of a very low order, the impedance is also low.

At frequencies higher and lower than the resonant frequency, the difference between the reactances will be a definite quantity and will add with the resistance to make the impedance higher and higher as the circuit is tuned off the resonant frequency.

If X_C should be greater than X_L, then the term (X_L - X_C) will give a negative number. However, when the difference is squared the product is always positive. This means that the smaller reactance is subtracted from the larger, regardless of whether it be

capacitive or inductive, and the difference is squared.

Current and Voltage in Series-Resonant Circuits Formulas for calculating currents and voltages in a series-resonant circuit are similar to

those of Ohm's Law.

$$I = \frac{E}{Z} \quad E = IZ$$

The complete equations are:

$$I = \frac{E}{\sqrt{r^2 + (X_L - X_C)^2}}$$

$$E = I \sqrt{r^2 + (X_L - X_C)^2}$$

Inspection of the above formulas will show the following to apply to series-resonant circuits: When the impedance is low, the current will be high; conversely, when the impedance is high, the current will be low.

Since it is known that the impedance will be very low at the resonant frequency, it follows that the current will be a maximum at this point. If a graph is plotted of the

current against the frequency either side of resonance, the resultant curve becomes what is known as a *resonance curve*. Such a curve is shown in figure 20, the frequency being plotted against *current* in the series-resonant circuit.

Several factors will have an effect on the shape of this resonance curve, of which resistance and L-to-C ratio are the important considerations. The lower curves in figure 20 show the effect of adding increasing values of resistance to the circuit. It will be seen that the peaks become less and less prominent as the resistance is increased; thus, it can be said that the *selectivity* of the circuit is thereby *decreased*. Selectivity in this case can be defined as the ability of a circuit to discriminate against frequencies adjacent to (both above and below) the resonant frequency.

Voltage Across Coil and Capacitor in Series Circuit Because the a-c or r-f voltage across a coil and capacitor is proportional

to the reactance (for a given current), the actual voltages across the coil and across the capacitor may be many times greater than the *terminal* voltage of the circuit. At resonance, the voltage across the coil (or the capacitor) is Q times the applied voltage. Since the Q (or *merit factor*) of a series circuit can be in the neighborhood of 100 or more, the voltage across the capacitor, for example, may be high enough to cause flashover, even though the applied voltage is of a value considerably below that at which the capacitor is rated.

Circuit Q — Sharpness of Resonance An extremely important property of a capacitor or an inductor is its *factor-of-merit*, more generally called its Q. It is this factor, Q, which primarily determines the sharpness of resonance of a tuned circuit. This factor can be expressed as the ratio of the reactance to the resistance, as follows:

$$Q = \frac{2\pi fL}{R}$$

where,

R equals total resistance.

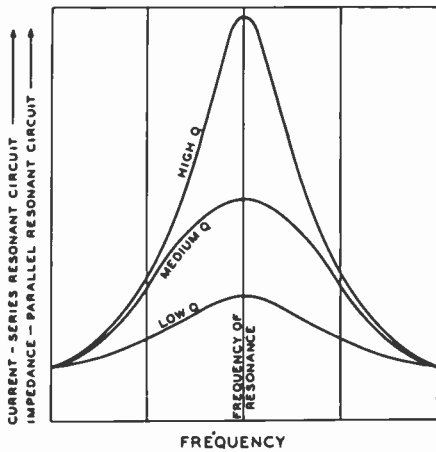

Figure 20

RESONANCE CURVE

owing the increase in impedance at resonance for a parallel-resonant circuit, and similarly, the increase in current at resonance for a series-resonant circuit. The sharpness of resonance is determined by the Q of the circuit, as illustrated by a comparison between the three curves.

Skin Effect The actual resistance in a wire or an inductor can be far greater than the d-c value when the coil is used in a radio-frequency circuit; this is because the current does not travel through the entire cross section of the conductor, but has a tendency to travel closer and closer to the surface of the wire as the frequency is increased. This is known as the *skin effect*.

The actual current carrying portion of the wire is decreased as a result of the skin effect so that the ratio of a-c to d-c resistance of the wire, called the *resistance ratio*, is increased. The resistance ratio of wires to be used at frequencies below about 500 kHz may be materially reduced through the use of *litz* wire. Litz wire, of the type commonly used to wind the coils of 455 — kHz i-f transformers, may consist of 3 to 10 strands of insulated wire, about No. 40 in size, with the individual strands connected together only at the ends of the coils.

Variation of Q with Frequency Examination of the equation for determining Q might

give rise to the thought that even though the resistance of an inductor increases with frequency, the inductive reactance does likewise, so that the Q might be a constant. Actually, however, it works out in practice that the Q of an inductor will reach a relatively broad maximum at some particular frequency. Hence, coils normally are designed in such a manner that the peak in their curve of Q versus frequency will occur at the normal operating frequency of the coil in the circuit for which it is designed.

The Q of a capacitor ordinarily is much higher than that of the best coil. Therefore, it usually is the merit of the coil that limits the over-all Q of the circuit.

At audio frequencies the core losses in an iron-core inductor greatly reduce the Q from the value that would be obtained simply by dividing the reactance by the resistance. Obviously the core losses also represent circuit resistance, just as though the loss occurred in the wire itself.

Parallel Resonance In radio circuits, parallel resonance (more correctly termed *antiresonance*) is more frequently encountered than series resonance; in fact, it is the basic foundation of receiver and

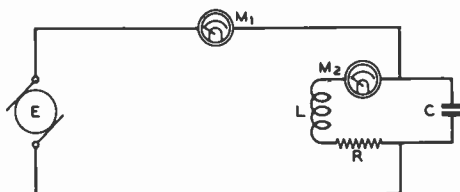

Figure 21

PARALLEL-RESONANT CIRCUIT

The inductance L and capacitance C comprise the reactive elements of the parallel-resonant (antiresonant) tank circuit, and the resistance R indicates the sum of the r-f resistance of the coil and capacitor, plus the resistance coupled into the circuit from the external load. In most cases the tuning capacitor has much lower r-f resistance than the coil and can therefore be ignored in comparison with the coil resistance and the coupled-in resistance. The instrument M_1 indicates the "line current" which keeps the circuit in a state of oscillation—this current is the same as the fundamental component of the plate current of a class-C amplifier which might be feeding the tank circuit. The instrument M_2 indicates the "tank current" which is equal to the line current multiplied by the operating Q of the tank circuit.

transmitter circuit operation. A circuit is shown in figure 21.

The "Tank" Circuit In this circuit, as contrasted with a circuit for series resonance, L (inductance) and C (capacitance) are connected in *parallel*, yet the *combination* can be considered to be in series with the remainder of the circuit. This combination of L and C , in conjunction with R , the resistance which is principally included in L , is sometimes called a *tank circuit* because it effectively functions as a storage tank when incorporated in vacuum-tube circuits.

Contrasted with series resonance, there are two kinds of current which must be considered in a parallel-resonant circuit: (1) the *line current*, as read on the indicating meter M_1 , (2) the *circulating current* which flows within the parallel LCR portion of the circuit. See figure 21.

At the resonant frequency, the line current (as read on the meter M_1) will drop to a very low value although the circulating current in the LC circuit may be quite large. It is interesting to note that the parallel-resonant circuit acts in a distinctly opposite manner to that of a series-resonant circuit,

in which the current is at a maximum and the impedance is minimum at resonance. It is for this reason that in a parallel-resonant circuit the principal consideration is one of impedance rather than current. It is also significant that the *impedance* curve for *parallel* circuits is very nearly identical to that of the *current* curve for *series* resonance. The impedance at resonance is expressed as:

$$Z = \frac{(2\pi fL)^2}{R}$$

where,

Z equals impedance in ohms,
 L equals inductance in henrys,
 f equals frequency in hertz,
 R equals resistance in ohms.

Or, impedance can be expressed as a function of Q as:

$$Z = 2\pi fLQ$$

showing that the impedance of a circuit is directly proportional to its effective Q at resonance.

The curves illustrated in figure 20 can be applied to parallel resonance. Reference to the curve will show that the effect of adding resistance to the circuit will result in both a broadening out and lowering of the peak of the curve. Since the voltage of the circuit is directly proportional to the impedance, and since it is this voltage that is applied to the grid of the vacuum tube in a detector or amplifier circuit, the impedance curve must have a sharp peak in order for the circuit to be *selective*. If the curve is broad-topped in shape, both the desired signal and the interfering signals at close proximity to resonance will give nearly equal voltages on the grid of the tube, and the circuit will then be *nonselective*; that is, it will tune broadly.

Effect of L/C Ratio in Parallel Circuits In order that the highest possible voltage can be developed across a parallel-resonant circuit, the impedance of this circuit must be very high. The impedance will be greater with conventional coils of limited Q when the ratio of inductance to capacitance is great, that is, when L is large as compared with C . When the resistance of the circuit is very low, X_L will equal X_C at

maximum impedance. There are innumerable ratios of L and C that will have *equal* reactance, at a given resonant frequency, exactly as in the case in a series-resonant circuit.

In practice, where a certain value of inductance is tuned by a variable capacitance over a fairly wide range in frequency, the L/C ratio will be small at the lowest-frequency end and large at the high-frequency end. The circuit, therefore, will have unequal gain and selectivity at the two ends of the band of frequencies which is being tuned. Increasing the Q of the circuit (lowering the resistance) will obviously increase *both* the selectivity and gain.

Circulating Tank Current at Resonance The Q of a circuit has a definite bearing on the circulating tank

current at resonance. This tank current is very nearly the value of the line current multiplied by the effective circuit Q . For example: an r-f line current of 0.050 ampere, with a circuit Q of 100, will give a circulating tank current of approximately 5 amperes. From this it can be seen that both the inductor and the connecting wires in a circuit with a high Q must be of very low resistance, particularly in the case of high-power transmitters, if heat losses are to be held to a minimum.

Because the voltage across the tank at resonance is determined by the Q , it is possible to develop very high peak voltages across a high- Q tank with but little line current.

Effect of Coupling on Impedance If a parallel-resonant circuit is coupled to another

circuit, such as an antenna output circuit, the impedance and the effective Q of the parallel circuit is decreased as the coupling becomes closer. The effect of closer (tighter) coupling is the same as though an actual resistance were added in series with the parallel tank circuit. The resistance thus coupled into the tank circuit can be considered as being *reflected* from the output or load circuit to the driver circuit.

The behavior of *coupled circuits* depends largely on the amount of coupling, as shown in figure 22. The coupled current in the

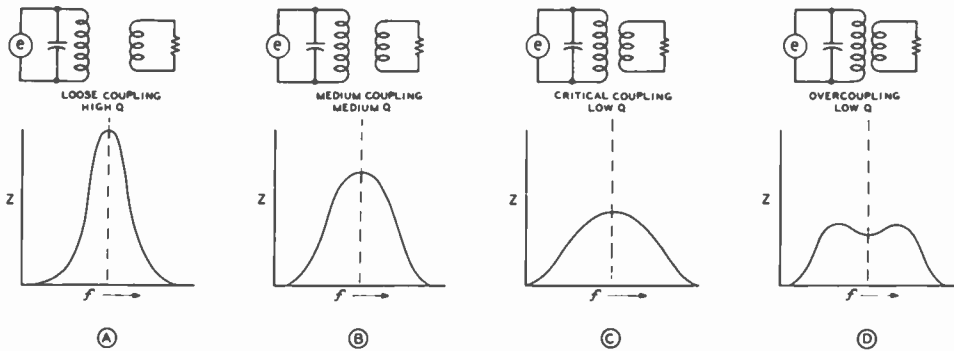

Figure 22
EFFECT OF COUPLING ON CIRCUIT IMPEDANCE AND Q

secondary circuit is small, varying with frequency, being maximum at the resonant frequency of the circuit. As the coupling is increased between the two circuits, the secondary resonance curve becomes broader and the resonant amplitude increases, until the reflected resistance is equal to the primary resistance. This point is called the *critical coupling point*. With greater coupling, the secondary resonance curve becomes broader and develops double resonance humps, which become more pronounced and farther apart in frequency as the coupling between the two circuits is increased.

Tank-Circuit Flywheel Effect When the plate circuit of a class-B or class-C operated tube is connected to a parallel-resonant circuit tuned to the same frequency as the exciting voltage for the amplifier, the plate current serves to maintain this L/C circuit in a state of oscillation.

The plate current is supplied in short pulses which do not begin to resemble a sine wave, even though the grid may be excited by a sine-wave voltage. These spurts of plate current are converted into a sine wave in the plate tank circuit by virtue of the Q or *flywheel effect* of the tank.

If a tank did not have some resistance losses, it would, when given a "kick" with a single pulse, continue to oscillate indefinitely. With a moderate amount of resistance or "friction" in the circuit the tank will still have inertia, and continue to oscillate with decreasing amplitude for a time after being given a "kick." With such a circuit, almost pure sine-wave voltage will be developed

across the tank circuit even though power is supplied to the tank in short pulses or spurts, so long as the spurts are evenly spaced with respect to time and have a frequency that is the same as the resonant frequency of the tank.

Another way to visualize the action of the tank is to recall that a resonant tank with moderate Q will discriminate strongly against harmonics of the resonant frequency. The distorted plate current pulse in a class-C amplifier contains not only the fundamental frequency (that of the grid excitation voltage) but also higher harmonics. As the tank offers low impedance to the harmonics and high impedance to the fundamental (being resonant to the latter), only the fundamental — a sine-wave voltage — appears across the tank circuit in substantial magnitude.

Loaded and Unloaded Q Confusion sometimes exists as to the relationship between the unloaded and the loaded Q of the tank circuit in the plate of an r-f power amplifier. In the normal case the loaded Q of the tank circuit is determined by such factors as the operating conditions of the amplifier, bandwidth of the signal to be emitted, permissible level of harmonic radiation, and such factors. The normal value of *loaded Q* for an r-f amplifier used for communications service is from perhaps 6 to 20. The *unloaded Q* of the tank circuit determines the efficiency of the output circuit and is determined by the losses in the tank coil, its leads and plugs and jacks if any, and by the losses in the tank capacitor

which ordinarily are very low. The unloaded Q of a good quality large diameter tank coil in the high-frequency range may be as high as 500 to 800, and values greater than 300 are quite common.

Tank-Circuit Efficiency Since the unloaded Q of a tank circuit is determined by the minimum losses in the tank, while the loaded Q is determined by useful loading of the tank circuit from the external load in addition to the internal losses in the tank circuit, the relationship between the two Q values determines the operating efficiency of the tank circuit. Expressed in the form of an equation, the loaded efficiency of a tank circuit is:

$$\text{Tank efficiency} = \left(1 - \frac{Q_0}{Q_1}\right) \times 100$$

where,

Q_0 equals unloaded Q of the tank circuit,
 Q_1 equals loaded Q of the tank circuit.

As an example, if the unloaded Q of the tank circuit for a class-C r-f power amplifier is 400, and the external load is coupled to the tank circuit by an amount such that the loaded Q is 20, the tank-circuit efficiency will be: $\text{eff.} = (1 - 20/400) \times 100$, or $(1 - 0.05) \times 100$, or 95 per cent. Hence 5 per cent of the power output of the class-C amplifier will be lost as heat in the tank circuit and the remaining 95 per cent will be delivered to the load.

3-3 Nonsinusoidal Waves and Transients

Pure sine waves, discussed previously, are basic wave shapes. Waves of many different and complex shapes are used in electronics, particularly square waves, sawtooth waves, and peaked waves.

Wave Composition Any periodic wave (one that repeats itself in definite time intervals) is composed of sine waves of different frequencies and amplitudes, added together. The sine wave which has the same frequency as the complex, periodic wave is called the *fundamental*. The frequencies higher than the fundamental are

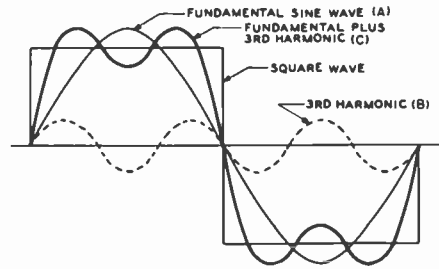

Figure 23

COMPOSITE WAVE—FUNDAMENTAL PLUS THIRD HARMONIC

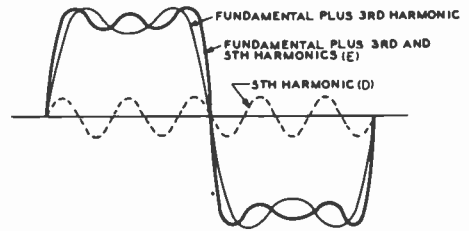

Figure 24

THIRD-HARMONIC WAVE PLUS FIFTH HARMONIC

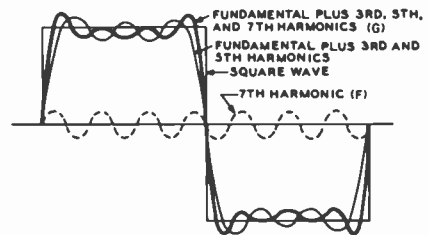

Figure 25

RESULTANT WAVE, COMPOSED OF FUNDAMENTAL, THIRD, FIFTH, AND SEVENTH HARMONICS

called *harmonics*, and are always a whole number of times higher than the fundamental. For example, the frequency twice as high as the fundamental is called the *second harmonic*.

The Square Wave Figure 23 compares a square wave (A) of the same frequency. If another

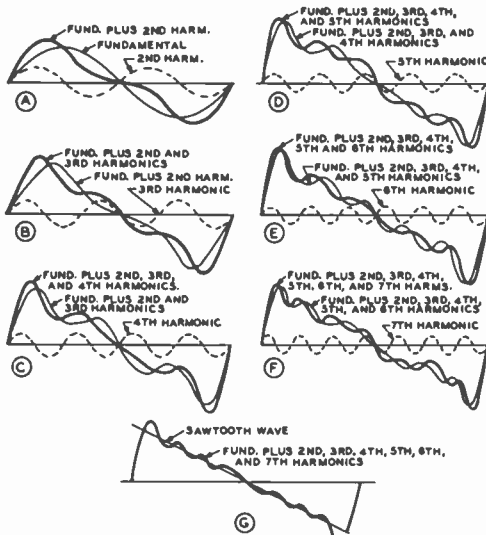

Figure 26

COMPOSITION OF A SAWTOOTH WAVE

sine wave (B) of smaller amplitude, but three times the frequency of A, called the third harmonic, is added to A, the resultant wave (C) more nearly approaches the desired square wave.

This resultant curve (figure 24) is added to a fifth-harmonic curve (D), and the sides of the resulting curve (E) are steeper than before. This new curve is shown in figure 25 after a 7th-harmonic component has been added to it, making the sides of the composite wave even steeper. Addition of more higher odd harmonics will bring the resultant wave nearer and nearer to the desired square-wave shape. The square wave will be achieved if an infinite number of odd harmonics are added to the original sine wave.

The Sawtooth Wave In the same fashion, a *sawtooth wave* is made up of different sine waves (figure 26). The addition of all harmonics, odd and even, produces the sawtooth waveform.

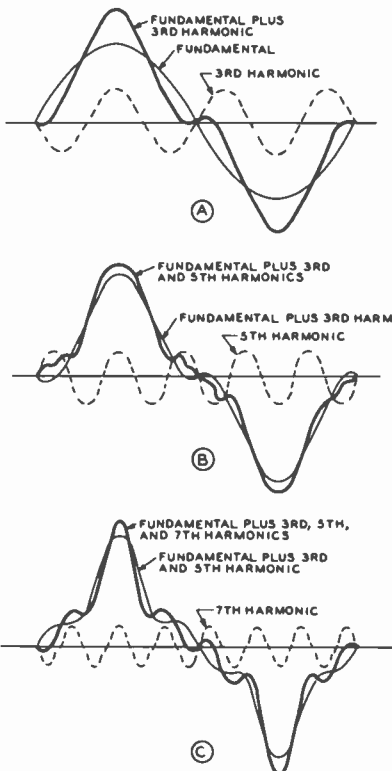

Figure 27

COMPOSITION OF A PEAKED WAVE

The Peaked Wave Figure 27 shows the composition of a *peaked wave*. Note how the addition of each successive harmonic makes the peak of the resultant higher, and the sides steeper.

Other Waveforms The three preceding examples show how a complex periodic wave is composed of a fundamental wave and different harmonics. The shape of the resultant wave depends on the harmonics that are added, their relative amplitudes, and relative phase relationships. In general, the steeper the sides of the waveform, the more harmonics it contains.

A-C Transient Circuits If an a-c voltage is substituted for the d-c input voltage in the RC transient circuits discussed in Chapter 2, the same principles may be applied in the analysis of the transient behavior. An RC coupling circuit is designed to have a long time constant with respect to the lowest frequency it must pass. Such a circuit is shown in figure 28. If a nonsinusoidal voltage is to be passed unchanged through the coupling circuit, the time constant must be long with respect to the period of the lowest frequency contained in the voltage wave.

RC Differentiator and Integrator An RC voltage divider that is designed to distort the input waveform is known as a *differentiator* or *integrator*, depending on the locations of the output taps. The output from a differentiator is taken across the resistance, while the output from an integrator is taken across the capacitor. Such circuits will change the shape of any complex a-c waveform that is impressed on them. This distortion is a function of the value of the time constant of the circuit as compared to the period of the waveform. Neither a differentiator nor an integrator can change the shape of a pure sine wave, they will merely shift the phase of the wave (figure 29). The differentiator output is a sine wave leading the input wave, and the integrator output is a sine wave which lags the input wave. The sum of the two outputs at any instant equals the instantaneous input voltage.

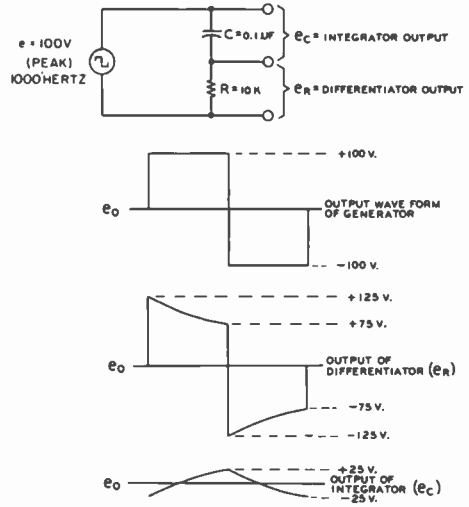

Figure 30

RC DIFFERENTIATOR AND INTEGRATOR ACTION ON A SQUARE WAVE

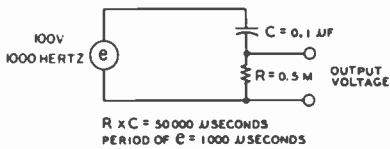

Figure 28

RC COUPLING CIRCUIT WITH LONG TIME CONSTANT

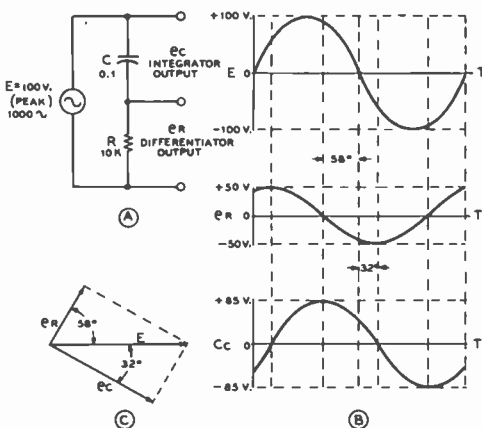

Figure 29

RC DIFFERENTIATOR AND INTEGRATOR ACTION ON A SINE WAVE

Square-Wave Input If a square-wave voltage is impressed on the circuit of figure 30, a square-wave voltage output may be obtained across the integrating capacitor if the time constant of the circuit allows the capacitor to become fully charged. In this particular case, the capacitor never fully charges, and as a result the output of the integrator has a smaller amplitude than the input. The differentiator output has a maximum value greater than the input amplitude, since the voltage left on the capacitor from the previous half wave will add to the input voltage. Such a circuit, when used as a differentiator, is often called a *peaker*. Peaks of twice the input amplitude may be produced.

Sawtooth-Wave Input If a back-to-back sawtooth voltage is applied to an RC circuit having a time constant one-sixth the period of the input voltage, the result is shown in figure 31. The capacitor voltage will closely follow the input voltage, if the time constant is short, and the integrator output closely resembles the input. The amplitude is slightly reduced and there is a slight phase lag. Since the voltage across the capacitor is increasing at a constant rate, the charging and discharg-

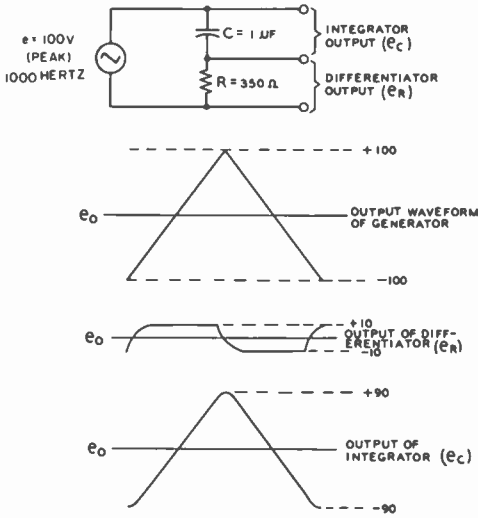

Figure 31

RC DIFFERENTIATOR AND INTEGRATOR ACTION ON A SAWTOOTH WAVE

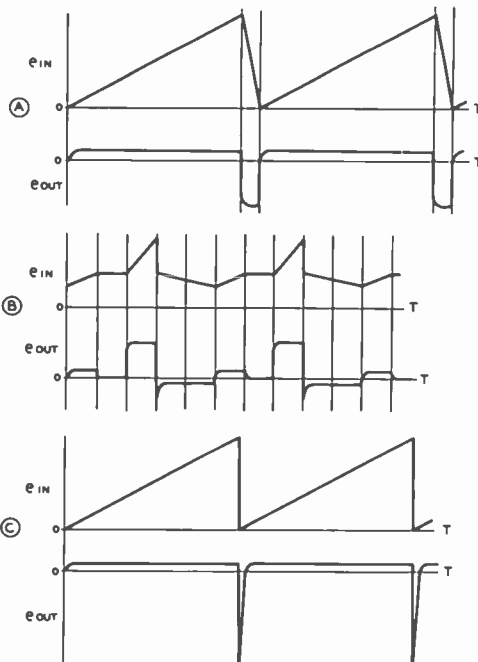

Figure 32

Differentiator outputs of short-time-constant RC circuits for various input voltage wave-shapes. The output voltage is proportional to the rate of change of the input voltage.

ing current is constant. The output voltage of the differentiator, therefore, is constant during each half of the sawtooth input.

Miscellaneous Inputs Various voltage waveforms other than those represented here may be applied to short-time-constant RC circuits for the purpose of producing across the resistor an output voltage with an amplitude *proportional to the rate of change* of the input signal. The shorter the RC time constant is made with respect to the period of the input wave, the more nearly the voltage across the capacitor conforms to the input voltage. Thus, the differentiator output becomes of particular importance in very short-time-constant RC circuits. Differentiator outputs for various types of input waves are shown in figure 32.

Square-Wave Test for Audio Equipment The application of a square-wave input signal to audio equipment, and the observation of the reproduced output signal on an oscilloscope will provide a quick and accurate check of the over-all operation of audio equipment.

Low-frequency and high-frequency response, as well as transient response can be examined easily.

If the amplifier is deficient in low-frequency response, the flat top of the square wave will be canted, as in figure 33. If the high-frequency response is inferior, the rise time of the output wave will be retarded (figure 34).

An amplifier with a limited high- and low-frequency response will turn the square wave into the approximation of a sawtooth wave (figure 35).

3-4 Transformers

When two coils are placed in such inductive relation to each other that the lines of force from one cut across the turns of the other inducing a current, the combination can be called a *transformer*. The name is derived from the fact that energy is transformed from one winding to another. The inductance in which the original flux is produced is called the *primary*; the inductance which *receives* the induced current is

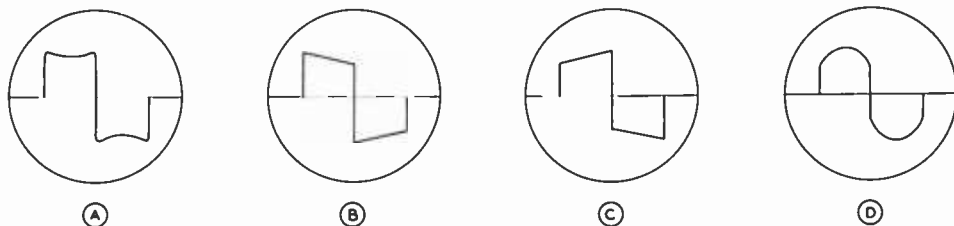

Figure 33

Amplifier deficient in low-frequency response will distort square wave applied to the input circuit, as shown. A 60-Hz square wave may be used.

- A:** Drop in gain at low frequencies
B: Leading phase shift at low frequencies
C: Lagging phase shift at low frequencies
D: Accentuated low-frequency gain

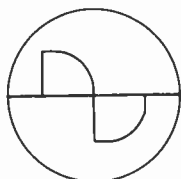

Figure 34

Output waveshape of amplifier having deficiency in high-frequency response. Tested with 10-kHz square wave.

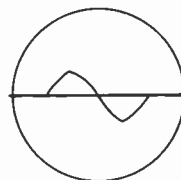

Figure 35

Output waveshape of amplifier having limited low-frequency and high-frequency response. Tested with 1 kHz square wave.

called the *secondary*. In a radio-receiver power transformer, for example, the coil through which the 120-volt a.c. passes is the *primary*, and the coil from which a higher or lower voltage than the a-c line potential is obtained is the *secondary*.

Transformers can have either air or magnetic cores, depending on the frequencies at which they are to be operated. The reader should thoroughly impress on his mind the fact that current can be transferred from one circuit to another *only* if the primary current is changing or alternating. From this it can be seen that a power transformer cannot possibly function as such when the primary is supplied with nonpulsating d-c.

A power transformer usually has a magnetic core which consists of laminations of iron, built up into a square or rectangular form, with a center opening or window. The secondary windings may be several in number, each perhaps delivering a different voltage. The secondary voltages will be proportional to the turns ratio and the primary voltage.

Types of Transformers Transformers are used in alternating-current circuits to transfer power at one voltage and impedance to another circuit at another voltage and impedance. There are three main classifications of transformers: those made for use in power-frequency circuits, those made for audio-frequency applications, and those made for radio frequencies.

The Transformation Ratio In a perfect transformer all the magnetic flux lines produced by the primary winding link every turn of the secondary winding. For such a transformer, the ratio of the primary and secondary voltages is exactly the same as the ratio of the number of turns in the two windings:

$$\frac{N_P}{N_S} = \frac{E_P}{E_S}$$

where,

N_P equals number of turns in the primary,
 N_S equals number of turns in the secondary,

E_P equals voltage across the primary,
 E_S equals voltage across the secondary.

In practice, the transformation ratio of a transformer is somewhat less than the turns ratio, since unity coupling does not exist between the primary and secondary windings.

Ampere Turns (NI) The current that flows in the secondary winding as a result of the induced voltage must produce a flux which exactly equals the primary flux. The magnetizing force of a coil is expressed as the product of the number of turns in the coil times the current flowing in it:

$$N_P \times I_P = N_S \times I_S, \text{ or } \frac{N_P}{N_S} = \frac{I_S}{I_P}$$

where,

I_P equals primary current,
 I_S equals secondary current.

It can be seen from this expression that when the voltage is stepped up, the current is stepped down, and vice versa.

Leakage Reactance Since unity coupling does not exist in a practical transformer, part of the flux passing from the primary circuit to the secondary circuit follows a magnetic circuit acted on by the primary only. The same is true of the secondary flux. These leakage fluxes cause *leakage reactance* in the transformer, and tend to cause the transformer to have poor voltage regulation. To reduce such leakage reactance, the primary and secondary windings should be in close proximity to each other. The more expensive transformers have interleaved windings to reduce inherent leakage reactance.

Impedance Transformation In the ideal transformer, the impedance of the secondary load is reflected back into the primary winding in the following relationship:

$$Z_P = N^2 Z_S, \text{ or } N = \sqrt{Z_P/Z_S}$$

where,

Z_P equals reflected primary impedance,
 N equals turns ratio of transformer,
 Z_S equals impedance of secondary load.

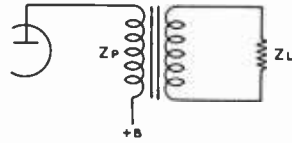

Figure 36

IMPEDANCE-MATCHING TRANSFORMER

The reflected impedance Z_p varies directly in proportion to the secondary load Z_L and directly in proportion to the square of the primary-to-secondary turns ratio.

Thus any specific load connected to the secondary terminals of the transformer will be transformed to a different specific value appearing across the primary terminals of the transformer. By the proper choice of turns ratio, any reasonable value of secondary load impedance may be "reflected" into the primary winding of the transformer to produce the desired transformer primary impedance. The phase angle of the primary "reflected" impedance will be the same as the phase angle of the load impedance. A capacitive secondary load will be presented to the transformer source as a capacitance, a resistive load will present a resistive "reflection" to the primary source. Thus the primary source "sees" a transformer load entirely dependent on the secondary load impedance and the turns ratio of the transformer (figure 36).

The Auto-transformer The type of transformer in figure 37, when wound with heavy wire over an iron core, is a common device in primary power circuits for

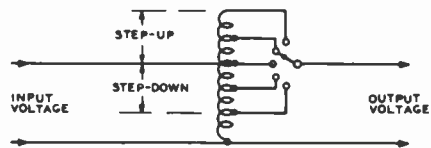

Figure 37

THE AUTOTRANSFORMER

Schematic diagram of an autotransformer showing the method of connecting it to the line and to the load. When only a small amount of step up or step down is required, the autotransformer may be much smaller physically than would be a transformer with a separate secondary winding. Continuously variable autotransformers (Variac and Powerstat) are widely used commercially.

the purpose of increasing or decreasing the line voltage. In effect, it is merely a continuous winding with taps taken at various points along the winding, the input voltage being applied to the bottom and also to one tap on the winding. If the output is taken from this same tap, the voltage ratio will be 1 to 1; i.e., the input voltage will be the same as the output voltage. On the other hand, if the output tap is moved down toward the common terminal, there will be a stepdown in the turns ratio with a consequent stepdown in voltage. The initial setting of the middle input tap is chosen so that the number of turns will have sufficient reactance to keep the no-load primary current at a reasonable low value.

3-5 Electric Filters

There are many applications where it is desirable to pass a d-c component without passing a superimposed a-c component, or to pass all frequencies above or below a certain frequency while rejecting or attenuating all others, or to pass only a certain band or bands of frequencies while attenuating all others.

All of these things can be done by suitable combinations of inductance, capacitance, and resistance. However, as whole books have been devoted to nothing but *electric filters*, it can be appreciated that it is possible only to touch on them superficially in a general-coverage book.

Filter Operation A filter acts by virtue of its property of offering very high impedance to the undesired frequencies, while offering but little impedance to the desired frequencies. This will also apply to d. c. with a superimposed a-c component, as d. c. can be considered as an alternating current of zero frequency so far as filter discussion goes.

Basic Filters Filters are divided into four classes, descriptive of the frequency bands which they are designed to transmit: high-pass, low-pass, bandpass, and band-elimination. Each of these classes of filters is made up of elementary filter sections called *L sections* which consist of a series element (Z_A) and a parallel element (Z_B) as

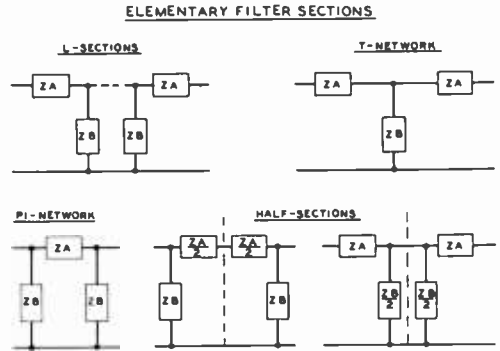

Figure 38

Complex filters may be made up from these basic filter sections.

illustrated in figure 38. A definite number of *L* sections may be combined into basic filter sections, called *T networks* or π networks, also shown in figure 38. Both the *T* and π networks may be divided in two to form *half-sections*.

Filter Sections The most common filter section is one in which the two impedances Z_A and Z_B are so related that their arithmetical product is a constant: $Z_A \times Z_B = k^2$ at all frequencies. This type of filter section is called a *constant- k section*.

A section having a sharper cutoff frequency than a constant- k section, but less attenuation at frequencies far removed from cutoff is the *m-derived section*, so called because the shunt or series element is resonated with a reactance of the opposite sign. If the complementary reactance is added to the series arm, the section is said to be *shunt derived*; if added to the shunt arm, *series derived*. Each impedance of the *m*-derived section is related to a corresponding impedance in the constant- k section by some factor which is a function of the constant m . In turn, m is a function of the ratio between the cutoff frequency and the frequency of infinite attenuation, and will have some value between zero and one. As the value of m approaches zero, the sharpness of cutoff increases, but the less will be the attenuation at several times cutoff frequency. A value of 0.6 may be used for m in most applications. The "notch" frequency is determined by the resonant frequency of

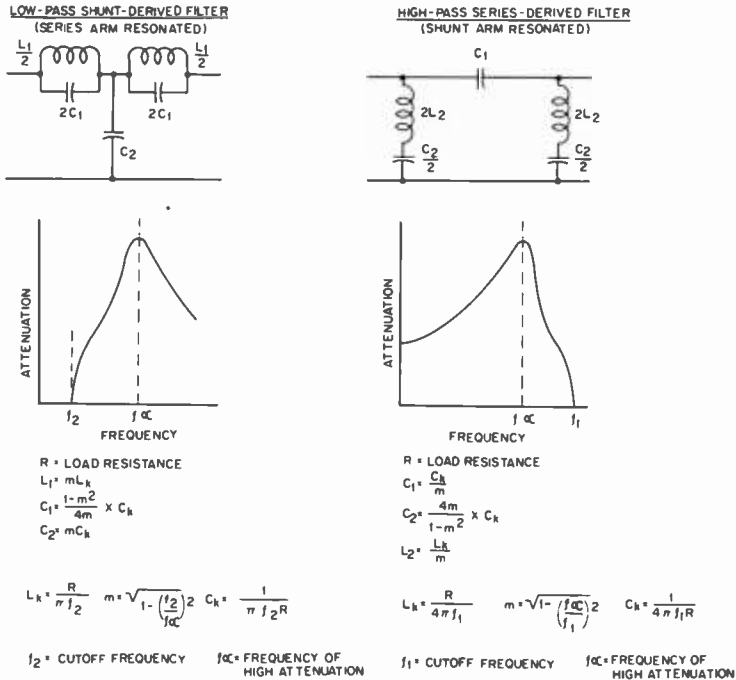

Figure 39

TYPICAL LOW-PASS AND HIGH-PASS FILTERS, ILLUSTRATING SHUNT AND SERIES DERIVATIONS

the tuned filter element. The amount of attenuation obtained at the "notch" when a derived section is used is determined by the effective *Q* of the resonant arm (figure 39).

Filter Assembly Constant-*k* sections and *m*-derived sections may be cascaded to obtain the combined characteristics of sharp cutoff and good remote frequency attenuation. Such a filter is known as a *composite* filter. The amount of attenuation will depend on the number of filter sections used, and the shape of the transmission curve depends on the type of filter sections used. All filters have some *insertion loss*. This attenuation is usually uniform to all frequencies within the passband. The insertion loss varies with the type of filter, the *Q* of the components, and the type of termination employed.

Filter Design Techniques Electric wave filters have long been used in some amateur stations in the audio channel to reduce the transmission of unwanted high frequencies and hence to reduce the bandwidth occupied by a radiophone signal. The effectiveness of a properly designed and properly used filter circuit in reducing QRM and sideband splatter should not be underestimated.

In recent years, high-frequency filters have become commonplace in TVI reduction. High-pass type filters are placed before the input stage of television receivers to reject the fundamental signal of low-frequency transmitters. Low-pass filters are used in the output circuits of low-frequency transmitters to prevent harmonics of the transmitter from being radiated in the television channels.

The chart of figure 40 gives design data and procedure on the π section type of

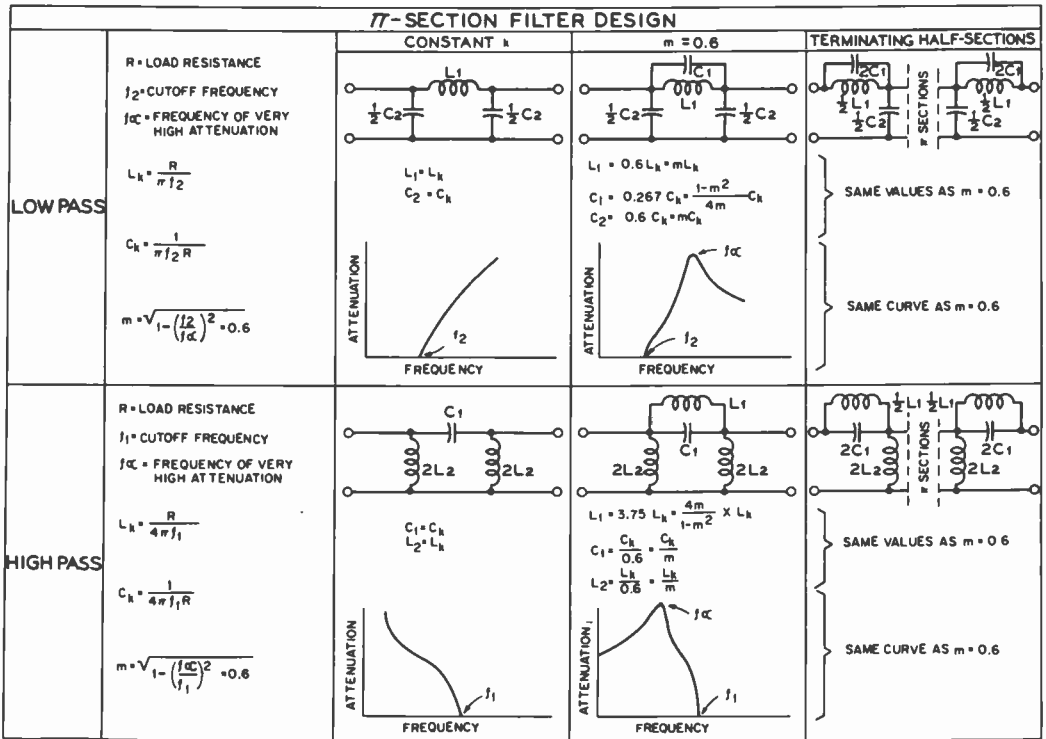

Figure 40

Through the use of the curves and equations which accompany the diagrams in the illustration above it is possible to determine the correct values of inductance and capacitance for the usual types of pi-section filters.

filter. The *m*-derived sections with an *m* of 0.6 will be found to be most satisfactory as the input section (or half-section) of the usual filter since the input impedance of such a section is most constant over the passband of the filter section.

Simple filters may use either *L*, *T*, or π sections. Since the π section is the more commonly used type, figure 40 gives design data and characteristics for this type of filter.

The image-parameter technique of filter design outlined in this section is being superseded by modern network synthesis, which takes advantage of the digital computer as a tool for multisection filter design. Filters designed by this new technique provide superior performance with less components than equivalent filters designed by the image-parameter scheme. Design tables for synthesis systems may be found in *Simplified Modern*

Filter Design by Geffe, published by John F. Rider Publisher, Inc., New York.

3-6 Low-Pass Filter Nomographs

The Constant-K Filter The low-pass constant-*k* filter has a passband from d.c. to the cutoff frequency (f_c). Beyond this frequency, the signal is attenuated as shown in figure 41.

Pi and *T* configurations for constant-*k* filters are shown in the illustration, with appropriate design formulas. The nomograph (#1 of figure 42) provides a graphical solution to these equations. The values of *L* and *C* can be determined by aligning a straight-edge from f_c on the left-hand scale to *R*(*L*) or *R*(*C*), respectively, on the right-

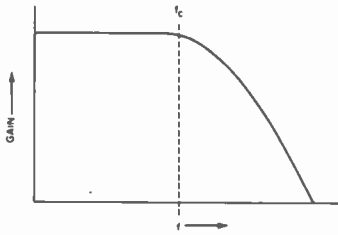

Figure 41

CONSTANT-K FILTER AND LOW-FREQUENCY BANDPASS

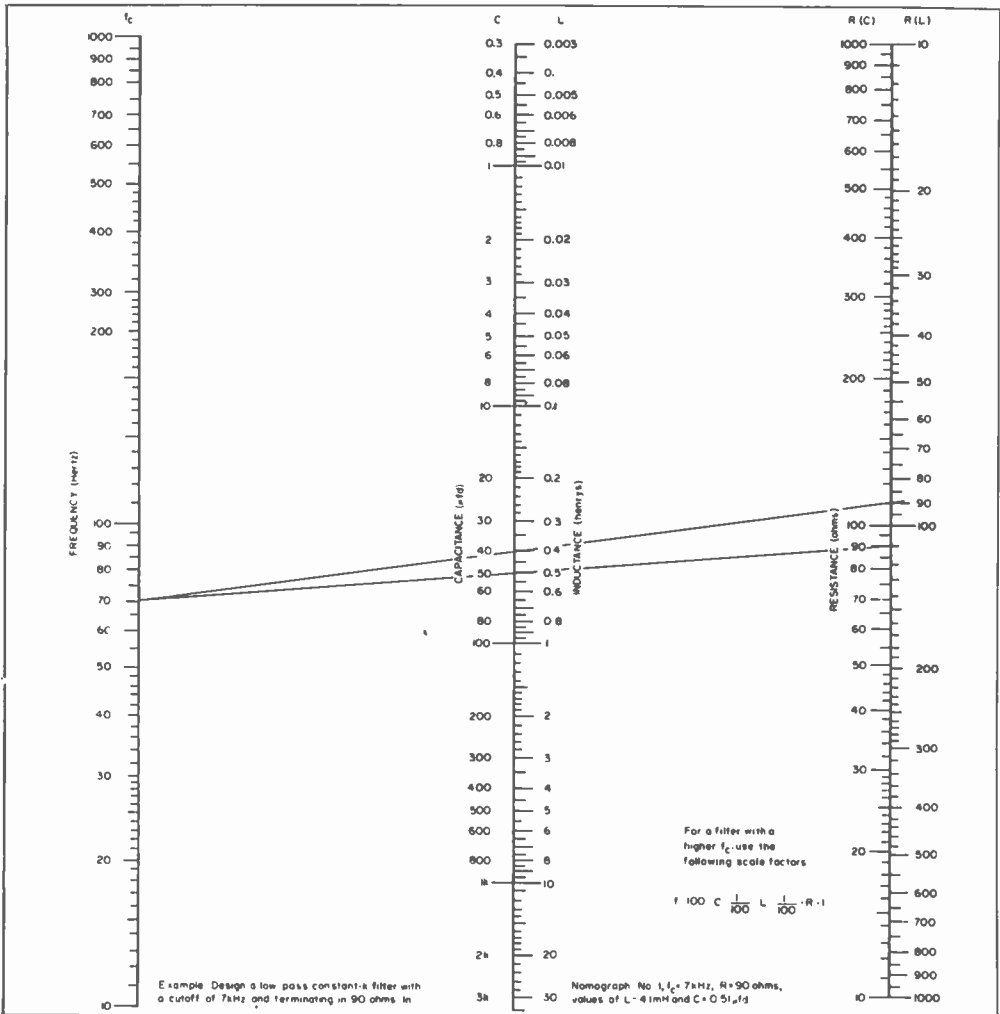
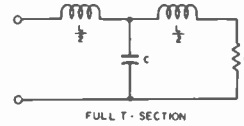
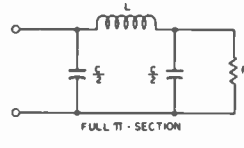

Figure 42

NOMOGRAPH #1, CONSTANT-K FILTER

The filter termination value (R) is used on separate scales (right-hand) for determination of C and L. An example is shown for R = 90 ohms.

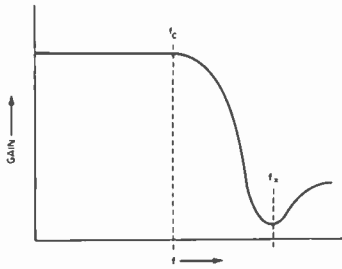
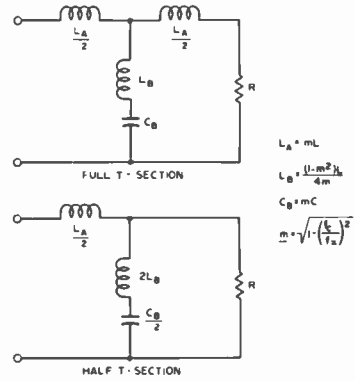

Figure 43

SERIES *m*-DERIVED FILTER AND LOW-FREQUENCY BANDPASS



hand scale. The values of L and C are found where the straightedge intersects the center scales. (Nomograph by Applebaum, reprinted with permission from the March, 1967 issue of *EDN Magazine*, Rogers Publishing Co., Englewood, Colo.)

The **Series *m*-Derived Filter** The low-pass, *m*-derived filter has a passband from d.c. to the cutoff frequency, f_c . Beyond this frequency, the signal is attenuated considerably to f_∞ , as shown in figure 43.

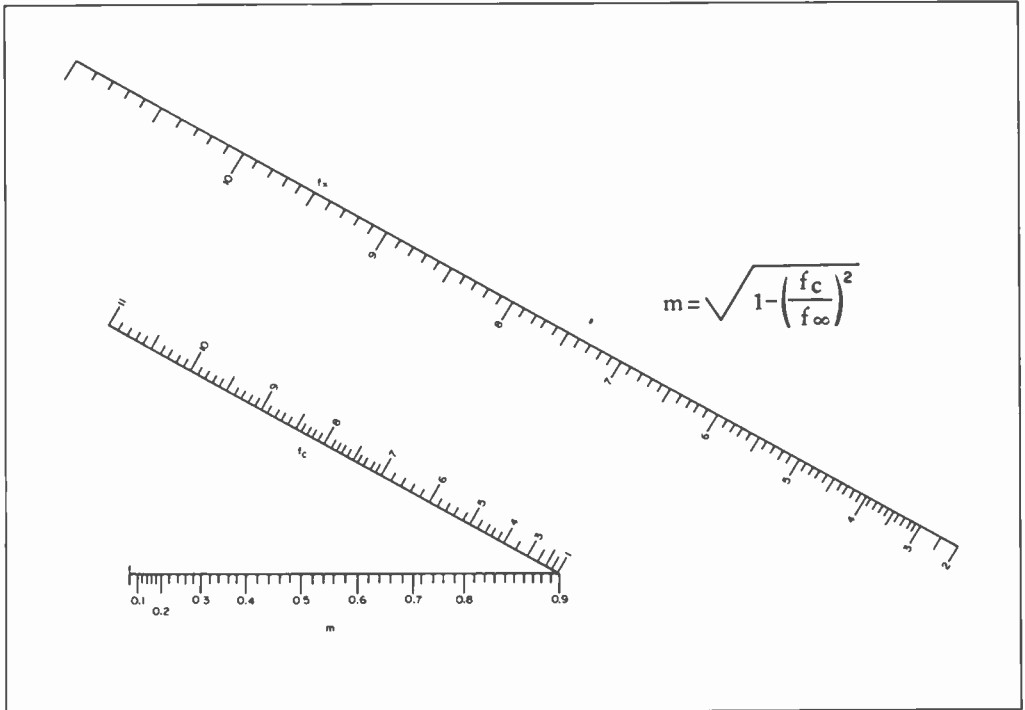

Figure 44

NOMOGRAPH #2. FILTER CONSTANT m IS DETERMINED FROM f_∞ AND f_c .

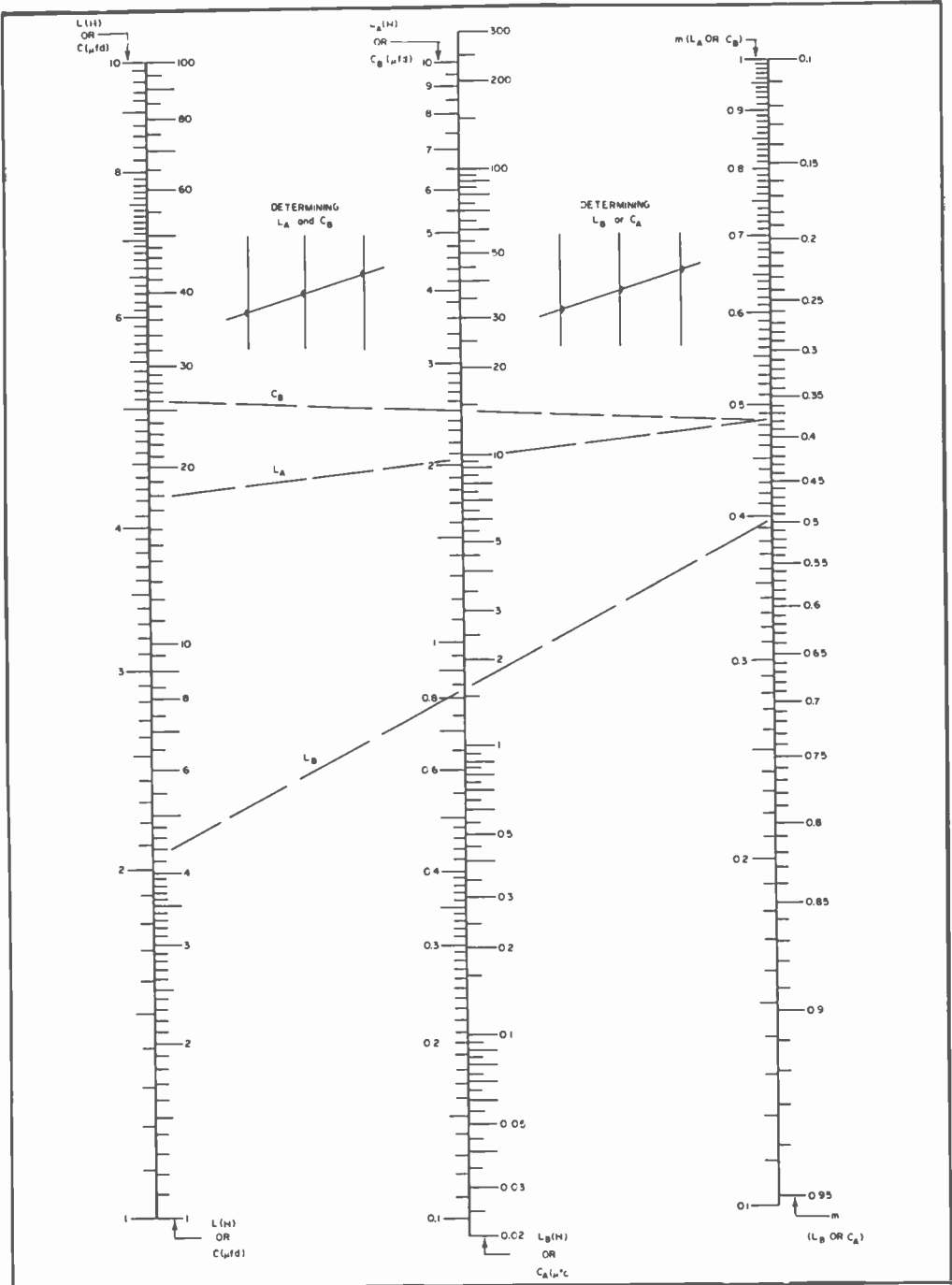

Figure 45

NOMOGRAPH #3. L_A AND C_B ARE DETERMINED USING L AND C (NOMOGRAPH #1) AND m (NOMOGRAPH #2.) ALL NUMBERS ARE FOUND WITH LEFT SIDE OF SCALES. L_B AND C_A ARE DETERMINED IN THE SAME MANNER, USING RIGHT SIDE OF SCALES.

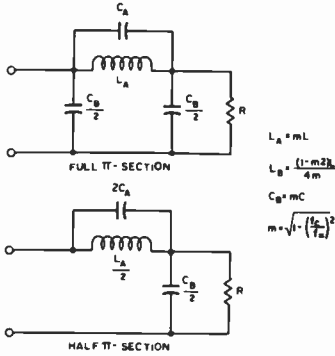

Figure 46

SHUNT *m*-DERIVED FILTER PI SECTIONS

The *T* section configuration used in series *m*-derived filters is shown in the nomograph of figure 43, with the appropriate design formulas. The correct value of *m* is found by the use of nomograph # 2 of figure 44. No units are given for *f_c* and *f_∞* since any frequency may be used provided that both scales use the same units. The value of *m* is determined by aligning a straightedge from the value of *f_∞* on its scale through the value of *f_c* on its scale. The value of *m* is found where the straightedge intersects the horizontal *m* scale.

The values of filter components *L_A*, *L_B*, and *C_B* are found with the aid of nomograph #3 of figure 45. Note that *L_A*, and *C_B* are found by using the left-hand scales, and *L_B* and *C_A* are found by using the right-hand scales.

By extending a straightedge from either *L* or *C* to the value of *m* (as found in figure 44) on their appropriate scales, *L_A*, *L_B*, and *C_B* are found where this line intersects the center scale. Any units may be used for *L* or *C* provided the same units are used for *C_B* or *L_A* and *L_B*, respectively. (*Nomo-*

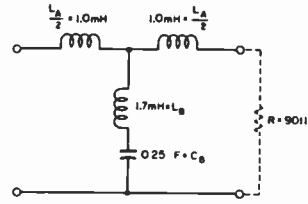

Figure 47

SERIES *m*-DERIVED FILTER DESIGNED FOR *f_c* = 7 kHz, *f_∞* = 8 kHz AND *R* = 90 OHMS

graph by Applebaum, reprinted with permission from the April, 1967 issue of EDN magazine, Rogers Publishing Co., Englewood, Colo.)

The Shunt, *m*-Derived Filter The pi section for the shunt, *m*-derived filter is shown in figure 46, using the nomenclature shown. The values of these components are found by using nomographs #2 and #3 of figures 44 and 45, just as with the series, *m*-derived filter design.

Example: Design a low-pass, series *m*-derived filter with a cutoff frequency of 7 kHz, a maximum attenuation at 8 kHz, and terminating in 90 ohms. Using the nomograph of figure 44, *m* is determined to be 0.485.

On the nomograph (#1 of figure 41) using *f_c* = 7 kHz and *R* = 90 on both *R(C)* and *R(L)* scales, the value of *L* and *C* are determined to be: *L*₂ = 0.0042 henry and *C*₂ = 0.51 μfd. Therefore, on nomograph #3 of figure 45, *L_A* = 0.002 henry (2 mH), *C_B* = 0.25 μfd and *L_B* = 0.0017 henry (1.7 mH). The final filter design is shown in figure 47.

Vacuum-Tube Principles

In the previous chapters we have seen the manner in which an electric current flows through a metallic conductor as a result of an electron drift. This drift, which takes place when there is a difference in potential between the ends of the metallic conductor, is in addition to the normal random electron motion between the molecules of the conductor.

The electron may be considered as a minute negatively charged particle, having a mass of 9×10^{-28} gram, and a charge of 1.59×10^{-19} coulomb. Electrons are always identical, regardless of the source from which they are obtained.

An electric current can be caused to flow through other media than a metallic conductor. One such medium is an ionized solution, such as the sulfuric acid electrolyte in a storage battery. This type of current flow is called *electrolytic conduction*. Further, it was shown at about the turn of the century that an electric current can be carried by a stream of free electrons in an evacuated chamber. The flow of a current in such a manner is said to take place by *electronic conduction*. The study of electron tubes (also called vacuum tubes, or valves) is actually the study of the control and use of electronic currents within an evacuated or partially evacuated chamber.

Since the current flow in an electron tube takes place in an evacuated chamber, there must be located within the enclosure both a source of electrons and a collector for the

electrons which have been emitted. The electron source is called the *cathode*, and the electron collector is usually called the *anode*. Some external source of energy must be applied to the cathode in order to impart sufficient velocity to the electrons within the cathode material to enable them to overcome the surface forces and thus escape into the surrounding medium. In the usual types of electron tubes the cathode energy is applied in the form of heat; electron emission from a heated cathode is called *thermionic emission*. In another common type of electron tube, the photoelectric cell, energy in the form of light is applied to the cathode to cause *photoelectric emission*.

4-1 Thermionic Emission

Electron Emission Emission of electrons from the cathode of a thermionic electron tube takes place when the cathode of the tube is heated to a temperature sufficiently high that the free electrons in the emitter have sufficient velocity to overcome the restraining forces at the surface of the material. These surface forces vary greatly with different materials. Hence different types of cathodes must be raised to different temperatures to obtain adequate quantities of electron emission. The several types of emitters found in common types of transmitting and receiving tubes will be described in the following paragraphs.

Figure 1

ELECTRON-TUBE TYPES

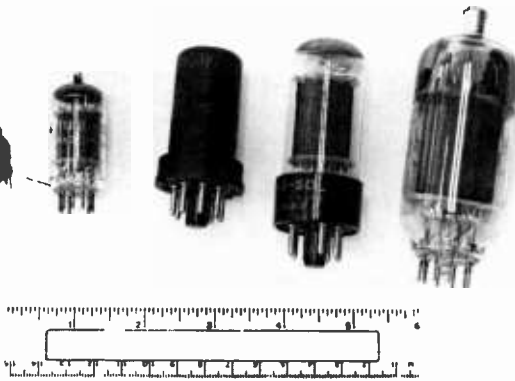

At the left are two Nuvistor types intended for vhf operation in TV tuners and receivers up to 450 MHz or so. Next is a typical miniature glass receiving tube alongside an old-style metal, octal-based tube. At the right are an octal-based glass audio tube and (at far right) a nine-pin based sweep tube intended for use in color television receivers (type 6LQ6). This type of tube is often used as a linear amplifier in amateur-type single-side-band transmitting equipment.

Cathode Types The emitters or cathodes as used in present-day thermionic electron tubes may be classified into two groups; the directly heated or *filament type* and the indirectly heated or *heater-cathode type*. Directly heated emitters may be further subdivided into three important groups, all of which are commonly used in modern vacuum tubes. These classifications are: the pure-tungsten filament, the thoriated-tungsten filament, and the oxide-coated filament.

The Pure-Tungsten Filament Pure-tungsten wire was used as the filament in nearly all the earlier transmitting and receiving tubes. However, the thermionic efficiency of tungsten wire as an emitter (the number of milliamperes emission per watt of filament-heating power) is quite low; the filaments become fragile after use; their life is rather short, and they are susceptible to burnout at any time. Pure-tungsten filaments must be run at bright white heat (about 2500° Kelvin). For these reasons, tungsten filaments have been replaced in all applications where another type of filament could be used. They are, however, occasionally employed in large water-cooled tubes and in certain large, high-power air-cooled triodes where another filament type would be unsuitable. Tungsten filaments are the most satisfactory for high-power, high-voltage tubes where the emitter is subjected to positive ion bombardment caused by the residual gas content of the

tubes. Tungsten is not adversely affected by such bombardment.

The Thoriated-Tungsten Filament In the course of experiments made upon tungsten emitters, it was found that filaments made from tungsten having a small amount of thoria (thorium oxide) as an impurity had much greater emission than those made from the pure metal. Subsequent development has resulted in the highly efficient carburized thoriated-tungsten filament as used in many medium-power transmitting tubes today.

Thoriated-tungsten emitters consist of a tungsten wire containing from 1% to 2% thoria. The activation process varies between different manufacturers of vacuum tubes, but it is essentially as follows: (1) the tube is evacuated; (2) the filament is burned for a short period at about 2800° Kelvin to clean the surface and reduce some of the thoria within the filament to metallic thorium; (3) the filament is burned for a longer period at about 2100° Kelvin to form a layer of thorium on the surface of the tungsten; (4) the temperature is reduced to about 1600° Kelvin and some pure hydrocarbon gas is admitted to form a layer of tungsten carbide on the surface of the tungsten. This layer of tungsten carbide reduces the rate of thorium evaporation from the surface at the normal operating temperature of the filament and thus increases the operating life of the vacuum tube. Thorium evaporation from the surface is a natu-



Figure 2

VHF and UHF TUBE TYPES

At the left is an 8058 nuvistor tetrode, representative of the family of small vhf types useful in receivers and low power transmitters. The second type is an 6816 planar tetrode rated at 180 watts input to 1215 MHz. The third tube from the left is a 3CX100A5 planar triode, an improved and ruggedized version of the 2C39A, and rated at 100 watts input to 2900 MHz. The fourth tube from the left is the

X-843 (Eimac) planar triode designed to deliver over 100 watts at 2100 MHz. The tube is used in a grounded-grid cavity configuration. The tube to the right is a 7213 planar tetrode, rated at 2500 watts input to 1215 MHz. All of these vhf/uhf negative-grid tubes make use of ceramic insulation for lowest envelope loss at the higher frequencies and the larger ones have coaxial bases for use in resonant cavities.

ral consequence of the operation of the thoriated-tungsten filament. The carburized layer on the tungsten wire plays another role in acting as a reducing agent to produce new thorium from the thoria to replace that lost by evaporation. This new thorium continually diffuses to the surface during the normal operation of the filament.

The last process, (5), in the activation of a thoriated-tungsten filament consists of re-evacuating the envelope and then burning or aging the new filament for a considerable period of time at the normal operating temperature of approximately 1900° K.

One thing to remember about any type of filament, particularly the thoriated type, is that the emitter deteriorates practically as fast when "standing by" (no plate current) as it does with any normal amount of emission load. Also, a thoriated filament may be either temporarily or permanently damaged by a heavy overload which may strip the surface layer of thorium from the filament.

Reactivating Thoriated-Tungsten Filaments

Thoriated-tungsten filaments (and *only* thoriated-tungsten filaments) which have lost emission

as a result of insufficient filament voltage, a severe temporary overload, a less severe extended overload, or even normal operation may quite frequently be reactivated to their original characteristics by a process similar to that of the original activation. However, only filaments which have not approached too close to the end of their useful life may be successfully reactivated.

The actual process of reactivation is relatively simple. The tube which has gone "flat" is placed in a socket to which only the two filament wires have been connected. The filament is then "flashed" for about 20 to 40 seconds at about 1½ times normal rated voltage. The filament will become extremely bright during this time and, if there is still some thoria left in the tungsten and if the tube did not originally fail as a result of an air leak, some of this thoria will be reduced to metallic thorium. The filament is then burned at 15 to 25 percent overvoltage for from 30 minutes to 3 to 4 hours to bring this new thorium to the surface.

The tube should then be tested to see if it shows signs of renewed life. If it does, but is still weak, the burning process should be continued at about 10 to 15 percent over-

voltage for a few more hours. This should bring it back almost to normal. If the tube checks still very low after the first attempt at reactivation, the complete process can be repeated as a last effort.

The Oxide-Coated Filament The most efficient of all modern filaments is the oxide-coated type which

consists of a mixture of barium and strontium oxides coated on a nickel alloy wire or strip. This type of filament operates at a dull-red to orange-red temperature (1050° to 1170° K) at which temperature it will emit large quantities of electrons. The oxide-coated filament is somewhat more efficient than the thoriated-tungsten type in small sizes and it is considerably less expensive to manufacture. For this reason all receiving tubes and quite a number of the low-powered transmitting tubes use the oxide-coated filament. Another advantage of the oxide-coated emitter is its extremely long life — the average tube can be expected to run from 3000 to 5000 hours, and when loaded very lightly, tubes of this type have been known to give 50,000 hours of life before their characteristics changed to any great extent.

Oxide filaments are unsatisfactory for use at very high plate voltage because: (1) their activity is seriously impaired by the high temperature necessary to de-gas the high-voltage tubes and, (2) the positive ion bombardment which takes place even in the best evacuated high-voltage tube causes destruction of the oxide layer on the surface of the filament.

Oxide-coated emitters have been found capable of emitting an enormously large current pulse with a high applied voltage for a very short period of time without damage. This characteristic has proved to be of great value in radar work. For example, the relatively small cathode in a microwave magnetron may be called on to deliver 25 to 50 amperes at an applied voltage of perhaps 25,000 volts for a period in the order of one microsecond. After this large current pulse has been passed, plate voltage normally will be removed for 1000 microseconds or more so that the cathode surface may recover in time for the next pulse of current. If the cathode were to be subjected to a continuous current drain of this magnitude, it

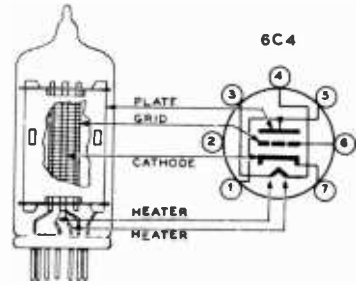

Figure 3

CUTAWAY DRAWING OF A 6C4 TRIODE

would be destroyed in an exceedingly short period of time.

The activation of oxide-coated filaments also varies with tube manufacturers but consists essentially in heating the wire which has been coated with a mixture of barium and strontium carbonates to a temperature of about 1500° Kelvin for a time and then applying a potential of 100 to 200 volts through a protective resistor to limit the emission current. This process thermally reduces the carbonates to oxides, cleans the filament surface of foreign materials, and activates the cathode surface.

Reactivation of oxide-coated filaments is not possible since there is always more than sufficient reduction of the oxides and diffusion of the metals to the surface of the filament to meet the emission needs of the cathode.

The Heater Cathode The heater-type cathode was developed as a result of the requirement for a type of emitter which could be operated from alternating current and yet would not introduce a-c ripple modulation even when used in low-level stages. It consists essentially of a small nickel-alloy cylinder with a coating of strontium and barium oxides on its surface similar to the coating used on the oxide-coated filament. Inside the cylinder is an insulated heater element consisting usually of a double spiral of tungsten wire. The heater may operate on any voltage from 2 to 117 volts, although 6.3 is the most common value. The heater is operated at quite a high temperature so that the cathode itself usually may be brought to operating temperature in a matter of 15 to 30 seconds. Heat-coupling between the heater and the

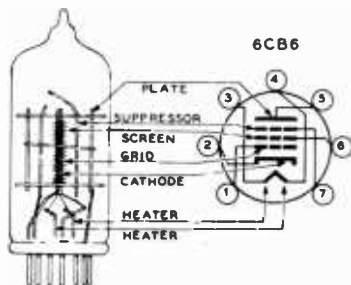

Figure 4

CUTAWAY DRAWING OF A 6CB6 PENTODE

cathode is mainly by radiation, although there is some thermal conduction through the insulating coating on the heater wire, since this coating is also in contact with the cathode thimble.

Indirectly heated cathodes are employed in all a-c operated tubes which are designed to operate at a low level either for r-f or a-f use. However, some receiver power tubes use heater cathodes (6L6, 6V6, 6F6, and 6K6-GT) as do some of the low-power transmitter tubes (802, 807, 815, 3E29, 2E26, 5763, 6146, etc.). Heater cathodes are employed almost exclusively when a number of tubes are to be operated in series as in an a-c/d-c receiver. A heater cathode is often called a *unipotential cathode* because there is no voltage drop along its length as there is in the directly heated or filament cathode.

The Emission Equation

The emission of electrons from a heated cathode is quite similar to the evaporation of molecules from the surface of a liquid. The molecules which leave the surface are those having sufficient kinetic (heat) energy to overcome the forces at the surface of the liquid. As the temperature of the liquid is raised, the average velocity of the molecules is increased, and a greater number of molecules will acquire sufficient energy to be evaporated. The evaporation of electrons from the surface of a thermionic emitter is similarly a function of average electron velocity, and hence is a function of the temperature of the emitter.

Electron emission per unit area of emitting surface is a function of the temperature (T) in degrees Kelvin, the work function of emitting surface b (which is a measure of the surface forces of the material and hence of the energy required of the electron before it may escape), and of the constant (A) which also varies with the emitting surface. The relationship between emission current in amperes per square centimeter (I) and the above quantities can be expressed as:

$$I = AT^2e^{-b/T}$$

Secondary Emission

The bombarding of most metals and a few insulators by electrons will result in the emission of other electrons by a process called *secondary emission*. The secondary electrons are literally knocked from the surface layers of the bombarded material by the primary electrons which strike the material. The number of secondary electrons emitted per primary electron varies from a very small percentage to as high as 5 to 10 secondary electrons per primary.

The phenomena of secondary emission is undesirable for most thermionic electron tubes. However, the process is used to advantage in certain types of electron tubes such as the *image orthicon* (TV camera tube) and the *electron-multiplier* type of photoelectric cell. In types of electron tubes which make use of secondary emission, such as the type 931 photocell, the secondary-electron emitting surfaces are specially treated to provide a high ratio of secondary to primary electrons. Thus a high degree of current amplification in the electron-multiplier section of the tube is obtained.

The Space-Charge Effect

As a cathode is heated so that it begins to emit, those electrons which have been discharged into the surrounding space form a negatively charged cloud in the immediate vicinity of the cathode. This cloud of electrons around the cathode is called the *space charge*. The electrons comprising the charge are continuously changing, since those electrons making up the original charge fall back into the cathode and are replaced by others emitted by it.

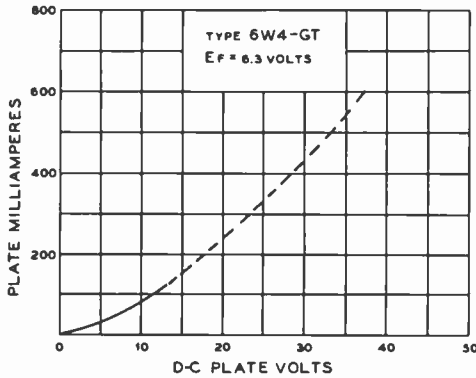

Figure 5

AVERAGE PLATE CHARACTERISTICS OF A POWER DIODE

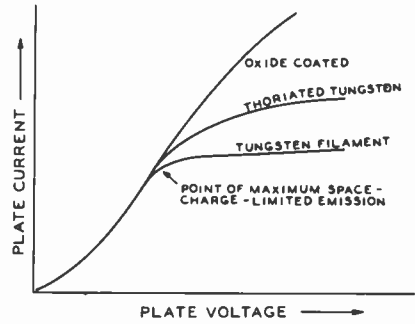

Figure 6

MAXIMUM SPACE-CHARGE-LIMITED EMISSION FOR DIFFERENT TYPES OF EMITTERS

4-2 The Diode

If a cathode capable of being heated either indirectly or directly is placed in an evacuated envelope along with a plate, such a two-element vacuum tube is called a *diode*. The diode is the simplest of all vacuum tubes and is the fundamental type from which all the others are derived.

Characteristics of the Diode When the cathode within a diode is heated, it will be found that a few of the electrons leaving the cathode will leave with sufficient velocity to reach the plate. If the plate is electrically connected back to the cathode, the electrons which have had sufficient velocity to arrive at the plate will flow back to the cathode through the external circuit. This small amount of initial plate current is an effect found in all two-element vacuum tubes.

If a battery or other source of d-c voltage is placed in the external circuit between the plate and cathode so that it places a positive potential on the plate, the flow of current from the cathode to plate will be increased. This is due to the strong attraction offered by the positively charged plate for any negatively charged particles (figure 5).

The Three-Halves Power Law At moderate values of plate voltage the current flow from cathode to anode is limited by the space charge of electrons around the cathode. Increased values of plate voltage will tend to neutralize a greater portion of the cathode space charge and hence will cause a greater current to flow.

Under these conditions, with plate current limited by the cathode space charge, the plate current is not linear with plate voltage. In fact it may be stated in general that the plate-current flow in diode tubes does not obey Ohm's Law. Rather, plate current increases as the three-halves power of the plate voltage. The relationship between plate voltage, (E) and cathode current (I) can be expressed as:

$$I = K E^{3/2}$$

where,

K is a constant determined by the geometry of the element structure within the diode tube.

Plate-Current Saturation As plate voltage is raised to the potential where the cathode space charge is neutralized, all the electrons that the cathode is capable of emitting are being attracted to the plate. The electron tube is said then to have reached *saturation* plate current.

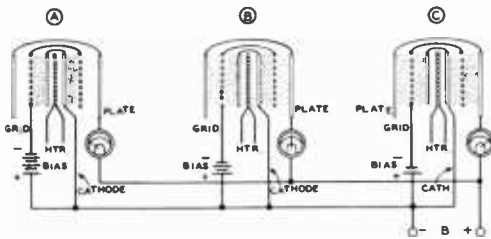

Figure 7

ACTION OF THE GRID IN A TRIODE

(A) shows the triode tube with cutoff bias on the grid. Note that all the electrons emitted by the cathode remain inside the grid mesh. (B) shows the same tube with an intermediate value of bias on the grid. Note the medium value of plate current and the fact that there is a reserve of electrons remaining within the grid mesh. (C) shows the operation with a relatively small amount of bias which with certain tube types will allow substantially all the electrons emitted by the cathode to reach the plate. Emission is said to be saturated in this case. In a majority of tube types a high value of positive grid voltage is required before plate-current saturation takes place.

Further increase in plate voltage will cause only a relatively small increase in plate current. The initial point of plate-current saturation is sometimes called the point of *Maximum Space-Charge-Limited Emission*.

The degree of flattening in the plate-voltage plate-current curve after the limited-emission point will vary with different types of cathodes. This effect is shown in figure 6. The flattening is quite sharp with a pure tungsten emitter. With thoriated tungsten the flattening is smoothed somewhat, while with an oxide-coated cathode the flattening is quite gradual. The gradual saturation in emission with an oxide-coated emitter is generally considered to result from a lowering of the surface work function by the field at the cathode resulting from the plate potential.

The degree of flattening in the plate-voltage plate-current curve after the limited-emission point will vary with different types of cathodes. This effect is shown in figure 6. The flattening is quite sharp with a pure tungsten emitter. With thoriated tungsten the flattening is smoothed somewhat, while with an oxide-coated cathode the flattening is quite gradual. The gradual saturation in

emission with an oxide-coated emitter is generally considered to result from a lowering of the surface work function by the field at the cathode resulting from the plate potential.

Electron Energy Dissipation

The current flowing in the plate-cathode space of a conducting electron tube represents the energy required to accelerate electrons from the zero potential of the cathode space charge to the potential of the anode. Then, when these accelerated electrons strike the anode, the energy associated with their velocity is immediately released to the anode structure. In normal electron tubes this energy release appears as heating of the plate or anode structure.

4-3 The Triode

If an element consisting of a mesh or spiral of wire is inserted concentric with the plate and between the plate and the cathode, such an element will be able to control by electrostatic action the cathode-to-plate current of the tube. The new element is called a *grid*, and a vacuum tube containing a cathode, grid, and plate is commonly called a *triode*.

Action of the Grid If this new element through which the electrons must pass in their course from cathode to plate is made negative with respect to the cathode, the negative charge on this grid will effectively repel the negatively charged electrons (like charges repel; unlike charges attract) back into the space charge surrounding the cathode. Hence, the number of electrons which are able to pass through the grid mesh and reach the plate will be reduced, and the plate current will be reduced accordingly. If the charge on the grid is made sufficiently negative, all the electrons leaving the cathode will be repelled back to it and the plate current will be reduced to zero. Any d-c voltage placed on a grid is called a *bias* (especially so when speaking of a control grid). The smallest negative voltage which will cause cutoff of plate current at a particular plate voltage is called the value of *cutoff bias* (figure 7).

Amplification Factor The amount of plate current in a triode is a result of the net field at the cathode from interaction between the field caused by the grid bias and that caused by the plate voltage. Hence, both grid bias and plate voltage affect the plate current. In all normal tubes a small change in grid bias has a considerably greater effect than a similar change in plate voltage. The ratio between the change in grid bias and the change in plate current which will cause the same small change in plate current is called the *amplification factor* or μ of the electron tube. Expressed as an equation:

$$\mu = - \frac{\Delta E_b}{\Delta E_c}$$

with I_b constant (Δ represents a small increment).

The μ can be determined experimentally by making a small change in grid bias, thus slightly changing the plate current. The plate current is then returned to the original value by making a change in the plate voltage. The ratio of the change in plate voltage to the change in grid voltage is the μ of the tube under the operating conditions chosen for the test. The μ of modern triodes ranges from 5 to 200.

Current Flow in a Triode In a diode it was shown that the electrostatic field at the cathode was proportional to the plate potential (E_b) and that the total cathode current was proportional to the three-halves power of the plate voltage. Similarly, in a triode it can be shown that the field at the cathode space charge is proportional to the equivalent voltage ($E_c + E_b/\mu$), where the amplification factor (μ) actually represents the relative effectiveness of grid potential and plate potential in producing a field at the cathode.

It would then be expected that the cathode current in a triode would be proportional to the three-halves power of ($E_c + E_b/\mu$). The cathode current of a triode can be represented with fair accuracy by the expression:

$$\text{cathode current} = K \left(E_c + \frac{E_b}{\mu} \right)^{3/2}$$

where,

K is a constant determined by element geometry within the triode.

Plate Resistance The *dynamic plate resistance* of a vacuum tube is the ratio of a change in plate voltage to the change in plate current which the change in plate voltage produces. To be accurate, the changes should be very small with respect to the operating values. Expressed as an equation:

$$r_p = \frac{\Delta E_b}{\Delta I_c}$$

The dynamic plate resistance can also be determined by the experiment mentioned above. By noting the change in plate current as it occurs when the plate voltage is changed (grid voltage held constant), and by dividing the latter by the former, the plate resistance can be determined. Plate resistance is expressed in ohms.

Transconductance The *mutual conductance*, also referred to as *transconductance*, is the ratio of a change in the plate current to the change in grid voltage which brought about the plate-current change, the plate voltage being held constant. Expressed as an equation:

$$G_m = \frac{\Delta I_b}{\Delta E_c}$$

where,

E_b is held constant.

The transconductance is also numerically equal to the amplification factor divided by the plate resistance. $G_m = \mu/r_p$.

Transconductance is most commonly expressed in microreciprocal-ohms or *micromhos*. However, since transconductance expresses change in plate current as a function of a change in grid voltage, a tube is often said to have a transconductance of so many milliamperes per volt. If the transconductance in milliamperes per volt is multiplied by 1000 it will then be expressed in micromhos. Thus the transconductance of a 6A3 could be called either 5.25 ma/volt or 5250 micromhos.

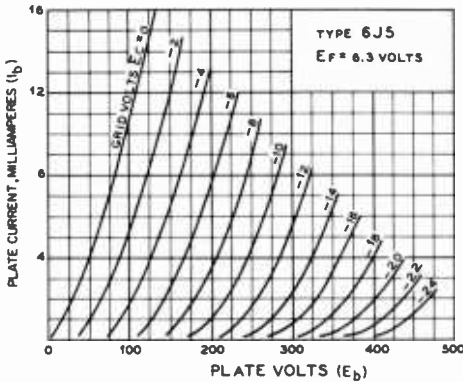

Figure 8

**NEGATIVE-GRID CHARACTERISTICS
(I_b vs. E_b CURVES) OF A
TYPICAL TRIODE**

Average plate characteristics of this form are most commonly used in determining the class-A operating characteristics of a triode amplifier stage.

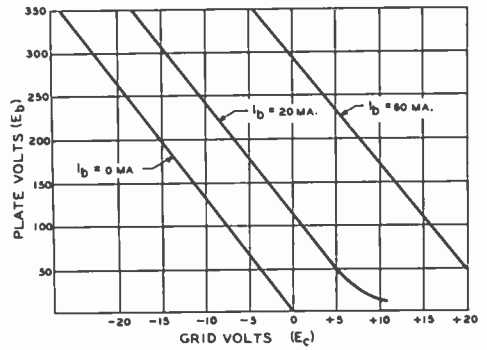

Figure 10

**CONSTANT CURRENT (E_b vs. E_c)
CHARACTERISTICS OF A
TYPICAL TRIODE TUBE**

This type of graphical representation is used for class-C amplifier calculations since the operating characteristic of a class-C amplifier is a straight line when drawn on a constant-current graph.

Characteristic Curves of a Triode Tube The operating characteristics of a triode tube may be summarized in three sets of curves. The I_b vs. E_b curve (figure 8), the I_b vs. E_c curve (figure

9) and the E_b vs. E_c curve (figure 10). The plate resistance (r_p) of the tube may be observed from the I_b vs. E_b curve, the transconductance (G_m) may be observed from the I_b vs. E_c curve and the amplification factor (μ) may be determined from the E_b vs. E_c curve.

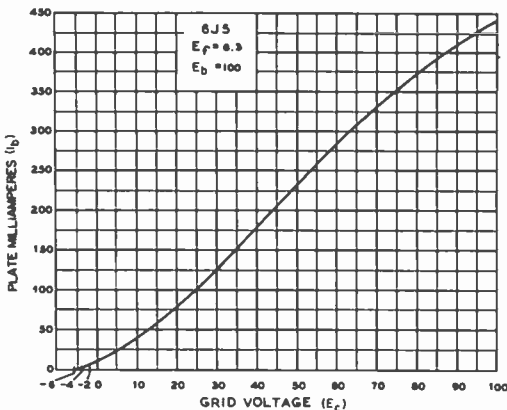

Figure 9

**POSITIVE-GRID CHARACTERISTICS
(I_b vs. E_c) OF A TYPICAL TRIODE**

Plate characteristics of this type are most commonly used in determining the pulse-signal operating characteristics of a triode amplifier stage. Note the large emission capability of the oxide-coated heater cathode in tubes of the general type of the 6J5.

The Load Line A load line is a graphical representation of the voltage on the plate of a vacuum tube and the current passing through the plate circuit of the tube for various values of plate load resistance and plate supply voltage. Figure 11 illustrates a triode tube with a resistive plate load, and a supply voltage of 300 volts. The voltage at the plate of the tube (e_b) may be expressed as:

$$e_b = E_b - (i_b \times R_L)$$

where,

- E_b is the plate supply voltage,
- i_b is the plate current,
- R_L is the load resistance in ohms.

Assuming various values of i_b flowing in the circuit, controlled by the internal resistance of the tube (a function of the grid

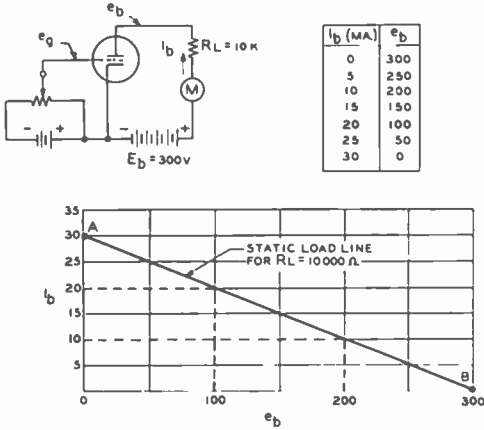

Figure 11

The static load line for a typical triode tube with a plate load resistance of 10,000 ohms.

bias), values of plate voltage may be plotted as shown for each value of plate current (i_b). The line connecting these points is called the *load line* for the particular value of plate load resistance used. The *slope* of the load line is equal to the ratio of the lengths of the vertical and horizontal projections of any segment of the load line.

For this example it is:

$$\text{slope} = -\left(\frac{.01 - .02}{100 - 200}\right) = -.0001 = -\frac{1}{10,000}$$

The slope of the load line is equal to $-1/R_L$. At point A on the load line, the voltage across the tube is zero. This would be true for a perfect tube with zero internal voltage drop, or if the tube is short-circuited from cathode to plate. Point B on the load line corresponds to the cutoff point of the tube, where no plate current is flowing. The operating range of the tube lies between these two extremes. For additional information regarding *dynamic* load lines, the reader

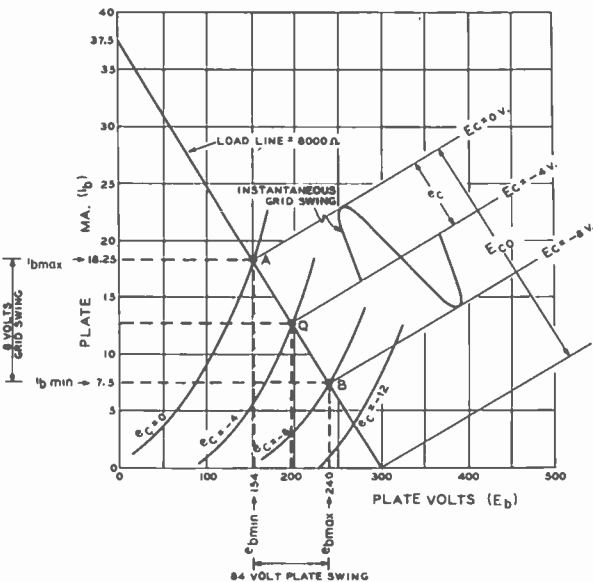

Figure 13
APPLICATION OF i_b vs. E_i CHARACTERISTICS OF A VACUUM TUBE

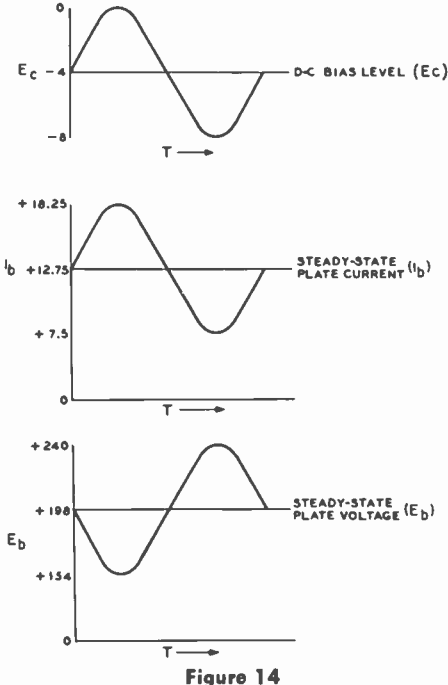

Figure 14
POLARITY REVERSAL BETWEEN GRID AND PLATE VOLTAGES

is referred to the *Radiotron Designer's Handbook* distributed by Radio Corporation of America.

Application of Tube Characteristics As an example of the application of tube characteristics, the constants of the triode amplifier circuit shown in figure 12 may be considered. The plate supply is 300 volts, and the plate load is 8000 ohms. If the tube is considered to be an open circuit no plate current will flow, and there is no voltage drop across the plate load resistor (R_L). The plate voltage on the tube is therefore 300 volts. If, on the other hand, the tube is considered to be a short circuit, maximum possible plate current flows and the full 300 volt drop appears across R_L . The plate voltage is zero, and the plate current is $300/1000$, or 37.5 milliamperes. These two extreme conditions define the ends of the load line on the I_b vs. E_b characteristic curve figure 13.

For this application, the grid of the tube is returned to a steady biasing voltage of -4

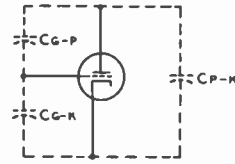

Figure 15
SCHEMATIC REPRESENTATION OF INTERELECTRODE CAPACITANCE

volts. The steady or quiescent operation of the tube is determined by the intersection of the load line with the -4 -volt curve at point Q. By projection from point Q through the plate-current axis it is found that the value of plate current with no signal applied to the grid is 12.75 milliamperes. By projection from point Q through the plate-voltage axis it is found that the quiescent plate voltage is 198 volts. This leaves a drop of 102 volts across R_L , which is borne out by the relation $0.01275 \times 8000 = 102$ volts.

An alternating voltage of 4 volts maximum swing about the normal bias value of -4 volts is applied now to the grid of the triode amplifier. This signal swings the grid in a positive direction to 0 volts, and in a negative direction to -8 volts, and establishes the *operating region* of the tube along the load line between points A and B. Thus the maxima and minima of the plate voltage and plate current are established. By projection from points A and B through the plate-current axis the maximum instantaneous plate current is found to be 18.25 milliamperes and the minimum is 7.5 milliamperes. By projections from points A and B through the plate-voltage axis the minimum instantaneous plate-voltage swing is found to be 154 volts and the maximum is 240 volts.

By this graphical application of the I_b vs. E_b characteristic of the 6SN7 triode the operation of the circuit illustrated in figure 12 becomes apparent. A voltage variation of 8 volts (peak to peak) on the grid produces a variation of 84 volts at the plate.

Polarity Inversion When the signal voltage applied to the grid has its maximum positive instantaneous value the

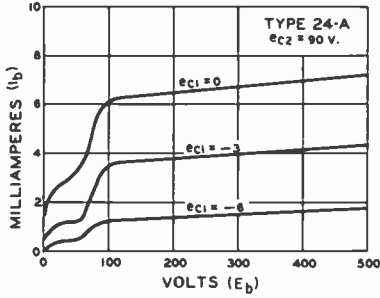

Figure 16

TYPICAL I_b vs. E_b TETRODE CHARACTERISTIC CURVES

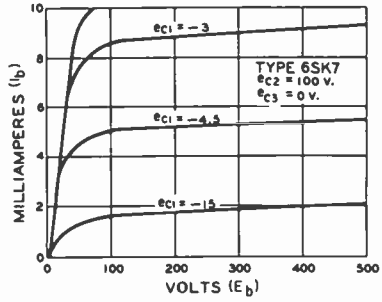

Figure 17

TYPICAL I_b vs. E_b PENTODE CHARACTERISTIC CURVES

plate current is also maximum. Reference to figure 12 shows that this maximum plate current flows through plate-load resistor R_L , producing a maximum voltage drop across it. The lower end of R_L is connected to the plate supply, and is therefore held at a constant potential of 300 volts. With maximum voltage drop across the load resistor, the upper end of R_L is at a minimum instantaneous voltage. The plate of the tube is connected to this end of R_L , and is therefore at the same minimum instantaneous potential.

This polarity reversal between instantaneous grid and plate voltages is further clarified by a consideration of Kirchhoff's law as it applies to series resistance. The sum of the IR drops around the plate circuit must at all times equal the supply voltage of 300 volts. Thus when the instantaneous voltage drop across R_L is maximum, the voltage drop across the tube is minimum, and their sum must equal 300 volts. The variations of grid voltage, plate current and plate voltage about their steady-state values is illustrated in figure 14.

Interelectrode Capacitance Capacitance always exists between any two pieces of metal separated by a dielectric. The exact amount of capacitance depends on the size of the metal pieces, the dielectric between them, and the type of dielectric. The electrodes of a vacuum tube have a similar characteristic known as *interelectrode capacitance*, illustrated in figure 15. These direct capacitances in a triode are: grid-to-cathode capacitance, grid-to-plate capacitance, and

plate-to-cathode capacitance. The interelectrode capacitance, though very small, has a coupling effect, and often can cause unbalance in a particular circuit. At very-high frequencies (vhf), interelectrode capacitances become very objectionable and prevent the use of conventional tubes at these frequencies. Special vhf tubes must be used which are characterized by very small electrodes and close internal spacing of the elements of the tube.

4-4 Tetrode and Screen-Grid Tubes

Many desirable characteristics can be obtained in a vacuum tube by the use of more than one grid. The most common multielement tube is the tetrode (four electrodes). Other tubes containing as many as eight electrodes are available for special applications.

The Tetrode The quest for a simple and easily usable method of eliminating the effects of the grid-to-plate capacitance of the triode led to the development of the *screen-grid* tube, or *tetrode*. When another grid is added between the grid and plate of a vacuum tube the tube is called a tetrode, and because the new grid is called a *screen*, as a result of its screening or shielding action, the tube is often called a screen-grid tube. The interposed screen grid acts as an electrostatic shield between the grid and plate, with the consequence that the grid-to-plate capacitance is reduced. Although the screen grid is maintained at a

positive voltage with respect to the cathode of the tube, it is maintained at ground potential with respect to r.f. by means of a bypass capacitor of very low reactance at the frequency of operation.

In addition to the shielding effect, the screen grid serves another very useful purpose. Since the screen is maintained at a positive potential, it serves to increase or accelerate the flow of electrons to the plate. There being large openings in the screen mesh, most of the electrons pass through it and on to the plate. Due also to the screen, the plate current is largely independent of plate voltage, thus making for high amplification. When the screen voltage is held at a constant value, it is possible to make large changes in plate voltage without appreciably affecting the plate current, (figure 16).

When the electrons from the cathode approach the plate with sufficient velocity, they dislodge electrons on striking the plate. This effect of *bombarding* the plate with high-velocity electrons, with the consequent dislodgement of other electrons from the plate, gives rise to the condition of secondary emission which has been discussed in a previous paragraph. This effect can cause no particular difficulty in a triode because the secondary electrons so emitted are eventually attracted back to the plate. In the screen-grid tube, however, the screen is close to the plate and is maintained at a positive potential. Thus, the screen will attract these electrons which have been knocked from the plate, particularly when the plate voltage falls to a lower value than the screen voltage, with the result that the plate current is lowered and the amplification is decreased.

In the application of tetrodes, it is necessary to operate the plate at a high voltage in relation to the screen in order to overcome these effects of *secondary emission*.

The Pentode The undesirable effects of secondary emission from the plate can be greatly reduced if yet another element is added between the screen and plate. This additional element is called a *suppressor*, and tubes in which it is used are called *pentodes*. The suppressor grid is sometimes connected to the cathode within the tube; sometimes it is brought out to a connecting pin on the tube base, but in any case it is established negative with respect to the

minimum plate voltage. The secondary electrons that would travel to the screen if there were no suppressor are diverted back to the plate. The plate current is, therefore, not reduced and the amplification possibilities are increased (figure 17).

Pentodes for audio applications are designed so that the suppressor increases the limits to which the plate voltage may swing; therefore the consequent power output and gain can be very great. Pentodes for radio-frequency service function in such a manner that the suppressor allows high voltage gain, at the same time permitting fairly high gain at low plate voltage. This holds true even if the plate voltage is the same or slightly lower than the screen voltage.

Remote-Cutoff Tubes *Remote-cutoff* tubes (variable- μ) are screen-grid tubes in which the control grid structure has been physically modified so as to cause the plate current of the tube to drop off gradually, rather than to have a well-defined cutoff point (figure 18). A non-uniform control-grid structure is used, so that the amplification factor is different for different parts of the control grid.

Remote-cutoff tubes are used in circuits where it is desired to control the amplification by varying the control-grid bias. The characteristic curve of an ordinary screen-grid tube has considerable curvature near the plate-current cutoff point, while the curve of a remote-cutoff tube is much more linear (figure 19). The remote-cutoff tube minimizes cross-talk interference that would otherwise be produced. Examples of remote cutoff tubes are: 6BD6, 6BA6, 6SG7 and 6SK7.

Beam-Power Tubes A *beam-power* tube makes use of another method of suppressing secondary emission. In this tube there are four electrodes: a cathode, a grid, a screen, and a plate, so spaced and placed that secondary emission from the plate is suppressed without actual power loss. Because of the manner in which the electrodes are spaced, the electrons which travel to the plate are slowed down when the plate voltage is low, almost to zero velocity in a certain region between screen and plate. For this reason the electrons form a stationary cloud, or *space charge*. The effect of this

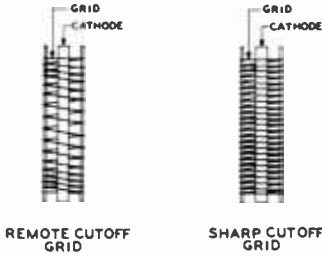

Figure 18

REMOTE-CUTOFF GRID STRUCTURE

space charge is to repel secondary electrons emitted from the plate and thus cause them to return to the plate. In this way, secondary emission is suppressed.

Another feature of the beam-power tube is the low current drawn by the screen. The screen and the grid are spiral wires wound so that each turn in the screen is shaded from the cathode by a grid turn. This alignment of the screen and the grid causes the electrons to travel in sheets between the turns of the screen so that very few of them strike the screen itself. This formation of the electron stream into sheets or beams increases the charge density in the screen-plate region and assists in the creation of the space charge in this region.

Because of the effective suppressor action provided by the space charge, and because of the low current drawn by the screen, the beam-power tube has the advantages of high power output, high power sensitivity, and high efficiency. The 6AQ5 is such a beam-power tube, designed for use in the power-amplifier stages of receivers and speech amplifiers or modulators. Larger tubes employing the beam-power principle are being made

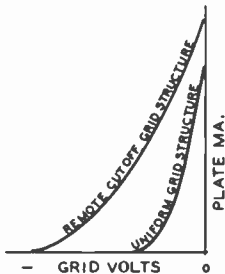

Figure 19

ACTION OF A REMOTE-CUTOFF GRID STRUCTURE

by various manufacturers for use in the radio-frequency stages of transmitters. These tubes feature extremely high power sensitivity (a very small amount of driving power is required for a large output), good plate efficiency, and low grid-to-plate capacitance. Examples of these tubes are 813, 4-250A, 4CX250B, etc.

Grid-Screen Mu Factor The *grid-screen μ factor (μ_s)* is analogous to the amplification factor in a triode, except that the screen of a pentode or tetrode is substituted for the plate of a triode. μ_s denotes the ratio of a change in grid voltage to a change in screen voltage, each of which will produce the same change in screen current. Expressed as an equation:

$$\mu_s = \frac{\Delta E_{c2}}{\Delta E_{c1}}$$

where

I_{c2} is held constant.

The grid-screen μ factor is important in determining the operating bias of a tetrode or pentode tube. The relationship between control-grid potential and screen potential determines the plate current of the tube as well as the screen current since the plate current is essentially independent of the plate voltage in tubes of this type. In other words, when the tube is operated at cutoff bias as determined by the screen voltage and the grid-screen μ_s factor (determined in the same way as with a triode, by dividing the operating voltage by the μ factor), the plate current will be substantially at cutoff, as will be the screen current. The grid-screen μ_s factor is numerically equal to the amplification factor of the same tetrode or pentode tube when it is triode connected.

Current Flow in Tetrodes and Pentodes The following equation is the expression for total cathode current in a triode tube. The expression for the total cathode current of a tetrode and a pentode tube is the same, except that the screen-grid voltage and the grid-screen μ_s factor are used in place of the plate voltage and μ of the triode.

$$\text{Cathode current} = K \left(E_{c1} + \frac{E_{c2}}{\mu_s} + \frac{E_b}{\mu} \right)^{3/2}$$

Cathode current, of course, is the sum of the screen and plate currents plus control-grid current in the event that the control grid is positive with respect to the cathode. *It will be noted that total cathode current is independent of plate voltage in a tetrode or pentode.* Also, in the usual tetrode or pentode the plate current is substantially independent of plate voltage over the usual operating range—which means simply that the effective plate resistance of such tubes is relatively high. However, when the plate voltage falls below the normal operating range, the plate current falls sharply, while the screen current rises to such a value that the total cathode current remains substantially constant. Hence, the screen grid in a tetrode or pentode will almost invariably be damaged by excessive dissipation if the plate voltage is removed while the screen voltage is still being applied from a low-impedance source.

The Effect of Grid Current The current equations show how the total cathode current in triodes, tetrodes, and pentodes is a function of the potentials applied to the various electrodes. If only one electrode is positive with respect to the cathode (such as would be the case in a triode acting as a class-A amplifier) all the cathode current goes to the plate. But when both screen and plate are positive in a tetrode or pentode, the cathode current divides between the two elements. Hence the screen current is taken from the total cathode current, while the balance goes to the plate. Further, if the control grid in a tetrode or pentode is operated at a positive potential the total cathode current is divided between all three elements which have a positive potential. In a tube which is receiving a large excitation voltage, it may be said that the control grid robs electrons from the output electrode during the period that the grid is positive, making it always necessary to limit the peak-positive excursion of the control grid.

Coefficients of Tetrodes and Pentodes In general it may be stated that the amplification factor of tetrode and pentode tubes is a coefficient which is not of much use to the designer. In fact the amplification factor is seldom given on the design-data sheets of such tubes. Its value

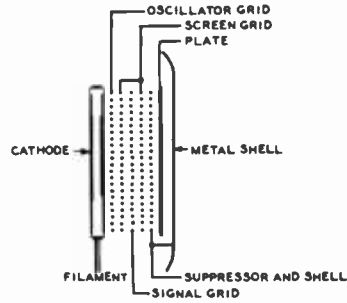

Figure 20
GRID STRUCTURE OF 6SA7
CONVERTER TUBE

is usually very high, due to the relatively high plate resistance of such tubes, but bears little relationship to the stage gain which actually will be obtained with such tubes.

On the other hand, the *grid-plate transconductance* is the most important coefficient of pentode and tetrode tubes. Gain per stage can be computed directly when the G_m is known. The grid-plate transconductance of a tetrode or pentode tube can be calculated through use of the expression:

$$G_m = \frac{\Delta I_b}{\Delta E_c}$$

with E_{c2} and E_b constant.

The plate resistance of such tubes is of less importance than in the case of triodes, though it is often of value in determining the amount of damping a tube will exert on the impedance in its plate circuit. Plate resistance is calculated from:

$$r_p = \frac{\Delta E_b}{\Delta I_b}$$

with E_{c1} and E_{c2} constant.

4-5 Mixer and Converter Tubes

The superheterodyne receiver always includes at least one stage for changing the frequency of the incoming signal to the fixed frequency of the main intermediate-frequency amplifier in the receiver. This frequency-changing process is accomplished by selecting the beat-note difference frequency between a locally generated oscillation and

the incoming signal frequency. If the oscillator signal is supplied by a separate tube, the frequency changing tube is called a *mixer*. Alternatively, the oscillation may be generated by additional elements within the frequency-changer tube. In this case the frequency changer is commonly called a *converter* tube.

Conversion Conductance The *conversion conductance* (G_c) is a coefficient of interest in the case of mixer or converter tubes, or of conventional triodes, tetrodes, or pentodes operating as frequency changers. The conversion conductance is the ratio of a change in the signal-grid voltage at the input frequency to a change in the output current at the converted frequency. Hence G_c in a mixer is essentially the same as transconductance in an amplifier, with the exception that the input signal and the output current are on different frequencies. The value of G_c in conventional mixer tubes is from 300 to 3000 micromhos. The value of G_c in an amplifier tube operated as a mixer is approximately 0.3 the G_m of the tube operated as an amplifier. The voltage gain of a mixer stage is equal to $G_c \times R_L$, where R_L is the impedance of the plate load into which the mixer tube operates.

The Diode Mixer The simplest mixer tube is the diode. The noise figure, or figure of merit, for a mixer of this type is not as good as that obtained with other more complex mixers; however, the diode is useful as a mixer in uhf and vhf equipment where low interelectrode capacities are vital to circuit operation. Since the diode impedance is low, the local oscillator must furnish considerable power to the diode mixer. A good diode mixer has an over-all gain of about 0.5.

The Triode Mixer A triode mixer has better gain and a better noise figure than the diode mixer. At low frequencies, the gain and noise figure of a triode mixer closely approaches those figures obtained when the tube is used as an amplifier. In the uhf and vhf range, the efficiency of the triode mixer deteriorates rapidly. The optimum local-oscillator voltage for a triode

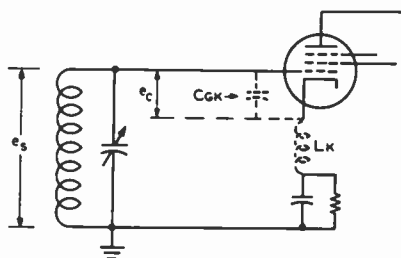

Figure 21

SHOWING THE EFFECT OF CATHODE LEAD INDUCTANCE

The degenerative action of cathode-lead inductance tends to reduce the effective grid-to-cathode voltage with respect to the voltage available across the input tuned circuit. Cathode-lead inductance also introduces undesirable coupling between the input and the output circuits.

mixer is about 0.7 as large as the cutoff bias of the triode. Very little local-oscillator power is required by a triode mixer.

Pentode Mixers and Converter Tubes A common multigrid converter tube for broadcast or shortwave use is the *pentagrid converter*, typified by the 6BE6, 6BA7, and 6SA7 tubes (figure 20). Operation of these converter tubes and pentode mixers will be covered in the Receiver Fundamentals Chapter.

4-6 Electron Tubes at Very-High Frequencies

As the frequency of operation of the usual type of electron tube is increased above about 20 MHz, certain assumptions which are valid for operation at lower frequencies must be re-examined. First, we find that lead inductances from the socket connections to the actual elements within the envelope no longer are negligible. Second, we find that electron transit time no longer may be ignored; an appreciable fraction of a cycle of input signal may be required for an electron to leave the cathode space charge, pass through the grid wires, and travel through the space between grid and plate.

Effects of Lead Inductance The effect of lead inductance is twofold. First, as shown in figure 21, the combination of grid-lead inductance, grid-

cathode capacitance, and cathode-lead inductance tends to reduce the effective grid-cathode signal voltage for a constant voltage at the tube terminals as the frequency is increased. Second, cathode-lead inductance tends to introduce undesired coupling between the various elements within the tube.

Tubes especially designed for vhf and uhf use have had their lead inductances minimized. The usual procedures for reducing lead inductance are: (1) using heavy lead conductors or several leads in parallel (examples are the 6J4 and 6AK5), (2) scaling down the tube in all dimensions to reduce both lead inductances and interelectrode capacitances (examples are the 6CW4, 6F4, and other nuvistor and miniature tubes), and (3) the use of very low-inductance extensions of the elements themselves as external connections (examples are lighthouse tubes such as the 2C40, planar tubes such as the 2C29, and many types of vhf transmitting tubes).

Effect of Transit Time When an electron tube is operated at a frequency high enough that electron transit time between cathode and plate is an appreciable fraction of a cycle at the input frequency, several undesirable effects take place. First, the grid takes power from the input signal even though the grid is negative at all times. This comes about since the grid will have changed its potential during the time required for an electron to pass from cathode to plate. Due to interaction, and a resulting phase difference between the field associated with the grid and that associated with a moving electron, the grid presents a resistance to an input signal in addition to its normal "cold" capacitance. Further, as a result of this action, plate current no longer is in phase with grid voltage.

An amplifier stage operating at a frequency high enough that *transit time* is appreciable:

(a) Is difficult to excite as a result of grid loss from the equivalent input grid resistance,

(b) Is capable of less output since transconductance is reduced and plate current is not in phase with grid voltage.

The effects of transit time increase with the square of the operating frequency, and they increase rapidly as frequency is in-

creased above the value where they become just appreciable. These effects may be reduced by scaling down tube dimensions; a procedure which also reduces lead inductance. Further, transit-time effects may be reduced by the obvious procedure of increasing electrode potentials so that electron velocity will be increased. However, due to the law of electron motion in an electric field, transit time is increased only as the square root of the ratio of operating potential increase; therefore this expedient is of limited value due to other limitations on operating voltages of small electron tubes.

4-7 Special Microwave Electron Tubes

Due primarily to the limitation imposed by transit time, conventional negative-grid electron tubes are capable of affording worthwhile amplification and power output only up to a definite upper frequency. This upper frequency limit varies from perhaps 100 MHz for conventional tube types to about 4000 MHz for specialized types such as the lighthouse tube. Above the limiting frequency, the conventional negative-grid tube no longer is practicable and recourse must be taken to totally different types of electron tubes in which electron transit time is not a limitation to operation. Three of the most important of such microwave tube types are the *klystron*, the *magnetron*, and the *traveling-wave tube*.

The Power Klystron The klystron is a type of electron tube in which electron transit time is used to advantage. Such tubes comprise, as shown in figure 22, a cathode, a focusing electrode, a resonator connected to a pair of grids which afford *velocity modulation* of the electron beam (called the "buncher"), a *drift space*, and another resonator connected to a pair of grids (called the "catcher"). A *collector* for the expended electrons may be included at the end of the tube, or the catcher may also perform the function of electron collection.

The tube operates in the following manner: The cathode emits a stream of electrons which is focused into a beam by the focusing electrode. The stream passes through the buncher where it is acted upon by any field

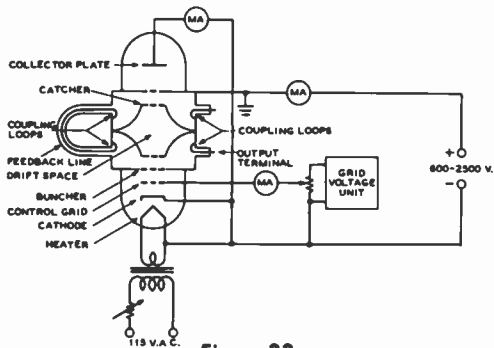

Figure 22

TWO-CAVITY KLYSTRON OSCILLATOR

A conventional two-cavity klystron is shown with a feedback loop connected between the two cavities so that the tube may be used as an oscillator.

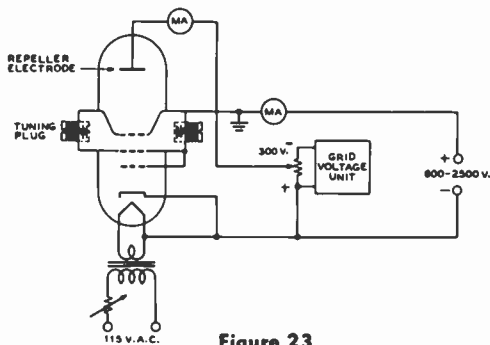

Figure 23

REFLEX KLYSTRON OSCILLATOR

A conventional reflex klystron oscillator of the type commonly used as a local oscillator in superheterodyne receivers operating above about 2000 MHz is shown above. Frequency modulation of the output frequency of the oscillator, or *afc* operation in a receiver, may be obtained by varying the negative voltage on the repeller electrode.

existing between the two grids of the buncher cavity. When the potential between the two grids is zero, the stream passes through without change in velocity. But when the potential between the two grids of the buncher is increasingly positive in the direction of electron motion, the velocity of the electrons in the beam is increased. Conversely, when the field becomes increasingly negative in the direction of the beam (corresponding to the other half-cycle of the exciting voltage from that which produced electron acceleration) the velocity of the electrons in the beam is decreased.

When the velocity-modulated electron beam reaches the drift space where there is no field, those electrons which have been sped up on one half-cycle overtake those immediately ahead which were slowed down on the other half-cycle. In this way, the beam electrons become bunched together. As the bunched groups pass through the two grids of the catcher cavity, they impart pulses of energy to these grids. The catcher-grid space is charged to different voltage levels by the passing electron bunches, and a corresponding oscillating field is set up in the catcher cavity. The catcher is designed to resonate at the frequency of the velocity-modulated beam, or at a harmonic of this frequency.

In the klystron amplifier, energy delivered by the buncher to the catcher grids is greater than that applied to the buncher cavity by the input signal. In the klystron oscillator a

feedback loop connects the two cavities. Coupling to either buncher or catcher is provided by small loops which enter the cavities by way of concentric lines.

The klystron is an electron-coupled device. When used as an oscillator, its output voltage is rich in harmonics. Klystron oscillators of various types afford power outputs ranging from less than 1 watt to many thousand watts. Operating efficiency varies between 5 and 50 percent. Frequency may be shifted to some extent by varying the beam voltage. Tuning is carried out mechanically in some klystrons by altering (by means of knob settings) the shape of the resonant cavity.

The Reflex Klystron The multicavity klystron as described in the preceding paragraphs is primarily used as a transmitting device since quite reasonable amounts of power are made available in its output circuit. However, for applications where a much smaller amount of power is required — power levels in the milliwatt range — for low-power transmitters, receiver local oscillators, etc., another type of klystron having only a single cavity is more frequently used.

The theory of operation of the single-cavity klystron is essentially the same as the multicavity type with the exception that the velocity-modulated electron beam, after hav-

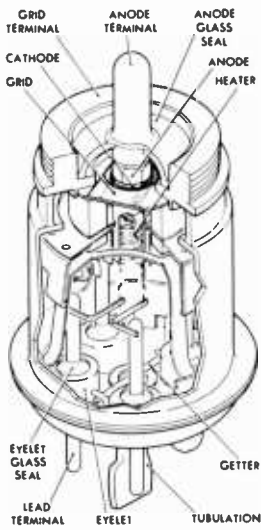

Figure 24

CUTAWAY VIEW OF WESTERN ELECTRIC 416-B/6280 VHF PLANAR TRIODE TUBE

The 416-B, designed by the Bell Telephone Laboratories is intended for amplifier or frequency multiplier service in the 4000 MHz region. Employing grid wires having a diameter equal to fifteen wavelengths of light, the 416-B has a transconductance of 50,000. Spacing between grid and cathode is .0005", to reduce transit-time effects. Entire tube is gold plated.

ing left the buncher cavity is reflected back into the area of the buncher again by a repeller electrode as illustrated in figure 23. The potentials on the various electrodes are adjusted to a value such that proper bunching of the electron beam will take place just as a particular portion of the velocity-modulated beam re-enters the area of the resonant cavity. Since this type of klystron has only one circuit it can be used only as an oscillator and not as an amplifier. Effective modulation of the frequency of a single-cavity klystron for f-m work can be obtained by modulating the repeller electrode voltage.

The Magnetron The magnetron is a *ubf* oscillator tube normally employed where very-high values of peak power or moderate amounts of average power are required in the range from perhaps 700 MHz to 30,000 MHz. Special magnetrons

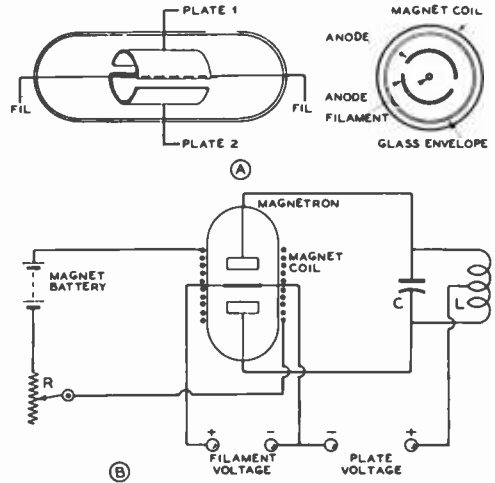

Figure 25

SIMPLE MAGNETRON OSCILLATOR

An external tank circuit is used with this type of magnetron oscillator for operation in the lower uhf range.

were developed for wartime use in radar equipment which had peak power capabilities of several million watts (megawatts) output at frequencies in the vicinity of 3000 MHz. The normal duty cycle of operation of these radar units was approximately 1/10 of one percent (the tube operated about 1/1000 of the time and rested for the balance of the operating period) so that the average power output of these magnetrons was in the vicinity of 1000 watts.

In its simplest form the magnetron tube is a filament-type diode with two half-cylindrical plates or anodes situated coaxially with respect to the filament. The construction is illustrated in figure 25A. The anodes of the magnetron are connected to a resonant circuit as illustrated in figure 25B. The tube is surrounded by an electromagnet coil which, in turn, is connected to a low-voltage d-c energizing source through a rheostat (R) for controlling the strength of the magnetic field. The field coil is oriented so that the lines of magnetic force it sets up are parallel to the axis of the electrodes.

Under the influence of the strong magnetic field, electrons leaving the filament are deflected from their normal paths and move in circular orbits within the anode cylinder. This effect results in a negative

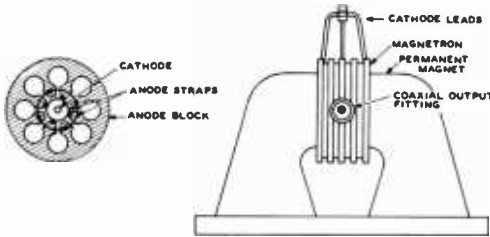

Figure 26

MODERN MULTICAVITY MAGNETRON

Illustrated is an external-anode strapped magnetron of the type commonly used in radar equipment for the 10-cm. range. An integral permanent magnet is shown in the righthand portion of the drawing, with the magnetron in place between the pole pieces of the magnet.

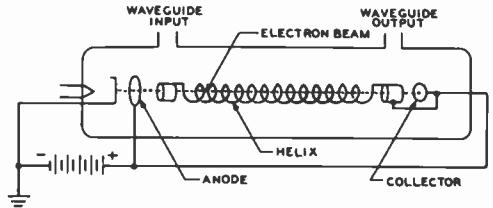

Figure 27

THE TRAVELING-WAVE TUBE

Operation of this tube is the result of interaction between the electron beam and wave traveling along the helix.

resistance which sustains oscillations. The oscillation frequency is very nearly the value determined by L and C . In other magnetron circuits, the frequency may be governed by the electron rotation, no external tuned circuits being employed. Wavelengths of less than 1 centimeter have been produced with such circuits.

More complex magnetron tubes employ no external tuned circuit, but utilize instead one or more resonant cavities which are integral with the anode structure. Figure 26 shows a magnetron of this type having a multicellular anode of eight cavities. It will be noted, also, that alternate cavities (which would operate at the same polarity when the tube is oscillating) are strapped together. Strapping was found to improve the efficiency and stability of high-power radar magnetrons. In most radar applications of magnetron oscillators, a powerful permanent magnet of controlled characteristics is employed to supply the magnetic field, rather than the use of an electromagnet.

The Traveling-Wave Tube

The *Traveling-Wave Tube* (figure 27) consists of a helix located within an evacuated envelope. Input and output terminations are affixed to each end of the helix. An electron beam passes through the helix and interacts with a wave traveling along the helix to produce broadband amplification at microwave frequencies.

When the input signal is applied to the gun end of the helix, it travels along the

helix wire at approximately the speed of light. However, the signal velocity measured along the axis of the helix is considerably lower. The electrons emitted by the cathode gun pass axially through the helix to the collector, located at the output end of the helix. The average velocity of the electrons depends on the potential of the collector with respect to the cathode. When the average velocity of the electrons is greater than the velocity of the helix wave, the electrons become crowded together in the various regions of retarded field, where they impart energy to the helix wave. A power gain of 100 or more may be produced by this tube.

4-8 The Cathode-Ray Tube

The *cathode-ray tube* is a special type of electron tube which permits the visual observation of electrical signals. It may be incorporated into an oscilloscope for use as a test instrument or it may be the display device for radar equipment or television.

Operation of the CRT

A cathode-ray tube always includes an *electron gun* for producing a stream of electrons, a *grid* for controlling the intensity of the electron beam, and a *luminescent screen* for converting the impinging electron beam into visible light. Such a tube always operates in conjunction with either a built-in or an external means for focusing the electron stream into a narrow beam, and a means for deflecting the electron beam in accordance with an electrical signal.

The main electrical difference between types of cathode-ray tubes lies in the means

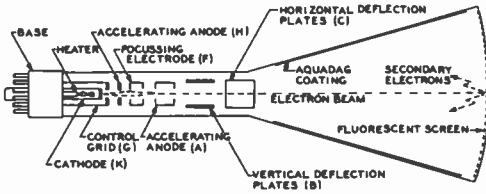

Figure 28

TYPICAL ELECTROSTATIC CATHODE-RAY TUBE

employed for focusing and deflecting the electron beam. The beam may be focused and/or deflected either electrostatically or magnetically, since a stream of electrons can be acted on either by an electrostatic or a magnetic field. In an electrostatic field the electron beam tends to be deflected toward the positive termination of the field (figure 28). In a magnetic field the stream tends to be deflected at right angles to the field. Further, an electron beam tends to be deflected so that it is normal (perpendicular) to the equipotential lines of an electrostatic field—and it tends to be deflected so that it is parallel to the lines of force in a magnetic field.

Large cathode-ray tubes used as *kinescopes* in television receivers usually are both focused and deflected magnetically. On the other hand, the medium-size CR tubes used in oscilloscopes and small television receivers usually are both focused and deflected electrostatically. Cathode-ray tubes for special applications may be focused magnetically and deflected electrostatically or vice versa.

There are advantages and disadvantages to both types of focusing and deflection. However, it may be stated that electrostatic deflection is much better than magnetic deflection when high-frequency waves are to be displayed on the screen; hence the almost universal use of this type of deflection for oscillographic work. When a tube is operated at a high value of accelerating potential so as to obtain a bright display on the face of the tube as for television or radar work, the use of magnetic deflection becomes desirable since it is relatively easier to deflect a high-velocity electron beam magnetically than electrostatically. An *ion trap* is required with magnetic deflection since the heavy negative ions emitted by the cathode are not materially deflected

by the magnetic field and would burn an *ion spot* in the center of the luminescent screen. With electrostatic deflection the heavy ions are deflected equally as well as the electrons in the beam so that an ion spot is not formed.

Construction of Electrostatic CRT The construction of a typical electrostatic-focus, electrostatic-deflection cathode-ray tube is illustrated in the pictorial diagram of figure 28. The *indirectly heated cathode* (K) releases free electrons when heated by the enclosed filament. The cathode is surrounded by a cylinder (G) which has a small hole in its front for the passage of the electron stream. Although this element is not a wire mesh as is the usual grid, it is known by the same name because its action is similar: it controls the electron stream when its negative potential is varied.

Next in order, is found the first *accelerating anode* (H) which resembles another disk or cylinder with a small hole in its center. This electrode is run at a high or moderately high positive voltage, to accelerate the electrons toward the far end of the tube.

The *focusing electrode* (F) is a sleeve which usually contains two small disks, each with a small hole.

After leaving the focusing electrode, the electrons pass through another *accelerating anode* (A) which is operated at a high positive potential. In some tubes this electrode is operated at a higher potential than the first accelerating electrode (H) while in other tubes both accelerating electrodes are operated at the same potential.

The electrodes which have been described up to this point constitute the *electron gun*, which produces the free electrons and focuses them into a slender, concentrated, rapidly traveling stream for projecting onto the viewing screen.

Electrostatic Deflection To make the tube useful, means must be provided for deflecting the electron beam along two axes at right angles to each other. The more common tubes employ *electrostatic deflection plates*, one pair to exert a force on the beam in the vertical plane and one pair to exert a force in the horizontal plane. These plates are designated as B and C in figure 28.

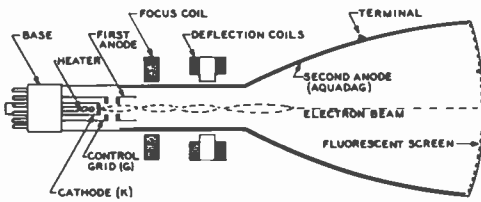

Figure 29

TYPICAL ELECTROMAGNETIC CATHODE-RAY TUBE

Standard oscilloscope practice with small cathode-ray tubes calls for connecting one of the B plates and one of the C plates together and to the high-voltage accelerating anode. With the newer three-inch tubes and with five-inch tubes and larger, all four deflection plates are commonly used for deflection. The *positive* high voltage is grounded, instead of the negative as is common practice in amplifiers, etc., in order to permit operation of the deflecting plates at a d-c potential at or near ground.

An *Aquadag* coating is applied to the inside of the envelope to attract any secondary electrons emitted by the fluorescent screen.

In the average electrostatic-deflection CR tube the spot will be fairly well centered if all four deflection plates are returned to the potential of the second anode (ground). However, for accurate centering and to permit moving the entire trace either horizontally or vertically to permit display of a particular waveform, horizontal- and vertical-centering controls usually are provided on the front of the oscilloscope.

After the spot is once centered, it is necessary only to apply a positive or negative voltage (with respect to ground) to one of the ungrounded or "free" deflector plates in order to move the spot. If the voltage is positive with respect to ground, the beam will be attracted toward that deflector plate. If it is negative, the beam and spot will be repulsed. The amount of deflection is directly proportional to the voltage (with respect to ground) that is applied to the free electrode.

With the larger-screen higher-voltage tubes it becomes necessary to place deflecting voltage on both horizontal and both vertical

plates. This is done for two reasons: First, the amount of deflection voltage required by the high-voltage tubes is so great that a transmitting tube operating from a high-voltage supply would be required to attain this voltage without distortion. By using push-pull deflection with two tubes feeding the deflection plates, the necessary plate-supply voltage for the deflection amplifier is halved. Second, a certain amount of defocusing of the electron stream is always present on the extreme excursions in deflection voltage when this voltage is applied only to one deflecting plate. When the deflecting voltage is fed in push-pull to both deflecting plates in each plane, there is no defocusing because the *average* voltage acting on the electron stream is zero, even though the *net* voltage (which causes the deflection) acting on the stream is twice that on either plate.

The fact that the beam is deflected by a magnetic field is important even in an oscilloscope which employs a tube using electrostatic deflection, because it means that precautions must be taken to protect the tube from the transformer fields and sometimes even the earth's magnetic field. This normally is done by incorporating a magnetic shield around the tube and by placing any transformers as far from the tube as possible, oriented to the position which produces minimum effect on the electron stream.

Construction of Electro- The electromagnetic
magnetic CRT cathode-ray tube al-
lows greater defini-
tion than does the electrostatic tube. Also,
electromagnetic definition has a number of
advantages when a rotating radial sweep is
required to give polar indications.

The production of the electron beam in an electromagnetic tube is essentially the same as in the electrostatic tube. The grid structure is similar, and controls the electron beam in an identical manner. The elements of a typical electromagnetic tube are shown in figure 29. The *focus coil* is wound on an iron core which may be moved along the neck of the tube to focus the electron beam. For final adjustment, the current flowing in the coil may be varied. A second pair of coils, the *deflection coils*, are mounted at right angles to each other around the neck

of the tube. In some cases, these coils can rotate around the axis of the tube.

Two *anodes* are used for accelerating the electrons from the cathode to the screen. The second anode is a graphite coating (*Aquadag*) on the inside of the glass envelope. The function of this coating is to attract any secondary electrons emitted by the fluorescent screen, and also to shield the electron beam.

In some types of electromagnetic tubes, a first, or *accelerating anode* is also used in addition to the *Aquadag*.

Electromagnetic Deflection A magnetic field will deflect an electron beam in a direction which is at right angles to both the direction of the field and the direction of motion of the beam.

In the general case, two pairs of deflection coils are used (figure 30). One pair is for horizontal deflection, and the other pair is for vertical deflection. The two coils in a pair are connected in series and are wound in such directions that the magnetic field flows from one coil, through the electron beam to the other coil. The force exerted on the beam by the field moves it to any point on the screen by application of the proper currents to these coils.

The Troce The human eye retains an image for about one-sixteenth second after viewing. In a CRT, the spot can be moved so quickly that a series of adjacent spots can be made to appear as a line, if the beam is swept over the path fast enough. As long as the electron beam strikes in a given place at least sixteen times a second, the spot will appear to the human eye as a source of continuous light with very little flicker.

Screen Materials— "Phosphors" At least five types of luminescent screen materials are commonly available on the various types of CR tubes commercially available. These screen materials are called *phosphors*; each of the five phosphors is best suited to a particular type of application. The P-1 phosphor, which has a green fluorescence with medium persistence, is almost invariably used for oscilloscope tubes for visual observation. The P-4 phosphor, with white fluorescence and medium

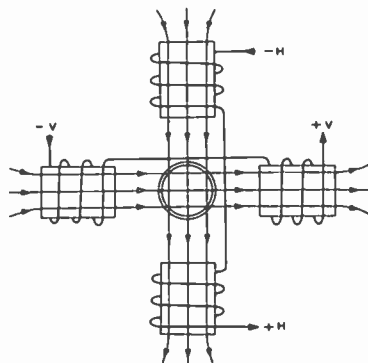

Figure 30

Two pairs of coils arranged for electromagnetic deflection in two directions.

persistence, is used on television viewing tubes (*Kinescopes*). The P-5 and P-11 phosphors, with blue fluorescence and very short persistence, are used primarily in oscilloscopes where photographic recording of the trace is to be obtained. The P-7 phosphor, which has a blue flash and a long-persistence greenish-yellow persistence, is used primarily for radar displays where retention of the image for several seconds after the initial signal display is required.

4-9 Gas Tubes

The space charge of electrons in the vicinity of the cathode in a diode causes the plate-to-cathode voltage drop to be a function of the current being carried between the cathode and the plate. This voltage drop can be rather high when large currents are being passed, causing a considerable amount of energy loss which shows up as plate dissipation.

Action of Positive Ions The negative space charge can be neutralized by the presence of the proper density of positive ions in the space between the cathode and anode. The positive ions may be obtained by the introduction of the proper amount of gas or a small amount of mercury into the envelope of the tube. When the voltage drop across the tube reaches the ionization potential of the gas or mercury vapor, the gas molecules will become ionized to form positive ions. The positive ions then tend to neutralize the space charge in the

vicinity of the cathode. The voltage drop across the tube then remains constant at the ionization potential of the gas, up to a current drain equal to the maximum emission capability of the cathode. The voltage drop varies between 10 and 20 volts, depending on the particular gas employed, up to the maximum current rating of the tube.

Mercury-Vapor Tubes Mercury-vapor tubes, although very widely used, have the disadvantage that they must be operated within a specific temperature range (25° to 70° C) in order that the mercury-vapor pressure within the tube shall be within the proper range. If the temperature is too low, the drop across the tube becomes too high causing immediate overheating and possible damage to the elements. If the temperature is too high, the vapor pressure is too high, and the voltage at which the tube will "flash back" is lowered to the point where destruction of the tube may take place. Since the ambient temperature range specified above is within the normal room temperature range, no trouble will be encountered under normal operating conditions. However, by the substitution of xenon gas for mercury it is possible to produce a rectifier with characteristics comparable to those of the mercury-vapor tube except that the tube is capable of operating over the range from approximately -70° to +90° C. The 3B25 rectifier is an example of this type of tube.

Thyratron Tubes If a grid is inserted between the cathode and plate of a mercury-vapor gaseous-conduction rectifier, a negative potential placed on the added element will increase the plate-to-cathode voltage drop required before the tube will ionize or "fire." The potential on the control grid will have no effect on the plate-to-cathode drop after the tube has ionized. However, the grid voltage may be adjusted to such a value that conduction will take place only over the desired portion of the cycle of the a-c voltage being impressed on the plate of the rectifier.

Voltage-Regulator Tubes In a glow-discharge gas tube the voltage drop across the electrodes remains constant over a wide range of current

passing through the tube. This property exists because the degree of ionization of the gas in the tube varies with the amount of current passing through the tube. When a large current is passed, the gas is highly ionized and the internal impedance of the tube is low. When a small current is passed, the gas is lightly ionized and the internal impedance of the tube is high. Over the operating range of the tube, the product (*IR*) of the current through the tube and the internal impedance of the tube is very nearly constant. Examples of this type of tube are the OB2, OC2, and VR-150.

Vacuum-Tube Classification Vacuum tubes are grouped into three major classifications: commercial, ruggedized, and premium (or reliable). Any one of these three groups may also be further classified for military duty (MIL spec. or JAN classification). To qualify for MIL classification, sample lots of the particular tube must have passed special qualification tests at the factory. It should not be construed that a MIL-type tube is better than a commercial tube, since some commercial tests and specifications are more rigid than the corresponding MIL specifications. The MIL stamped tube has merely been accepted under a certain set of conditions for military service.

Ruggedized or Premium Tubes Radio tubes are being used in increasing numbers for industrial applications, such as computing and control machinery, and in aviation and marine equipment. When a tube fails in a home radio receiver, it is merely inconvenient, but a tube failure in industrial applications may bring about stoppage of some vital process, resulting in financial loss, or even danger to life.

To meet the demands of these industrial applications, a series of tubes was evolved incorporating many special features designed to ensure a long and predetermined operating life, and uniform characteristics among similar tubes. Such tubes are known as *ruggedized* or *premium* tubes. Early attempts to select reliable specimens of tubes from ordinary stock tubes proved that in the long run the selected tubes were no better than tubes picked at random. Long life and ruggedness had to be built into the tubes by means of

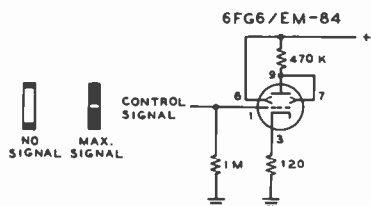

Figure 31

SCHEMATIC REPRESENTATION OF "MAGIC EYE" TUBE

proper choice and 100% inspection of all materials used in the tube, by critical processing inspection and assembling, and by conservative ratings of the tube.

Pure tungsten wire is used for heaters in preference to alloys of lower tensile strength. Nickel tubing is employed around the heater wires at the junction to the stem wires to reduce breakage at this point. Element structures are given extra supports and bracing. Finally, all tubes are given a 50-hour test run under full operating conditions to eliminate early failures. When operated within their ratings, ruggedized or premium tubes should provide a life well in excess of 10,000 hours.

Ruggedized tubes will withstand severe impact shocks for short periods, and will operate under conditions of vibration for many hours. The tubes may be identified in many cases by the fact that their nomenclature includes a "W" in the type number, as in 807W, 5U4W, etc. Some ruggedized tubes are included in the "5000" series nomenclature. The 5654 is a ruggedized version of the 6AK5, the 5692 is a ruggedized version of the 6SN7, etc.

4-10 Miscellaneous Tube Types

Electron-Ray Tubes The electron-ray tube or *magic eye* contains two sets of elements, one of which is a triode amplifier and the other a cathode-ray indicator. The plate of the triode section is connected to the ray-control electrodes (figure 31), so that as the plate voltage varies in accordance with the applied signal, the voltage on the ray-control electrode also varies. The electrons which strike the anode cause it to fluoresce, or give off light, so

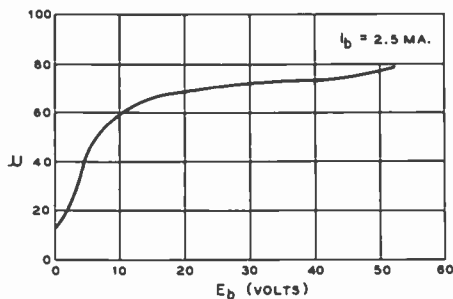

Figure 32

AMPLIFICATION FACTOR OF TYPICAL STANDARD TUBE DROPS RAPIDLY AS PLATE VOLTAGE IS DECREASED BELOW 20 VOLTS

that the deflection caused by the ray-control electrodes, which prevents electrons from striking part of the anode, produces an electrical shadow on the fluorescent anode. The size of this shadow is determined by the voltage on the ray electrodes. When these electrodes are at the same potential as the fluorescent anode, the shadow disappears; if the ray electrode is less positive than the anode, a shadow appears, the length of which is proportional to the voltage on the ray electrodes.

Controlled Warmup Tubes Series heater strings are employed in a-c/d-c radio receivers and television sets to reduce the cost, size, and weight of the equipment. Voltage surges of great magnitude occur in series-operated filaments because of variations in the rate of warm-up of the various tubes. As the tubes warm up, the heater resistance changes. This change is not the same between tubes of various types, or even between tubes of the same type made by different manufacturers. Some 6-volt tubes show an initial surge as high as 9 volts during warm-up, while slow-heating tubes such as the 25BQ6 are underheated during the voltage surge on the 6-volt tubes.

Standardization of heater characteristics in a new group of tubes designed for series heater strings has eliminated this trouble. The new tubes have either 600 ma or 400 ma heaters, with a controlled warm-up time of approximately 11 seconds. The 5U8, 6CG7, and 12BH7-A are examples.

Semiconductor Devices

One of the earliest detection devices used in radio was the galena crystal, a crude example of a *semiconductor*. More modern examples of semiconductors are the selenium and silicon rectifiers, the germanium diode, and numerous varieties of the transistor. All of these devices offer the interesting property of greater resistance to the flow of electrical current in one direction than in the opposite direction. Typical conduction curves for some semiconductors are shown in figure 1. The *transistor*, a three-terminal device, moreover, offers current amplification and may be used for a wide variety of control functions including amplification, oscillation, and frequency conversion.

Semiconductors have important advantages over other types of electron devices. They are very small, light and require no filament voltage. In addition, they consume very little power, are rugged, and can be made impervious to many harsh environmental conditions. Transistors are capable of usable amplification into the uhf region and provide hundreds of watts of power capacity at the lower frequencies.

Common transistors are current-operated devices whereas vacuum tubes are voltage-operated devices so that direct comparisons between the two may prove to be misleading, however economic competition exists between the two devices and the inexpensive and compact transistor is rapidly taking over some of the functions previously reserved for the more expensive vacuum tube.

5-1 Atomic Structure of Germanium and Silicon

Since the mechanism of conduction of a semiconductor device is different from that of a vacuum tube, it is well to briefly review the atomic structure of various materials used in the manufacture of transistors and diodes.

It was stated in an earlier chapter that the electrons in an element having a large atomic number are conveniently pictured as being grouped into rings, each ring having a definite number of electrons. Atoms in which these rings are completely filled are termed *inert gases*, of which helium and argon are examples. All other elements have one or more incomplete rings of electrons. If the incomplete ring is loosely bound, the electrons may be easily removed, the element is called *metallic*, and is a conductor of electric current. Copper and iron are examples of conductors. If the incomplete ring is tightly bound, with only a few electrons missing, the element is called *non-metallic*, and is an insulator (nonconductor) to electric current. A group of elements, of which germanium, gallium, and silicon are examples, fall between these two sharply defined groups and exhibit both metallic and nonmetallic characteristics. Pure germanium or silicon may be considered to be a good insulator. The addition of certain impurities in carefully controlled amounts to the pure

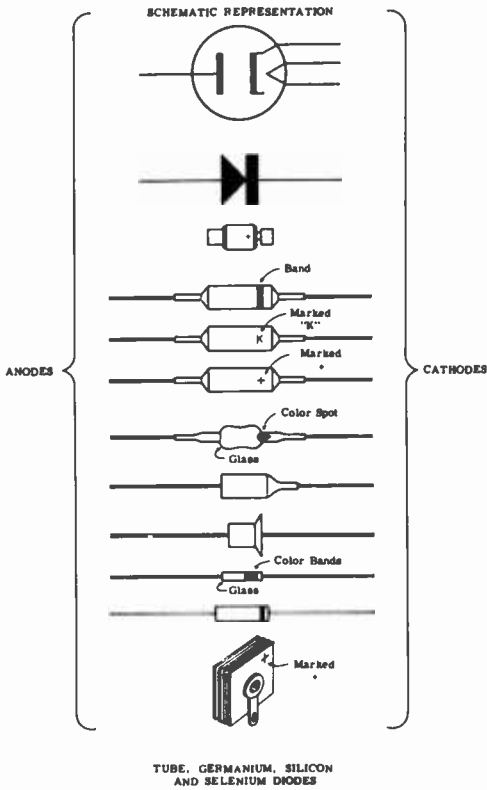

element will alter the conductivity of the material. In addition, the choice of the impurity can change the direction of conductivity through the element, some impurities increasing conductivity to positive potentials and others increasing conductivity to negative potentials. Early transistors were mainly made of germanium but most modern transistors possessing power capability are made of silicon. Experimental transistors are being made of gallium arsenide which combines some of the desirable features of both germanium and silicon.

Both germanium and silicon may be "grown" in a diamond lattice crystal configuration, the atoms being held together by bonds involving a shared pair of electrons (figure 2). Electrical conduction within the crystal takes place when a bond is broken, or when the lattice structure is altered to obtain an excess electron by the addition of an impurity. When the impurity is added, it may have more or less loosely held electrons than the original atom, thus allowing an electron to become available for conduction, or creating a vacancy, or *hole*, in the shared electron bond. The presence of a hole encourages the flow of electrons and may be considered to have a positive charge, since it represents the absence of an electron. The hole behaves, then, as if it were an electron, but it does not exist outside the crystal.

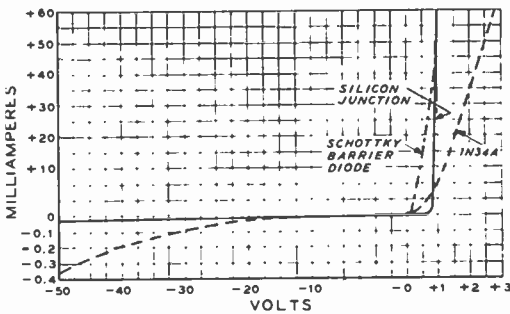

Figure 1

DIODE CHARACTERISTICS AND CODING

The semiconductor diode offers greater resistance to the flow of current in one direction than in the opposite direction. Note expansion of negative current and positive voltage scales. Diode coding is shown above, with notations usually placed on cathode (positive) end of unit.

5-2 Mechanism of Conduction

There exist in semiconductors both negatively charged electrons and absence of electrons in the lattice (holes), which behave as though they had a positive electrical charge equal in magnitude to the negative charge on the electron. These electrons and holes drift in an electrical field with a velocity which is proportional to the field itself:

$$V_{dh} = \mu_h E$$

where,

V_{dh} equals drift velocity of hole,
 E equals magnitude of electric field,
 μ_h equals mobility of hole.

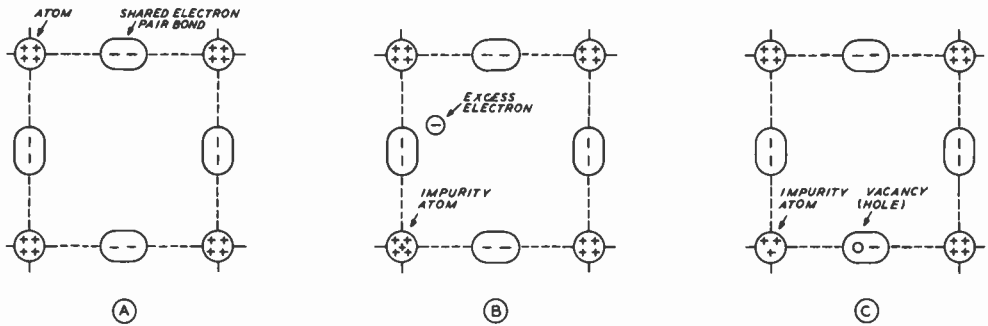

Figure 2

SEMICONDUCTOR CRYSTAL LATTICE

Silicon and germanium lattice configuration made up of atoms held by shared pair of electrons. Conduction takes place when bond is altered to free (B) or to create electron vacancy or conducting "hole" (C).

In an electric field the holes will drift in a direction opposite to that of the electron and with about one-half the velocity, since the hole mobility is about one-half the electron mobility. A sample of a semiconductor, such as germanium or silicon, which is both chemically pure and mechanically perfect will contain in it approximately equal numbers of holes and electrons and is called an *intrinsic* semiconductor. The intrinsic resistivity of the semiconductor depends strongly on the temperature, being about 50 ohm/cm for germanium at room temperature. The intrinsic resistivity of silicon is about 65,000 ohm/cm at the same temperature.

If, in the growing of the semiconductor crystal, a small amount of an impurity, such as phosphorous is included in the crystal, each atom of the impurity contributes one free electron. This electron is available for conduction. The crystal is said to be *doped* and has become electron-conducting in nature and is called *N (negative)-type* silicon. The impurities which contribute electrons are called *donors*. N-type silicon has better conductivity than pure silicon in one direction, and a continuous stream of electrons will flow through the crystal in this direction as long as an external potential of the correct polarity is applied across the crystal.

Other impurities, such as boron add one hole to the semiconducting crystal by accepting one electron for each atom of impurity, thus creating additional holes in the

semiconducting crystal. The material is now said to be hole-conducting, or *P (positive)-type* silicon. The impurities which create holes are called *acceptors*. P-type silicon has better conductivity than pure silicon in one direction. This direction is opposite to that of the N-type material. Either the N-type or the P-type silicon is called *extrinsic* conducting type. The doped materials have lower resistivities than the pure materials, and doped semiconductor material in the resistivity range of .01 to 10 ohm/cm is normally used in the production of transistors.

The electrons and holes are called *carriers*; the electrons are termed *majority carriers*, and the holes are called *minority carriers*.

5-3 The PN Junction

The semiconductor diode is a *PN junction*, or *junction diode* having the general electrical characteristic of figure 1 and the electrical configuration of figure 3. The anode of the junction diode is always positive-type (P) material while the cathode is always negative-type (N) material. Current flow occurs when the P-anode is positive with respect to the N-cathode. This state is termed *forward bias*. Blocking occurs when

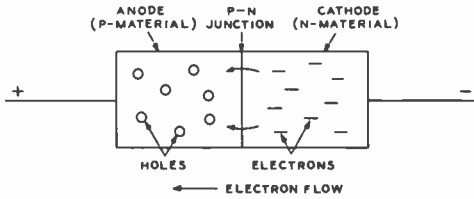

Figure 3

PN JUNCTION DIODE

P-type and N-type materials form junction diode. Current flows when P anode is positive with respect to the N cathode (forward bias). Electrons and holes are termed carriers, with holes behaving as though they have a positive charge.

the P-anode is negative with respect to the N-cathode. This is termed *reverse bias*. When no external voltage is applied to the PN junction, the energy barrier created at the junction prevents diffusion of carriers across the junction. Application of a positive potential to the P-anode effectively reduces the energy barrier, and application of a negative potential increases the energy barrier, limiting current flow through the junction.

In the forward-bias region shown in figure 1, current rises rapidly as the voltage is increased, whereas in the reverse-bias region current is much lower. The junction, in other words is a high-resistance element in the reverse-bias direction and a low-resistance element in the forward-bias direction.

Junction diodes are rated in terms of average and peak-inverse voltage in a given environment, much in the same manner as thermionic rectifiers. Unlike the latter, however, a small *leakage current* will flow in the reverse-biased junction diode because of a few hole-electron pairs thermally generated in the junction. As the applied inverse voltage is increased, a potential will be reached at which the leakage current rises abruptly at an *avalanche voltage* point. An increase in inverse voltage above this value can result in the flow of a large reverse current and the possible destruction of the diode.

Maximum permissible forward current in the junction diode is limited by the voltage drop across the diode and the heat-dissipation capability of the diode structure. Power diodes are often attached to the chassis of

the equipment by means of a *heat-sink* to remove excess heat from the small junction.

Silicon diode rectifiers exhibit a forward voltage drop of 0.4 to 0.8 volts, depending on the junction temperature and the impurity concentration of the junction. The forward voltage drop is not constant, increasing directly as the forward current increases. Internal power loss in the diode increases as the square of the current and thus increases rapidly at high current and temperature levels.

After a period of conduction, a silicon rectifier requires a finite time interval to elapse before it may return to the reverse-bias condition. This *reverse recovery time* imposes an upper limit on the frequency at which a silicon rectifier may be used. Operation at a frequency above this limit results in overheating of the junction and possible destruction of the diode because of the power loss during the period of recovery.

The Zener Diode The *zener diode* (reference diode) is a PN junction that can be used

as a constant-voltage reference, or as a control element. It is a silicon element operated in the reverse-bias avalanche breakdown region (figure 4). The break from nonconduction to conduction is very sharp and at applied voltages greater than the breakdown point, the voltage drop across the diode junction becomes essentially con-

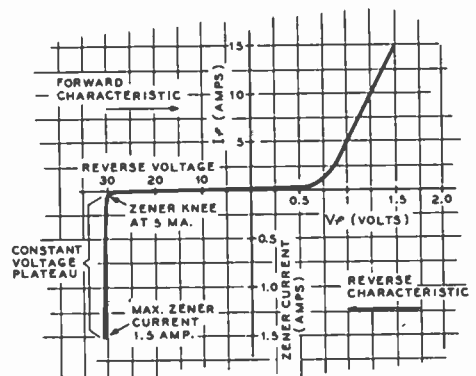

Figure 4

ZENER-DIODE CHARACTERISTIC CURVE

Between zener knee and point of maximum current, the zener voltage is essentially constant at 30 volts. Units are available with zener voltages from approximately 4 to 200.

stant for a relatively wide range of currents. This is the *zener control region*. Zener diodes are available in ratings to 50 watts, with zener voltages ranging from approximately 4 volts to 200 volts.

Thermal dissipation is obtained by mounting the zener diode to a heat sink composed of a large area of metal having free access to ambient air.

The zener diode has no ignition potential as does a gas regulator tube, thus eliminating the problems of relaxation oscillation and high firing potential, two ailments of the gas tube. Furthermore, the zener regulator or combinations can be obtained for almost any voltage or power range, while the gas tubes are limited to specific voltages and restricted current ranges.

Zener Diode Applications The zener diode may be employed as a shunt regulator (figure 5A) in the manner of a gas regulator tube. Two zener diodes may be used in the circuit of illustration B to supply very low values of regulated voltage. Two opposed zener diodes provide a-c clipping of both halves of the cycle (illustration C) and may be used as an audio clipper in speech amplifiers. Zener diodes may also be used to protect meter movements since they provide a very low resistance shunt across the movement when the applied voltage exceeds a certain critical value. The zener diode can be used to regulate a.c. as well as d.c. and so may be used to regulate filament voltage or to supply regulated bias for audio or r-f amplifiers, providing stable bias with a varying diode current (figure 6A). The zener diode may also be used with transistors (figure 6B), the diode replacing the usual emitter resistor to provide controlled emitter bias. Sufficient current must flow through the zener element to ensure operation in the breakdown region.

Junction Capacitance The PN junction possesses capacitance as the result of opposite electric charges existing on the sides of the barrier. Junction capacitance changes with applied voltage, as shown in figure 7. Reverse-biased diodes may be used as d-c voltage-controlled variable capacitors for frequency control of remote



FIGURE 5
A-ZENER DIODE FUNCTIONS AS VOLTAGE REGULATOR OVER RANGE OF CONSTANT VOLTAGE PLATEAU.
B-TWO ZENER DIODES OF DIFFERENT VOLTAGE CAN PROVIDE SMALL REGULATED VOLTAGE.
C-OPPOSED ZENER DIODES CLIP BOTH HALVES OF CYCLE OF A-C WAVE.

Figure 5

ZENER DIODES USED AS VOLTAGE REGULATORS AND CLIPPERS

circuits or as highly efficient frequency multipliers in solid-state vhf equipment, as described in the next section.

The voltage-variable capacitor (*Varactor* or *Varicap*) is generally made of a silicon junction having a special impurity concentration to enhance the capacitance variation and to minimize series resistance losses. A typical frequency-control circuit employing a varicap junction capacitance is shown in figure 8.

The Varactor The varactor is well suited for harmonic generation and

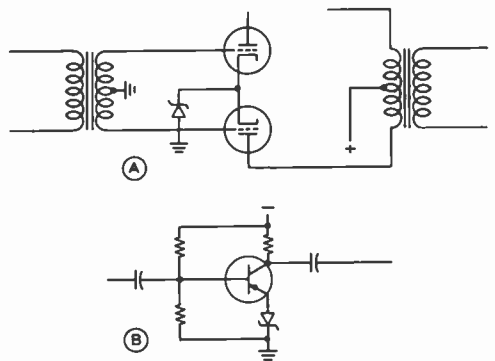

Figure 6

ZENER-REGULATED BIAS SUPPLY

A-Zener bias for class-B modulator providing positive cathode bias. B-Zener diode for PNP transistor providing negative emitter bias.

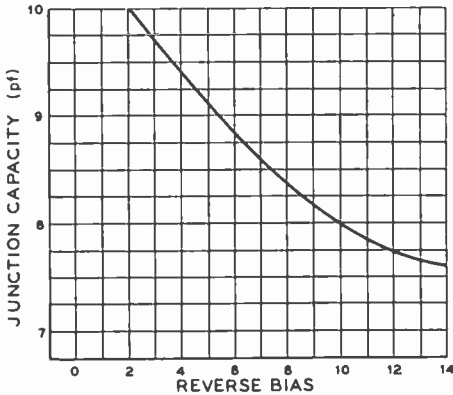

Figure 7

JUNCTION CAPACITANCE VARIATION WITH RESPECT TO REVERSE VOLTAGE

may be used as an r-f multiplication device. Frequency multiplication in the vhf and uhf regions makes use of varactors because high conversion efficiency and relatively large power-handling capability may be achieved at moderate cost with minimum complexity.

Basic varactor circuits which can be used for doubling, tripling, and quadrupling are shown in figure 9. The doubler consists of a varactor coupled to two high-Q, series-tuned circuits. The input circuit is resonant

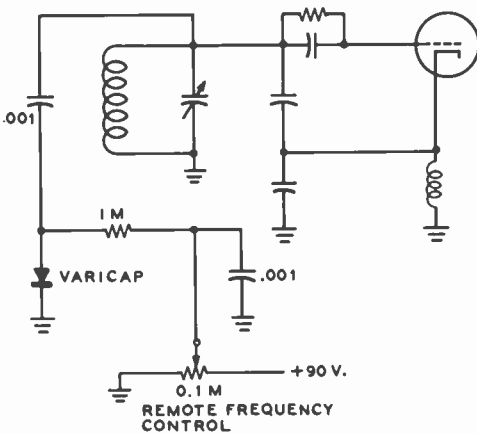

Figure 8

VOLTAGE VARIABLE JUNCTION DIODE MAY BE USED FOR REMOTE FREQUENCY CONTROL OF VARIABLE OSCILLATOR

at the fundamental (driving) frequency and the other is resonant at the harmonic (output) frequency.

The tripler and quadrupler circuits are similar to the doubler configuration with the exception that an additional *idler loop*, resonant with the varactor capacitance at the second-harmonic frequency, is added in shunt with the varactor. The idler loop boosts conversion efficiency by producing additional harmonic output from the beating action between the fundamental and second harmonics. Doubling or tripling efficiency of a typical vhf varactor multiplier may run from 50 to 70 percent.

Varactors are capable of providing output power of over 25 watts at 1 GHz, and several watts at 5 GHz. Experimental varactors have been used for frequency multiplication to over 20 GHz, with power capabilities in the milliwatt region.

The Tunnel Diode The *tunnel diode* is a two-terminal junction that exhibits pronounced negative-resistance characteristics over a portion of the operating range. The proper combination of impurities in the semiconductor material in this device allows the diode to rest in a reverse-breakdown condition at a slight forward-bias point. Thus, over a small voltage range, the tunnel diode conducts heavily as the voltage becomes more negative. The negative conductance generates energy, and this action is the basis of the *resistance amplifier* (or oscillator) circuit making use of the tunnel diode (figure 10).

Point Contact and Other Diodes A rectifying junction may be made of a metal "whisker" touching a very small semiconductor die (plural, dice). When properly assembled, the die injects electrons into the metal. The contact areas exhibits extremely low capacitance and *point contact diodes* (such as the 1N21) are widely used as microwave mixers, having noise figures ranging up to 5 db at 3 GHz.

Step recovery and *snap-off* diodes exhibit rapid recovery time and are used in pulse operation or high-order harmonic generation. *PIN diodes* are special units having an intrinsic junction and are useful as charge-storage diodes for harmonic generation. *Photo-*

todiodes are light-sensitive junctions which pass forward current when illuminated, and *laser diodes* emit visible or infrared light when biased in the reverse direction.

SCR Devices The *thyristor*, or *silicon controlled rectifier (SCR)* is a three-terminal, three-junction semiconductor, which could be thought of as a solid-state thyatron. The SCR will conduct high current in the forward direction with low voltage drop, presenting a high impedance in the reverse direction. The three terminals (figure 11) of an SCR device are *anode*, *cathode* and *gate*. Without gate current the SCR is an open switch in either direction. Sufficient gate current will close the switch in the forward direction only. Forward conduction will continue even with gate

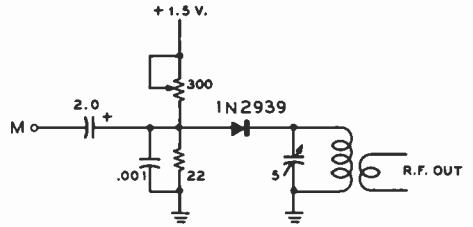

Figure 10

TUNNEL DIODE OSCILLATOR FOR 50-MHZ. MODULATION MAY BE APPLIED AT "M"

current removed until anode current is reduced below a critical value. At this point the SCR again blocks open. The SCR is therefore a high-speed unidirectional switch capable of being latched on in the forward direction.

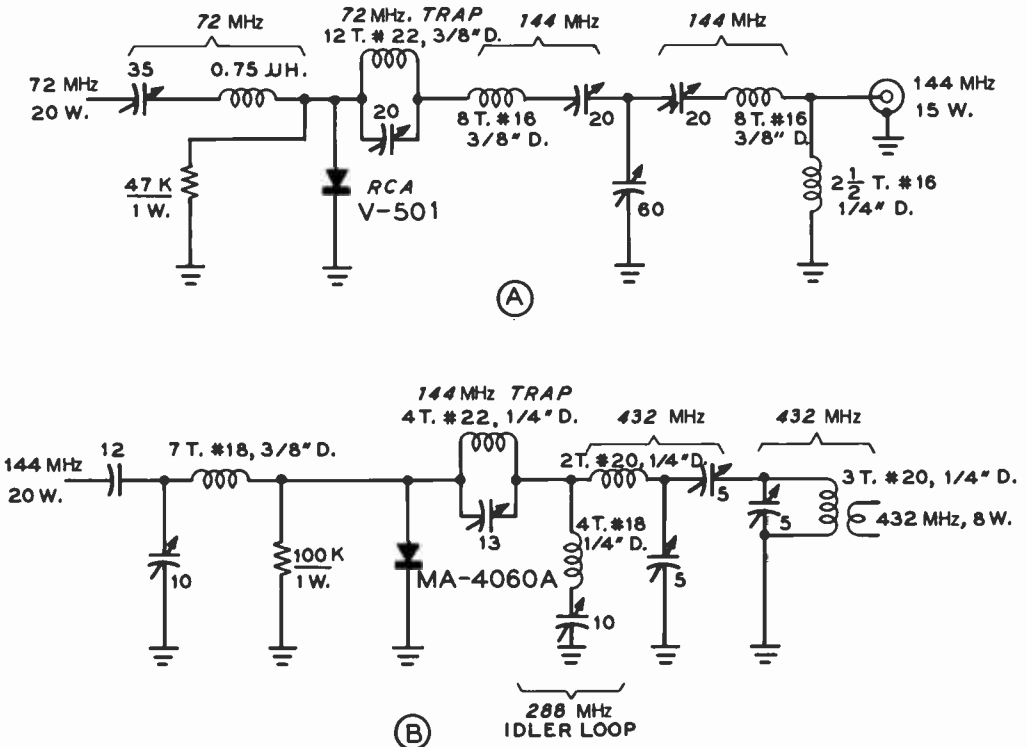

Figure 9

BASIC VARACTOR DOUBLING AND TRIPLING CIRCUITS

If "step-recovery" diode is used, idler loop may be omitted.



Figure 11

THE SILICON CONTROLLED RECTIFIER

This three-terminal semiconductor is an open switch until it is triggered in the forward direction by the gate element. Conduction will continue until anode current is reduced below a critical value.

The gate signal used to trigger an SCR may be an a-c wave, and the SCR may be used for dimming lights or speed control of small a-c universal series-wound motors,

such as those commonly used in power tools. Several power-control circuits using SCR devices and *triacs* (bidirectional triode thyristors) are shown in figure 12.

Thermal Considerations for Semiconductors

Semiconductor devices have ratings which are based on thermal considerations similar to other electronic devices. The majority of power lost in semiconductors is lost internally and within a very small volume of the device. Heat generated by these losses must flow outward to some form of *heat exchanger* in order to hold junction temperature to a reasonable degree. The largest amount of heat flows out through the case and mounting stud of the semiconductor and thence through the heat exchanger into the air. The heat exchanger (or *heat sink*) must be in intimate contact with the case or leads of the semiconductor to achieve maximum uniform contact and maximum heat transfer. The matching surfaces are often lubricated with a substance having good thermal conductivity to reduce oxides or galvanic products from forming on the surfaces (*Dow-Corning Silicone Grease #200* is often used).

Care must be exercised in the contact between dissimilar metals when mounting

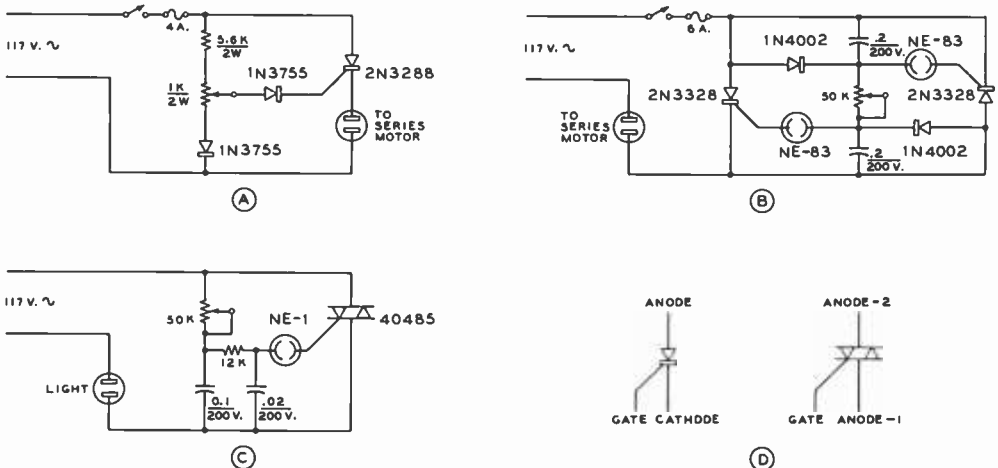

Figure 12

SCR CIRCUITS FOR MOTOR OR LIGHT CONTROL

A— Half-wave control circuit for series motor or light. B— Full-wave control circuit for series motor or light. C— Triac control light circuit. D— Symbols for SCR and Triac units.

semiconductor devices, otherwise electrolytic action may take place at the joint, with subsequent corrosion of one or more surfaces. Many rectifiers come with plated finishes to provide a nonactive material to be placed in contact with the heat sink.

When it is necessary to electrically insulate the case of the semiconductor from the heat sink, a thin mica washer may be placed between the device and the heat sink after lubricating the surfaces with a thermal lubricant.

5-4 The Transistor

The decisive event in the creation of the modern semiconductor was the invention of the *transistor* in late 1947. In the last decade semiconductor devices have grown prodigiously in variety, complexity, power capability, and speed of operation. The transistor is a solid-state device having gain properties previously found only in vacuum tubes. The elements germanium and silicon are the principal materials exhibiting the proper semiconducting properties which permit their application in transistors. However, other semiconducting materials, including the compounds indium, antimony, and lead sulfide, have been used experimentally in the production of transistors.

Classes of Transistors Thousands of type numbers of transistors exist, belonging to numerous families of construction and use. The large classes of transistors, based on manufacturing processes are:

Point Contact Transistor—The original transistor was of this class and consisted of *emitter* and *collector* electrodes touching a small block of germanium called the *base*. The base could be either N-type or P-type material and was about .05" square. Because of the difficulty in controlling the characteristics of this fragile device, it is now considered obsolete.

Grown Junction Transistor—Crystals made by this process are grown from molten germanium or silicon in such a way as to have the closely spaced junctions imbedded in the wafer. The impurity material is changed during the growth of the crystal to produce either PNP or NPN ingots,

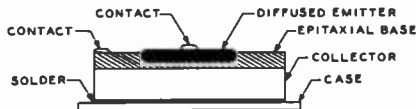

Figure 13

EPITAXIAL TRANSISTOR

Epitaxial, dual-epitaxial and overlay transistors are grown on semiconductor wafer in a lattice structure. After fabrication, individual transistors are separated from wafer and mounted on headers. Connector wires are bonded to metalized regions and unit is sealed in an inclosure.

which are then sliced into individual wafers. Junction transistors may be subdivided into *grown junction*, *alloy junction*, or *drift field* types. The latter type transistor is an alloy junction device in which the impurity concentration is contained within a certain region of the base in order to enhance the high-frequency performance of the transistor.

Diffused Junction Transistor—This class of semiconductor has enhanced frequency capability and the manufacturing process has facilitated the use of silicon rather than germanium, which aids the power capability of the unit. Diffused junction transistors may be subdivided into *single diffused* (homo-taxial), *double diffused*, *double diffused planar* and *triple diffused planar* types.

Epitaxial Transistors—These junction transistors are grown on a semiconductor wafer and photolithographic processes are used to define emitter and base region during growth. The units may be subdivided into *epitaxial-base*, *epitaxial-layer*, and *overlay* transistors. A representation of an epitaxial-layer transistor is shown in figure 13.

Field-Effect Transistors—Developed in the last decade from experiments conducted over forty years ago, the *field-effect (FET) transistor* may be expected to replace many more common transistor types. This majority carrier device is discussed in a later section of this Handbook.

Manufacturing techniques, transistor end-use, and patent restrictions result in a multitude of transistors, most of which fall into the broad groups discussed previously. Transistors, moreover, may be grouped in families wherein each member of the family is a unique type, but subtle differences exist

between members in the matter of end-use, gain, capacitance, mounting, case, leads, breakdown-voltage characteristics, etc. The differences are important enough to warrant individual type identification of each member. In addition, the state of the art permits transistor parameters to be economically designed to fit the various equipment, rather than designing the equipment around available transistor types. This situation results in a great many transistor types having nearly identical general characteristics. Finally, improved manufacturing techniques may "obsolete" a whole family of transistors with a newer, less-expensive family. It is recommended, therefore, that the reader refer to one of the various transistor substitution manuals for up-to-date guidance in transistor classification and substitution.

Transistor Nomenclature Semiconductors are generally divided into product groups classified as "entertainment", "industrial," and "military." The latter classifications often call for multiple testing, tighter tolerances, and quality documentation; and transistors from the same production line having less rigorous specifications often fall into the first, and least-expensive, category. Semiconductors are type numbered by several systems. The oldest standard is the JEDEC system. The first number of the identifier establishes the number of junctions (1 = diode, 2 = triode, 3 = tetrode): the letter *N* stands for a semiconductor, followed by a sequential number under which the device was registered.

European manufacturers employ an identifier consisting of a type number composed of two or three letters followed by two or three numbers, the letters indicating the

type of transistor and use and the numbers indicating the sequential number in the particular classification. Japanese transistors are usually identified by the code 2S, followed by an identifying letter and sequential number. In addition to these generally recognized codes, numerous codes adapted by individual manufacturers are also in use.

The Junction Transistor The junction transistor is fabricated in many forms, with the planar silicon type providing the majority of units. A pictorial equivalent of a silicon planar power transistor is shown in figure 14. In this type of transistor the emitter and base junctions are often formed by a photolithographic process in selected areas of the silicon dice. Many variations of this technique and design are in use.

The transistor has three essential actions which collectively are called *transistor action*. These are: minority carrier injection, transport, and collection. Fig. 15 shows a simplified drawing of a PNP junction-type transistor, which can illustrate this collective action. The PNP transistor consists of a piece of N-type silicon on opposite sides of which a layer of P-type material has been grown by the fusion process. Terminals are connected to the two P-sections and to the N-type base. The transistor may be considered as two PN junction rectifiers placed in close juxtaposition with a semiconductor crystal coupling the two rectifiers together. The left-hand terminal is biased in the forward (or conducting) direction and is called the *emitter*. The right-hand terminal is biased in the back (or

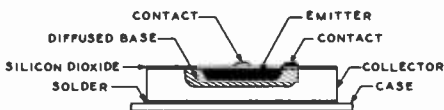

Figure 14

DIFFUSED JUNCTION TRANSISTOR

Emitter and base junctions are diffused into same side of semiconductor wafer which serves as collector. Junction heat is dissipated through solder joint between collector and package.

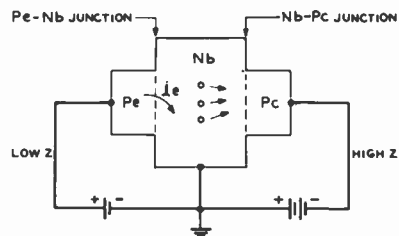

Figure 15

PICTORIAL EQUIVALENT OF PNP JUNCTION TRANSISTOR

reverse) direction and is called the *collector*. The operating potentials are chosen with respect to the *base terminal*, which may or may not be grounded. If an NPN transistor is used in place of the PNP, the operating potentials are reversed.

The P_e-N_b junction on the left is biased in the forward direction and holes from the P_e region are injected into the N_b region, producing therein a concentration of holes substantially greater than normally present in the material. These holes travel across the base region toward the collector, attracting neighboring electrons, finally increasing the available supply of conducting electrons in the collector loop. As a result, the collector loop possesses lower resistance whenever the emitter circuit is in operation. In junction transistors this *charge transport* is by means of diffusion wherein the charges move from a region of high concentration to a region of lower concentration at the collector. The collector, biased in the opposite direction, acts as a *sink* for these holes, and is said to collect them.

Alpha It is known that any rectifier biased in the forward direction has a very low internal impedance, whereas one biased in the back direction has a very high internal impedance. Thus, current flows into the transistor in a low-impedance circuit, and appears at the output as current flowing in a high-impedance circuit. The ratio of a change in d-c collector current to a change in emitter current is called the *current amplification*, or *alpha*:

$$\alpha = \frac{i_c}{i_e}$$

where,

- α equals current amplification,
- i_c equals change in collector current,
- i_e equals change in emitter current.

Values of alpha up to 3 or so may be obtained in commercially available point-contact transistors, and values of alpha up to about 0.999 are obtainable in junction transistors.

Beta The ratio of change in d-c collector current a change in base current (i_b) is a measure of amplification, or *beta*:

$$\beta = \frac{\alpha}{1 - \alpha} = \frac{i_c}{i_b}$$

Values of beta run to 100 or so in inexpensive junction transistors. The static d-c forward current gain of a transistor in the common-emitter mode is termed the *d-c beta* and may be designated β_F or h_{FE} .

Cutoff Frequencies The *alpha cutoff frequency* (f_{α}) of a transistor is that frequency at which the grounded-base current gain has decreased to 0.7 of the gain obtainable at 1 kHz. For audio transistors the alpha cutoff frequency is about 1 MHz. For r-f and switching transistors the alpha cutoff frequency may be 50 MHz or higher. The upper frequency limit of operation of the transistor is determined by the small but finite time it takes the majority carriers to move from one electrode to the other.

The *beta cutoff frequency* (f_{β}) is that frequency at which the grounded-emitter current gain has decreased to 0.7 of the gain obtainable at 1 kHz. *Transconductance cutoff frequency* (f_{gm}) is that frequency at which the transconductance falls to 0.7 of that value obtainable at 1 kHz. The *maximum frequency of oscillation* (f_{max}) is that frequency at which the maximum power gain of the transistor drops to unity.

Various internal time constants and transit times limit the high-frequency response of the transistor and these limitations are summarized in the *gain-bandwidth product* (f_t), which is identified by the frequency at

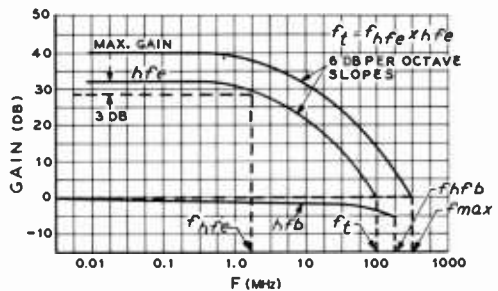

Figure 16
GAIN-BANDWIDTH CHART FOR
TYPICAL H-F TRANSISTOR

which the beta current gain drops to unity. These various cutoff frequencies and the gain-bandwidth products are shown in figure 16.

The Transition Region A useful rule common to both PNP and NPN transistors is: *moving the base potential toward the collector voltage point turns the transistor on, while moving the base potential away from the collector voltage point turns the transistor off.* When fully on, the transistor is said to be *saturated*. When fully off, the transistor is said to be *cut off*. The region between these two extremes is termed the *transition region*. A transistor may be used as a switch by simply biasing the base-emitter circuit on and off. Adjusting the base-emitter bias to some point in the transition region will permit the transistor to act as a signal amplifier. For such operation, base-emitter d-c bias will be about 0.3 volt for many common germanium transistors, and about 0.6 volt for silicon transistors.

Handling Transistors Used in the proper circuit under correct operating potentials the life of a transistor is practically unlimited. Unnecessary transistor failure often occurs because the user does not know how to handle the unit or understand the limitations imposed on the user by virtue of the minute size of the transistor chip. Microwave transistors, in particular, are subject to damage due to improper handling. The following simple rules will help the user avoid unnecessary transistor failures:

Know how to handle the transistor. Static discharges may damage microwave transistors or certain types of field-effect transistors because of small emitter areas in the former and the thin active layer between the channel and the gate in the latter. The transistor should always be picked up by the case and not by the leads. The FET, moreover, should be protected against static electricity by wrapping the leads with tin-foil when it is not in use, or otherwise interconnecting the leads when the unit is moved about or stored. Finally, no transistor should be inserted into or removed from a socket when power is applied to the socket pins. *Never use an ohmmeter for continuity checks.* An ohmmeter may be used at some

risk to determine if certain types of transistors are open or shorted. On the low ranges, however, an ohmmeter can supply over 250 milliamperes into a low-resistance load. Many small transistors are rated at a maximum emitter current of 20 to 50 milliamperes and should be tested only in a transistor test set wherein currents and voltages are adjustable and limited. *Don't solder transistor leads unless you can do it fast.* Always use a low-wattage (20 watts or so) pencil iron and a heat sink when soldering transistors into or removing them from the circuit. Long-nose pliers grasping the lead between iron and transistor body will help to prevent transistor chip temperature from becoming excessive. Make the joint fast so that time does not permit the chip to overheat.

In-circuit precautions should also be observed. Certain transistors may be damaged by applying operating potential of reversed polarity, applying an excessive surge of transient voltage, or subjecting the equipment to excessive heat. Dissipation of heat from intermediate-size and power transistors is vital and such units should never be run without an adequate heat-sink apparatus. Finally, a danger exists when operating a transistor close to a high-powered transmitter. The input circuit of the transistorized equipment may be protected by shunting it with two small diodes back to back to limit input voltage excursions.

Transistor Symbols The electrical symbols for common three-terminal transistors are shown in figure 17. The left drawing is of a PNP transistor. The symbol for an NPN transistor is similar except that the direction of the arrow of the emitter points away from the base. This suggests that *the arrow points toward the negative terminal of the power source*, and the source potentials are reversed when going from NPN to PNP transistors, or vice-versa. As stated earlier, a useful rule-of-thumb common to both NPN and PNP transistors concerns the base-emitter bias: Moving the base toward the collector voltage turns the transistor *on*, and moving the base away from the collector voltage turns the transistor *off*. As shown in the illustration, capital letters are used for d-c voltages. The important d-c voltages existing in transistor circuitry

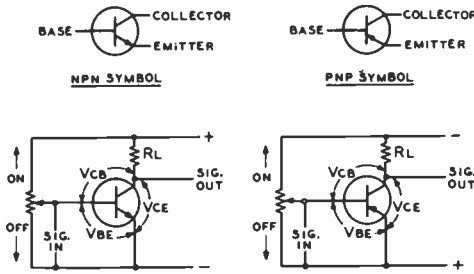

Figure 17

TRANSISTOR SYMBOLS AND BIAS

Moving the base potential toward the collector turns the transistor on. Moving the base potential away from the collector turns the transistor off. Voltage notations are: Collector-to-base voltage, V_{CB} ; base-to-emitter voltage, V_{BE} ; collector-to-emitter voltage, V_{CE} .

are: base-emitter voltage (V_{BE}), collector-emitter voltage (V_{CE}), and collector-base voltage (V_{CB}). Signal and alternating voltages and currents are expressed by lower-case letters.

5-5 Transistor Characteristics

The transistor produces results that may be comparable to a vacuum tube, but there is a basic difference between the two devices. The vacuum tube is a voltage-controlled device whereas the transistor is a current-controlled device. A vacuum tube normally operates with its grid biased in the negative, or high-resistance, direction, and its plate biased in the positive, or low-resistance, direction. The tube conducts only by means of electrons, and has its conducting counterpart in the form of the NPN transistor, whose majority carriers are also electrons. There is no vacuum-tube equivalent of the PNP transistor, whose majority carriers are holes.

As discussed earlier, the transistor may be turned off and on by varying the bias on the base electrode in relation to the emitter potential. Adjusting the bias to some point approximately midway between cutoff and saturation will place the transistor in the active region of operation. When operated in this region the transistor is capable of

amplification. The characteristics of a transistor biased in the active region may be expressed in terms of electrode voltages and currents as was done for vacuum tubes in Chapter Four. The plot of V_{CE} versus I_C (collector-emitter voltage versus collector current) shown in figure 18, for example, should be compared with figure 17, Chapter Four, the plot of I_b versus E_b (plate current versus plate voltage) for a pentode tube. Typical transistor graphs are discussed in this chapter, and the use of similar vacuum-tube plots is discussed in Chapter Six.

Transistor Analysis Transistor behavior may be analyzed in terms of mathematical equations which express the relationships among currents, voltages, resistances, and reactances. These relationships are termed *hybrid parameters* and define instantaneous voltage and current values existing in the circuit under examination. The parameters permit the prediction of the behavior of the particular circuit without actually constructing the circuit.

Equivalent circuits constructed from parameter data allow formulas to be derived

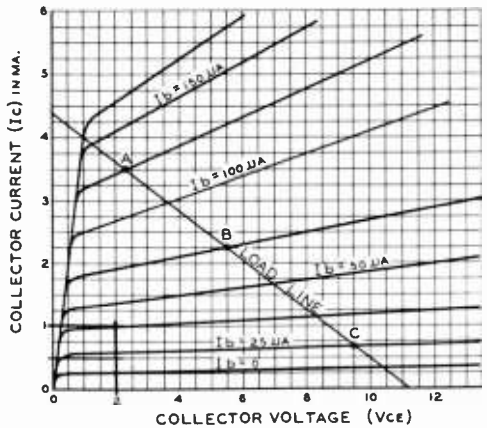

Figure 18

CHARACTERISTIC PLOT OF JUNCTION TRANSISTOR

Characteristics of junction transistor biased in active region may be expressed in terms of plot of collector voltage versus collector current. Load line and limits of operation (points A, C) are plotted, as well as operating point (B) in the manner shown in Chapter Six for vacuum-tube plots.

for current gain, voltage gain, power gain, and other important information necessary to establish proper transistor operation. A complete discussion of hybrid parameters and transistor circuitry may be obtained in the book *Basic Theory and Application of Transistors*, technical manual TM-11-690, available from the Superintendent of Documents, U.S. Government Printing Office, Washington, D.C. 20402.

Some of the more useful parameters for transistor application are listed below:

The *resistance gain* of a transistor is expressed as the ratio of output resistance to input resistance. The input resistance of a typical transistor is low, in the neighborhood of 500 ohms, while the output resistance is relatively high, usually over 20,000 ohms. For a junction transistor, the resistance gain is usually over 50.

The *voltage gain* of a transistor is the product of *alpha* times the *resistance gain*. A junction transistor which has a value of *alpha* less than unity nevertheless has a resistance gain of the order of 2000 because of its extremely high output resistance, and the resulting voltage gain is about 1800 or so. For this type of transistor the *power gain* is the product of *alpha squared* times the *resistance gain* and is of the order of 400 to 500.

The output characteristics of the junction transistor are of great interest. A typical example is shown in figure 19. It is seen that the junction transistor has the characteristics of an ideal pentode vacuum tube. The collector current is practically independent of the collector voltage. The range of linear operation extends from a minimum voltage of about 0.2 volts up to the maximum rated collector voltage. A typical load line is shown, which illustrates the very high load impedance that would be required for maximum power transfer. A common-emitter circuit is usually used, since the output impedance is not as high as when a common-base circuit is used.

Equivalent Circuit of a Transistor As is known from network theory, the small-signal performance of any device in any network can be represented by means of an equivalent circuit. The most convenient equivalent circuit for the low-

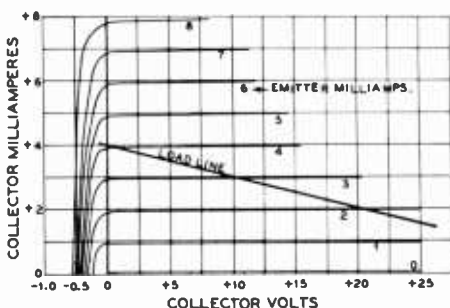
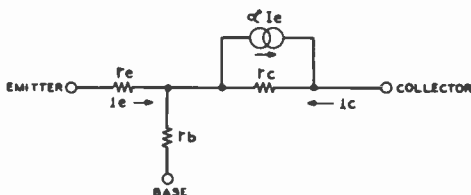

Figure 19
PLOT OF JUNCTION TRANSISTOR RESEMBLES PENTODE TUBE

Collector current is practically independent of collector voltage. Nearly horizontal load line indicates the high output impedance necessary for maximum power transfer.

frequency small-signal performance of junction transistors is shown in figure 20. r_e , r_{ib} , and r_c are dynamic resistances which can be associated with the emitter, base, and collector regions of the transistor. The current generator αi_e represents the transport of charge from emitter to collector.

Transistor Configurations There are three basic transistor configurations; grounded-base connection, grounded-emitter connection, and grounded-collector connection. These correspond roughly to grounded-grid, grounded-cathode, and



VALUES OF THE EQUIVALENT CIRCUIT

PARAMETER	JUNCTION TRANSISTOR ($i_e = 1 \text{ mA}$, $V_{CE} = 3 \text{ v}$)
r_e - EMITTER RESISTANCE	$\frac{25}{I_E}$
r_b - BASE RESISTANCE	300 Ω
r_c - COLLECTOR RESISTANCE	1 MEGOHM
α - CURRENT AMPLIFICATION	0.97

Figure 20
LOW-FREQUENCY EQUIVALENT CIRCUIT (COMMON-BASE) FOR JUNCTION TRANSISTOR

grounded-plate circuits in vacuum-tube terminology (figure 21).

The grounded-base circuit has a low input impedance and high output impedance, and no phase reversal of signal occurs from input to output circuit. The grounded-emitter circuit has a higher input impedance and a lower output impedance than the grounded-base circuit, and a reversal of phase between the input and output signal occurs. This usually provides maximum voltage gain from a transistor. The grounded-collector circuit has relatively high input impedance, low output impedance, and no phase reversal of signal from input to output circuit. Power and voltage gain are both low.

Bias Stabilization To establish the correct operating parameters of the transistor, a bias voltage must be established between the emitter and the base. Since transistors are temperature-sensitive devices, and since some variation in characteristics usually exists between transistors of a given type, attention must be given to the bias system to overcome these difficulties. The simple *self-bias* system is shown in figure 22A. The base is simply connected to the power supply through a large resistance which supplies a fixed value of base current to the transistor. This bias system is extremely sensitive to the current-transfer ratio of the transistor, and must be adjusted for optimum results with each transistor.

When the supply voltage is fairly high and wide variations in ambient temperature do not occur, the bias system of figure 22B

may be used, with the bias resistor connected from base to collector. When the collector voltage is high, the base current is increased, moving the operating point of the transistor down the load line. If the collector voltage is low, the operating point moves upward along the load line, thus providing automatic control of the base bias voltage. This circuit is sensitive to changes in ambient temperature, and may permit transistor failure when the transistor is operated near maximum dissipation ratings.

These circuits are often used in small imported transistor radios and are not recommended for general use unless the bias resistor is selected for the value of current gain of the particular transistor in use. A better bias system is shown in figure 22C, where the base bias is obtained from a voltage divider, (R_1 , R_2), and the emitter is forward-biased. To prevent signal degeneration, the emitter bias resistor is bypassed with a large capacitance. A high degree of circuit stability is provided by this form of bias, providing the emitter capacitance is of the order of 50 μ fd for audio-frequency applications.

Output Characteristic Curves Calculation of the current, voltage and power gain of a common-emitter amplifier may be accomplished by using the common-emitter output static characteristic curves (figure 23) which plot collector current against collector voltage with the base current as a fixed value. In this example, the collector voltage supply is 10 volts, the load resistance is 1500 ohms,

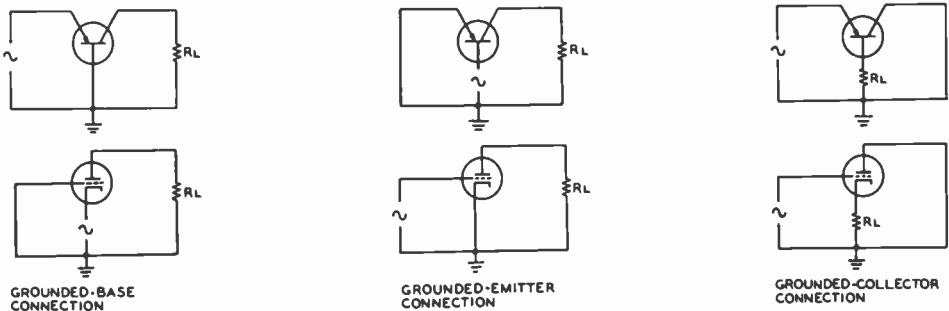

Figure 21

COMPARISON OF BASIC VACUUM-TUBE AND TRANSISTOR CONFIGURATIONS

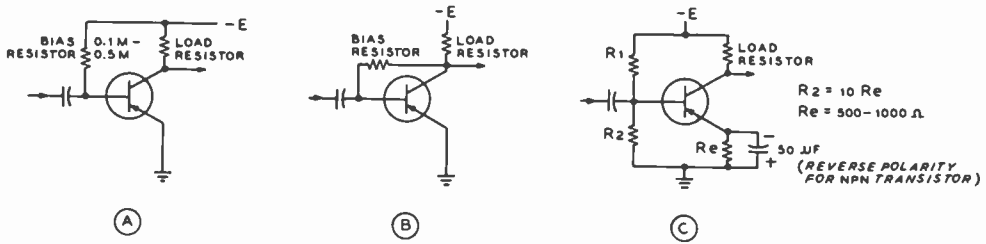

Figure 22

BIAS CONFIGURATIONS FOR TRANSISTORS

The voltage divider system of C is recommended for general transistor use. Ratio of R_1/R_2 establishes base bias, and emitter bias is provided by voltage drop across R_e . Battery polarity is reversed for NPN transistors.

the emitter resistance is 500 ohms, the peak-to-peak input current is 20 microamperes and the operating point (X) is chosen at 25 microamperes of base current and 4.8 volts on the collector.

The first step is to establish a load line on the characteristic curves representing the voltage drop across the load resistor (R_2). When the collector current is zero, the total collector supply voltage (10 volts) equals the collector voltage, V_{CE} . Point Z (one point of the load line) then is at the 10-volt mark on the collector voltage axis (x-axis). When the collector current is zero, the total collector supply voltage (10 volts) is dropped across load resistor R_2 . The total current (I_c) then is:

$$I_c = \frac{10}{1500} = 0.0066 \text{ amp} = 6.6 \text{ ma}$$

Point Y (a second point of the load line) then is at the 6.6-ma mark on the collector-current axis (y-axis). Connect points Y and Z to establish the load line. The operating point is located at point X on the load-line. Since the peak-to-peak input current is 20 microamperes, the deviation is 10 microamperes above the operating point (point M) and 10 microamperes below the operating point (point N).

The input current, output current, and output voltage waveforms may now be established by extending lines from the operating point perpendicular to the load line and to the y and x axes respectively and

plotting the waveforms from each deviation point along the load-line excursions between points M and N.

Current gain (beta) in this configuration is the ratio of the change in collector current to the change in base current:

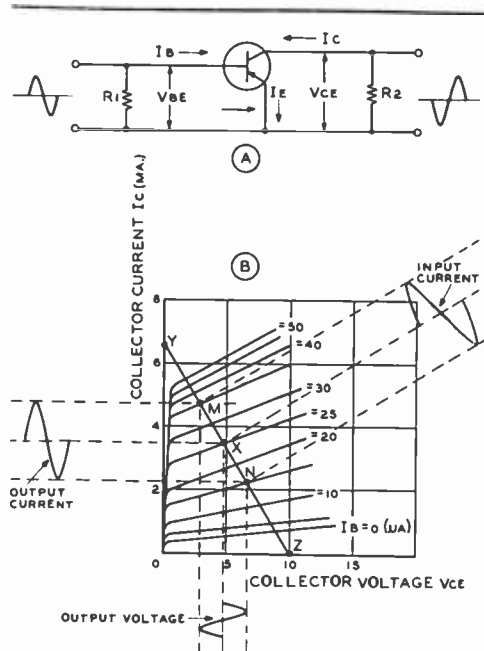

Figure 23

CHARACTERISTIC CURVES AND LOAD LINE FOR COMMON-EMITTER CIRCUIT

Calculation of current, voltage and power gain of a common-emitter transistor amplifier can be accomplished by using output characteristic curves as discussed in the text.

$$A_i = \frac{\Delta I_C}{\Delta I_B} = \frac{I_{C(max)} - I_{C(min)}}{I_{B(max)} - I_{B(min)}}$$

where,

- A_i is current gain,
- I_C is collector current,
- I_B is base current,
- Δ equals a small increment.

Substituting known values in the formula:

$$\begin{aligned} \text{Current Gain } (A_i) &= \\ \frac{4.7 - 2.1}{35 - 15} &= \frac{2.6 \text{ ma}}{20 \mu a} = 130 \end{aligned}$$

Voltage gain in this configuration is the ratio of the change in collector voltage to the change in base voltage:

$$A_v = \frac{\Delta V_{CE}}{\Delta V_{BE}} = \frac{V_{CE(max)} - V_{CE(min)}}{V_{BE(max)} - V_{BE(min)}}$$

where,

- A_v is voltage gain,
- V_{CE} is collector to emitter voltage,
- V_{BE} is base to emitter voltage.

(Note: The change in input voltage is the change in input current multiplied by the input impedance. In this case the input voltage is: 20 microamperes times 500 ohms, or 0.01 volt).

Therefore:

$$\text{Voltage Gain } (A_v) = \frac{6.7 - 2.7}{0.01} = 400$$

Power gain is voltage gain times current gain:

$$\text{Power gain} = 130 \times 400 = 52,000$$

Power gain in decibels is:

$$\begin{aligned} \text{Gain} &= 10 \log 52,000 = 10 \times 4.7 \\ &= 47 \text{ decibels} \end{aligned}$$

Constant-Power-Dissipation Line Each transistor has a maximum collector power that it can safely dissipate without damage to the transistor. To ensure that the maximum collector dissipation rating is not exceeded, a *constant-power-dissipation line* (figure 24) is drawn on the characteristic curves, and the collector load

resistor is selected so that its load line falls in the area bounded by the vertical and horizontal axes and the constant-power-dissipation line. The dissipation line is determined by selecting points of collector voltage and current, the products of which are equal to the maximum collector power rating of the transistor. Any load line selected so that it is tangent to the constant-power-dissipation line will ensure maximum permissible power gain of the transistor while operating within the maximum collector power-dissipation rating. This is important in the design and use of power amplifiers.

5-6 Transistor Circuitry

The transistor can be connected as either a common-base, common-collector, or common-emitter stage, as discussed previously. Similar to the case for vacuum tubes, choice of transistor circuit configuration depends on the desired operating characteristics of the stage. The over-all characteristics of

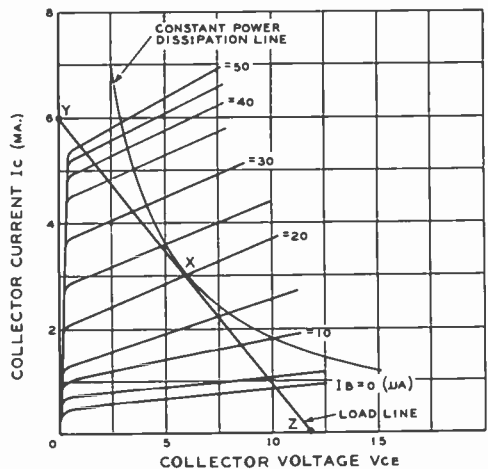

Figure 24

CONSTANT POWER-DISSIPATION LINE

Constant power-dissipation line is placed on output characteristic curves, with collector load line positioned so it falls within area bounded by vertical and horizontal axes and constant power-dissipation line. Load line tangent at (X) permits maximum power gain within maximum collector dissipation rating.

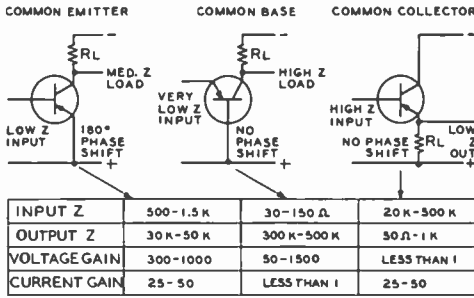

Figure 25

THREE BASIC TRANSISTOR CIRCUITS

Common-emitter circuits are used for high-gain amplification, common-base circuits are useful for oscillator circuits and common-collector circuits are used for various impedance transformations.

these three circuits are summarized in figure 25. Common-emitter circuits are widely used for high-gain amplification, and common-base circuits are useful for oscillator circuits and high-frequency operation, and common-collector circuits are used for various impedance transformation applications. Examples of these circuits will be given in this section.

Audio Circuitry As in the case of electron-tube amplifiers, transistor amplifiers can be operated class A, class AB, class B, or class C. The first three classes are used in audio circuitry. The class-A transistor amplifier is biased so that collector current flows continuously during the complete electrical cycle, even when no drive

signal is present. The class-B transistor amplifier can be biased either for collector current cutoff or for zero collector voltage. The former configuration is most often used, since collector current flows only during that half-cycle of the input signal voltage that aids the forward bias. This bias technique is used because it results in the best power efficiency. Class-B transistor amplifiers must be operated in push-pull to avoid severe signal distortion. Class-AB transistor amplifiers can be biased so that either collector current or voltage is zero for less than half a cycle of the input signal, and the above statements for class-B service also apply for the class-AB mode.

A simple small-signal voltage amplifier is shown in figure 26A. Direct-current stabilization is employed in the emitter circuit. Operating parameters for the amplifier are given in the drawing. In this case, the input impedance of the amplifier is quite low. When used with a high-impedance driving source such as a crystal microphone a step-down input transformer should be employed as shown in figure 26B.

The circuit of a two-stage resistance-coupled amplifier is shown in figure 27A. The input impedance is approximately 1100 ohms. Feedback may be placed around this amplifier from the emitter of the second stage to the base of the first stage, as shown in figure 27B. A direct-coupled version of the resistance-coupled amplifier is shown in figure 27C. The input impedance is of the order of 15,000 ohms, and an over-all voltage gain of 80 may be obtained with a supply potential of 12 volts.

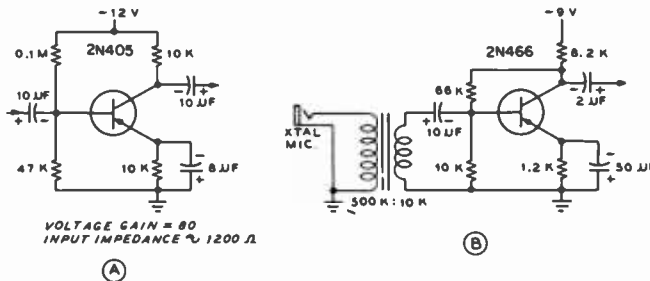

Figure 26

TRANSISTOR VOLTAGE AMPLIFIERS

A—Resistance coupled class-A audio amplifier. For use with high-impedance microphone, a step-down input transformer is required, as shown in B. For PNP transistors, battery and capacitor polarities are reversed.

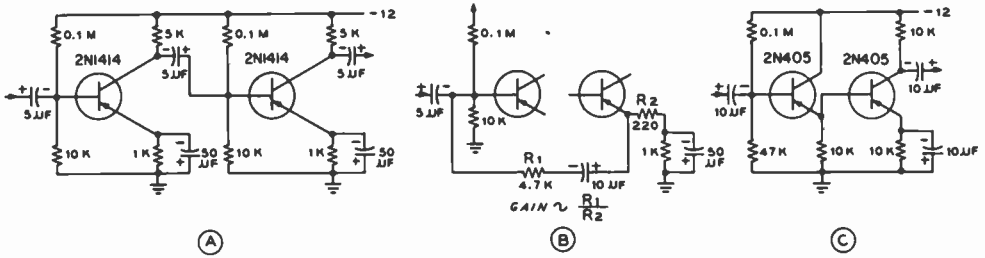

Figure 27

TWO-STAGE TRANSISTOR AUDIO AMPLIFIER

The feedback loop of B may be added to the RC amplifier to reduce distortion, or to control the audio response. A direct-coupled amplifier is shown in C.

It is possible to employ NPN and PNP transistors in *complementary-symmetry* circuits which have no equivalent in vacuum-tube design. Figure 28A illustrates such a circuit. A symmetrical push-pull circuit is shown in figure 28B. This circuit may be used to directly drive a high-impedance speaker, eliminating the output transformer. A direct-coupled three-stage amplifier having a gain figure of 80 db is shown in figure 28C. The latter circuit should be used with caution since it results in a serious d-c drift with temperature change.

smaller units provide power levels of a few milliwatts. The correct operating point is chosen so that the output signal can swing equally in the positive and negative directions, as shown in the collector curves of figure 29B.

The proper primary impedance of the output transformer depends on the amount of power to be delivered to the load:

$$R_p = \frac{E_c^2}{2P_o}$$

The transistor may also be used as a class-A power amplifier as shown in figure 29.

The collector current bias is:

$$I_c = \frac{2P_o}{E_c}$$

Commercial transistors are available that will provide five or six watts of audio power when operating from a 12-volt supply. The

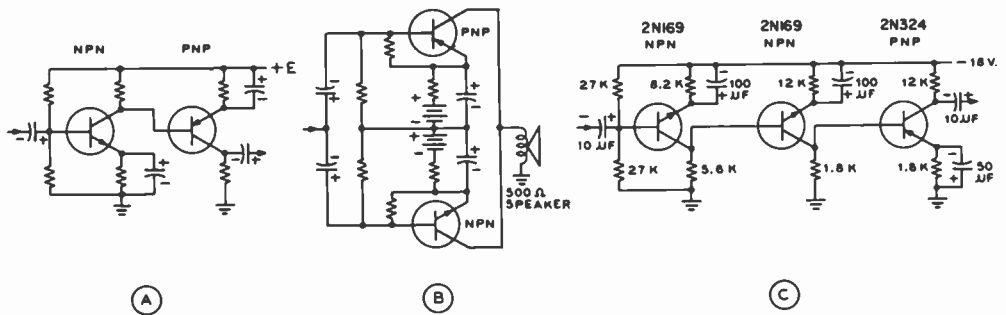

Figure 28

COMPLEMENTARY-SYMMETRY AMPLIFIERS

NPN and PNP transistors may be combined in circuits which have no equivalent in vacuum-tube design. Direct coupling between cascaded stages using a single power-supply source may be employed, as in C. Impedance of power supply should be extremely low.

Figure 29

TYPICAL CLASS-A AUDIO POWER TRANSISTOR CIRCUIT

The correct operating point is chosen so that output signal can swing equally in a positive or negative direction, without exceeding maximum collector dissipation.

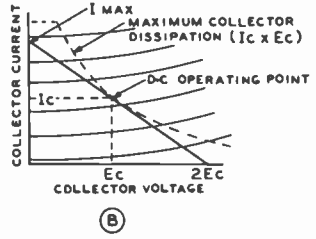
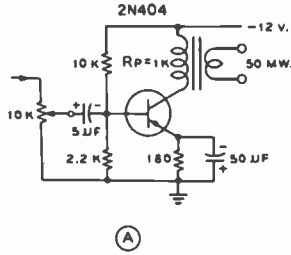

In a class-A output stage, the maximum a-c power output obtainable is limited to 0.5 the allowable dissipation of the transistor. The product $I_c E_c$ determines the maximum collector dissipation, and a plot of these values is shown in figure 29B. The load line should always lie under the dissipation curve, and should encompass the maximum possible area between the axes of the graph for maximum output condition. In general, the load line is tangent to the dissipation curve and passes through the supply-voltage point at zero collector current. The d-c operating point is thus approximately one-half the supply voltage.

The circuit of a typical push-pull class-B transistor amplifier is shown in figure 30A. Push-pull operation is desirable for transistor operation, since the even-order harmonics are largely eliminated. This permits transistors to be driven into high collector-current regions without distortion normally caused by nonlinearity of the collector. Crossover distortion is reduced to a minimum by providing a slight forward base bias in addition to the normal emitter bias. The base bias is usually less than 0.5 volt in most cases. Excessive base bias will boost the quiescent collector current and thereby lower the over-all efficiency of the stage.

The operating point of the class-B amplifier is set on the $I_c = 0$ axis at the point

where the collector voltage equals the supply voltage. The collector-to-collector impedance of the output transformer is:

$$R_{c-c} = \frac{2E_c^2}{P_o}$$

In the class-B circuit, the maximum a-c power input is approximately equal to three times the allowable collector dissipation of each transistor. Power transistors, such as the 2N514 have collector dissipation ratings of 80 watts and operate with class-B efficiency of about 67 percent. To achieve this level of operation the heavy-duty transistor relies on efficient heat transfer from the transistor case to the chassis, using the large thermal capacity of the chassis as a *heat sink*. An infinite heat sink may be approximated by mounting the transistor in the center of a 6" X 6" copper or aluminum sheet. This area may be part of a larger chassis.

The collector of most power transistors is electrically connected to the case. For applications where the collector is not grounded a thin sheet of mica may be used between the case of the transistor and the chassis.

Large, inexpensive power transistors such as the 2N441 may be used as modulators for medium power a-m mobile equipment. Such a modulator is shown in figure 31. It is capable of a power output of about 35

Figure 30 CLASS-B AUDIO AMPLIFIER CIRCUITRY

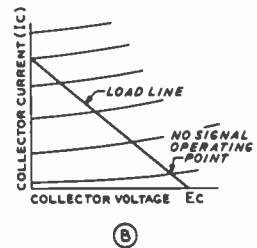
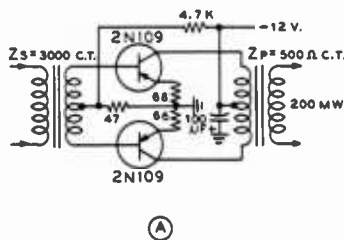

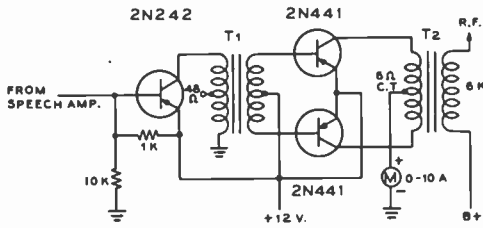

Figure 31

35-WATT MODULATOR

T_1 —48-ohm CT to 3/8/16 sec. use 3-ohm tap as CT (Thordarson TR-61). T_2 —6-ohm CT to 6k (Triad TY-66A). Transistors mounted on heat sink with mica washers.

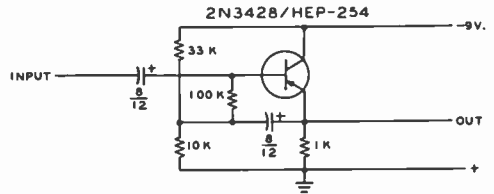

Figure 32

HIGH INPUT IMPEDANCE (BOOTSTRAP) AMPLIFIER

High input impedance provided by simple feedback circuit makes this amplifier attractive for use with crystal microphones and other high-impedance devices. Input impedance may run from 100K to 10 megohms.

watts and is capable of plate-modulating a 70-watt transmitter.

The "Bootstrap" Circuit

The bipolar transistor in common-emitter configuration presents a low input impedance unsuitable for use with high-impedance driving sources such as a crystal microphone or a diode voltmeter probe. The bootstrap circuit of figure 32 provides a very high input impedance for these special circuits. The low-impedance base-bias network is isolated from the input circuit by the 100K resistor. The signal is fed to the base of the transistor and the output signal, taken across the emitter resistor, is also coupled to the bottom of the 100K isolating resistor via a capacitor. When a signal appears at the base, it also appears at the emitter in the same phase and almost the same amplitude. Thus, nearly identical signal voltages appear at the ends of the isolating resistor and little or no signal current flows through it. The resistor then resembles an infinitely high impedance to the signal current, thus effectively isolating the base-bias resistors. Since the isolating resistor has no effect on the bias level, the base bias remains unchanged. In practice, the signal voltage at the emitter is slightly less than at the base, thus limiting the over-all effectiveness of the circuit. For example, if the emitter-follower voltage gain is 0.99, and the value of the isolating resistor is 100K, the effective resistance to the a-c input signal is 100K raised to 10 megohms, an increase in value by a factor of 100 times.

R-F Circuitry Transistors having a high value of *beta* and low internal capacitance may be used in r-f circuits. External feedback circuits are often used to counteract the effects of internal transistor feedback and to provide more stable performance at high gain figures. Modern silicon planar junction transistors are capable of operation into the vhf region without external neutralization when used in properly isolated circuits. Shown in figures 33 are two such r-f amplifiers. Illustration A is of a common-emitter amplifier commonly used as an r-f amplifier up to 200 MHz or so. A coupling winding is used in the base circuit to match the relatively low input impedance of the transistor to the high-impedance tuned input circuit. The common-base circuit performs well at 432 MHz with suitable transistors in a configuration such as the one shown in figure 33B. Shown in figure 34 is a common-base 432-MHz amplifier using a 2N3478 epitaxial planar transistor which combines a low noise figure, low internal capacitance, and a high gain-bandwidth product. The amplifier requires no neutralization and has a stage gain of over 15 db with a noise figure of better than 5 db at 432 MHz.

Transistor i-f amplifiers resemble the r-f circuitry previously discussed. Shown in figure 35A is a typical i-f amplifier employing an NPN transistor. The collector current is determined by a voltage divider in the base circuit and by a bias resistor in the emitter leg. Input and output are coupled by means of tuned i-f transformers. Bypass capacitors are placed across the bias resistors

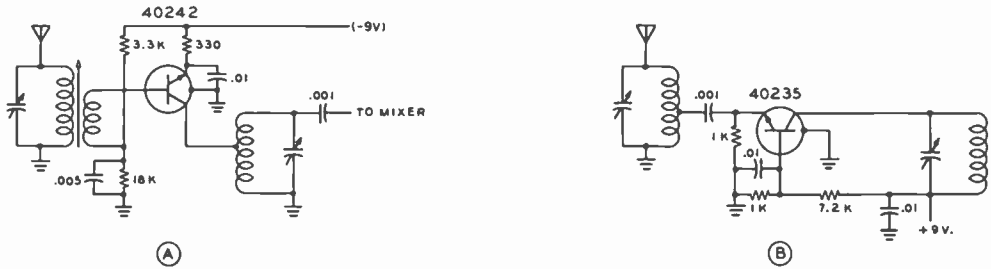

Figure 33

TRANSISTOR R-F AMPLIFIERS

A—Common-emitter amplifier used up to 200 MHz or so. B—Common-base amplifier often used at 432 MHz.

to prevent signal-frequency degeneration. The base is connected to a low-impedance untuned winding of the input transformer, and the collector is connected to a tap on the output transformer to provide proper matching, and also to make the performance of the stage relatively independent of variations between transistors of the same type. With a rate-grown NPN transistor such as the 2N293, it is unnecessary to use neutralization to obtain circuit stability. When PNP alloy transistors are used, it is necessary

to neutralize the circuit to obtain stability (figure 35B).

The gain of a transistor i-f amplifier will decrease as the emitter current is decreased. This transistor property can be used to control the gain of an i-f amplifier so that weak and strong signals will produce the same audio output. A special i-f strip incorporating this automatic volume-control action is shown in figure 36.

R-f transistors may be used as mixers or autodyne converters much in the same man-

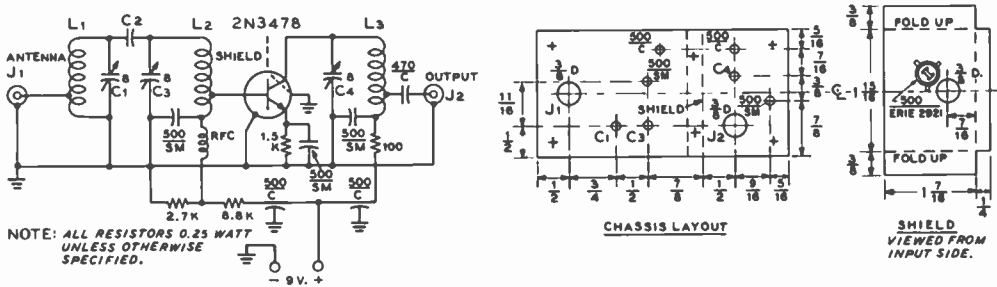

NOTE: ALL RESISTORS 0.25 WATT UNLESS OTHERWISE SPECIFIED.

- NOTE: 1. ALL INDUCTORS VIEWED ON EDGE.
 2. ALL INDUCTORS MADE OF 1/4 INCH WIDE STRIPS OF 1/64 INCH THICKNESS FLASHING COPPER.
 3. ADJACENT EDGES OF L2 & L3 ARE 15/16 INCH APART.
 4. SHIELD MADE OF 1/64 INCH THICKNESS FLASHING COPPER.
 5. 500 SM ARE BUTTON CAPACITORS (ERIE 2922).

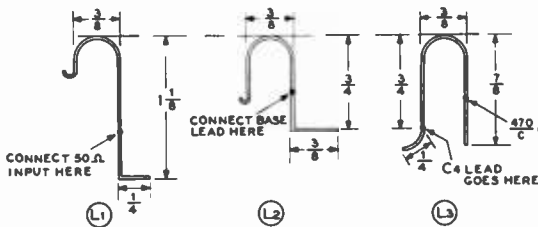

Figure 34

SCHMATIC AND LAYOUT FOR 432-MHz R-F AMPLIFIER

- C₂, C₃, C₄—0.5- to 8-pt piston trimmer capacitor. JFD PC35-H080 or equiv.
 C₁—3-pt ceramic capacitor. (see text)
 RFC—7 turns #22 e., 1/8-inch long (Ohmite Z-460)
 J₁, J₂—BNC connector, chassis mounting. UG-657/U or equiv.
 Box—4" x 2 1/8" x 1 3/8" (Bud 3002A)

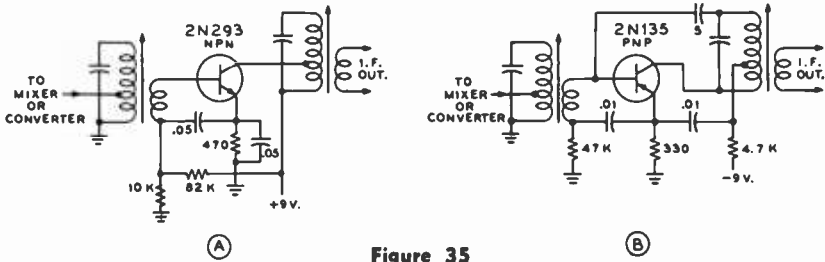

Figure 35

TRANSISTOR I-F AMPLIFIERS

Typical PNP transistor must be neutralized because of high collector capacitance. Rate-grown NPN transistor does not usually require external neutralizing circuit.

ner as vacuum tubes. The autodyne circuit is shown in figure 37. Transformer T_1 feeds back a signal from the collector to the emitter causing oscillation. Capacitor C_1 tunes the oscillator circuit to a frequency 455 kHz higher than that of the incoming signal. The local-oscillator signal is inductively coupled into the emitter circuit of the transistor. The incoming signal is resonated in T_2 and coupled via a low-impedance winding to the base circuit. Notice that the base is biased by a voltage-divider circuit much the same as is used in audio-frequency operation. The two signals are mixed

in this stage and the desired beat frequency of 455 kHz is selected by i-f transformer T_3 and passed to the next stage. Collector currents of 0.6 ma to 0.8 ma are common, and the local-oscillator injection voltage at the emitter is in the range of 0.15 to 0.25 volts, rms.

A receiver "front end" capable of operation through the 10-meter band is shown in figure 38. The inexpensive RCA type 2N1177 or 2N1180 transistors are used. If proper shielding is employed between the tuned circuits of the r-f stage and the mixer, no neutralization of the r-f stage is

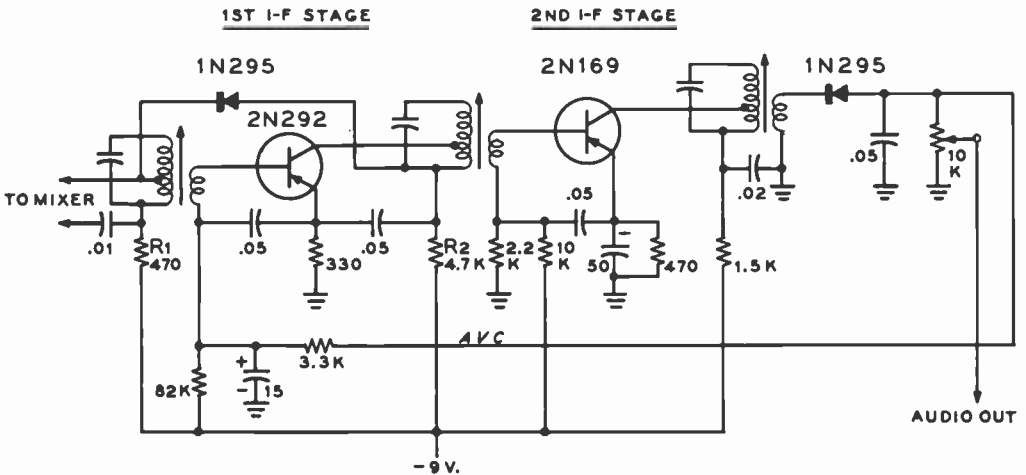

Figure 36

AUTOMATIC-VOLUME-CONTROL CIRCUIT

An auxiliary diode AVC circuit is used to shunt a portion of the signal to ground at high signal levels. Diode is back-biased by resistors R_1 and R_2 .

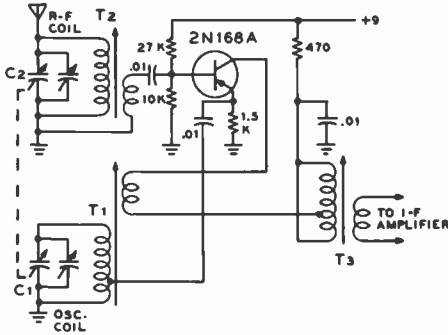

Figure 37

THE AUTODYNE CONVERTER CIRCUIT USING A 2N168A AS A MIXER

required. The complete assembly obtains power from a 3-volt battery. The base of the r-f transistor is link-coupled to the r-f coil to achieve proper impedance match.

The oscillator operates on its third harmonic to produce an intermediate frequency of 1.6 MHz.

Other r-f and i-f transistor circuitry is discussed in Chapter 10, *Radio Receiver Fundamentals*.

Transistor Oscillators Sufficient coupling between input and output circuits of the transistor amplifier via collector-base capacitance or via external circuitry will permit oscillation up to and slightly above the alpha-cutoff frequency. Various forms of transistor oscillators are shown in figure 39. A simple grounded-emitter Hartley oscillator having positive feedback between the base and the collector (39A) is compared to a grounded-base Hartley oscillator (39B). In each case the resonant tank circuit is common to the input and output circuits of the transistor. Self-bias of the transistor is employed in both these circuits.

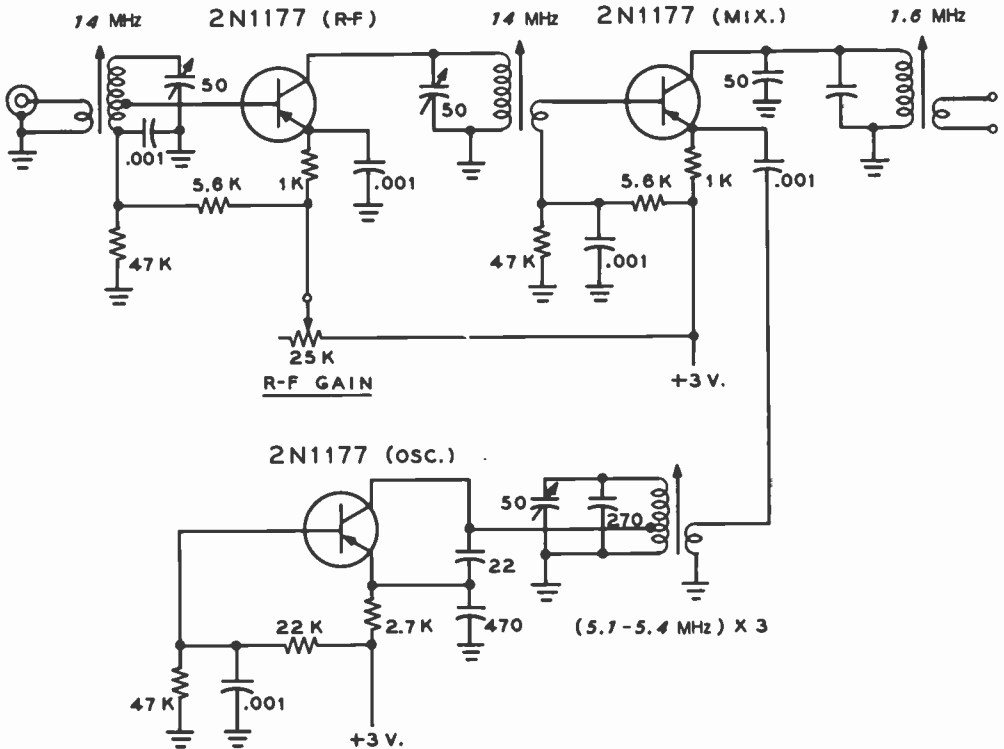

Figure 38

RECEIVER "FRONT END" FOR USE UP TO 30 MHz

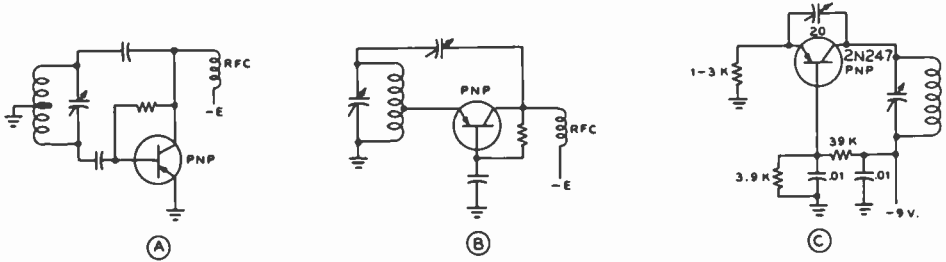

Figure 39

TYPICAL TRANSISTOR OSCILLATOR CIRCUITS

A-Grounded-emitter Hartley. B-Grounded-base Hartley. C-2N247 oscillator suitable for 50-MHz operation.

A typical transistor crystal oscillator and frequency-multiplier circuit are shown in figure 40. The 2N707 NPN transistor operates at 25 MHz, driving a 2N2218 doubler to 50 MHz and a 2N2786 amplifier. Diode CR₁ is for bias stabilization.

Shown in figures 41A and B are transistor versions of a crystal-oscillator circuit and an RC audio oscillator, both of which are comparable to their vacuum-tube counterparts. Additional oscillator circuits are found in later chapters of this handbook.

Transistors are also widely used in counting circuits, multivibrators, and blocking oscillators in a variety of instruments. Typical industrial circuits are shown in figures 41C and D. Illustration 41C shows a transformer-coupled blocking oscillator. The oscillator may be synchronized by coupling the locking signal to the base circuit of the

transistor. An oscillator of this type may be used to drive a flip-flop circuit as a counter. An Eccles-Jordan bistable flip-flop circuit employing surface-barrier transistors may be driven between "off" and "on" positions by an exciting pulse as shown in figure 41D. The first pulse drives the "on" transistor into saturation. This transistor remains in a highly conductive state until the second exciting pulse arrives. The transistor does not immediately return to the cutoff state, since a time lapse occurs before the output waveform starts to decrease. This *storage time* is caused by the transit lag of the minority carriers in the base of the transistor. Proper circuit design can reduce the effects of storage time to a minimum. Driving pulses may be coupled to the multivibrator through *steering diodes* as shown in the illustration.

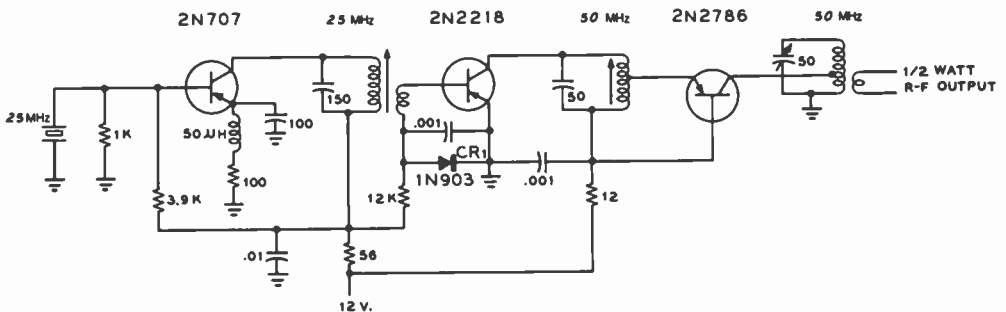

Figure 40

50-MHz TRANSISTORIZED EXCITER

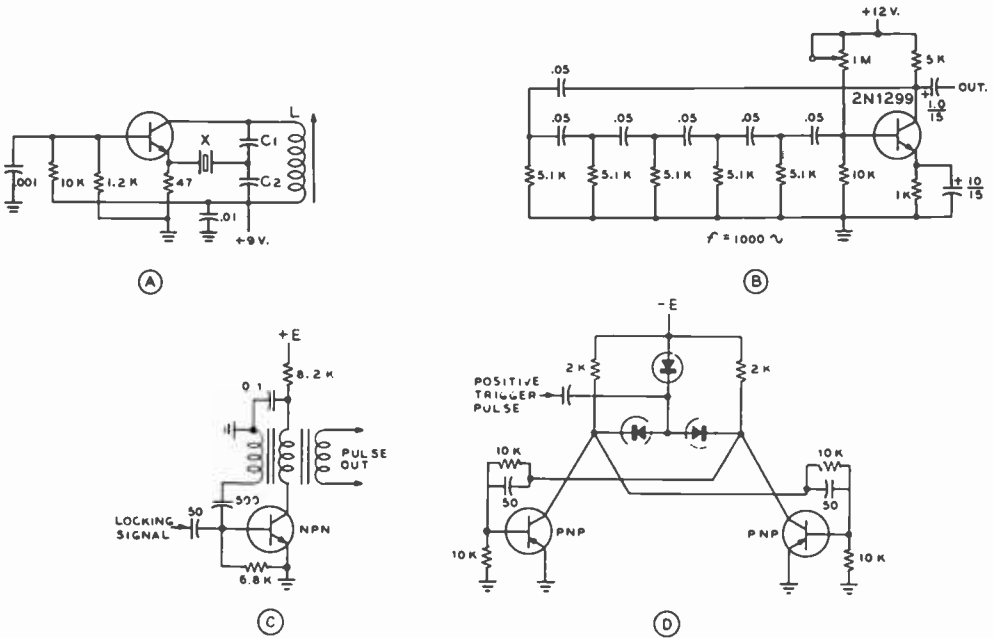

Figure 41

TRANSISTOR OSCILLATORS

A—NPN high-frequency transistor used in crystal oscillator. Ratio of C₁ to C₂ determines feedback. B—RC audio oscillator. Constants are shown for 1000 Hz. C—Transformer coupled blocking oscillator. D—Eccles-Jordan bistable flip-flop circuit.

5-7 The Field-Effect Transistor

The *junction field-effect transistor (JFET)*, or unipolar transistor, was first explored in 1928 but it was not until 1958 that the first practical field-effect transistor was developed. The field-effect transistor is an N- or P-channel amplifying device which modulates the flow of current in a semiconductor channel by establishing regions of depletion (lack of current carriers: holes or electrons) between the electron *source* and the *drain*. Depletion control is exercised by a *gate* consisting of a junction of opposite intrinsic material sandwiching part of the conducting path (figure 42). Two basic types of field-effect transistors available today are the junction FET (JFET) and the *metal-oxide semiconductor FET (MOSFET)*. The latter is also referred to as the *insulated-gate FET (IGFET)*.

FET Types Field-effect transistors are divided into two groups: junction-gate and insulated-gate. The junction-gate type is shown in figure 42.

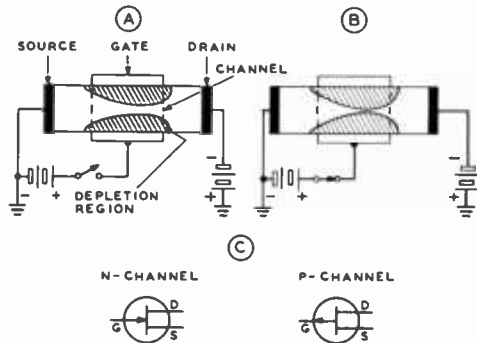

Figure 42

Depletion control is exercised by a "gate" of opposite intrinsic material across the conducting path.

When external reverse bias is applied, the region of depletion extends into the conducting path, thus restricting the carrier flow through the channel. At maximum gate bias, the depletion region is nearly complete and the channel is *pinched-off*, or reduced. In effect, the conductive cross-section of the channel is controlled by the bias signal. This action is analogous to that of the vacuum tube, where a potential on the grid affects the plate current, but the charge carrying the signal does not flow in the region between cathode and plate to any significant extent.

The insulated-gate field-effect transistor (IGFET) differs from the JFET in that there is no junction between gate and channel, the gate electrode being separated by an insulating layer of silicon dioxide. The gate-metal area is overlaid on the oxide and in conjunction with the insulating layer and the semiconductor channel forms a capacitor. In both the FET and the JFET the regions where current movement is restricted are termed the *depletion areas* and areas of electron movement are termed *enhancement areas*.

Depletion-mode FET's are normally turned on when no bias is applied between gate and source. In contrast to the JFET, however, the IGFET can be forward-biased in the enhancement mode, or reverse-biased in the depletion mode as the *back gate* element (or body) is brought out to a separate terminal or is connected to the source. Symbols for typical IGFET's are shown in figure 43.

The gate voltage of the JFET is limited in the reverse direction by the avalanche breakdown potential of the gate-to-source and gate-to-drain circuits. With the IGFET, on the other hand, gate voltage limitation is the point of destructive breakdown of the oxide dielectric under the gate. This breakdown must be avoided to prevent permanent damage to the oxide. Gate protection is often included within the device in the form of a zener diode on the chip between the gate and body.

FET Characteristics The field-effect transistor has been compared to a vacuum tube in that the input impedance is quite high, the output impedance

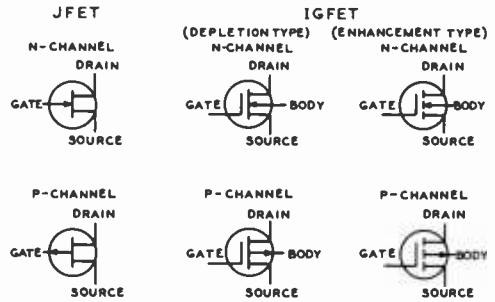

Figure 43

SYMBOLS AND NOMENCLATURE FOR FIELD-EFFECT TRANSISTORS

quite low, and the FET elements resemble those of the vacuum tube (gate = grid, drain = plate, source = cathode). In addition, the FET features high stage gain and low feedthrough capacitance. With these characteristics, the FET is often considered as the solid-state equivalent of the vacuum tube and can be used in virtually identical circuits, provided power ratings are observed.

One of the virtues of the IGFET is that it exhibits extremely low levels of cross modulation when used as an r-f amplifier and is superior to common bipolar transistors in this important respect.

The current-voltage characteristics of an IGFET are similar to those of a vacuum tube. For example, the 3N128 uses positive drain voltages and usually negative gate voltages, which are analogous to the plate and grid voltages, respectively, of electron

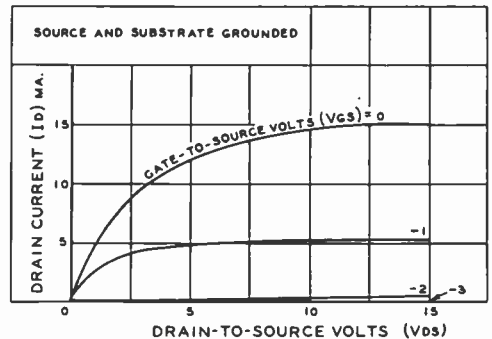

Figure 44

TRANSFER CHARACTERISTIC OF IGFET TYPE 3N128

tubes. The transfer characteristic of the 3N128 is shown in figure 44.

FET Circuitry Field-effect transistors are most often used in the common-source circuit configuration shown in figure 45. Common-gate or common-drain circuits may be used, but these provide very low gain, especially at the higher frequencies. The FET type, however, may be used at vhf in common-source or common-drain circuitry for maximum stability. A cascode vhf FET circuit is shown in figure 46.

5-8 Integrated Circuits

The *integrated circuit* (IC) comprises a family in the field of microelectronics in which small, conventional components are combined in an orderly fashion in compact, high-density assemblies (*micromodules*). Integrated circuits may be composed of passive elements (resistors, capacitors, and interconnections), and active elements such as diodes and transistors. The IC family may be divided into *monolithic* and multichip, or *hybrid*, circuits. The former category consists of an entire circuit function constructed in a single semiconductor block. The latter consists of two or more semiconductor blocks, each containing active or passive elements interconnected to form a complete circuit and assembled in a single package.

Integrated circuits offer relief in complex systems by permitting a reduction in the number of pieces and interconnections making up the system, a reduction in overall system size, better transistor matching and potentially lower system cost.

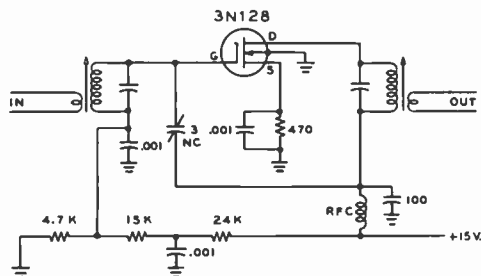

Figure 45

COMMON-SOURCE IGFET R-F AMPLIFIER

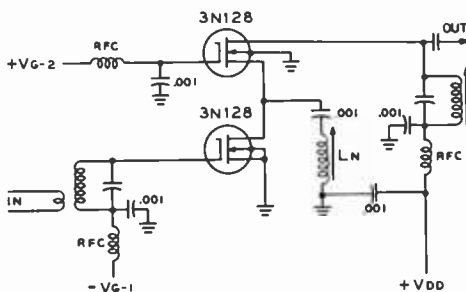

Figure 46

CASCODE IGFET AMPLIFIER

Using very small monolithic IC's makes it possible to make thousands of circuits simultaneously. For example, several hundred *dice* (plural of die) may be produced side by side from a single silicon slice in the simultaneous processing of about a hundred slices. Each die contains a complete circuit made up of ten to one hundred or more active and inactive components.

The silicon slice is prepared by an *epitaxial* process, which is defined as "the placement of materials on a surface." Epitaxy is used to grow thin layers of silicon on the slice, the layer resistivity controlled by the addition of N-type or P-type impurities (*diffusion*) to the silicon atoms being deposited. When localized regions are diffused into the base material (*substrate*), isolated circuits are achieved. Diffusion of additional P-type or N-type regions forms transistors.

Once the die is prepared by successive diffusions, a photomasking and etching process cuts accurately sized-and-located windows in the oxide surface, setting the circuit element dimensions simultaneously on every circuit in the slice. The wafer is then coated with an insulating oxide layer which can be opened in areas to permit metalization and interconnection.

The metalization process follows next, connecting circuit elements in the substrate. Electrical *isolation barriers* (insulators) may be provided in the form of reverse-biased P-N junctions, or the resistance of the substrate may be used. Dielectric insulation, making use of a formed layer around a sensitive region is also employed. Successive diffusion processes produce transistors and circuit elements of microscopic size, ready

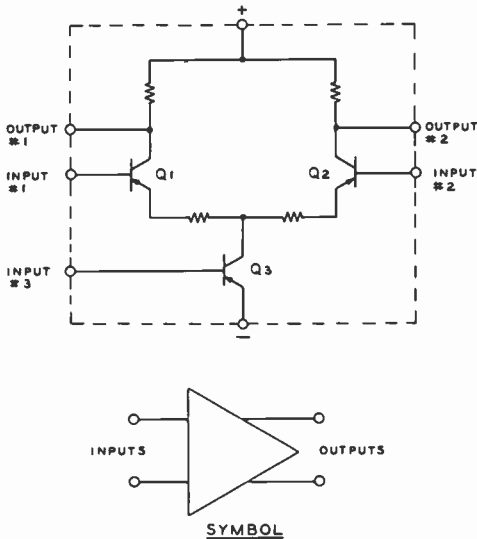

Figure 47

DIFFERENTIAL INTEGRATED-CIRCUIT AMPLIFIER

to have external leads bonded to them, and suitable for encapsulation.

Typical IC dice range in size from less than 0.02" square up to 0.08" X 0.2". Many package configurations are used, the most popular being the *multi-pin TO-5 package*, the *dual in-line package*, the *flat package*, and the inexpensive *epoxy package*.

Digital and Linear IC's Integrated circuits may be classified in terms of their functional end-use into two families:

Digital—A family of circuits that operate effectively as "on-off" switches. These circuits are most frequently used in computers to count in accord with the absence or presence of a signal.

Linear (Analog)—A family of circuits that operate on an electrical signal to change its shape, increase its amplitude, or modify it for a specific use.

The *differential amplifier* is a basic circuit configuration for IC's used in a wide variety of linear applications (figure 47). The circuit is basically a balanced amplifier in which the currents to the emitter-coupled differential pair of transistors are supplied from a constant-current source, such

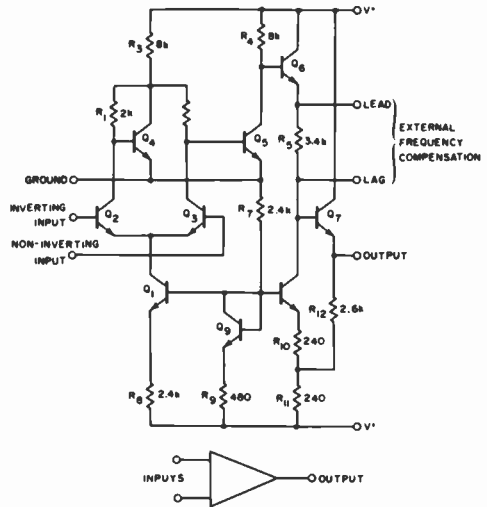

Figure 48

OPERATIONAL INTEGRATED-CIRCUIT AMPLIFIER

as a transistor. An *operational amplifier* is a high-gain direct-coupled amplifier utilizing frequency compensation (feedback) for control of response characteristics (figure 48). The circuit symbol for these amplifiers is a triangle, with the apex pointing in the direction of operation.

Integrated circuits may be used in communication as replacements for discrete components and are used at d-c, audio, and radio frequencies. Some typical IC schematics are shown in figure 49, and a printed-circuit regulator board using multiple IC's is shown in figure 50.

5-9 Silicon Power Transistors

Most high-frequency power transistors are silicon, planar, diffused NPN structures having a high ratio of active to physical area. Upwards of 200 watts average power at frequencies in the neighborhood of 800 MHz may be handled by modern silicon power transistors of advanced design. In the coming decade the efficiency, power gain, and temperature stability of these devices will lead to their use in many

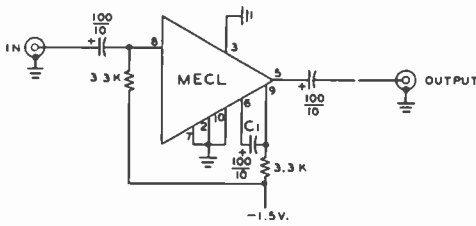

(A) AUDIO AMPLIFIER

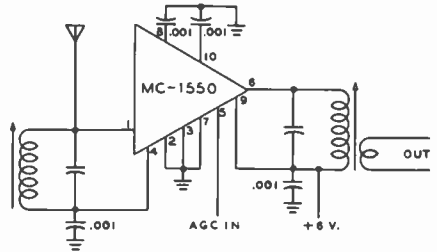

(B) R-F AMPLIFIER

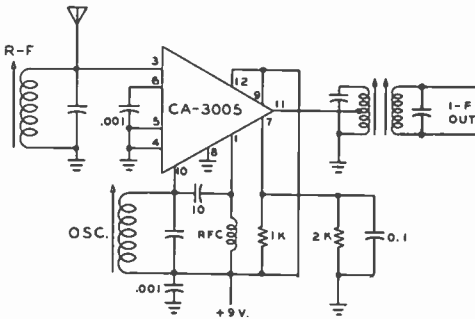

(C) R-F MIXER-OSC.

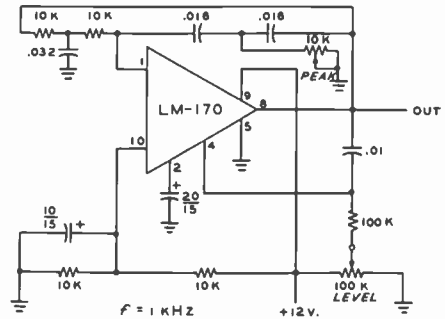

(D) AUDIO OSCILLATOR

Figure 49

IC R-F AND AUDIO AMPLIFIERS AND AUDIO OSCILLATOR

Integrated circuit combines functions of many transistors and associated components into one small package.

r-f amplifier applications heretofore solely reserved for electron tubes.

Circuit Considerations The power output capability of a transistor is determined by current and voltage limitations at the frequency of operation. The maximum current capacity is limited by emitter area and layer resistivity, and the voltage-handling capacity is limited by maximum breakdown limits imposed by layer resistivity and by the penetration of the junction. The *high-frequency current gain* figure of merit (f_T) defines the frequency at which the current gain is unity, and a high value of f_T at high emitter or collector current levels characterize a good r-f transistor.

In many cases, components and construction techniques used for vacuum tubes are

not appropriate for transistor circuits. This variance in circuit considerations results mainly because of the lower circuit impedances encountered in transistor circuits. The most troublesome areas are power dissipation and parasitic oscillation. In the case of power dissipation, the levels reached under a given r-f power input are considerably higher than equivalent levels achieved under d-c operating conditions, since the junction temperature is a complex function of device dissipation, which includes r-f losses introduced in the pellet mounting structure. The package, then, is an integral part of the r-f power transistor having thermal, capacitive, and inductive properties. The most critical parasitic features of the package are the emitter and base lead inductances. These undesired parameters can lead to parasitic oscillations, most of

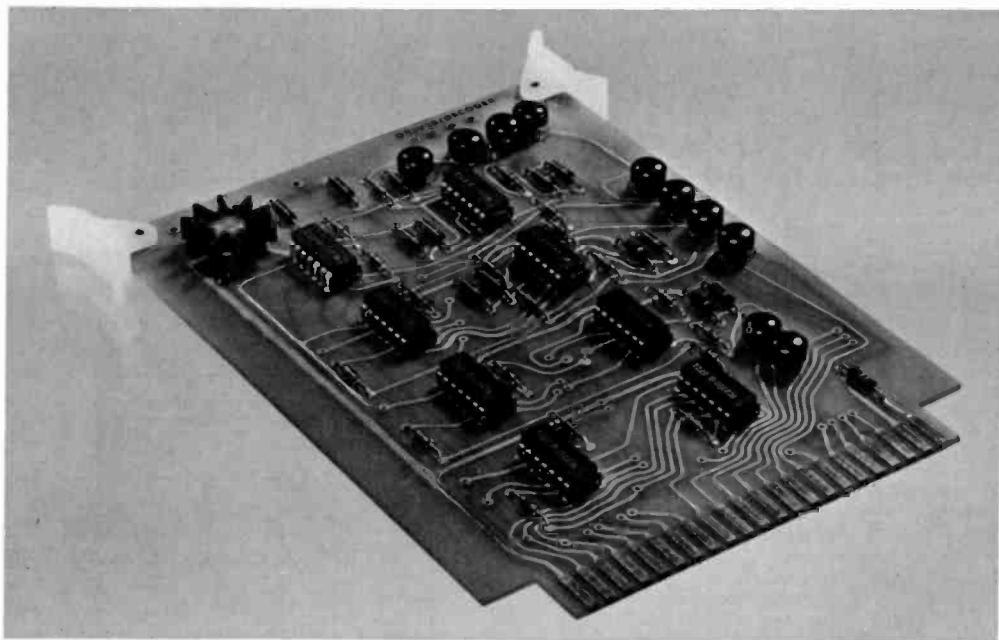

Figure 50

I-C CIRCUIT BOARD PERFORMS AS VOLTAGE REGULATOR

Complicated circuitry is reduced to printed-circuit board, eight "in-line" IC's and ten TO-5 style IC's. Transistor version would occupy many times this volume and have hundreds of discrete components. Final voltage regulator IC is at left with heat sink.

which occur at frequencies *below* the frequency of operation because of the increased gain of the transistor at lower frequencies. Because transistor parameters change with power level, instabilities can be found in both common-emitter and common-base circuits. Some of the more common difficulties are listed below:

Parametric Oscillation—Parametric instability results because the transistor collector-base capacitance is nonlinear and can cause low-frequency modulation of the output frequency. This effect can be suppressed by careful selection of the bypass capacitors, and by the addition of a low-frequency bypass capacitor in addition to the high-frequency bypass capacitor (figure 52).

Low Frequency Oscillation—With transistor gain decreasing at about 6 decibels per octave, any parasitic low-frequency circuit can cause oscillation. Inadequate bypassing plus the use of high-*Q*, resonant r-f chokes can lead to this difficulty. This effect can

be eliminated by placing small resistances in series with the r-f choke, or by the use of low-*Q* chokes of the ferrite-bead variety.

Hysteresis—Hysteresis refers to discontinuous mode jumps in output power that occur when the input power or operating frequency is increased or decreased. This is caused by dynamic detuning resulting from nonlinear junction capacitance variation with change in r-f voltage. The tuned circuit, in other words, will have a different resonant frequency for a strong drive signal than for a weak one. Usually, these difficulties can be eliminated or minimized by careful choice of base bias, by proper choice of ground connections, and by the use of transistors having minimum values of parasitic capacitance and inductance. Circuit wiring should be short and direct as possible and all grounds should be concentrated in a small area to prevent chassis inductance from causing common-impedance gain degeneration in the emitter circuit. In com-

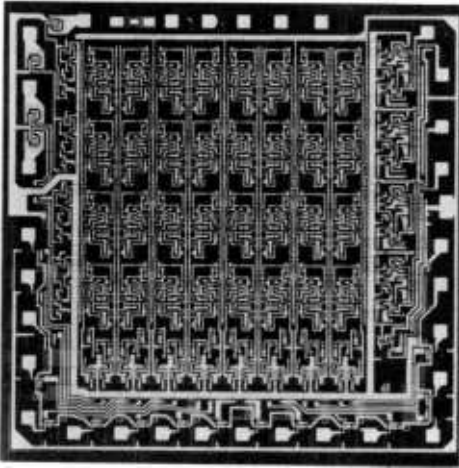

Figure 51

INTEGRATED CIRCUIT ASSEMBLY

This 36-lead integrated circuit complex is smaller than a postage stamp and includes 285 gates fabricated on a single chip. It is used for access to computer memory circuits. (Fairchild TTμL 9035).

mon-emitter circuits, stage gain is dependent on series emitter impedance and small amounts of degeneration can cause reduced circuit gain at the higher frequencies and permit unwanted feedback between output and input circuits.

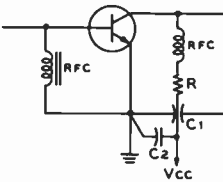

Figure 52

POWER-LEAD BYPASSING IN TRANSISTOR CIRCUITRY

Low-frequency oscillations can often be traced to inadequate bypassing and inadequate isolation of power leads or self-resonance of r-f chokes. Ferrite-bead chokes, or low-Q chokes are suggested. Collector choke may have low value of added series resistance used to de-Q it. Collector bypass capacitor is of the feedthrough type having a very high self-resonant frequency (C₁) in parallel with a high-capacitance unit to provide adequate bypassing at the lower frequencies (C₂).

Input Circuits Once the dynamic input impedance has been determined from published data or from measurements, the input circuit may be designed. In practice, the input circuit must provide a match between a source impedance that is high compared to the input impedance of the transistor, which may be of the order of a few tenths of an ohm. Lumped LC circuits are used in the high-frequency region and air-line or strip-line circuits are used in the vhf region, as shown in figure 53.

The reactive portion of the input circuit is a function of the transistor package inductance and the chip capacitance; at the lower frequencies the input impedance is capacitive, and at the higher frequencies it becomes inductive; at some discrete intermediate frequency, it is entirely resistive. The inductive reactance present at the higher frequencies may be tuned out by means of a line section presenting capacitive reactance to the transistor. This advantageously results in an appreciable increase in over-all line length, as compared to the more common quarter-wave matching transformer (figure 53D).

Output Circuits In most transistor power amplifiers, the lead impedance (R_L) presented to the collector is dictated by the required power output and the allowable peak d-c collector voltage, and thus is not made equal to the output resistance of the transistor. The peak a-c voltage is always less than the supply voltage and the collector load resistance may be expressed as:

$$R_L = \frac{(V_{CC})^2}{2 \times P_o}$$

where,

V_{CC} equals supply voltage,

P_o equals average power output.

The nonlinear transfer characteristic of the transistor and the large dynamic voltage and current swings result in high-level harmonic currents being generated in the collector circuit. These currents must be suppressed by proper design of the output coupling network, which offers a relatively

Figure 53

COMMON-EMITTER INPUT CIRCUITRY

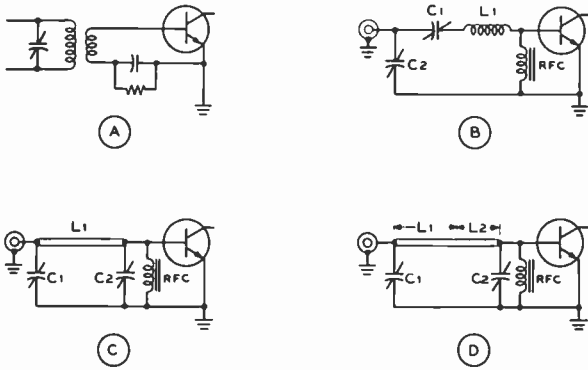

Gain of common-emitter circuit is very dependent on emitter series impedance which should be low. Base input impedance is usually less than one ohm and a matching circuit must be provided for a source impedance that is high compared to input impedance. A low-impedance inductive circuit (A) may be used, or various tuned networks that combine impedance transformation with rejection of harmonic frequencies (B). A linear pi network is shown at C. If the input circuit is inductive, the reactance may be tuned out by means of a line section (L_1) that presents a capacitive reactance to the transistor (D).

high impedance to the harmonic currents and a low impedance to the fundamental current (figure 54). Parallel-tuned, or pi-network circuitry may be used, with the reactive component of the output admittance tuned out by proper design of the series choke (RFC₁). At the lower frequencies, the collector of the transistor may be tapped down the tank coil as shown in the illustration. Capacitor C₁ provides tuning, and capacitor C₂ provides load matching. If the value of the inductor is properly chosen, harmonic suppression may be adequate. A form of this circuit is shown in figure 55, which provides better harmonic suppression with proper collector-circuit loading.

Mode of Operation From the stability standpoint, the common-emitter configuration provides a more stable circuit at the higher frequencies than does the common-base circuit. Collector efficiency in either case is about the same. Generally speaking, breakdown voltages under r-f conditions are considerably lower than the normal d-c breakdown voltages, and the capability of the r-f power transistor to work into loads having a high value of SWR is limited. A well-designed circuit operated at low supply voltage where power gain is not excessive is found to be less prone to SWR mismatch. High values of SWR mismatch lead to excessive r-f peak voltages, poor efficiency, and instability.

Single-sideband, linear operation calls for class-AB transistor operation. Most high-frequency power transistors are designed for on-off (class-C) operation and the forward bias necessary to place them in a class-AB mode leaves them susceptible to *second breakdown*, a destructive phenomenon characterized by localized heating within the transistor pellet, which leads to a regenerative layer damage.

Second breakdown may be controlled by the addition of emitter resistance of low value. A compromise amount is usually chosen as excessive emitter resistance can limit power gain and output. Developmental transistors designed for linear amplifier service have emitter resistance in the chip, in amounts of a fraction of an ohm. Other

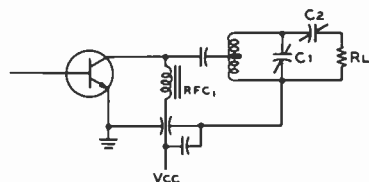

Figure 54

TRANSISTOR OUTPUT MATCHING CIRCUITRY

The reactive component of the output circuit of the transistor stage may be tuned out by proper design of the collector r-f choke (RFC₁). Tuning is accomplished by capacitor C₁, and load matching by capacitor C₂.

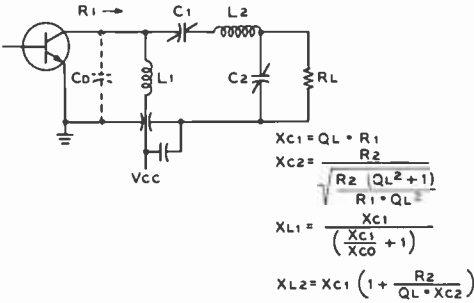

Figure 55

TRANSISTOR OUTPUT COUPLING NETWORK

This circuit provides proper collector loading and suppresses collector harmonic currents. The formulas for determination of constants are given in the illustration.

transistor types may incorporate a zener diode on the chip to provide controlled, positive base voltage.

The forward bias must, in any event, be maintained over a wide temperature range to prevent an increase in idling current accompanied by a rise in chip temperature, which leads to a destructive runaway condition under maximum output conditions when transistor temperature is highest.

A typical transistor linear amplifier and temperature-compensating base-bias circuit is shown in figure 56. Amplifiers of this configuration are capable of an output power in excess of 100 watts PEP from a 28-volt power supply at frequencies as high as 30 MHz. The input impedance of the transistor is of the order of 3 ohms at the operating frequency, and base bias is obtained from an auxiliary r-f driven circuit which compensates for the change in capacitance in the base-emitter junction of the power transistor under drive conditions. Any such change alters the bias point of the circuit

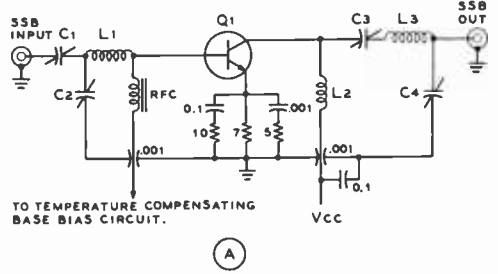

(A)

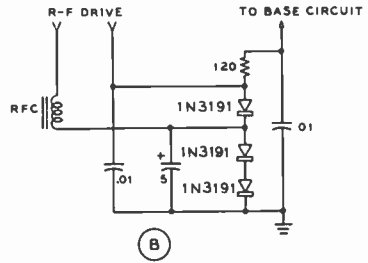

(B)

Figure 56

SSB LINEAR AMPLIFIER

A—Linear operation of transistor requires use of positive base bias for NPN silicon unit. Class-AB bias must be maintained over a wide range of temperature to hold idling current steady. External base bias compensating circuit is often used, plus emitter bias. Emitter resistor must be bypassed with low-impedance circuit to prevent spurious resonance effects. B—Temperature compensated base bias system employing temperature compensated diodes. Control is derived from rectification of drive signal.

and drives the transistor toward class-C operation, thus increasing the intermodulation distortion. This effect increases with chip temperature and power level. Additional information on transistor linear amplifiers is contained in the *RCA Silicon Power Circuits Manual (SP-50)*, published by the Electronics and Devices Division, Radio Corporation of America, Harrison, N.J.

Vacuum-Tube Amplifiers

6-1 Vacuum-Tube Parameters

The ability of the control grid of a vacuum tube to control large amounts of plate power with a small amount of grid energy allows the vacuum tube to be used as an amplifier. It is this ability of vacuum tubes to amplify an extremely small amount of energy up to almost any level, without change in anything except amplitude, which makes the vacuum tube such an extremely valuable adjunct to modern electronics and communication.

Symbols for Vacuum-Tube Parameters As an assistance in simplifying and shortening expressions involving vacuum-tube parameters, the symbols used throughout this book are shown in the Glossary at the front of this book.

Vacuum-Tube Constants The relationships between certain of the electrode potentials and currents within a vacuum tube are reasonably constant under specified conditions of operation. These relationships are called *vacuum-tube constants* and are listed in the data published by the manufacturers of vacuum tubes. The defining equations for the basic vacuum-tube constants are given in Chapter Four.

Interelectrode Capacitances and Miller Effect The values of interelectrode capacitance published in vacuum-tube tables are the static values measured, in the case of triodes for example, as shown in figure 1. The static capacitances are simply as shown in the drawing, but when a tube is operating as amplifier there is another consideration known as *Miller Effect* which causes the dynamic input capacitance to be different from the static value. The output capacitance of an amplifier is essentially the same as the static value given in the published tube tables. The grid-to-plate capacitance is also the same as the published static value, but since C_{gp} acts as a small capacitance coupling energy back from the plate circuit to the grid circuit, the dynamic input capacitance is equal to the static value plus an amount (frequently much greater in the case of a triode) determined by the gain of the stage, the plate load impedance, and the C_{gp} feedback capacitance. The total

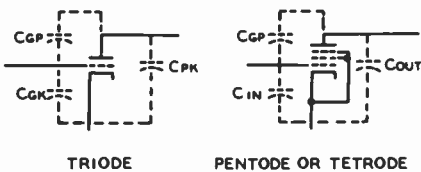

Figure 1

STATIC INTERELECTRODE CAPACITANCES WITHIN A TRIODE, PENTODE, OR TETRODE

value for an audio-amplifier stage can be expressed in the following equation:

$$C_{gk(\text{dynamic})} = C_{gk(\text{static})} + (A + 1) C_{gp}$$

This expression assumes that the vacuum tube is operating into a resistive load such as would be the case with an audio stage working into a resistance plate load in the middle audio range.

The more complete expression for the input admittance (vector sum of capacitance and resistance) of an amplifier operating into any type of plate load is as follows:

$$\text{input capacitance} = C_{gk} + (1 + A \cos \theta) C_{gp}$$

$$\text{input resistance} = -\left(\frac{1}{\omega C_{gp}}\right) \frac{A' \sin \theta}{A' \sin \theta}$$

where,

A' equals voltage amplification of the tube alone,

θ equals angle of the plate-load impedance, positive for inductive loads, negative for capacitive.

It can be seen from the above that if the plate-load impedance of the stage is capacitive or inductive, there will be a resistive component in the input admittance of the stage. The resistive component of the input admittance will be positive (tending to load the circuit feeding the grid) if the load impedance of the plate is capacitive, or it will be negative (tending to make the stage oscillate) if the load impedance of the plate is inductive.

Neutralization of Interelectrode Capacitance Neutralization of the effects of interelectrode capacitance is employed most frequently in the case of radio-frequency power amplifiers. Before the introduction of the tetrode and pentode tube, triodes were employed as neutralized class-A amplifiers in receivers. Except for vhf operation of low-noise triodes, this practice has been largely superseded through the use of tetrode and pentode tubes in which the C_{gp} or feedback capacitance has been reduced to such a low value that neutralization of its effects is not necessary to prevent oscillation and instability.

6-2 Classes and Types of Vacuum-Tube Amplifiers

Vacuum-tube amplifiers are grouped into various classes and subclasses according to the type of work they are intended to perform. The difference between the various classes is determined primarily by the angle of plate-current flow, the value of average grid bias employed, and the maximum value of the exciting signal to be impressed on the grid.

Class-A Amplifier A class-A amplifier is an amplifier biased and supplied with excitation of such amplitude that plate current flows continuously (360° of the exciting voltage waveshape) and grid current does not flow at any time. Such an amplifier is normally operated in the center of the grid-voltage plate-current transfer characteristic and gives an output waveshape which is a substantial replica of the input waveshape.

Class-A operation is employed in most small-signal applications such as in receivers and exciters. This mode of operation is characterized by high gain, low distortion, and low efficiency. Class-A mode may be further subdivided into A_1 and A_2 operation signifying the degree of grid drive on the stage, with the A_2 mode signifying grid drive approaching the class- AB_1 mode.

Class- AB_1 Amplifier Class- AB_1 signifies an amplifier operated under such conditions of grid bias and exciting voltage that plate current flows for more than one-half the input voltage cycle but for less than the complete cycle. In other words the operating angle of plate current flow is appreciably greater than 180° but less than 360°. The suffix $_1$ indicates that grid current does not flow over any portion of the input cycle.

Class- AB_1 operation is utilized in most high quality, medium-power audio amplifiers and linear r-f amplifiers. Gain is lower and distortion higher than for class-A amplifiers.

Class- AB_2 Amplifier A Class- AB_2 amplifier is operated under essentially the same conditions of grid bias as the class- AB_1

amplifier mentioned above, but the exciting voltage is of such amplitude that grid current flows over an appreciable portion of the input wave cycle.

Class-B Amplifier A class-B amplifier is biased substantially to cutoff of plate current (without exciting voltage) so that plate current flows essentially over one-half the input voltage cycle. The operating angle of plate-current flow is 180° . The class-B amplifier is usually excited to the extent that grid current flows.

Class-C Amplifier A class-C amplifier is biased to a value greater than the value required for plate-current cutoff and is excited with a signal of such amplitude that grid current flows over an appreciable period of the input-voltage waveshape. The angle of plate-current flow in a class-C amplifier is appreciably less than 180° , or in other words, plate current flows less than one-half the time. Class-C amplifiers are not capable of linear amplification as their output waveform is not a replica of the input voltage for all signal amplitudes.

Types of Amplifiers There are three general types of amplifier circuits in use. These types are classified on the basis of the return for the input and output circuits. Conventional amplifiers are called *grid-driven* amplifiers, with the cathode acting as the common return for both the input and output circuits. The second type is known as a plate-return amplifier or *cathode*

follower since the plate circuit is effectively at ground for the input and output signal voltages and the output voltage or power is taken between cathode and plate. The third type is called a *cathode-driven* or *grounded-grid* amplifier since the grid is effectively at ground potential for input and output signals and output is taken between grid and plate (see figure 19, chapter 5).

6-3 Biasing Methods

The difference in average potential between grid and cathode is called the *grid bias* of a vacuum tube. There are three general methods of providing this bias voltage. In each of these methods the purpose is to establish the grid at a potential with respect to the cathode which will place the tube in the desired operating condition as determined by its characteristics.

Grid bias may be obtained from a source of voltage specially provided for this purpose, such as a battery or other d-c power supply. This method is illustrated in figure 2A, and is known as *fixed bias*.

A second biasing method is illustrated in figure 2B which utilizes a cathode resistor across which an *IR* drop is developed as a result of plate current flowing through it. The cathode of the tube is held at a positive potential with respect to ground by the amount of the *IR* drop because the grid is at ground potential. Since the biasing voltage depends on the flow of plate current the tube cannot be held in a cutoff condition by means of the *cathode bias* voltage developed across the cathode resistor. The value of this resistor is determined by the bias required and the plate current which flows at this value of bias, as found from the tube characteristic curves. A capacitor is shunted across the bias resistor to provide a low-impedance path to ground for the a-c component of the plate current which results from an a-c input signal on the grid.

The third method of providing a biasing voltage is shown in figure 2C, and is called *grid-resistor bias*. During the portion of the input cycle which causes the grid to be positive with respect to the cathode, grid current flows from cathode to grid, charging capacitor C_c . When the grid draws current, the grid-to-cathode resistance of the tube

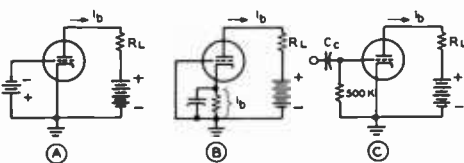

Figure 2

TYPES OF BIAS SYSTEMS

- A - Grid bias
- B - Cathode bias
- C - Grid resistor bias

drops from an infinite value to a very low value (on the order of 1000 ohms or so) making the charging time constant of the capacitor very short. This enables C_C to charge up to essentially the full value of the positive input voltage and results in the grid (which is connected to the low-potential plate of the capacitor) being held essentially at ground potential. During the negative swing of the input signal no grid current flows and the discharge path of C_C is through the grid resistance which has a value of 500,000 ohms or so. The discharge time constant for C_C is, therefore, very long in comparison to the period of the input signal and only a small part of the charge on C_C is lost. Thus, the bias voltage developed by the discharge of C_C is substantially constant and the grid is not permitted to follow the positive portion of the input signal.

6-4 Distortion in Amplifiers

There are three main types of distortion that may occur in amplifiers: *frequency distortion*, *phase distortion* and *amplitude distortion*.

Frequency Distortion *Frequency distortion* may occur when some frequency components of a signal are amplified more than others. Frequency distortion occurs at low frequencies if coupling capacitors between stages are too small, or it may occur at high frequencies as a result of the shunting effects of the distributed capacities in the circuit.

Phase Distortion In figure 3 an input signal consisting of a fundamental and a third harmonic is passed through a two-stage amplifier. Although the amplitudes of both components are amplified by identical ratios, the output waveshape is considerably different from the input signal because the phase of the third-harmonic signal has been shifted with respect to the fundamental signal. This phase shift is known as *phase distortion*, and is caused principally by the coupling circuits between the stages of the amplifier. Most coupling circuits shift the phase of a sine wave, but this has no effect on the shape of the output wave. However, when a complex wave

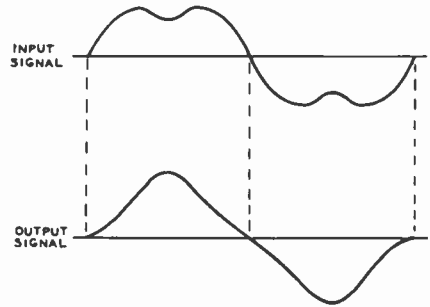

Figure 3

Illustration of the effect of phase distortion on input wave containing a third-harmonic signal

is passed through the same coupling circuit each component frequency of the wave shape may be shifted in phase by a different amount so that the output wave is not a faithful reproduction of the input waveshape.

Amplitude Distortion If a signal is passed through a vacuum tube that is operating on any nonlinear part of its characteristic, *amplitude distortion* will occur. In such a region, a change in grid voltage does not result in a change in plate current which is directly proportional to the change in grid voltage. For example, if an amplifier is excited with a signal that overdrives the tubes, the resultant signal is distorted in amplitude, since the tubes are then operating over a nonlinear portion of their characteristic.

6-5 Resistance-Capacitance Coupled Audio-Frequency Amplifiers

Present practice in the design of audio-frequency voltage amplifiers is almost ex-

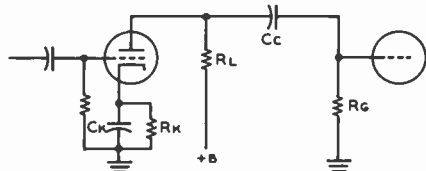

Figure 4

STANDARD CIRCUIT FOR RESISTANCE-CAPACITANCE COUPLED TRIODE AMPLIFIER STAGE

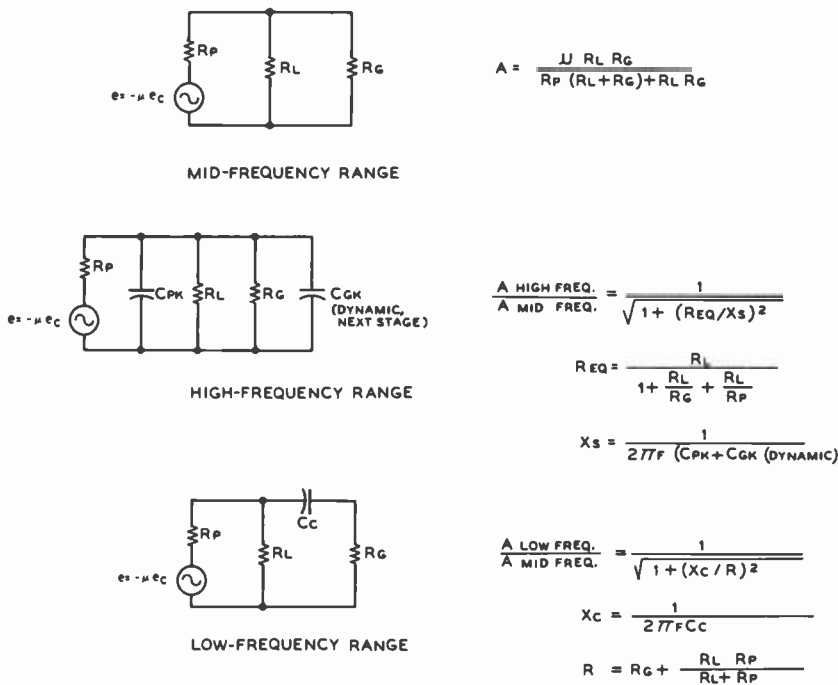

Figure 5

Equivalent circuits and gain equations for a triode RC-coupled amplifier stage. In using these equations, be sure the values of μ and R_p are proper for the static current and voltages with which the tube will operate. These values may be obtained from curves published in the RCA Receiving Tube Manual (series RC).

clusively to use resistance-capacitance coupling between the low-level stages. Both triodes and pentodes are used; triode amplifier stages will be discussed first.

RC-Coupled Triode Stages Figure 4 illustrates the standard circuit for a resistance-capacitance coupled amplifier stage utilizing a triode tube with cathode bias. In conventional audio-frequency amplifier design such stages are used at medium voltage levels (from 0.01 to 5 volts peak on the grid of the tube) and use medium- μ triodes such as the 6C4 or high- μ triodes such as the 6AB4 or 12AT7. Normal voltage gain for a single stage of this type is from 10 to 70, depending on the tube chosen and its operating conditions. Triode tubes are normally used in the last voltage-amplifier stage of an RC amplifier since their harmonic distortion with large output volt-

age (25 to 75 volts) is less than with a pentode tube.

Voltage Gain per Stage The voltage gain per stage of a resistance-capacitance coupled triode amplifier can be calculated with the aid of the equivalent circuits and expressions for the mid-frequency, high-frequency, and low-frequency ranges given in figure 5.

A triode RC-coupled amplifier stage is normally operated with values of cathode resistor and plate-load resistor such that the actual voltage on the tube is approximately one-half the d-c plate-supply voltage. To assist the designer of such stages, data on operating conditions for commonly used tubes is published in the RCA Receiving Tube Manual. It is assumed, in the case of the gain equations of figure 5, that the cathode bypass capacitor (C_k) has a reactance

that is low with respect to the cathode resistor at the lowest frequency to be passed by the amplifier stage.

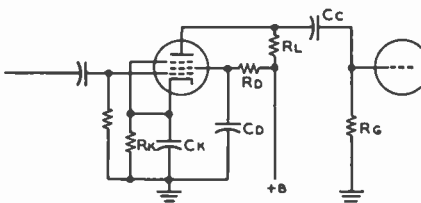

Figure 6

STANDARD CIRCUIT FOR RESISTANCE-CAPACITANCE COUPLED PENTODE AMPLIFIER STAGE

RC Coupled Pentode Stages Figure 6 illustrates the standard circuit for a resistance-capacitance coupled pentode amplifier stage. Cathode bias is used and the screen voltage is supplied through a dropping resistor from the plate-voltage supply. In conventional audio-frequency amplifier design such stages are normally used at low voltage levels (from 0.00001 to 0.1 volts peak on the grid of the tube) and use moderate- G_m pentodes such as the 6AU6. Normal voltage gain for a stage of this type is from 60 to 250, depending on the tube chosen and its operating conditions. Pentode tubes are ordinarily used in the first stage of an RC amplifier, where the high gain which they afford is of greatest advantage, and where only a small voltage output is required from the stage.

The voltage gain per stage of a resistance-capacitance coupled pentode amplifier can be calculated with the aid of the equivalent circuits and expressions for the mid-frequency, high-frequency, and low-frequency ranges given in figure 7.

To assist the designer of such stages, data on operating conditions for commonly used types of tubes is published in the RCA Receiving Tube Manual, RC-series. It is assumed, in the case of the gain equations of figure 7, that cathode bypass capacitor C_k has a reactance that is low with respect to the cathode resistor at the lowest frequency to be passed by the stage. It is additionally assumed that the reactance of screen bypass capacitor C_d is low with respect to screen

dropping resistor R_d at the lowest frequency to be passed by the amplifier stage.

Cascaded Voltage Amplifier Stages When voltage-amplifier stages are operated in such a manner that the output voltage of the first is fed to the grid of the second, and so forth, such stages are said to be *cascaded*. The total voltage gain of cascaded amplifier stages is obtained by taking the product of the voltage gains of each of the successive stages.

Sometimes the voltage gain of an amplifier stage is rated in decibels. Voltage gain is converted into decibel gain through the use of the following expression: $db = 20 \log_{10} A$, where A is the voltage gain of the stage. The total gain of cascaded voltage-amplifier stages can be obtained by *adding* the number of db gain in each of the cascaded stages.

RC Amplifier Response A typical frequency-response curve for an RC-coupled audio amplifier is shown in figure 8.

It is seen that the amplification is poor for the extreme high and low frequencies. The reduced gain at the low frequencies is caused by the loss of voltage across the coupling capacitor. In some cases, a low-value coupling capacitor is deliberately chosen to reduce the response of the stage to hum, or to attenuate the lower voice frequencies for communication purposes. For high-fidelity work the product of the grid resistor in ohms times the coupling capacitor in microfarads should equal 25,000 (i.e.: $500,000 \text{ ohms} \times 0.05 \text{ } \mu\text{fd} = 25,000$).

The amplification of high frequencies falls off because of the Miller effect of the subsequent stage, and the shunting effect of residual circuit capacities. Both of these effects may be minimized by the use of a low-value plate-load resistor.

Grid-resistor Bias for High-Mu Triodes The correct operating bias for a high- μ triode such as the 12AT7, is fairly critical, and will be found to be highly variable from tube to tube because of minute variations in contact potential within the tube itself. A satisfactory bias method is to use grid-resistor bias, with a resistor of one to ten megohms connected

Figure 7

Equivalent circuits and gain equations for a pentode RC-coupled amplifier stage. In using these equations be sure to select the values of g_m and R_p which are proper for the static currents and voltages with which the tube will operate. These values may be obtained from curves published in the RCA Receiving Tube Manual Series RC.

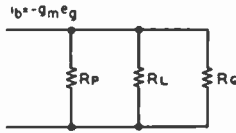

MID-FREQUENCY RANGE

$$A = G_m R_{EQ}$$

$$R_{EQ} = \frac{R_L}{1 + \frac{R_L}{R_C} + \frac{R_L}{R_P}}$$

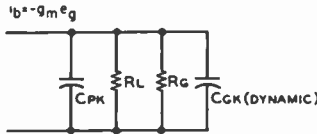

HIGH-FREQUENCY RANGE

$$\frac{A_{HIGH\ FREQ}}{A_{MID\ FREQ}} = \frac{1}{\sqrt{1 + (R_{EQ}/X_s)^2}}$$

$$R_{EQ} = \frac{R_L}{1 + \frac{R_L}{R_C} + \frac{R_L}{R_P}}$$

$$X_s = \frac{1}{2\pi f (C_{PK} + C_{GK} (DYNAMIC))}$$

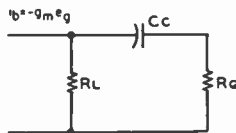

LOW-FREQUENCY RANGE

$$\frac{A_{LOW\ FREQ.}}{A_{MID\ FREQ.}} = \frac{1}{\sqrt{1 + (X_C/R)^2}}$$

$$X_C = \frac{1}{2\pi f C_C}$$

$$R = R_G + \frac{R_L R_P}{R_L + R_P}$$

directly between grid and cathode of the tube with the cathode grounded. Grid current flows at all times, and the effective input resistance is about one-half the resistance value of the grid resistor. This circuit is particularly well suited as a high-gain amplifier following low-output devices, such as crystal, or dynamic microphones.

RC Amplifier

General Characteristics

A resistance - capacitance coupled amplifier can be designed to provide a good frequency response for

almost any desired range. For instance, such an amplifier can be built to provide a fairly

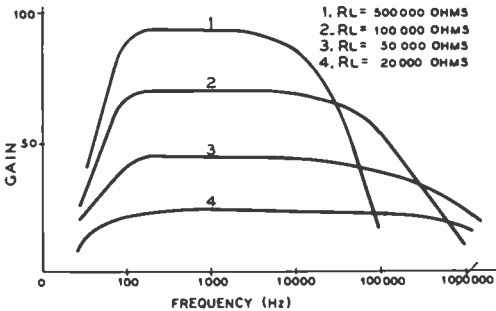
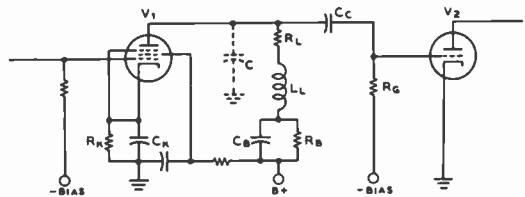

Figure 8

The variation of stage gain with frequency in an RC-coupled pentode amplifier for various values of plate load resistance.



MID-FREQUENCY GAIN = $G_m V_1 R_L$

HIGH-FREQUENCY GAIN = $G_m V_1 Z_{COUPLING\ NETWORK}$

$C = C_{OUT\ V_1} + C_{IN\ V_2} + C_{DISTRIBUTED}$

FOR COMPROMISE HIGH-FREQUENCY EQUALIZATION

$X_{LL} = 0.5 X_C \text{ AT } f_C$

$R_L = X_C \text{ AT } f_C$

WHERE f_C = CUTOFF-FREQUENCY OF AMPLIFIER

L_L = PEAKING INDUCTOR

FOR COMPROMISE LOW-FREQUENCY EQUALIZATION

$R_B = R_K (G_m V_1 R_L)$

$R_B C_B = R_K C_K$

$C_K = 25 \text{ TO } 50 \mu F$ IN PARALLEL WITH 001 MIC

C_B = CAPACITANCE FROM ABOVE WITH 001 MIC IN PARALLEL

Figure 9

SIMPLE COMPENSATED VIDEO AMPLIFIER CIRCUIT

Resistor R_L in conjunction with coil L_L serves to flatten the high-frequency response of the stage, while C_B and R_B serve to equalize the low-frequency response of this simple video amplifier stage.

uniform amplification for frequencies in the audio range of about 100 to 20,000 Hz. Changes in the values of coupling capacitors and load resistors can extend this frequency range to cover the very wide range required for video service. However, extension of the range can only be obtained at the cost of reduced over-all amplification. Thus RC coupling allows good frequency response with minimum distortion, but low amplification. Phase distortion is less with RC coupling than with other types, except direct coupling. The RC amplifier may exhibit tendencies to *motorboat* or oscillate if it is used with a high-impedance plate supply.

6-6 Video-Frequency Amplifiers

A *video-frequency amplifier* is one which has been designed to pass frequencies from the lower audio range (lower limit perhaps 50 Hz) to the middle r-f range (upper limit perhaps 4 to 6 MHz). Such amplifiers, in addition to passing such an extremely wide frequency range, must be capable of amplifying this range with a minimum of amplitude, phase, and frequency distortion. Video amplifiers are commonly used in television, pulse communication, and radar work.

Tubes used in video amplifiers must have a high ratio of G_m to capacitance if a usable gain per stage is to be obtained. Commonly available tubes which have been designed for or are suitable for use in video amplifiers are: 6AU6, 6AG5, 6AK5, 6CB6, 6BC5, 6DE6, and 6AH6. Since, at the upper frequency limits of a video amplifier the input and output shunting capacitances of the amplifier tubes have rather low values of reactance, low values of coupling resistance, along with peaking coils or other special interstage coupling impedances, are usually used to flatten out the gain/frequency and hence the phase/frequency characteristic of the amplifier. Recommended operating conditions along with expressions for calculation of gain and circuit values are given in figure 9. Only a simple two-terminal interstage coupling network is shown in this figure.

The performance and gain per stage of a video amplifier can be improved by the use

of increasingly complex two-terminal interstage coupling networks or through the use of four-terminal coupling networks or filters between successive stages. The reader is referred to Terman's "*Radio Engineer's Handbook*" for design data on such interstage coupling networks.

6-7 Other Interstage Coupling Methods

Figure 10 illustrates, in addition to resistance-capacitance interstage coupling, seven additional methods in which coupling between two successive stages of an audio-frequency amplifier may be accomplished. Although RC coupling is most commonly used, there are certain circuit conditions wherein coupling methods other than RC are more effective.

Transformer Coupling *Transformer coupling*, as illustrated in figure 10B, is seldom used at the present time between two successive single-ended stages of an audio amplifier. There are several reasons why resistance coupling is favored over transformer coupling between two successive single-ended stages. These are: (1) a transformer having frequency characteristics comparable with a properly designed RC stage is very expensive; (2) transformers, unless they are very well shielded, will pick up inductive hum from nearby power and filament transformers; (3) the phase characteristics of step-up interstage transformers are poor, making very difficult the inclusion of a transformer of this type within a feedback loop; and (4) transformers are heavy.

However, there is one circuit application where a step-up interstage transformer is of considerable assistance to the designer; this is the case where it is desired to obtain a large amount of voltage to excite the grid of a cathode follower or of a high-power class-A amplifier from a tube operating at a moderate plate voltage. Under these conditions it is possible to obtain a peak voltage on the secondary of the transformer of a value somewhat greater than the d-c plate-supply voltage of the tube supplying the primary of the transformer.

Push-Pull Transformer Interstage Coupling *Push-pull transformer coupling* between two stages is illustrated in figure 10C. This interstage coupling arrangement is fairly commonly used. The system is particularly effective when it is desired, as in the system just described, to obtain a rather high voltage to excite the grids of a high-power audio stage. The arrangement is also very good when it is desired to apply feedback to the grids of the push-pull stage by applying the feedback voltage to the low-potential sides of the two push-pull secondaries.

Impedance Coupling *Impedance coupling* between two stages is shown in figure 10D.

This circuit arrangement is seldom used, but it offers one strong advantage over RC interstage coupling. This advantage is the fact that the operating voltage on the tube with the impedance in the plate circuit is equal to the plate-supply voltage, and it is possible to obtain approximately twice the peak voltage output that is possible to obtain with RC coupling. This is because, as has been mentioned before, the d-c plate voltage on an RC stage is approximately one-half the plate supply voltage.

Impedance-Transformer and Resistance-Transformer Coupling These two circuit arrangements, illustrated in figures 10E and 10F, are employed when it is desired to use transformer coupling for the reasons cited above, but where it is desired that the d-c plate current of the amplifier stage be isolated from the primary of the coupling transformer. With most types of high-permeability wide response transformers it is necessary that there be no d-c flow through the windings of the transformer. The impedance-transformer arrangement of figure 10E will give a higher voltage output from the stage but is not often used since the plate coupling impedance (choke) must have very high inductance and very low distributed capacitance in order not to restrict the range of the transformer which it and its associated tube feed. The resistance-transformer arrangement of figure 10F is ordinarily satisfactory where it is desired to feed a transformer from a voltage-amplifier stage with no direct current in the transformer primary.

Cathode Coupling The *cathode-coupling* arrangement of figure 10G has been widely used only comparatively recently. One outstanding characteristic of such a circuit is that there is no phase reversal between the grid and the plate circuit. All other common types of interstage coupling are accompanied by a 180° phase reversal between the grid circuit and the plate circuit of the tube.

Figure 11 gives the expressions for determining the appropriate factors for an equivalent triode obtained through the use of a pair of similar triodes connected in the cathode-coupled circuit shown. With these equivalent triode factors it is possible to use the expressions shown in figure 5 to determine the gain of the stage at different frequencies. The input capacitance of such a stage is less than that of one of the triodes, the effective grid-to-plate capacitance is very much less (it is so much less that such a stage may be used as an r-f amplifier without neutralization), and the output capacitance is approximately equal to the grid-to-plate capacitance of one of the triode sections. This circuit is particularly effective with tubes such as the 6J6, 12AU7, and 12AT7, which have two similar triodes in one envelope. An appropriate value of cathode resistor to use for such a stage is the value which would be used for the cathode resistor of a conventional amplifier using *one* of the same type tubes with the values of plate voltage and load resistance to be used for the cathode-coupled stage.

Inspection of the equations in figure 11 shows that as the cathode resistor is made smaller to approach zero, G_m approaches zero, the plate resistance approaches the R_p of one tube, and the μ approaches zero. Since the cathode resistor is made very large the G_m approaches one-half that of a single tube of the same type, the plate resistance approaches twice that of one tube, and the μ approaches the same value as one tube. But since the G_m of each tube decreases as the cathode resistor is made larger (the plate current will decrease on each tube) the optimum value of cathode resistor will be found to be in the vicinity of the value mentioned in the previous paragraph.

Direct Coupling *Direct coupling* between successive amplifier stages (plate

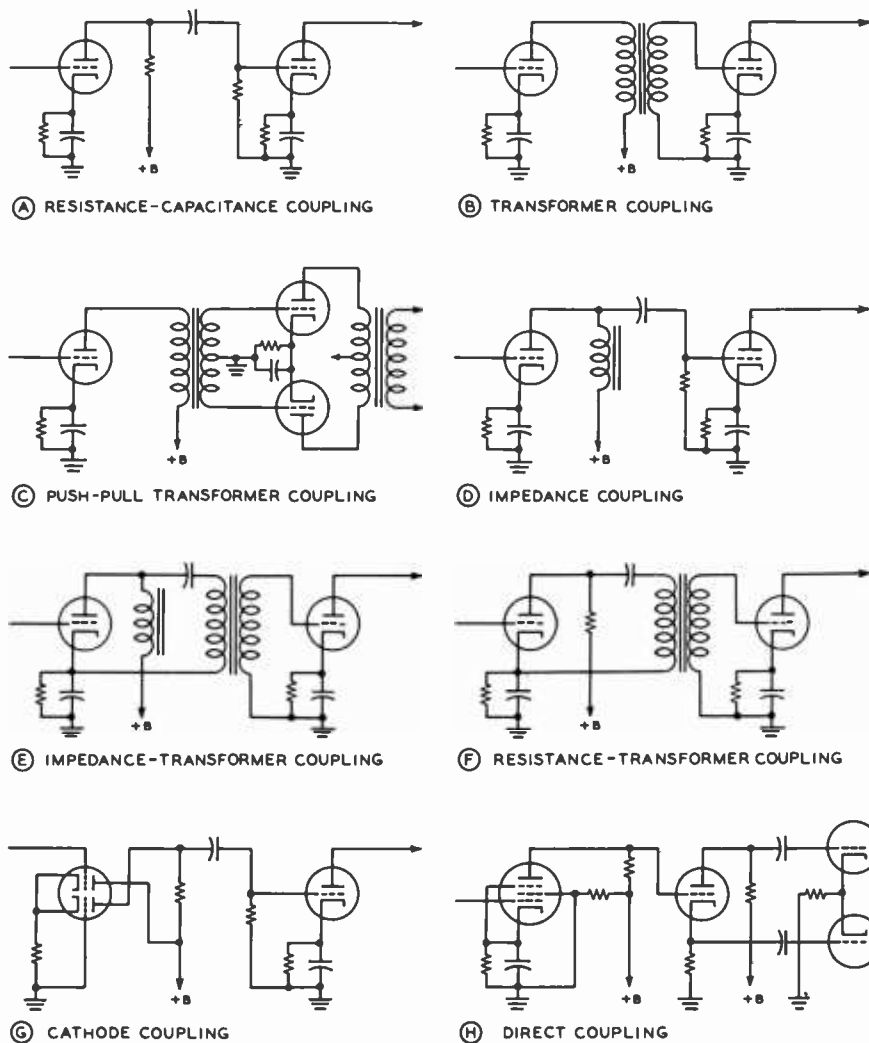
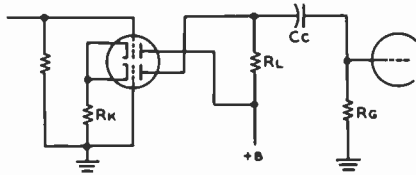

Figure 10

INTERSTAGE COUPLING METHODS FOR AUDIO-FREQUENCY VOLTAGE AMPLIFIERS

of first stage connected directly to the grid of the succeeding stage) is complicated by the fact that the grid of an amplifier stage must be operated at an average negative potential with respect to the cathode of that stage. However, if the cathode of the second amplifier stage can be operated at a potential more positive than the plate of the preceding stage by the amount of the grid bias on the second amplifier stage, this direct connection between the plate of one stage

and the grid of the succeeding stage can be used. Figure 10H illustrates an application of this principle in the coupling of a pentode amplifier stage to the grid of a *hot-cathode* phase inverter. In this arrangement the values of cathode, screen, and plate resistors in the pentode stage are chosen so that the plate of the pentode is at approximately one-third of the plate supply potential. The succeeding phase-inverter stage then operates with conventional values of cathode



$$G_m' = -G_m \frac{G}{2G+1} \quad G = R_k G_m \left(1 + \frac{1}{\mu}\right)$$

$$R_p' = R_p \frac{2G+1}{G+1} \quad R_k = \text{CATHODE RESISTOR}$$

$$\mu' = -\mu \frac{G}{G+1} \quad G_m = G_m \text{ OF EACH TUBE}$$

$$\mu = \mu \text{ OF EACH TUBE}$$

$$R_p = R_p \text{ OF EACH TUBE}$$

EQUIVALENT FACTORS INDICATED ABOVE BY (') ARE THOSE OBTAINED BY USING AN AMPLIFIER WITH A PAIR OF SIMILAR TUBE TYPES IN CIRCUIT SHOWN ABOVE.

Figure 11

Equivalent factors for a pair of similar triodes operating as a cathode-coupled audio-frequency voltage amplifier.

and plate resistor (same value of resistance) in its normal manner. This type of phase inverter is described in more detail in the section to follow.

6-8 Phase Inverters

In order to excite the grids of a push-pull stage it is necessary that voltages equal in amplitude and opposite in polarity be applied to the two grids. These voltages may be obtained through the use of a push-pull input transformer such as is shown in figure 10C. It is possible also, without the attendant bulk and expense of a push-pull input transformer, to obtain voltages of the proper polarity and phase through the use of a so-called *phase-inverter* stage. There are a large number of phase-inversion circuits which have been developed and applied but the three shown in figure 12 have been found over a period of time to be the most satisfactory from the point of view of the number of components required and from the standpoint of the accuracy with which the two out-of-phase voltages are held to the same amplitude with variations in supply voltage and changes in tubes.

All of these vacuum-tube phase inverters are based on the fact that a 180° phase shift occurs within a vacuum tube between the grid input voltage and the plate output voltage. In certain circuits, the fact that the grid input voltage and the voltage appearing

across the cathode bias resistor are in phase, is used for phase-inversion purposes.

“Hot-Cathode” Figure 12A illustrates the *hot-cathode* type of phase inverter. This phase inverter is the simplest of the three types since it requires only one tube and a minimum of circuit components. It is particularly simple when directly coupled from the plate of a pentode amplifier stage as shown in figure 10H. The circuit does, however, possess the following two disadvantages: (1) the cathode of the tube must run at a potential of approximately one-third the plate supply voltage above the heater when a grounded common heater winding is used for this tube as well as the other heater-cathode tubes in a receiver or amplifier; (2) the circuit actually has a loss in voltage from its input to either of the output grids—about 0.9 times the input voltage will be applied to each of these grids. This does represent a voltage gain of about 1.8 in *total* voltage output with respect to input (grid-to-grid output voltage) but it is still small with respect to the other two phase-inverter circuits shown.

Recommended component values for use with a 6C4 tube in this circuit are shown in figure 12A. If it is desired to use another tube in this circuit, appropriate values for the operation of that tube as a conventional amplifier can be obtained from manufacturer's tube data. The designated value of R_L should be divided by two, and this new value of resistance placed in the circuit as R_L . The value of R_k from tube-manual tables should then be used as R_{k1} in this circuit, and the total of R_{k1} and R_{k2} should be equal to R_L .

“Floating Paraphase” An alternate type of phase inverter sometimes called the *floating paraphase* is illustrated in figure 12B. This circuit is quite often used with a 12AU7 tube, and appropriate values for this tube in a typical inverter circuit are shown. Using the component values given will provide a voltage gain of approximately 12 from the input grid to each of the grids of the succeeding stage. It is capable of approximately 70 volts peak output to each grid.

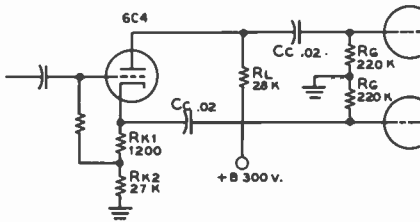

(A) "HOT-CATHODE" PHASE INVERTER

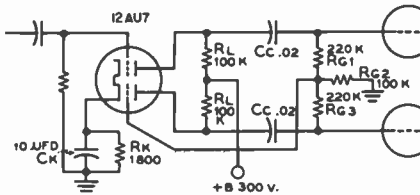

(B) "FLOATING PARAPHASE" PHASE INVERTER

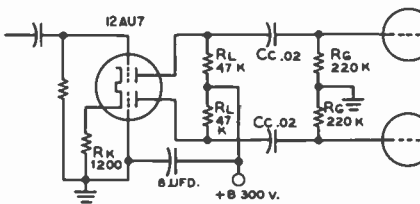

(C) CATHODE-COUPLED PHASE INVERTER

Figure 12

THREE TYPICAL PHASE-INVERTER CIRCUITS WITH RECOMMENDED VALUES FOR CIRCUIT COMPONENTS

The circuit inherently has a small unbalance in output voltage. This unbalance can be eliminated, if it is required for some special application, by making the resistor R_{g1} a few percent lower in resistance value than R_{g3} .

Cathode-Coupled Phase Inverter The circuit shown in figure 12C gives approximately one half the voltage gain from the input grid to either of the grids of the succeeding stage that would be obtained from a single tube of the same type operating as a conventional RC amplifier stage. Thus, with a 12AU7 tube as shown (two 6C4's in one envelope) the voltage gain from the input grid to either of the output grids will be approximately 7—the gain is, of course, 14 from the input to both

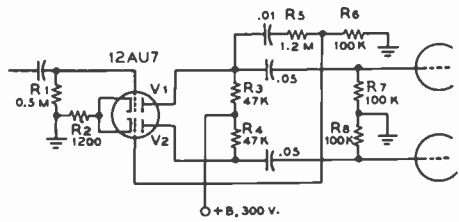

Figure 13

VOLTAGE-DIVIDER PHASE INVERTER

output grids. The phase characteristics are such that the circuit is commonly used in deriving push-pull deflection voltage for a cathode-ray tube from a single-ended input signal.

The first section of the 12AU7 is used as an amplifier to increase the amplitude of the applied signal to the desired level. The second section of the 12AU7 is used as an inverter and amplifier to produce a signal of the same amplitude but of opposite polarity. Since the common cathode resistor (R_k) is not bypassed the voltage across it is the algebraic sum of the two plate currents and has the same shape and polarity as the voltage applied to the input grid of the first half of the 12AU7. When a signal (e) is applied to the input circuit, the effective grid-cathode voltage of the first section is $Ae/2$, when A is the gain of the first section. Since the grid of the second section of the 12AU7 is grounded, the effect of the signal voltage across R_k (equal to $e/2$ if R_k is the proper value) is the same as though a signal of the same amplitude but of opposite polarity were applied to the grid. The output of the second section is equal to $-Ae/2$ if the plate load resistors are the same for both tube sections.

Voltage-Divider Phase Inverter A commonly used phase inverter is shown in figure 13. The input section (V_1) is connected as a conventional amplifier. The output voltage from V_1 is impressed on the voltage divider R_5 - R_6 . The values of R_5 and R_6 are in such a ratio that the voltage impressed on the grid of V_2 is $1/A$ times the output voltage of V_1 , where A is the amplification factor of V_1 . The output of V_2 is

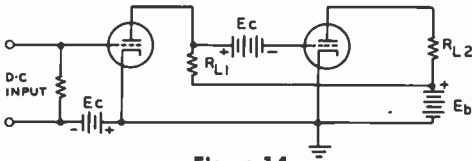

Figure 14

DIRECT-COUPLED D-C AMPLIFIER

then of the same amplitude as the output of V_1 , but of opposite phase.

6-9 D-C Amplifiers

Direct-current amplifiers are special types used where amplification of very slow variations in voltage, or of d-c voltages is desired. A simple d-c amplifier consists of a single tube with a grid resistor across the input terminals, and the load in the plate circuit.

Basic D-C Amplifier Circuit A simple d-c amplifier circuit is shown in figure 14, wherein the grid of one tube is connected directly to the plate of the preceding tube in such a manner that voltage changes on the grid of the first tube will be amplified by the system. The voltage drop across the plate coupling resistor is impressed directly on the grid of the second tube, which is provided with enough negative grid bias to balance out the excessive voltage drop across the coupling resistor. The grid of the second tube is thus maintained in a slightly negative position.

The d-c amplifier will provide good low-frequency response, with negligible phase distortion. High-frequency response is limited by the shunting effect of the tube capacitances, as in the normal resistance-coupled amplifier.

A common fault with d-c amplifiers of all types is static instability. Small changes in the filament, plate, or grid voltages cannot be distinguished from the exciting voltage. Regulated power supplies and special balancing circuits have been devised to reduce the effects of supply variations on these amplifiers. A successful system is to apply the plate potential in phase to two tubes, and to apply the exciting signal to a push-pull grid-circuit configuration. If the two tubes are identical, any change in electrode voltage is

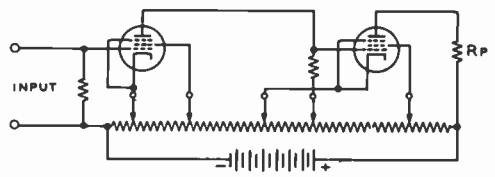

Figure 15

LOFTIN-WHITE D-C AMPLIFIER

balanced out. The use of negative feedback can also greatly reduce drift problems.

The "Loftin-White" Circuit Two d-c amplifier stages may be arranged, so that their plate supplies are effectively in series, as illustrated in figure 15. This is known as a *Loftin-White* amplifier. All plate and grid voltages may be obtained from one master power supply instead of separate grid and plate supplies. A push-pull version of this amplifier (figure 16) can be used to balance out the effects of slow variations in the supply voltage.

6-10 Single-Ended Triode Amplifiers

Figure 17 illustrates five circuits for the operation of class-A triode amplifier stages. Since the cathode current of a triode class-A (no grid current) amplifier stage is constant with and without excitation, it is common practice to operate the tube with cathode bias. Recommended operating conditions in regard to plate voltage, grid bias, and load impedance for conventional triode amplifier stages are given in the RCA Receiving Tube Manuals.

Extended Class-A Operation It is possible, under certain conditions, to operate single-ended triode amplifier stages (and pentode and tetrode stages as well) with grid excitation of sufficient amplitude that grid current is taken by the tube on peaks. This type of operation is called class-A₂ and is characterized by increased plate-circuit efficiency over straight class-A amplification without grid current. The normal class-A amplifier power stage will operate with a plate-circuit efficiency of from 20 percent to perhaps 35 percent.

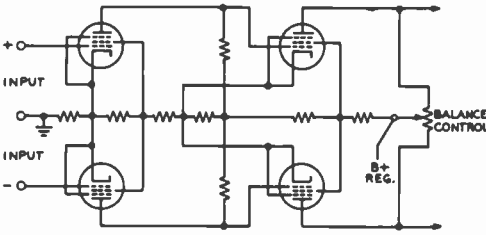

Figure 16

PUSH-PULL D-C AMPLIFIER WITH EITHER SINGLE-ENDED OR PUSH-PULL INPUT

Through the use of class- A_2 operation it is possible to increase this plate-circuit efficiency to approximately 38 to 45 percent. However, such operation requires careful choice of the value of plate load impedance, a grid-bias supply with good regulation (since the tube draws grid current on peaks although the plate current does not change with signal), and a driver tube with moderate power capability to excite the grid of the class A_2 tube.

Figures 17D and 17E illustrate two methods of connection for such stages. Tubes such as the 845, 450TL, and 304TL are suitable for these circuits. In each case the grid bias is approximately the same as would be used for a class-A amplifier using the same tube, and as mentioned before, fixed bias must be used along with an audio driver of good regulation—preferably a triode stage with a 1:1 or step-down driver transformer. In each case it will be found that the correct value of plate load impedance will be increased about 40 percent over the value recommended by the tube manufacturer for class-A operation of the tube.

Operation Characteristics of a Triode Power Amplifier

A class-A power amplifier operates in such a way as to amplify as faithfully as possible the waveform applied to the grid of the tube. Large power output is of more importance than high voltage amplification, consequently gain characteristics may be sacrificed in power-tube design to obtain more important power-handling capabilities. Class-A power tubes, such as the 12BY4A, 2A3, and 6AS7G, are characterized by a low

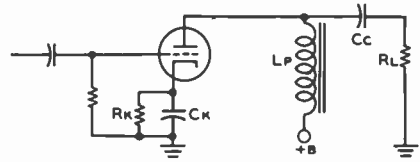

(A) IMPEDANCE COUPLING

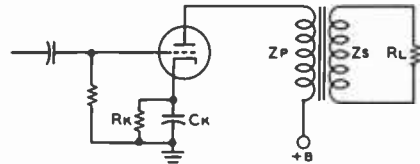

(B) TRANSFORMER COUPLING

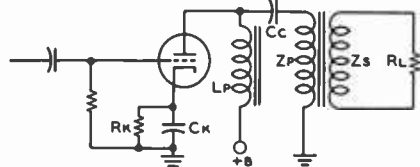

(C) IMPEDANCE-TRANSFORMER COUPLING

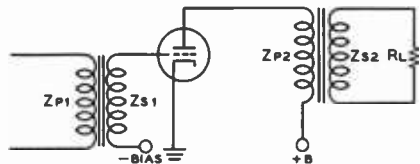

(D) TRANSFORMER COUPLING FOR A_2 OPERATION

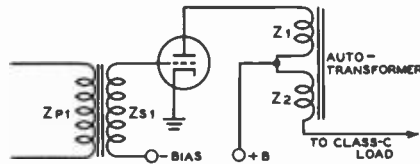

(E) CLASS A_2 MODULATOR WITH AUTOTRANSFORMER COUPLING

Figure 17

Output coupling arrangements for single-ended class-A triode audio-frequency power amplifiers.

amplification factor, high plate dissipation, and relatively high filament emission.

The operating characteristics of a class-A triode amplifier employing an output-transformer coupled load may be calculated from the plate family of curves for the particular tube in question by employing the following steps:

1. The load resistance should be approximately twice the plate resistance of the tube for maximum undistorted

power output. Remember this fact for a quick check on calculations.

- Calculate the zero-signal bias voltage (E_{c1}).

$$E_{c1} = \frac{-(0.68 \times E_b)}{\mu}$$

- Locate the E_{c1} bias point on the I_b versus E_b graph where the E_c bias line crosses the plate-voltage line, as shown in figure 18. Call this point P .
- Locate on the plate family of curves the value of zero-signal plate current, (I_b) corresponding to operating point P .
- Locate $2 \times I_b$ (twice the value of I_b) on the plate-current axis (Y axis). This point corresponds to the value of maximum-signal plate current ($i_{b \max}$).
- Locate point x on the d-c bias curve at zero volts ($E_c = 0$), corresponding to the value of $i_{b \max}$.
- Draw a straight line ($x - y$) through points x and P . This line is the *load-resistance line*. Its slope corresponds to the value of the load resistance.
- Load resistance, (in ohms) equals:

$$R_L = \frac{e_{h \max} - e_{h \min}}{i_{b \max} - i_{b \min}}$$

- Check: Multiply the zero-signal plate current (I_b) by the operating plate voltage, (E_b). If the plate dissipation rating of the tube is exceeded, it is necessary to increase the bias (E_c) on the tube so that the plate dissipation falls within the maximum rating of the tube. If this step is taken, operations 2 through 8 must be repeated with the new value of E_c .
- For maximum power output, the peak a-c grid voltage on the tube should swing to $2E_c$ on the negative cycle, and to zero-bias on the positive cycle. At the peak of the negative swing,

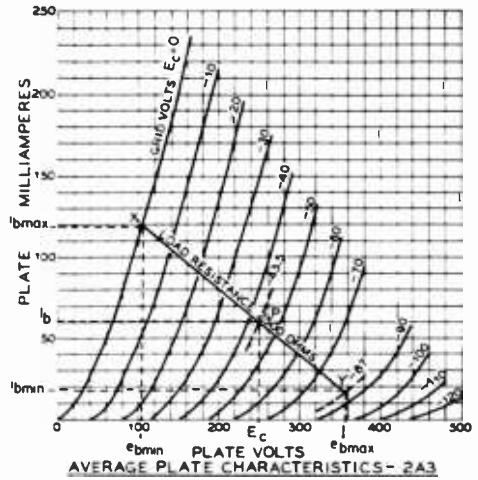

$\mu = 4.2$ $R_p = 800$ OHMS
 PLATE DISSIPATION = 15 WATTS

LOAD RESISTANCE

$$R_L = \frac{e_{b \max} - e_{b \min}}{i_{b \max} - i_{b \min}} \text{ OHMS}$$

POWER OUTPUT

$$P_o = \frac{(i_{b \max} - i_{b \min}) (e_{b \max} - e_{b \min})}{8} \text{ WATTS}$$

SECOND-HARMONIC DISTORTION

$$D_2 = \frac{(i_{b \max} + i_{b \min}) - i_b}{i_{b \max} - i_{b \min}} \times 100 \text{ PERCENT}$$

Figure 18

Formulas for determining the operating conditions of a class-A triode single-ended audio-frequency power output stage. A typical load line has been drawn on the average plate characteristics of a type 2A3 tube to illustrate the procedure.

the plate voltage reaches $e_{h \max}$ and the plate current drops to $i_{b \min}$. On the positive swing of the grid signal, the plate voltage drops to $e_{b \min}$ and the plate current reaches $i_{b \max}$. The power output of the tube in watts is:

$$P_o = \frac{(i_{b \max} - i_{b \min}) \times (e_{h \max} - e_{h \min})}{8}$$

where,

i is in amperes,
 e is in volts.

- The second-harmonic distortion generated in a single-ended class-A triode

amplifier, expressed as a percentage of the fundamental output signal is:

$$\begin{aligned} \% \text{ 2nd harmonic} &= \\ &= \frac{(i_{b \text{ max}} - i_{b \text{ min}})}{2} - I_b \\ &= \frac{i_{b \text{ max}} - i_{b \text{ min}}}{i_{b \text{ max}} - i_{b \text{ min}}} \times 100 \end{aligned}$$

Figure 18 illustrates the above steps as applied to a single class-A 2A3 amplifier stage.

6-11 Single-Ended Pentode Amplifiers

Figure 19 illustrates the conventional circuit for a single-ended tetrode or pentode amplifier stage. Tubes of this type have largely replaced triodes in the output stage of receivers and amplifiers due to the higher plate efficiency (30%—40%) at which they operate. Tetrode and pentode tubes do, however, introduce a considerably greater amount of harmonic distortion in their output circuit, particularly odd harmonics. In addition, their plate-circuit impedance (which acts in an amplifier to damp speaker overshoot and ringing, and acts in a driver stage to provide good regulation) is many times higher than that of an equivalent triode. The application of negative feedback acts both to reduce distortion and to reduce the effective plate-circuit impedance of these tubes.

Operating Characteristics of a Pentode Power Amplifier—The operating characteristics of pentode power amplifiers may be obtained from the plate family of curves, much as in the manner applied to triode tubes. A typical family of pentode plate curves is shown in figure 20.

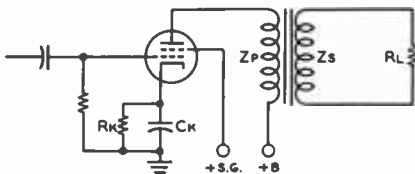

Figure 19

Conventional single-ended pentode or beam tetrode audio-frequency power-output stage.

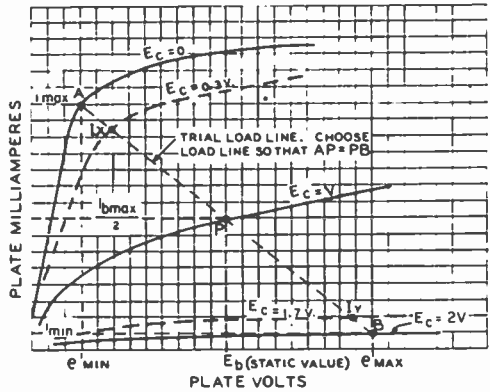

Figure 20

GRAPHIC DETERMINATION OF OPERATING CHARACTERISTICS OF A PENTODE POWER AMPLIFIER

"V" is the negative control grid voltage at the operating point P.

The plate current of the pentode tube is relatively independent of the applied plate voltage, but is sensitive to screen voltage. In general, the correct pentode load resistance is about

$$\frac{0.9 E_b}{I_b}$$

and the power output is somewhat less than

$$\frac{E_b \times I_b}{2}$$

These formulas may be used for a quick check on more precise calculations. To obtain the operating parameters for class-A pentode amplifiers, the following steps are taken:

1. The $i_{b \text{ max}}$ point is chosen so as to fall on the zero-bias curve, just above the "knee" of the curve (point A, figure 20).
2. A preliminary operating point (P) is determined by the intersection of the plate-voltage line (E_b) and the line of $i_{b \text{ max}}/2$. The grid-voltage curve that this point falls on should be one that is about $1/2$ the value of E_c required to cut the plate current to a very low value (point B). Point B represents

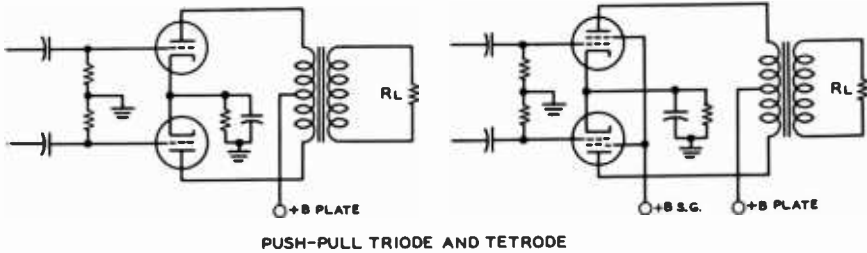

Figure 21
CONVENTIONAL PUSH-PULL CIRCUITS

$i_{b\ min}$ on the plate-current axis (y axis). The line $i_{b\ max}/2$ should be located halfway between $i_{b\ max}$ and $i_{b\ min}$.

3. A trial load line is constructed about point P and point A in such a way that the lengths AP and PB are approximately equal.
4. When the most satisfactory load line has been determined, the load resistance may be calculated:

$$R_L = \frac{e_{h\ max} - e_{h\ min}}{i_{b\ max} - i_{b\ min}}$$

5. The operating bias (E_c) is the bias at point P .
6. The power output is:

$$\frac{(i_{b\ max} - i_{b\ min}) + 1.41 (I_x - I_y)^2 \times R_L}{32}$$

where,

I_x is the plate current at the point on the load line where the grid voltage (e_c) is equal to: $E_c - 0.7 E_c$,

I_y is the plate current at the point where, e_c is equal to: $E_c + 0.7 E_c$.

7. The percentage harmonic distortion is:
% 2nd harmonic distortion =

$$\frac{i_{b\ max} - i_{b\ min} - 2I_{b0}}{i_{b\ max} - i_{b\ min} + 1.41 (I_x - I_y)} \times 100$$

where,

I_{b0} is the static plate current of the tube.

% 3rd harmonic distortion =

$$\frac{i_{b\ max} - i_{b\ min} - 1.41 (I_x - I_y)}{i_{b\ max} - i_{b\ min} + 1.41 (I_x - I_y)} \times 100$$

6-12 Push-Pull Audio Amplifiers

A number of advantages are obtained through the use of the push-pull connection of two or four tubes in an audio-frequency power amplifier. Two conventional circuits for the use of triode and tetrode tubes in the push-pull connection are shown in figure 21. The two main advantages of the push-pull circuit arrangement are: (1) the magnetizing effect of the plate currents of the output tubes is cancelled in the windings of the output transformer; (2) even harmonics of the input signal (second and fourth harmonics primarily) generated in the push-pull stage are cancelled when the tubes are balanced.

The cancellation of even harmonics generated in the stage allows the tubes to be operated class AB—in other words the tubes may be operated with bias and input signals of such amplitude that the plate current of alternate tubes may be cut off during a portion of the input voltage cycle. If a tube were operated in such a manner in a single-ended amplifier the second-harmonic amplitude generated would be prohibitively high.

Push-pull class-AB operation allows a plate circuit efficiency of from 45 to 60 percent to be obtained in an amplifier stage depending on whether or not the exciting voltage is of such amplitude that grid current is drawn by the tubes. If grid current is taken on input voltage peaks the amplifier is said to be operating class-AB₂ and the plate-circuit efficiency can be as high as the upper value just mentioned. If grid current is not taken by the stage it is said to be

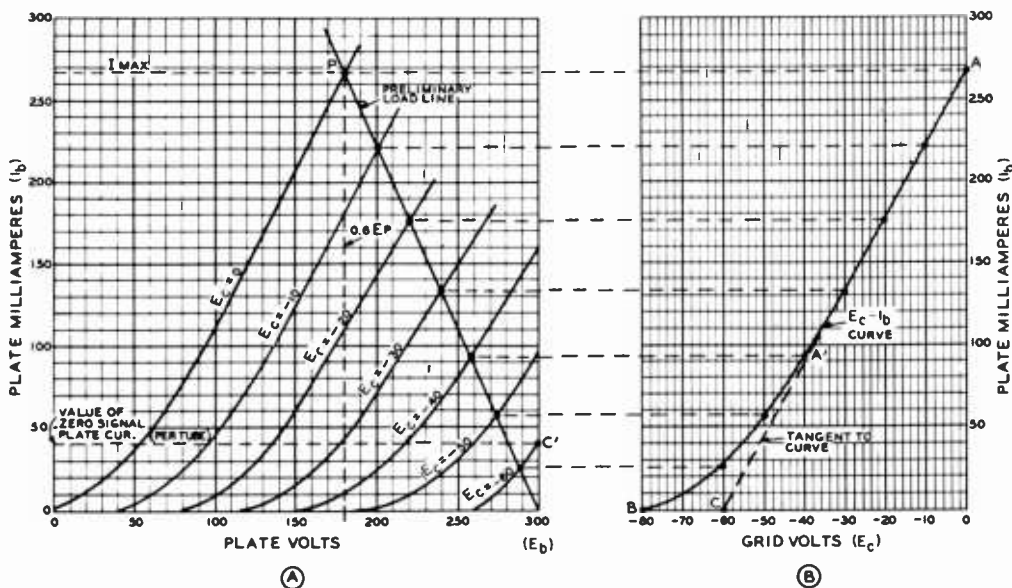

Figure 22

DETERMINATION OF OPERATING PARAMETERS FOR PUSH-PULL CLASS-A TRIODE TUBES

operating class-AB₁ and the plate-circuit efficiency will be toward the lower end of the range just quoted. In all class-AB amplifiers the plate current will increase from 40 to 150 percent over the no-signal value when full excitation voltage is applied.

Operating Characteristics of Push-Pull Class-A Triode Power Amplifier

The operating characteristics of push-pull class-A amplifiers may also be determined from the plate family of curves for a particular triode tube by the following steps:

1. Erect a vertical line from the plate-voltage axis (x-axis) at $0.6 E_b$ (figure 22), which intersects the $E_c = 0$ curve. This point of intersection (P), interpolated to the plate current axis (y-axis), may be taken as $i_{b \text{ max}}$. It is assumed for simplification that $i_{b \text{ max}}$ occurs at the point of the zero-bias curve corresponding to $0.6 E_b$.
2. The power output obtainable from the two tubes is:

$$(P_o) = \frac{i_{b \text{ max}}}{5}$$

where,

- P_o is expressed in watts,
- $i_{b \text{ max}}$ is in amperes,
- E_b is the applied plate voltage.

3. Draw a preliminary load line through point P to the E_b point located on the x-axis (the zero plate-current line). This load line represents $1/4$ of the actual plate-to-plate load of the class-A tubes. Therefore:

$$R_L (\text{plate-to-plate}) = 4 \times \frac{E_b - 0.6 E_b}{i_{b \text{ max}}} = \frac{1.6 E_b}{i_{b \text{ max}}}$$

Figure 22 illustrates the above steps applied to a push-pull class-A amplifier using two 2A3 tubes.

4. The average plate current is $0.636 i_{b \text{ max}}$, and multiplied by plate voltage E_b , will give the average watts input to the plates of the two tubes. The power output should be subtracted

from this value to obtain the total operating plate dissipation of the two tubes. If the plate dissipation is excessive, a slightly higher value of R_L should be chosen to limit the plate dissipation.

5. The correct value of operating bias, and the static plate current for the push-pull tubes may be determined from the E_c versus I_b curves, which are a derivation of the E_b versus I_b curves for various values of E_c .
6. The E_c versus I_b curve may be constructed in this manner: Values of grid bias are read from the intersection of each grid-bias curve with the load line. These points are transferred to the E_c versus I_b graph to produce a curved line, $A-B$. If the grid bias curves of the E_b versus I_c graph were straight lines, the lines of the E_c versus I_b graph would also be straight. This is usually not the case. A tangent to this curve is therefore drawn, starting at point A' , and intersecting the grid-voltage abscissa (x -axis). This intersection (C) is the operating-bias point for fixed-bias operation.
7. This operating-bias point may now be plotted on the original E_c versus I_b family of curves (C'), and the zero-signal current produced by this bias is determined. This operating bias point (C') does not fall on the operating load line, as in the case of a single-ended amplifier.
8. Under conditions of maximum power output, the exciting signal voltage swings from zero-bias voltage to zero-bias voltage for each of the tubes on each half of the signal cycle. Second-harmonic distortion is largely cancelled out.

6-13 Class-B Audio-Frequency Power Amplifiers

The class-B audio-frequency power amplifier (figure 23) operates at a higher plate-circuit efficiency than any of the previously described types of audio power amplifiers. Full-signal plate-circuit efficiencies of 60 to

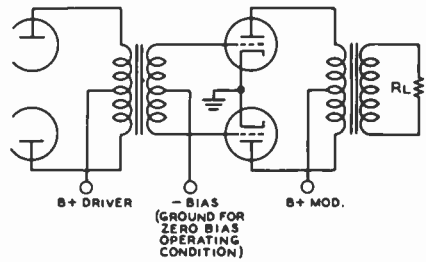

Figure 23

CLASS-B AUDIO-FREQUENCY POWER AMPLIFIER

70 percent are readily obtainable with the tube types presently available for this mode of operation. Since the plate-circuit efficiency is higher, smaller tubes of lower plate dissipation may be used in a class-B power amplifier of a given power output than can be used in any other conventional type of audio amplifier. An additional factor in favor of the class-B audio amplifier is the fact that the power input to the stage is relatively low under no-signal conditions. It is for these reasons that this type of amplifier has largely superseded other types for the generation of audio-frequency levels from perhaps 100 watts on up to levels of approximately 150,000 watts as required for large short-wave broadcast stations.

Disadvantages of Class-B Amplifier Operation There are attendant disadvantages to the operation of a power amplifier of this type; but all these disadvantages can be overcome by proper design of the circuits associated with the power-amplifier stage. These disadvantages are: (1) The class-B audio amplifier requires driving power in its grid circuit; this requirement can be overcome by the use of an oversize power stage preceding the class-B stage with a step-down transformer between the driver stage and the class-B grids. Degenerative feedback is sometimes employed to reduce the plate impedance of the driver stage and thus to improve the voltage regulation under the varying load presented by the class-B grids. (2) The class-B stage requires a constant value of average grid bias to be supplied in spite of

the fact that the grid current of the stage is zero over most of the cycle but rises to value as high as one-third of the peak plate current at the peak of the exciting voltage cycle. Special regulated bias supplies have been used for this application, or B batteries can be used. However, a number of tubes especially designed for class-B audio amplifiers have been developed which require zero average grid bias for their operation. The 811A, 805, 3-400Z, and 3-1000Z are examples of this type of tube. All these so-called *zero-bias* tubes have rated operating conditions up to moderate plate voltages wherein they can be operated without grid bias. As the plate voltage is increased to the maximum ratings, however, a small amount of grid bias, such as could be obtained from a regulated bias supply, is required. (3) A class-B audio-frequency power amplifier or modulator requires a source of plate-supply voltage having reasonably good regulation. This requirement led to the development of the *swinging choke*. The swinging choke is essentially a conventional filter choke in which the core air gap has been reduced. This reduction in the air gap allows the choke to have a much greater value of inductance with low-current values such as are encountered with no signal or small signal being applied to the class-B stage.

With a higher value of current such as would be taken by a class-B stage with full signal applied, the inductance of the choke drops to a much lower value. With a swinging choke of this type, having adequate current rating, as the input inductor in the filter system for a rectifier power supply, the regulation will be improved to a point which is normally adequate for a power supply for a class-B amplifier or modulator stage.

Calculation of Operating Conditions of Class-B Power Amplifiers The following procedure can be used for the calculation of the operating conditions of class-B power amplifiers when they are to operate into a resistive load such as presented by a class-C power amplifier. This procedure will be found quite satisfactory for the application of vacuum tubes as class-B modulators when it is desired to operate the tubes under conditions which are

not specified in the tube operating characteristics published by the tube manufacturer. The same procedure can be used with equal effectiveness for the calculation of the operating conditions of beam tetrodes as class-AB₂ amplifiers or modulators when the resting plate current of the tubes (no-signal condition) is less than 25 or 30 percent of the maximum-signal plate current.

1. With the average plate characteristics of the tube as published by the manufacturer before you, select a point on the $E_b = E_c$ (diode bend) line at about twice the plate current you expect the tubes to draw under modulation peaks. If beam tetrode tubes are concerned, select a point at about the same amount of plate current mentioned above, just to the right of the region where the I_b line takes a sharp curve downward. This will be the first trial point, and the plate voltage at the point chosen should be not more than about 20 percent of the d-c voltage applied to the tubes if good plate-circuit efficiency is desired.
2. Note down the value of $i_{b\ max}$ and $e_{h\ min}$ at this point.
3. Subtract the value of $e_{h\ min}$ from the d-c plate voltage on the tubes.
4. Substitute the values obtained in the following equations:

$$P_o (2\ tubes) = \frac{i_{b\ max} (E_b - e_{h\ min})}{2}$$

$$R_{L_t} (2\ tubes) = 4 \frac{(E_b - e_{h\ min})}{i_{b\ max}}$$

$$\text{Full signal efficiency } (N_p) =$$

$$78.5 \left(1 - \frac{e_{h\ min}}{E_b} \right)$$

Effects of Speech Clipping All the above equations are true for sine-wave operating condition of the tubes concerned. However, if a speech clipper is being used in the speech amplifier, or if it is desired to calculate the operating conditions on the basis of the fact that the ratio of peak power to average power in a speech wave is approximately 4 to 1 as contrasted to the ratio of 2 to 1 in a sine wave — in

other words, when nonsinusoidal waves such as plain speech or speech that has passed through a clipper are concerned, we are no longer concerned with average power output of the modulator as far as its capability of modulating a class-C amplifier is concerned; we are concerned with its *peak power output* capability.

Under these conditions we call on other, more general relationships. The first of these is: it requires a *peak* power output *equal* to the class-C stage input to modulate that input fully.

The second relationship is: the average power output required of the modulator is equal to the shape factor of the modulating wave multiplied by the input to the class-C stage. The shape factor of unclipped speech is approximately 0.25. The shape factor of a sine wave is 0.5. The shape factor of a speech wave that has been passed through a clipper-filter arrangement is somewhere between 0.25 and 0.9 depending on the amount of clipping that has taken place. With 15 or 20 db of clipping the shape factor may be as high as the figure of 0.9 mentioned above. This means that the audio power output of the modulator will be 90% of the input to the class-C stage. Thus with a kilowatt input we would be putting 900 watts of audio into the class-C stage for 100 percent modulation as contrasted to perhaps 250 watts for unclipped speech modulation of 100 percent.

Sample Calculation for 811A Tubes Figure 24 shows a set of plate characteristics for a type 811A tube with a load line for class-B operation. Figure 25 lists a sample calculation for determining the proper operating conditions for obtaining approximately 185 watts output from a pair of the tubes with 1000 volts d-c plate potential. Also shown in figure 25 is the method of determining the proper ratio for the modulation transformer to couple between the 811's or 811A's and the anticipated final amplifier which is to operate at 2000 plate volts and 175 ma plate current.

Modulation Transformer Calculation The method illustrated in figure 25 can be used in general for the determination of the proper transformer ratio to couple between the modula-

tor tube and the amplifier to be modulated. The procedure can be stated as follows: (1) Determine the proper plate-to-plate load impedance for the modulator tubes either by the use of the type of calculation shown in figure 25, or by reference to the published characteristics on the tubes to be used. (2) Determine the load impedance which will be presented by the class-C amplifier stage to be modulated by dividing the operating plate voltage on that stage by the operating value of plate current in *amperes*. (3) Divide the class-C load impedance determined in (2) above by the plate-to-plate load impedance for the modulator tubes determined in (1) above. The ratio determined in this way is the secondary-to-primary *impedance* ratio. (4) Take the square root of this ratio to determine the secondary-to-primary *turns* ratio. If the turns ratio is greater than unity, the use of a step-up transformer is required. If the turns ratio as determined in this way is less than unity, a step-down transformer is called for.

If the procedure shown in figure 25 has been used to calculate the operating conditions for the modulator tubes, the transformer ratio calculation can be checked in the following manner: Divide the plate voltage on the modulated amplifier by the total voltage swing on the modulator tubes ($2 \times [E_b - e_{b\ min}]$). This ratio should be quite close numerically to the transformer turns ratio as previously determined. The reason for this condition is that the ratio between the total primary voltage and the d-c plate-supply voltage on the modulated stage is equal to the turns ratio of the transformer, since a peak secondary voltage equal to the plate voltage on the modulated stage is required to modulate this stage 100 percent.

Use of Clipper Speech Amplifier with Tetrode Modulator Tubes When a clipper speech amplifier is used in conjunction with a class-B modulator stage, the plate current on that stage will rise to a higher value with modulation (due to the greater average power output and input) but the plate dissipation on the tubes will ordinarily be less than with sine-wave modulation. However, when tetrode tubes are used as modulators, the screen dissipation will be much greater than with sine-wave

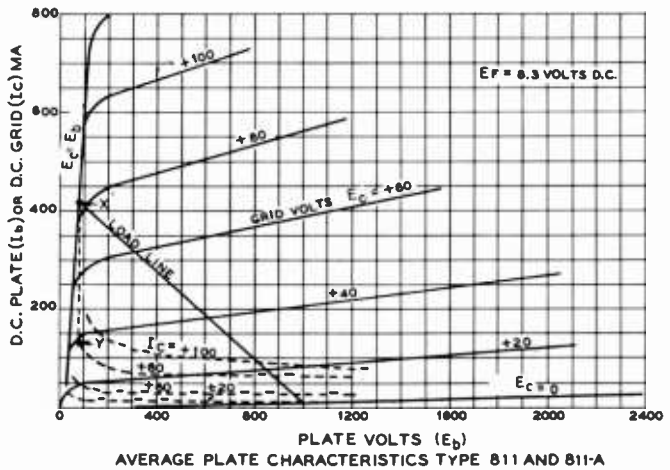

Figure 24

Typical class-B a-f amplifier load line. The load line has been drawn on the average characteristics of a type 811 tube.

modulation. Care must be taken to ensure that the screen dissipation rating on the modulator tubes is not exceeded under full modulation conditions with a clipper speech amplifier. The screen dissipation is equal to screen voltage times screen current.

Practical Aspects of Class-B Modulators As stated previously, a class-B audio amplifier requires the driving stage to supply well-regulated audio power to the grid circuit of the class-B stage. Since the performance of a class-B modulator may easily be impaired by an improperly designed driver stage, it is well to study the problems incurred in the design of the driver stage.

SAMPLE CALCULATION

CONDITION: 2 TYPE 811 TUBES, $E_b = 1000$
 INPUT TO FINAL STAGE, 350 W.
 PEAK POWER OUTPUT NEEDED = $350 + 8\% = 370$ W
 FINAL AMPLIFIER $E_b = 2000$ V.
 FINAL AMPLIFIER $I_b = .175$ A.
 FINAL AMPLIFIER ZL = $\frac{2000}{.175} = 11400 \Omega$

EXAMPLE: CHOSE POINT ON 811 CHARACTERISTICS JUST TO RIGHT OF $E_b = E_c$ (POINT X, FIG. 24)
 $I_{bmax} = .410$ A. $E_{bmin} = +100$
 $I_{cmax} = .100$ A. $E_{cmin} = +80$

PEAK $P_o = .410 \times (1000 - 100) = .410 \times 900 = 369$ W.
 $R_L = 4 \times \frac{350}{.410} = 8800 \Omega$
 $\eta_p = 78.5 \left(1 - \frac{100}{1000}\right) = 78.5 (.9) = 70.5\%$
 W_o (AVERAGE WITH SINE WAVE) = $\frac{P_o(\text{PEAK})}{2} = 184.5$ W
 $W_{in} = \frac{184.5}{70.5} = 260$ W.
 I_b (MAXIMUM WITH SINE WAVE) = 280 MA
 $W_G \text{ PEAK} = .100 \times 80 = 8$ W.
 DRIVING POWER = $\frac{W_G \text{ PEAK}}{2} = 4$ W.

TRANSFORMER:
 $\frac{Z_s}{Z_p} = \frac{11400}{8800} = 1.29$
 TURNS RATIO = $\sqrt{\frac{Z_s}{Z_p}} = \sqrt{1.29} = 1.14$ STEP UP

Figure 25

Typical calculation of operating conditions for a class-B a-f power amplifier using a pair of type 811 or 811A tubes. Plate characteristics and load line are shown in figure 24.

The grid circuit of a class-B modulator may be compared to a variable resistance which decreases in value as the exciting grid voltage is increased. This variable resistance appears across the secondary terminals of the driver transformer so that the driver stage is called on to deliver power to a varying load. For best operation of the class-B stage, the grid excitation voltage should not drop as the power taken by the grid circuit increases. These opposing conditions call for a high order of voltage regulation in the driver-stage plate circuit. In order to enhance the voltage regulation of this circuit, the driver tubes must have low plate resistance, the driver transformer must have as large a step-down ratio as possible, and the d-c resistance of both primary and secondary windings of the driver transformer should be low.

The driver transformer should reflect into the plate circuit of the driver tubes a load of such value that the required driving power is just developed with full excitation applied to the driver grid circuit. If this is done, the driver transformer will have as high a step-down ratio as is consistent with

the maximum drive requirements of the class-B stage. If the step-down ratio of the driver transformer is too large, the driver plate load will be so high that the power required to drive the class-B stage to full output cannot be developed. If the step-down ratio is too small the regulation of the driver stage will be impaired.

Driver-Stage Calculations The parameters for the driver stage may be calculated from the plate characteristic curve, a sample of which is shown in figure 24. The required positive grid voltage ($e_{c \text{ max}}$) for the 811A tubes used in the sample calculation is found at point X, the intersection of the load line and the peak plate current as found on the y-axis. This is +80 volts. If a vertical line is dropped from point X to intersect the dotted grid-current curves, it will be found that the grid current for a single 811A at this value of grid voltage is 100 milliamperes (point Y). The peak grid-driving power is therefore $80 \times 0.100 = 8$ watts. The approximate *average* driving power is 4 watts. This is an approximate figure because the grid impedance is not constant over the entire audio cycle.

A pair of 2A3 tubes will be used as drivers, operating class-A, with the maximum excitation to the drivers occurring just below the point of grid-current flow in the 2A3 tubes. The driver plate voltage is 300 volts, and the grid bias is -62 volts. The peak power (P_p) developed in the primary winding of the driver transformer is:

$$(P_p) = 2R_L \left(\frac{\mu e_{c \text{ max}}}{R_p + R_L} \right)^2$$

where,

μ is the amplification factor of the driver tubes (4.2 for 2A3),

e_c is the peak grid swing of the driver stage (62 volts),

R_p is the plate resistance of one driver tube (800 ohms),

R_L is $\frac{1}{2}$ the plate-to-plate load of the driver stage,

P_p (peak power in watts) is 8 watts.

Solving the above equation for R_L , we obtain a value of 14,500 ohms load, plate to plate for the 2A3 driver tubes.

The peak primary voltage (e_{pri}) is then found from the formula:

$$e_{pri} = 2R_L \times \frac{\mu e_{c \text{ max}}}{R_p + R_L} = 493 \text{ volts}$$

and the turns ratio of the driver transformer (primary to $\frac{1}{2}$ secondary) is:

$$\frac{e_{pri}}{e_{c \text{ max}}} = \frac{493}{80} = 6.15:1$$

Plate Circuit Impedance Matching One of the most common causes of distortion in a class-B modulator is incorrect load impedance in the plate circuit. The purpose of the class-B modulation transformer is to take the power developed by the modulator (which has a certain operating impedance) and transform it to the operating impedance imposed by the modulated amplifier stage.

If the transformer in question has the same number of turns on the primary winding as it has on the secondary winding, the turns ratio is 1:1, and the impedance ratio is also 1:1. If a 10,000-ohm resistor is placed across the secondary terminals of the transformer, a *reflected load* of 10,000 ohms would appear across the primary terminals. If the resistor is changed to one of 2376 ohms, the reflected primary impedance would also be 2376 ohms.

If the transformer has twice as many turns on the secondary as on the primary, the turns ratio is 2:1. The impedance ratio is the square of the turns ratio, or 4:1. If a 10,000-ohm resistor is now placed across the secondary winding, a reflected load of 2500 ohms will appear across the primary winding.

Effects of Plate Circuit Mismatch It can be seen from the above paragraphs that the class-B modulator plate load is entirely dependent on the load placed on the secondary terminals of the class-B modulation transformer. If the secondary load is incorrect, certain changes will take place in the operation of the class-B modulator stage.

When the modulator load impedance is too low, the efficiency of the class-B stage is reduced and the plate dissipation of the tubes is increased. Peak plate current of the modulator stage is increased, and saturation of the modulation transformer core may result. "Talk-back" of the modulation trans-

former may result if the plate load impedance of the modulator stage is too low.

When the modulator load impedance is too high, the maximum power capability of the stage is reduced. An attempt to increase the output by increasing grid excitation to the stage will result in peak clipping of the audio wave. In addition, high peak voltages may be built up in the plate circuit that may damage the modulation transformer.

6-14 Cathode-Follower Power Amplifiers

The *cathode follower* is essentially a power output stage in which the exciting signal is applied between grid and ground. The plate is maintained at ground potential with respect to input and output signals, and the output signal is taken between cathode and ground.

Types of Cathode-Follower Amplifiers Figure 26 illustrates four types of cathode-follower power amplifiers in common usage and figure 27 shows the output impedance (R_{T_1}), and stage gain (A) of both triode and pentode (or tetrode) cathode-follower stages. It will be seen by inspection of the equations that the stage voltage gain is always less than unity, and that the output impedance of the stage is much less than the same stage operated as a conventional cathode-return amplifier. The output impedance for conventional tubes will be somewhere between 100 and 1000 ohms, depending primarily on the transconductance of the tube.

This reduction in gain and output impedance for the cathode follower comes about since the stage operates as though it has 100 percent degenerative feedback applied between its output and input circuit. Even though the voltage gain of the stage is reduced to a value less than unity by the action of the degenerative feedback, the power gain of the stage (if it is operating class-A) is not reduced. Although more voltage is required to excite a cathode-follower amplifier than appears across the load circuit (since the cathode "follows" along with the grid) the relative grid-to-cathode voltage is essentially the same as in a conventional amplifier.

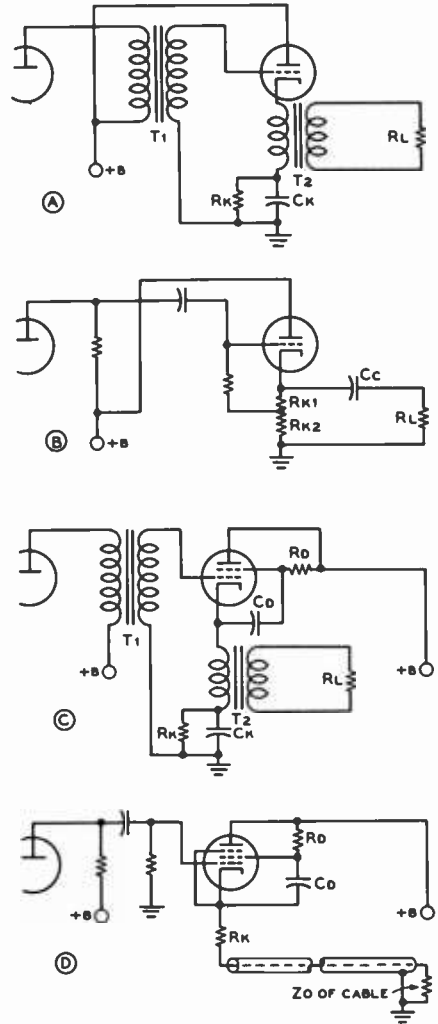

Figure 26
CATHODE-FOLLOWER OUTPUT
CIRCUITS FOR AUDIO OR
VIDEO AMPLIFIERS

Use of Cathode-Follower Amplifiers Although the cathode follower gives no voltage gain, it is an effective power amplifier where it is desired to feed a low-impedance load, or where it is desired to feed a load of varying impedance with a signal having good regulation. This latter capability makes the cathode follower particularly effective as a driver for the grids of a class-B modulator stage.

TRIODE:
$$\mu_{CF} = \frac{\mu}{\mu + 1}$$

$$A = \frac{\mu R_L}{R_L(\mu + 1) + R_p}$$

$$R_{O(CATHODE)} = \frac{R_p}{\mu + 1}$$

$$R_L = \frac{(R_{K1} + R_{K2}) R_L'}{R_{K1} + R_{K2} + R_L'}$$

PENTODE:
$$R_{O(CATHODE)} = \frac{1}{G_m}$$

$$R_{eq} = \frac{R_L}{1 + R_L G_m}$$

$$A = G_m R_{eq}$$

Figure 27

Equivalent factors for pentode (or tetrode) cathode-follower power amplifiers

The circuit of figure 26A is the type of amplifier, either single-ended or push-pull, which may be used as a driver for a class-B modulator or which may be used for other applications such as feeding a speaker where unusually good damping of the speaker is desired. If the d-c resistance of the primary of the transformer (T_2) is approximately the correct value for the cathode bias resistor for the amplifier tube, the components R_k and C_k need not be used. Figure 26B shows an arrangement which may be used to feed directly a value of load impedance which is equal to or higher than the cathode impedance of the amplifier tube. The value of C_c must be quite high, somewhat higher than would be used in a conventional circuit, if the frequency response of the circuit when operating into a low-impedance load is to be preserved.

Figures 26C and 26D show cathode-follower circuits for use with tetrode or pentode tubes. Figure 26C is a circuit similar to that shown in 26A and essentially the same comments apply in regard to components R_k and C_k and the primary resistance of transformer T_2 . Notice also that the screen of the tube is maintained at the same signal potential as the cathode by means of coupling capacitor C_d . This capacitance should be large enough so that at the lowest frequency it is desired to pass through the stage, its reactance will be low with respect to the dynamic screen-to-cathode resistance in parallel with R_d . T_2 in this stage as well as in the circuit of figure 26A should have the proper turns (or impedance) ratio to give the desired step-down or step-up from the cathode circuit to the load. Figure 26D is an arrangement frequently used in video

systems for feeding a coaxial cable of relatively low impedance from a vacuum-tube amplifier. A pentode or tetrode tube with a cathode impedance as a cathode follower ($1/G_m$) of approximately the same impedance as the cable should be chosen. The 12BY7A and 6CL6 have cathode impedances of the same order as the surge impedances of certain types of low-capacitance coaxial cable. An arrangement such as 26D is also usable for feeding coaxial cable with audio or r-f energy where it is desired to transmit the output signal over moderate distances. The resistor R_k is added to the circuit as shown if the cathode impedance of the tube used is lower than the characteristic impedance of the cable. If the output impedance of the stage is higher than the cable impedance, a resistance of appropriate value is sometimes placed in parallel with the input end of the cable. The values of C_d and R_d should be chosen with the same considerations in mind as mentioned in the discussion of the circuit of figure 26C.

The Cathode Follower in R-F Stages

The cathode follower may conveniently be used as a method of coupling r-f or i-f energy between two units separated a considerable distance. In such an application a coaxial cable should be used to carry the r-f or i-f energy. One such application would be for carrying the output of a vfo to a transmitter located a considerable distance from the operating position. Another application would be where it is desired to feed a single-sideband demodulator, an f-m adaptor, or another accessory with an intermediate-frequency signal from a communications receiver. A tube such as a 6CB6 connected in a manner such as is shown in figure 26D would be adequate for the i-f amplifier coupler, while a 6AQ5 or a 6CL6 could be used in the output stage of a vfo as a cathode follower to feed the coaxial line which carries the vfo signal from the control unit to the transmitter proper.

6-15 Feedback Amplifiers

It is possible to modify the characteristics of an amplifier by feeding back a portion of the output to the input. All components, circuits, and tubes included between the

point where the feedback is taken off and the point where the feedback energy is inserted are said to be included within the feedback loop. An amplifier containing a feedback loop is said to be a *feedback amplifier*. One stage or any number of stages may be included within the feedback loop. However, the difficulty of obtaining proper operation of a feedback amplifier increases with the bandwidth of the amplifier, and with the number of stages and circuit elements included within the feedback loop.

Gain and Phase Shift in Feedback Amplifiers The gain and phase shift of any amplifier are functions of frequency. For any amplifier containing a feedback loop to be completely stable, the gain of such an amplifier, as measured from the input back to the point where the feedback circuit connects to the input, must be less than unity at the frequency where the feedback voltage is in phase with the input voltage of the amplifier. If the gain is equal to or more than unity at the frequency where the feedback voltage is in phase with the input, the amplifier will oscillate. This fact imposes a limitation on the amount of feedback which may be employed in an amplifier which is to remain stable. If the reader is

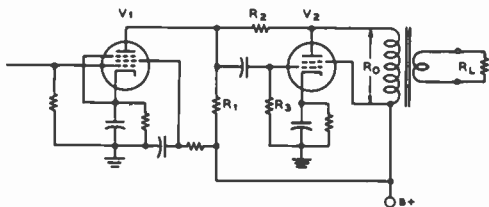

$$\text{DB FEEDBACK} = 20 \text{ LOG} \left[\frac{R_2 + R_A (G_{mV2} R_0)}{R_2} \right]$$

$$= 20 \text{ LOG} \left[\frac{R_2 + R_A (\text{VOLTAGE GAIN OF } V_2)}{R_2} \right]$$

$$\text{GAIN OF BOTH STAGES} = \left[G_{mV1} \left(\frac{R_B \times R_A}{R_B + R_A} \right) \right] \times (G_{mV2} R_0)$$

WHERE:

$$R_A = \frac{R_1 \times R_3}{R_1 + R_3}$$

$$R_B = \frac{R_2}{G_{mV2} R_0}$$

R_0 = REFLECTED LOAD IMPEDANCE ON V_2

R_2 = FEEDBACK RESISTOR (USUALLY ABOUT 300 K)

$$\text{OUTPUT IMPEDANCE} = \frac{R_N R_2}{\left[R_2 + R_A (G_{mV2} R_0) \right] \times \left(1 + \frac{R_N}{R_0} \right)}$$

R_N = PLATE IMPEDANCE OF V_2

Figure 29

SHUNT FEEDBACK CIRCUIT FOR PENTODES OR TETRODES

This circuit requires only the addition of one resistor (R_2) to the normal circuit for such an application. The plate impedance and distortion introduced by the output stage are materially reduced.

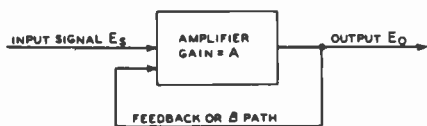

VOLTAGE AMPLIFICATION WITH FEEDBACK = $\frac{A}{1 - A \beta}$

A = GAIN IN ABSENCE OF FEEDBACK

β = FRACTION OF OUTPUT VOLTAGE FED BACK

β IS NEGATIVE FOR NEGATIVE FEEDBACK

FEEDBACK IN DECIBELS = $20 \text{ LOG} (1 - A \beta)$

= $20 \text{ LOG} \frac{\text{MID-FREQ. GAIN WITHOUT FEEDBACK}}{\text{MID-FREQ. GAIN WITH FEEDBACK}}$

DISTORTION WITH FEEDBACK = $\frac{\text{DISTORTION WITHOUT FEEDBACK}}{(1 - A \beta)}$

$$R_0 = \frac{R_N}{1 - A \beta \left(1 + \frac{R_N}{R_L} \right)}$$

WHERE:

R_0 = OUTPUT IMPEDANCE OF AMPLIFIER WITH FEEDBACK

R_N = OUTPUT IMPEDANCE OF AMPLIFIER WITHOUT FEEDBACK

R_L = LOAD IMPEDANCE INTO WHICH AMPLIFIER OPERATES

Figure 28

FEEDBACK AMPLIFIER RELATIONSHIPS

desirous of designing amplifiers in which a large amount of feedback is to be employed he is referred to a book on the subject by H. W. Bode.*

Types of Feedback Feedback may be either negative or positive, and the feedback voltage may be proportional either to output voltage or output current. The most commonly used type of feedback with a-f or video amplifiers is *negative feedback* proportional to output voltage. Figure 28 gives the general operating conditions for feedback amplifiers. Note that the reduction in distortion is proportional to the reduction in gain of the amplifier, and also that the reduction in the output impedance of the amplifier is somewhat greater than the reduction in the gain by an amount which is a function of the ratio of the output impedance of the

* H. W. Bode, *Network Analysis and Feedback Amplifier Design*. D. Van Nostrand Company, Inc. Princeton, New Jersey.

amplifier without feedback to the load impedance. The reduction in noise and hum in those stages included within the feedback loop is proportional to the reduction in gain. However, due to the reduction in gain of the output section of the amplifier somewhat increased gain is required of the stages preceding the stages included within the feedback loop. Therefore the noise and hum output of the entire amplifier may or may not be reduced dependent on the relative contributions of the first part and the latter part of the amplifier to hum and noise. If most of the noise and hum is coming from the stages included within the feedback loop the undesired signals will be reduced in the output from the complete amplifier. It is most frequently true in conventional ampli-

fiers that the hum and distortion come from the latter stages, hence these will be reduced by feedback, but thermal agitation and microphonic noise come from the first stage and will not be reduced but may be increased by feedback unless the feedback loop includes the first stage of the amplifier.

Figure 29 illustrates a very simple and effective application of negative-voltage feedback to an output pentode or tetrode amplifier stage. The reduction in hum and distortion may amount to 15 to 20 db. The reduction in the effective plate impedance of the stage will be by a factor of 20 to 100 depending on the operating conditions. The circuit is commonly used in commercial equipment with tubes such as the 6AU6 for V_1 and the 6AQ5 for V_2 .

Radio-Frequency Power Amplifiers

All modern radio transmitters consist of a comparatively low-level source of radio-frequency energy which is amplified in strength and mixed or multiplied in frequency to achieve the desired power level and operating frequency. Microwave transmitters may be of the self-excited oscillator type, but when it is possible to use r-f amplifiers in uhf transmitters the flexibility of their application is increased.

Radio-frequency power amplifiers are generally classified according to frequency range (hf, vhf, uhf, etc.), power level, type of tube used, and type of service (a-m, f-m, c-w, SSB). In addition, the amplifier may be classified according to mode, or dynamic operating characteristic of the tube (Class AB₁, B, or C); and according to circuitry (grid driven or cathode driven). Each mode of operation and circuit configuration has its distinct advantages and disadvantages, and no one mode or circuit is superior in all respects to any other. As a result, modern transmitting equipments employ various modes of operation, intermixed with various tubes and circuit configurations. The following portion of this chapter will be devoted to the calculation of dynamic characteristics for some of the more practical modes of tuned power amplifier operation.

7-1 Class-C R-F Power Amplifiers

It is often desired to operate the r-f power amplifier in the class-B or class-C mode since such stages can be made to give high

plate-circuit efficiency. Hence, the tube cost and cost of power to supply the stage is least for any given power output. Nevertheless, the class-C amplifier provides less *power gain* than either a class-A or class-B amplifier under similar conditions. The grid of the class-C amplifier must be driven highly positive over the small portion of the exciting signal when the instantaneous plate voltage on the tube is at its lower point, and is at a large negative potential over a major portion of the operating cycle. As a result, no plate current will flow except during the time plate voltage is very low. Comparatively large amounts of drive power are necessary to achieve this mode of operation. Class-C operational efficiency is high because no plate current flows except when the plate-to-cathode voltage drop across the tube is at its lowest value, but the price paid for stage efficiency is the large value of drive power required to achieve this mode of operation.

The gain of a class-B amplifier is higher than that of the class-C stage, and driving power is less in comparison. In addition, the class-B amplifier may be considered to be linear; that is, the output voltage is a replica of the input voltage at all signal levels up to overload. This is not true in the case of the class-C amplifier whose output waveform consist of short pulses of current, as discussed later in this chapter.

The gain of a class-A amplifier is higher than that of the class-B or class-C stage, but the efficiency is the lowest of the three modes of operation. As with the class-B

stage, the class-A amplifier is considered to be linear with respect to input and output waveforms.

Relationships in Class-C Stage The class-C amplifier is analyzed as its operation provides an all-inclusive case of the study of class-B and class-AB₁ r-f amplifiers.

The class-C amplifier is characterized by the fact that the plate current flows in pulses which, by definition, are less than one-half of the operating cycle. The operating cycle is that portion of the electrical cycle in which the grid is driven in a positive direction with respect to the cathode. The operating cycle is considered in terms of the plate or grid conduction angle (θ). The conduction angle is an expression of that fraction of time (expressed in degrees of the electrical cycle) that the tube conducts plate or grid current as compared to the operating cycle of the input voltage waveform.

The theoretical efficiency of any power amplifier depends on the magnitude of the conduction angle; a tuned class-A amplifier having a large conduction angle with a maximum theoretical efficiency of 50 percent; a class-B amplifier with an angle of 180 degrees, and efficiency of 78.5 percent; and a class-C amplifier with an angle of about 160 degrees and efficiency of about 85 percent.

Figure 1 illustrates a transfer curve representing the relationships between grid and plate voltages and currents during the operating cycle of a class-C amplifier. Symbols shown in figure 1 and given in the following discussion are defined and listed in the *Glossary of Terms* included at the front of this Handbook.

The plot is of the transfer curve of a typical triode tube, and represents the change in plate current, (i_b) for a given amount of grid voltage (e_c). The representation is of the form of the I_b versus E_c plot for a triode shown in figure 9, chapter 4.

The operating point, or grid-bias level (E_c), is chosen at several times cutoff bias (E_{c0}), and superimposed on the operating point is one-half cycle of the grid exciting voltage, $e_{c \text{ max}}$. A sample point of grid voltage, e_{cx} , is shown to produce a value of

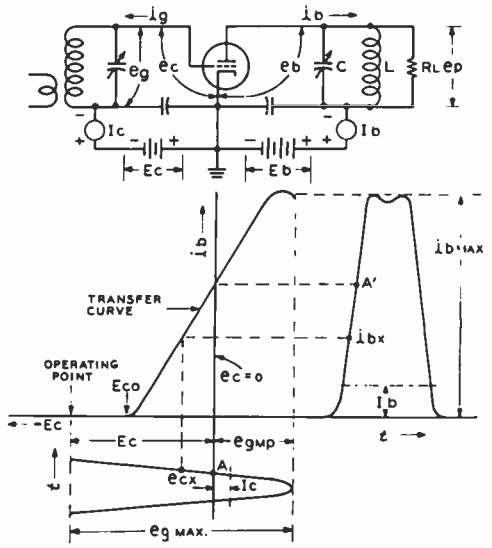

Figure 1
TRANSFER CURVE FOR OPERATING CYCLE OF CLASS-C AMPLIFIER

Typical class-C amplifier (less neutralizing circuits) is shown with various average and instantaneous voltages noted. A summary of symbols is given in the glossary of terms. The plot is of the transfer curve, representing the change in plate current for a given grid voltage. The grid signal ($e_{g \text{ max}}$) is represented by a pulse of voltage along the y-axis, with the operating point determined by the amount of grid bias, E_c . As the waveform rises in amplitude, a corresponding pulse of plate current is developed across the plate load impedance, (R_L). A single point of grid voltage (A) represents a corresponding value of instantaneous plate current (A'). All other points on the grid-voltage curve relate to corresponding points on the plate-current curve.

instantaneous plate current, i_{bx} . All other points on the grid-voltage curve relate to corresponding points on the plate-current curve.

As the grid is driven considerably positive, grid current flows, causing the plate current to be "starved" at the peak of each cycle, thus the plate-current waveform pulse is slightly indented at the top. As the waveform is poor and the distortion high, class-C operation is restricted to r-f amplification where high efficiency is desirable and when the identity of the output waveform to the input waveform is relatively unimportant.

The relation between grid and plate voltages and currents is more fully detailed in the graphs of figures 2 and 3, which illus-

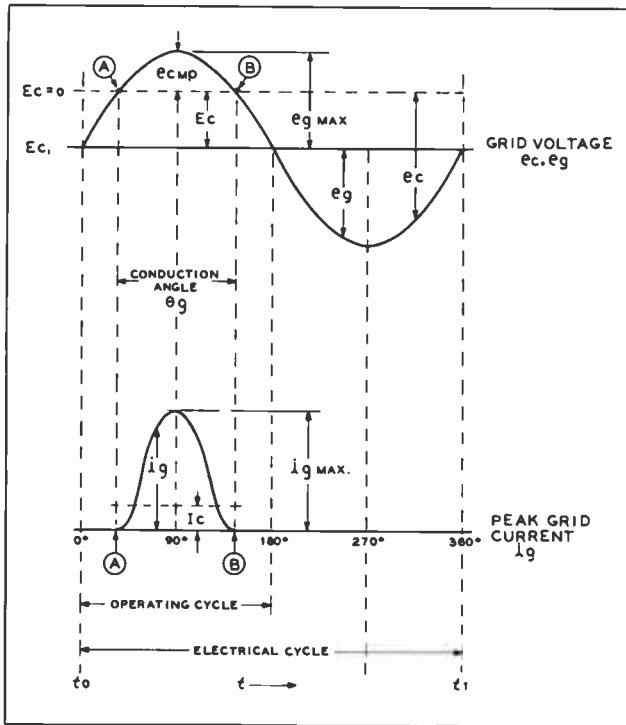

Figure 2
INSTANTANEOUS GRID
VOLTAGE AND CURRENT
OF A CLASS-C R-F
POWER AMPLIFIER

Grid voltage and current variations with respect to time are shown. The grid is negatively biased by the amount E_c . As soon as the positive value of grid exciting voltage (e_g) exceeds E_c (point A) the grid starts to draw current, as it is positive with respect to the filament. Grid current flows from point A to point B of the grid voltage plot. This portion of the grid cycle is termed the conduction angle. Average value of grid current (I_c) may be read on a d-c meter in series with grid return line to bias supply. For typical class-C performance, grid current flows over a portion of the operating cycle, which is less than half the electrical cycle.

trate in detail the various voltage and current variations during one electrical cycle of the exciting signal.

Voltage at the Grid The curves of figure 2 represent the grid voltage and current variations with respect to time. The x-axis for grid voltage is E_{c1} with a secondary axis ($E_{c0} = 0$) above it, the vertical distance between axes representing the fixed grid-bias voltage (E_c). At the beginning of the operating cycle ($t = 0$) the exciting voltage (e_g) is zero and increases in amplitude, until at point A it equals in magnitude the value of the bias voltage. At this point, the instantaneous voltage on the grid of the tube is zero with respect to the cathode, and plate current has already begun to flow (point A in figure 1), as the exciting signal is already greater in magnitude than the cut-off grid voltage (E_{c0}). The relations are normally such that at the crest of the positive grid voltage cycle, e_{cmp} (or $e_{g \text{ max}}$ positive), the grid is driven appreciably positive with respect to the cathode and consequently draws some grid current, i_g .

The d-c component of grid current, I_c , may be read on the grid meter shown in figure 1. The grid draws current only over that portion of the operating cycle when it is positive with respect to the cathode (that portion of the curve above the $E_c = 0$ axis in graph A). This portion of the exciting voltage is termed the *maximum positive grid voltage* (e_{cmp}).

Voltage at the Plate The voltage at the plate of the tube responds to the changes in grid voltage as shown in figure 3. Instantaneous plate voltage (e_b), consists of the d-c plate voltage (E_b) less the a-c voltage drop across the plate load impedance (e_p). As the grid element becomes more positive, a greater flow of electrons reach the plate, instantaneous plate current increases, and the voltage drop across the plate load impedance (R_L) rises. The phase relations are such that the minimum instantaneous plate potential ($e_{b \text{ min}}$) and the maximum instantaneous grid potential ($e_{g \text{ max}}$) occur simultaneously. The corresponding instantaneous plate cur-

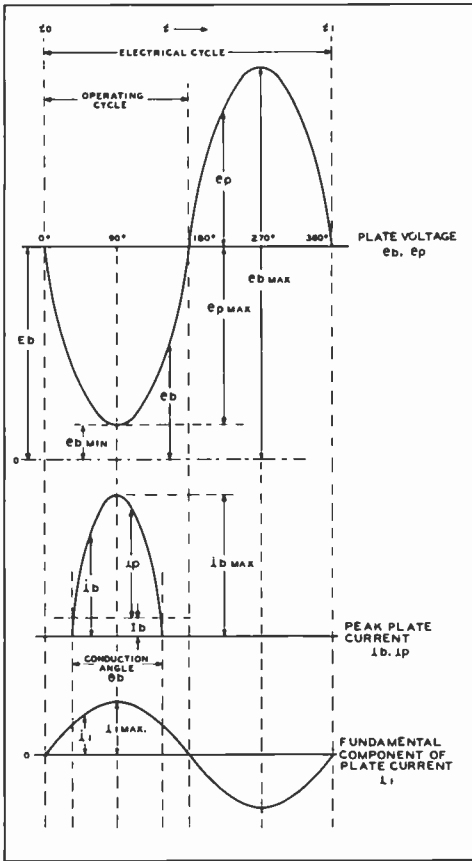

Figure 3

INSTANTANEOUS PLATE VOLTAGE AND CURRENT OF CLASS-C POWER AMPLIFIER

Instantaneous plate voltage and current responds to the changes in grid voltage shown in figure 2. As grid becomes more positive, the peak plate current rises, causing an increased voltage drop across the plate load impedance (R_p , figure 1). Maximum peak plate current flows at condition of minimum instantaneous plate voltage ($e_{p \text{ min}}$) and maximum voltage drop across load impedance ($e_{p \text{ max}}$). Plate-current pulse exists only over a portion of the operating cycle (conduction angle). Usable power is derived from the fundamental component of the plate current which is a sine wave developed across the resonant tank circuit. $e_{p \text{ max}}$ equals $e_{p \text{ min}}$.

rent (i_b) for this sequence is shown in the current plot of figure 3.

As plate current is conducted only between points A and B of the grid-voltage excursion, it can be seen that the plate-cur-

rent pulse exists only over a portion (θ_b) of the complete plate operating cycle. (The operating cycle is taken to be that half-cycle of grid voltage having a positive excursion of the drive voltage.) The opposite half of the electrical cycle is of little interest, as the grid merely assumes a more negative condition and no flow of plate current is possible.

Peak plate current pulses, then, flow as pictured in figure 3 over the conduction angle of each operating cycle. The fundamental component of plate current (i_1) however, is a sine wave since it is developed across a resonant circuit (LC). The resonant circuit, in effect, acts as a "flywheel," holding r-f energy over the pulsed portion of the operating cycle, and releasing it during the quiescent portion of the electrical cycle.

The patterns of grid voltage and current shown in figure 2 are important in determining grid-circuit parameters, and the patterns of plate voltage and current shown in the illustrations can be used to determine plate-circuit parameters, as will be discussed later.

The various manufacturers of vacuum tubes publish data sheets listing in adequate detail various operating conditions for the tubes they manufacture. In addition, additional operating data for special conditions is often available for the asking. It is, nevertheless, often desirable to determine optimum operating conditions for a tube under a particular set of circumstances. To assist in such calculations the following paragraphs are devoted to a method of calculating various operating conditions which is moderately simple and yet sufficiently accurate for all practical purposes. It is based on wave-analysis techniques of the peak plate current of the operating cycle, adapted from Fourier analysis of a fundamental wave and its accompanying harmonics. Considerable ingenuity has been displayed in devising various graphical ways of evaluating the waveforms in r-f power amplifiers. One of these techniques, a *Tube Performance Calculator*, for class-AB₁, class-B, and Class-C service may be obtained at no cost by writing: Application Engineering Dept., Eimac Division of Varian, San Carlos, Calif. 94070.

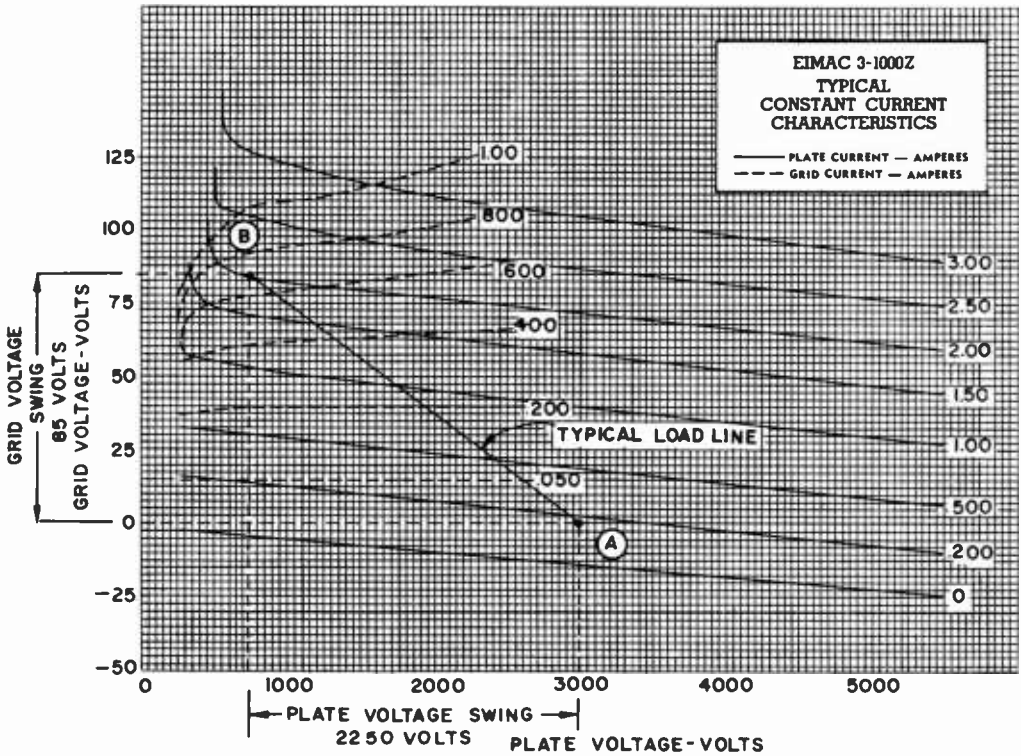

Figure 4

CONSTANT-CURRENT CHART FOR 3-1000Z HIGH- μ TRIODE

The constant-current chart is a plot of constant plate-current lines for various values of grid voltage and plate current. At the start of operation (quiescent point A) the tube rests at a plate voltage of 3000 and zero grid voltage. At a positive grid potential of 85 volts (point B), the plate current has increased to 2 amperes, and the plate voltage has dropped to 750, by virtue of the voltage drop across the plate load impedance. As the grid voltage rises from zero to maximum, the operating point passes from A to B along the load line. By examining representative samples of plate voltage and current along the load line, typical operating characteristics may be derived for the given set of conditions shown on the graph.

7-2 Constant-Current Curves

Although class-C operating conditions can be determined with the aid of conventional grid-voltage versus plate-current operating curves (figure 9, chapter 4), the calculation is simplified if the alternative *constant current* graph of the tube in question is used (figure 4). This representation is a graph of constant plate current on a grid-voltage versus plate-voltage plot, as previously shown in figure 10, chapter 4. The constant-current plot is helpful as the *operating line* of a tuned power amplifier is a straight line on

a set of such curves and lends itself readily to graphic computations. Any point on the operating line, moreover, defines the instantaneous values of plate, screen and grid current which must flow when these particular values of plate, screen and grid voltages are applied to the tube. Thus, by taking off the values of the currents and plotting them against time, it is possible to generate a curve of instantaneous electrode currents, such as shown in figures 1 and 2. An analysis of the curve of instantaneous current values will derive the d-c components of the currents, which may be read on a d-c ammeter. In addition, if the plate current flows through a properly loaded resonant r-f

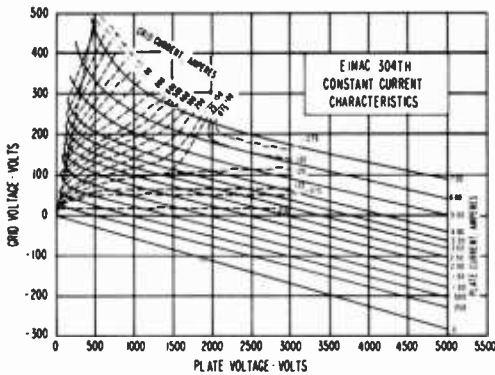

Figure 5

CONSTANT-CURRENT CHART FOR MEDIUM- μ TRIODE

Constant current plot for a 304TH triode with a μ of 20. Note that the lines of constant plate current have a greater slope than the corresponding lines of the high- μ triode (3-1000Z) and that for a given value of positive grid potential, and plate potential, the plate current of this tube is higher than that of the higher- μ tube.

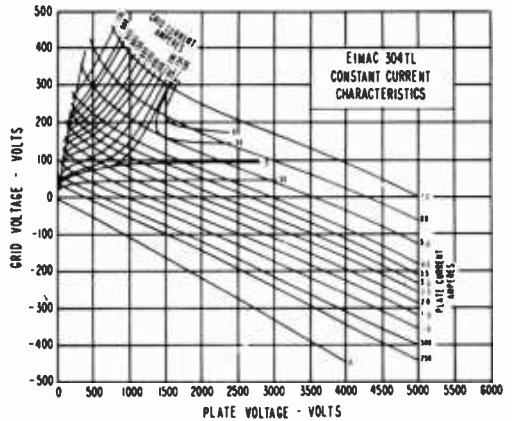

Figure 6

CONSTANT CURRENT CHART FOR LOW- μ TRIODE

Constant-current plot for a 304TL triode with a μ of 12. Note that more plate current at a given plate voltage can be obtained from the low- μ triode without driving the grid into the positive-voltage region. In addition, more bias voltage is required to cut off the plate current at a given plate voltage. With this increased value of bias there is a corresponding increase in grid-voltage swing required to drive up to the zero grid-voltage point on the graph.

circuit, the amount of power delivered to the circuit may be predicted, as well as drive power, and harmonic components of drive and output voltage.

A set of typical constant-current curves for the 304-TH medium- μ triode is shown in figure 5, with a corresponding set of curves for the 304-TL low- μ triode shown in figure 6. The graphs illustrate how much more plate current can be obtained from the low- μ tube without driving the grid into the positive-grid region, as contrasted to the higher- μ tube. In addition, more bias voltage is required to cut off the plate current of the low- μ tube, as compared to the higher- μ tube for a given value of plate voltage. With the higher value of bias, a corresponding increase in grid-voltage swing is required to drive the tube up to the zero grid-voltage point on the curve. Low- μ tubes thus, by definition, have lower voltage gain, and this can be seen by comparing the curves of figures 5 and 6.

Low- μ (3-15) power triodes are chosen for class-A amplifiers and series-pass tubes in voltage regulators, as they operate well over a wide range of load current with low

plate-voltage drop. Medium- μ (15-50) triodes are generally used in r-f amplifiers and oscillators, as well as class-B audio modulators. High- μ (50-200) triodes have high power gain and are often used in cathode-driven ("grounded-grid") r-f amplifiers. If the amplification factor (μ) is sufficiently high, no external bias supply is required, and no protective circuits for loss of bias or drive are necessary. A set of constant-current curves for the 3-500Z high- μ triode is given in figure 7.

The amplification factor of a triode is a function of the physical size and location of the grid structure. The upper limit of amplification factor is controlled by grid dissipation, as high- μ grid structures require many grid wires of small diameter having relatively poorer heat-conduction qualities as compared to a low- μ structure, made up of fewer wires of greater diameter and better heat conductivity. A set of constant-current curves for the 250TH power triode with a sample load line drawn thereon is shown in figure 8.

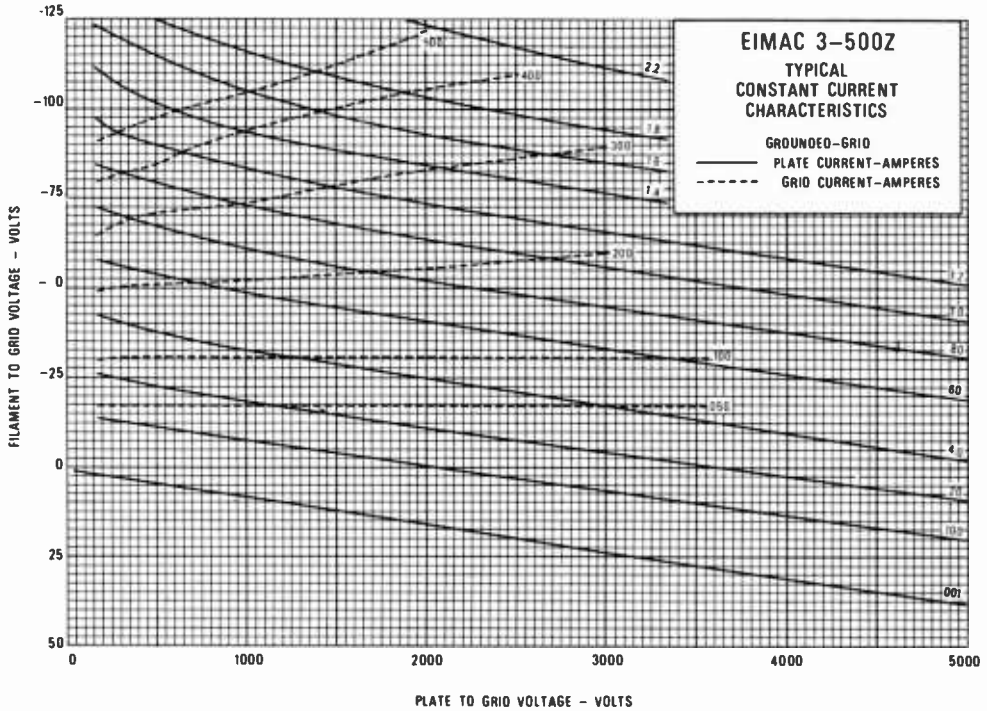

Figure 7

CONSTANT-CURRENT CHART FOR HIGH- μ TRIODE

Constant current plot for a 3-500Z triode with μ of 160. The 3-500Z is considered to be "zero bias" up to a plate potential of about 3000. Resting plate current at this value of plate voltage is approximately 160 milliamperes. This plot is for grounded-grid, cathode-driven use, and grid-voltage axis is defined in terms of filament to grid voltage (negative) instead of grid-to-filament voltage (positive). Grid and screen currents are usually logged on constant-current plots, along with plate current.

7-3 Class-C Amplifier Calculations

In calculating and predicting the operation of a vacuum tube as a class-C radio-frequency amplifier, the considerations which determine the operating conditions are plate efficiency, power output required, maximum allowable plate and grid dissipation, maximum allowable plate voltage, and maximum allowable plate current. The values chosen for these factors will depend on the demands of a particular application of the tube.

The plate and grid currents of a class-C amplifier tube are periodic pulses, the durations of which are always less than 180 degrees. For this reason the average grid cur-

rent, average plate current, power output, driving power, etc., cannot be directly calculated but must be determined by a Fourier analysis from points selected at proper intervals along the line of operation as plotted on the constant-current characteristics. This may be done either analytically or graphically. While the Fourier analysis has the advantage of accuracy, it also has the disadvantage of being tedious and involved.

The approximate analysis which follows has proved to be sufficiently accurate for most applications. This type of analysis also has the advantage of giving the desired information at the first trial. The system is direct in giving the desired information since the important factors, power output, plate efficiency, and plate voltage are arbitrarily selected at the beginning.

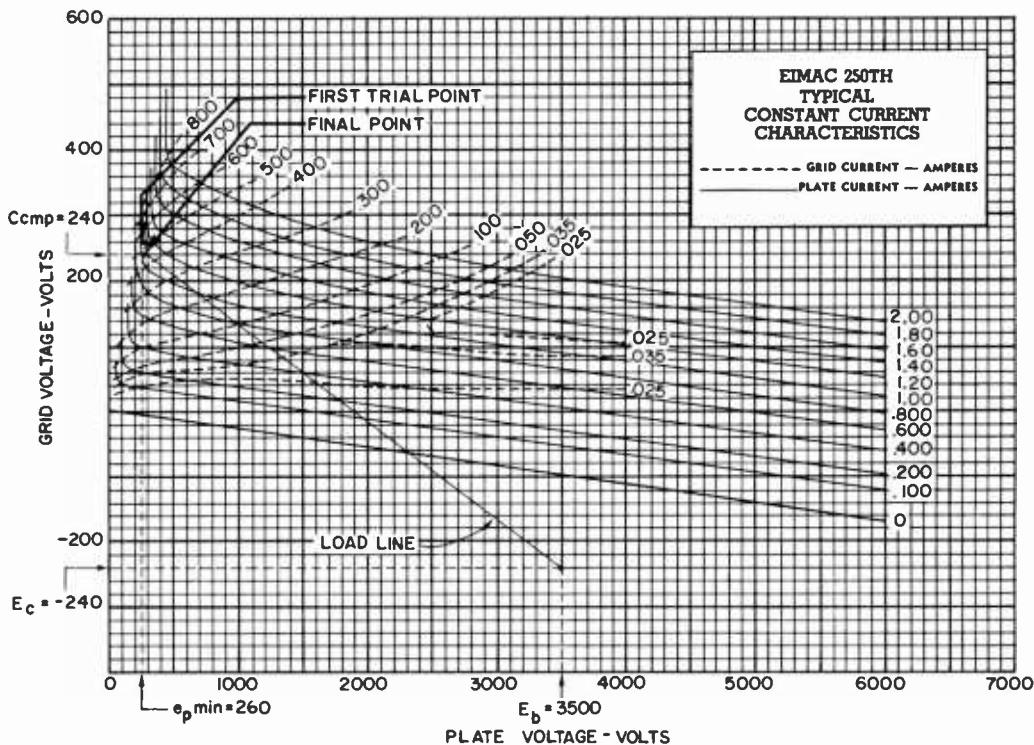

Figure 8
CONSTANT-CURRENT CHART FOR 250TH

Active portion of load line for an Eimac 250TH class-C r-f power amplifier, showing first trial point and final operating point for calculation of operating parameters at a power input of 1000 watts.

Method of Calculation The first step in the method to be described is to determine the power which must be delivered by the class-C amplifier. In making this determination it is well to remember that ordinarily from 5 to 10 percent of the power delivered by the amplifier tube or tubes will be lost in well-designed tank and coupling circuits at frequencies below 20 MHz. Above 20 MHz the tank and circuit losses are ordinarily somewhat above 10 percent.

The plate power input necessary to produce the desired output is determined by the plate efficiency: $P_i = P_o/N_p$, assuming 100-percent tank circuit efficiency.

For most applications it is desirable to operate at the highest practicable efficiency. High-efficiency operation usually requires less-expensive tubes and power supplies, and the amount of external cooling required is

frequently less than for low-efficiency operation. On the other hand, high-efficiency operation usually requires more driving power and involves the use of higher plate voltages and higher peak tube voltages. The better types of triodes will ordinarily operate at a plate efficiency of 75 to 85 percent at the highest rated plate voltage, and at a plate efficiency of 65 to 75 percent at intermediate values of plate voltage.

The first determining factor in selecting a tube or tubes for a particular application is the amount of plate dissipation which will be required of the stage. The total plate dissipation rating for the tube or tubes to be used in the stage must be equal to or greater than that calculated from: $P_p = P_i - P_o$.

After selecting a tube or tubes to meet the power output and plate dissipation requirements it becomes necessary to determine

from the tube characteristics whether the tube selected is capable of the desired operation and, if so, to determine the driving power, grid bias, and grid dissipation.

The complete procedure necessary to determine a set of class-C amplifier operating conditions is given in the following steps:

1. Select the plate voltage, power output and efficiency.
2. Determine plate input from:

$$P_i = P_o / N_p$$
3. Determine plate dissipation from:

$$P_p = (P_i - P_o) / 1.1$$
 (P_p must not exceed maximum rated plate dissipation for selected tube or tubes. Tank circuit efficiency assumed to be 90%).
4. Determine average plate current (I_b) from: $I_b = P_i / E_b$.
5. Determine approximate peak plate current ($i_{b \text{ max}}$) from:

$$i_{b \text{ max}} = 4.9 I_b \text{ for } N_p = 0.85$$

$$i_{b \text{ max}} = 4.5 I_b \text{ for } N_p = 0.80$$

$$i_{b \text{ max}} = 4.0 I_b \text{ for } N_p = 0.75$$

$$i_{b \text{ max}} = 3.5 I_b \text{ for } N_p = 0.70$$

$$i_{b \text{ max}} = 3.1 I_b \text{ for } N_p = 0.65$$

Note: A figure of $N_p = 0.75$ is often used for class-C service, and a figure of $N_p = 0.65$ is often used for class-B and class-AB service.

6. Locate the point on the constant-current chart where the constant-current plate line corresponding to the appropriate value of $i_{b \text{ max}}$ determined in step 5 crosses the point of intersection of equal values of plate and grid voltage. (The locus of such points for all these combinations of grid and plate voltage is termed the *diode line*). Estimate the value of $e_{p \text{ min}}$ at this point.
7. Calculate $e_{b \text{ min}}$ from:

$$e_{b \text{ min}} = E_b - e_{p \text{ min}}$$

8. Calculate the ratio: $i_{1 \text{ max}} / I_b$ from:

$$\frac{i_{1 \text{ max}}}{I_b} = \frac{2 N_p \times E_b}{e_{p \text{ min}}}$$

(where $i_{1 \text{ max}}$ = peak fundamental component of plate current).

9. From the ratio of $i_{1 \text{ max}} / I_b$ calculated in step 8 determine the ratio: $i_{b \text{ max}} / I_b$ from the graph of figure 9.
10. Derive a new value for $i_{b \text{ max}}$ from the ratio found in step 9:

$$i_{b \text{ max}} = (\text{ratio found in step 9}) \times I_b$$
11. Read the values of maximum positive grid voltage, $e_{g \text{ max}}$ and peak grid current ($i_{g \text{ max}}$) from the chart for the values of $e_{p \text{ min}}$ and $i_{b \text{ max}}$ found in steps 6 and 10 respectively.
12. Calculate the cosine of one-half the angle of plate-current flow (one-half the operating cycle, $\theta_p / 2$).

$$\cos \frac{\theta_p}{2} = 2.32 \left(\frac{i_{1 \text{ max}}}{I_b} - 1.57 \right)$$

13. Calculate the grid bias voltage (E_c) from:

$$E_c = \frac{1}{1 - \cos^2 \frac{\theta_p}{2}} \times$$

$$\left[\cos \frac{\theta_p}{2} \left(\frac{e_{b \text{ min}}}{\mu} - e_{c \text{ mp}} \right) - \frac{E_b}{\mu} \right]$$

for triodes.

$$E_{c1} = \frac{1}{1 - \cos^2 \frac{\theta_p}{2}} \times$$

$$\left[- e_{c \text{ mp}} \times \cos \frac{\theta_p}{2} - \frac{E_{c2}}{\mu_s} \right]$$

for tetrodes, where μ_s is the grid-screen amplification factor.

14. Calculate the peak fundamental grid voltage, $e_{g \text{ max}}$ from:

$$e_{g \text{ max}} = e_{c \text{ mp}} - (- E_c)$$
, using negative value of E_c .
15. Calculate the ratio $e_{g \text{ max}} / E_c$ for the values of E_c and $e_{g \text{ max}}$ found in steps 13 and 14.
16. Read the ratio $i_{g \text{ max}} / I_c$ from figure 10 for the ratio $e_{g \text{ max}} / E_c$ found in step 15.

17. Calculate the average grid current (I_c) from the ratio found in step 16 and the value of $i_{g \max}$ found in step 11:

$$I_c = \frac{i_{g \max}}{\text{(ratio found in step 16)}}$$

18. Calculate approximate grid driving power from:

$$P_d = 0.9 e_{g \max} \times I_c$$

19. Calculate grid dissipation from:

$$P_g = P_d - (-E_c \times I_c)$$

(P_g must not exceed the maximum rated grid dissipation for the tube or tubes selected).

Sample Calculation A typical example of class-C amplifier calculation is shown in the following example. Reference is made to figures 8, 9, and 10 in the calculation. The steps correspond to those in the previous section.

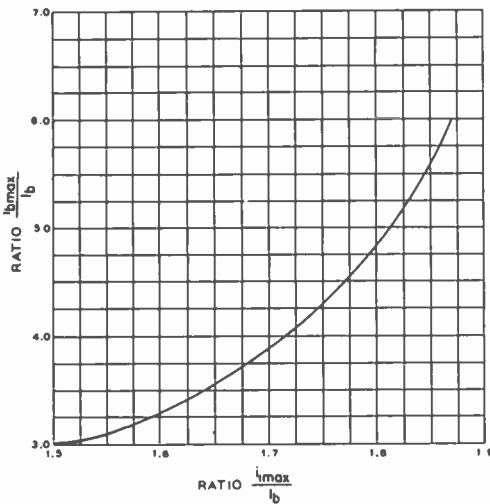

Figure 9

Relationship between the peak value of the fundamental component of the tube plate current, and average plate current; as compared to the ratio of the instantaneous peak value of tube plate current, and average plate current value.

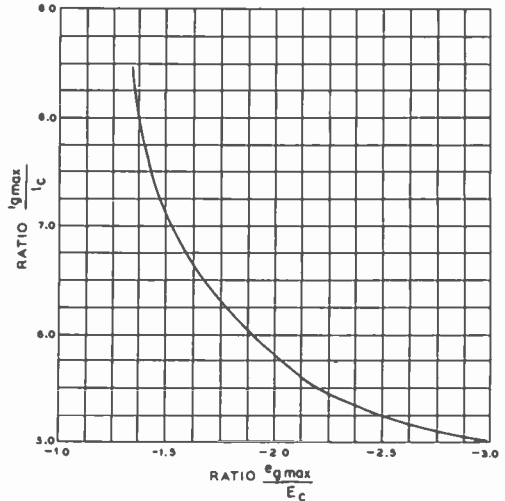

Figure 10

Relationship between the ratio of the peak value of the fundamental component of the grid excitation voltage, and the average grid bias; as compared to the ratio between instantaneous peak grid current and average grid current

1. Desired power output—800 watts.
2. Desired plate voltage—3500 volts.
Desired plate efficiency—80%
($N_p = 0.8$). $P_i = 800/0.8 = 1000$ watts.
3. $P_p = \frac{1000 - 800}{1.1} = 182$ watts.
(Use 250TH; max $P_p = 250W$; $\mu = 37$).
4. $I_b = 1000/3500 = 0.285$ ampere (285 ma). (Maximum rated I_b for 250TH = 350 ma).
5. Approximate $i_{b \max}$: $0.285 \times 4.5 = 1.28$ amp
6. $e_{b \min} = 260$ volts (see figure 8, first trial point).
7. $e_{p \min} = 3500 - 260 = 3240$ volts.
8. $i_{1 \max} / I_b = (2 \times 0.8 \times 3500) / 3240 = 1.73$.
9. $i_{b \max} / I_b = 4.1$ (from figure 9).
10. $i_{b \max} = 4.1 \times 0.285 = 1.17$.
11. $e_{c \text{mp}} = 240$ volts
 $i_{g \max} = 0.43$ amp
(Both read from final point on figure 8).
12. $\cos \frac{\theta_b}{2} = 2.32 (1.73 - 1.57) = 0.37$

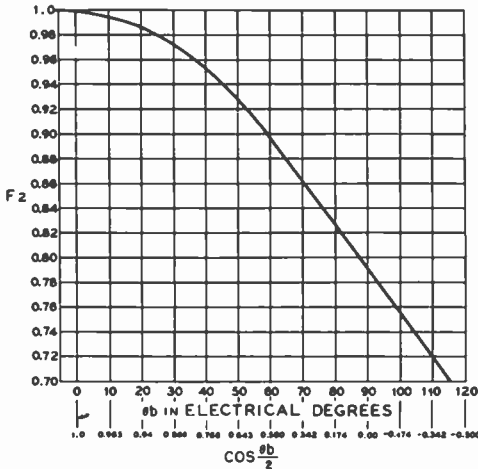

Figure 11

Relationship between factor F_2 and the half-angle of plate-current flow in an amplifier with sine-wave input and output voltage, operating at a grid-bias voltage greater than cutoff

$$\left(\frac{\theta_b}{2} = 68.3^\circ \text{ and } \theta_b = 136.6^\circ \right)$$

13. $E_c = \frac{1}{1 - 0.37} \times$

$$\left[0.37 \left(\frac{3240}{37} - 240 \right) - \frac{3500}{37} \right]$$

= - 240 volts.

14. $e_{g \text{ max}} = 240 - (- 240) = 480$ volts.

15. $e_{g \text{ max}}/E_c = 480/- 240 = -2$.

16. $i_{g \text{ max}}/I_c = 5.75$ (from figure 10).

17. $I_c = 0.43/5.75 = 0.075$ amp (75

18. $P_d = 0.9 \times 480 \times 0.075 = 32.5$ watts.

19. $P_r = 32.5 + (- 240 \times 0.075) = 14.5$ watts (Maximum rated P_g for 250TH = 40 watts).

20. The power output of any type of r-f amplifier is equal to:

$$P_o = \frac{i_{1 \text{ max}} \times e_{p \text{ min}}}{2}$$

($i_{1 \text{ max}}$ can be determined by multiplying the ratio determined in step 8 by

I_b . Thus = $1.73 \times 0.285 = 0.495$).

$P_o = (0.495 \times 3240)/2 = 800$ watts

21. The plate load impedance of any type of r-f amplifier is equal to:

$$R_L = \frac{e_{p \text{ min}}}{i_{1 \text{ max}}}$$

$$R_L = \frac{3240}{0.495} = 6550 \text{ ohms}$$

An alternative equation for the approximate value of R_L is:

$$R_L \cong \frac{E_b}{1.8 \times I_b}$$

$$R_L \cong \frac{3500}{1.8 \times 0.285} = 6820 \text{ ohms}$$

Q of Amplifier Tank Circuit In order to obtain proper plate tank-circuit tuning and low radiation of harmonics from an amplifier it is necessary that the plate tank circuit have the correct Q. Charts giving compromise values of Q for class-C amplifiers are given in the chapter, *Generation of R-F Energy*. However, the amount of inductance required for a special tank-circuit Q under specified operating conditions can be calculated from the following expression:

$$\omega L = \frac{R_L}{Q}$$

where,

ω equals $2 \pi \times$ operating frequency,

L equals tank inductance,

R_L equals required tube load impedance,

Q equals effective tank circuit Q.

A tank circuit Q of 12 to 20 is recommended for all normal conditions. However, if a balanced push-pull amplifier is employed the tank receives two impulses per cycle and the circuit Q may be lowered somewhat from the above values.

Quick Method of Calculating Amplifier Plate Efficiency

The plate-circuit efficiency of a class-B or class-C r-f amplifier is approximately equal to the product of two factors: F_1 , which is

equal to the ratio of $e_{p \max}$ to E_b ($F_1 = e_{p \max}/E_b$) and F_2 , which is proportional to the one-half angle of plate current flow $\theta_b/2$. A graph of F_2 versus both $\theta_b/2$ and $\cos \theta_b/2$ is given in figure 11. Either $\theta_b/2$ or $\cos \theta_b/2$ may be used to determine F_2 . $\cos \theta_b/2$ may be determined either from the procedure previously given for making class-C amplifier computations or it may be determined from the following expression:

$$\cos \frac{\theta_b}{2} = - \frac{\mu E_c + E_b}{\mu \times e_{g \max} - e_{p \max}}$$

Example of Method It is desired to know the one-half angle of plate-current flow and the plate-circuit efficiency for an 812 tube operating under the following class-C conditions which have been assumed from inspection of the data and curves given in the RCA Transmitting Tube Handbook:

1. $E_b = 1100$ volts
 $E_c = -40$ volts
 $\mu = 29$
 $e_{g \max} = 120$ volts
 $e_{p \max} = 1000$ volts
2. $F_1 = \frac{e_{p \max}}{E_b} = 0.91$
3. $\cos \frac{\theta_b}{2} = - \left[\frac{(29 \times 40) + 1100}{(29 \times 120) - 1000} \right] = \frac{60}{2480} = 0.025$
4. $F_2 = 0.79$ (by reference to figure 11)
5. $N_p = F_1 \times F_2 = 0.91 \times 0.79 = 0.72$ (72 percent efficiency)

F_1 could be called the *plate-voltage-swing efficiency factor*, and F_2 can be called the *operating-angle efficiency factor* or the maximum possible efficiency of any stage running with that value of half-angle of plate current flow.

N_p is, of course, only the ratio between power output and power input. If it is desired to determine the power input, exciting power, and grid current of the stage, these can be obtained through the use of steps 7, 8, 9, and 10 of the previously given method for determining power input and output; and knowing that $i_{g \max}$ is 0.095 ampere, the

grid-circuit conditions can be determined through the use of steps 15, 16, 17, 18, and 19.

7-4 Class-B Radio-Frequency Power Amplifiers

Radio-frequency power amplifiers operating under class-B conditions of grid bias and excitation voltage are used in various types of applications in transmitters. The first general application is as a buffer-amplifier stage where it is desired to obtain a high value of power amplification in a particular stage without regard to linearity. A particular tube type operated with a given plate voltage will be capable of somewhat greater output for a certain amount of excitation power when operated as a class-B amplifier than when operated as a class-C amplifier.

Calculation of Operating Characteristics Calculation of the operating conditions for this type of class-B r-f amplifier can be carried out in a manner similar to that described in the previous paragraphs, except that the grid-bias voltage is set on the tube before calculation at the value: $E_c = -E_b/\mu$. Since the grid bias is set at cutoff the one-half angle of plate-current flow is 90° ; hence $\cos \theta_b/2$ is fixed at 0.00. The plate-circuit efficiency for a class-B r-f amplifier operated in this manner can be determined in the following manner:

$$N_p = 78.5 \times \frac{e_{p \max}}{E_b}$$

Note: In reference to figure 3, $e_{p \max}$ is equal in magnitude to $e_{p \min}$ and absolute value should be used.

The "Class-B Linear" The second type of class-B r-f amplifier is the so-called *class-B linear amplifier* which is often used in transmitters for the amplification of a single-sideband signal or a conventional amplitude-modulated wave. Calculation of operating conditions may be carried out in a manner similar to that previously described with the following exceptions: The first trial operating point is chosen on the basis of the 100-percent positive modulation

peak (or PEP condition) of the exciting wave. The plate-circuit and grid-peak voltages and currents can then be determined and the power input and output calculated. Then (in the case for an a-m linear) with the exciting voltage reduced to one-half for the no-modulating condition of the exciting wave, and with the same value of load resistance reflected on the tube, the a-m plate input and plate efficiency will drop to approximately one-half the values at the 100-percent positive modulation peak and the power output of the stage will drop to one-fourth the peak-modulation value. On the negative modulation peak the input, efficiency and output all drop to zero.

In general, the proper plate voltage, bias voltage, load resistance, and power output listed in the tube tables for class-B audio work will also apply to class-B linear r-f application.

Calculation of Operating Parameters for a Class-B Linear Amplifier The class-B linear amplifier parameters may be calculated from constant-current curves, as suggested, or may be derived from the E_b vs I_b curves, as outlined in this section.

Figure 12 illustrates the characteristic curves for an 813 tube. Assume the plate

supply to be 2000 volts, and the screen supply to be 400 volts. To determine the operating parameters of this tube as a class-B linear SSB r-f amplifier, the following steps should be taken:

1. The grid bias is chosen so that the resting plate current will produce approximately 1/3 of the maximum plate dissipation of the tube. The maximum dissipation of the 813 is 125 watts, so the bias is set to allow one-third of this value, or 42 watts of resting dissipation. At a plate potential of 2000 volts, a plate current of 21 milliamperes will produce this figure. Referring to figure 12, a grid bias of -45 volts is approximately correct.
2. A practical class-B linear r-f amplifier runs at an efficiency of about 66% at full output (the carrier efficiency dropping to about 33% with a modulated exciting signal). In the case of single-sideband suppressed-carrier excitation, the linear amplifier runs at the resting or quiescent input of 42 watts with no exciting signal. The peak allowable power input to the 813 is:

$$\text{PEP input power } (P_i) =$$

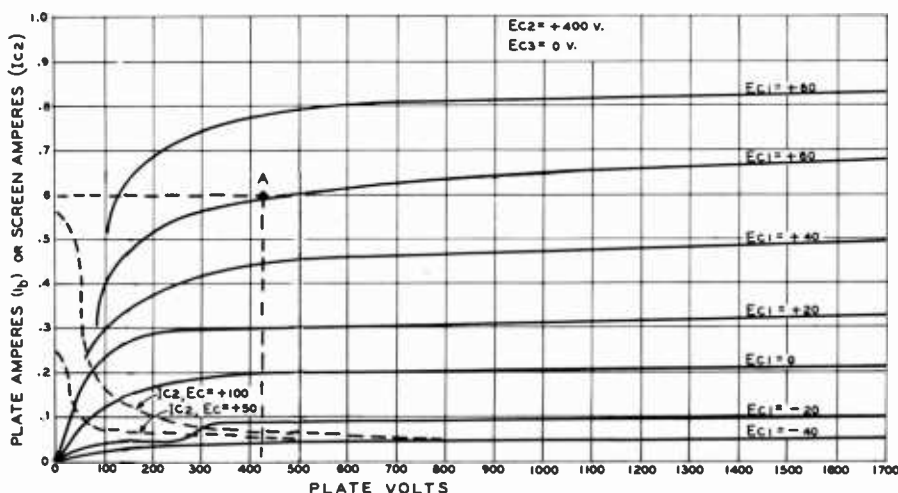

Figure 12

AVERAGE PLATE CHARACTERISTICS OF 813 TUBE

$$\frac{\text{plate dissipation} \times 100}{(100 - \% \text{ plate efficiency})} =$$

$$\frac{125 \times 100}{33} = 378 \text{ watts PEP}$$

3. The maximum d-c signal plate current is:

$$I_{b \text{ max}} = \frac{P_1}{E_b} = \frac{378}{2000} = 0.189 \text{ ampere}$$

(Single-tone drive signal condition)

4. The plate-current conduction angle (θ_b) of the class-B linear amplifier is *approximately* 180° , and the peak plate-current pulses have a maximum value of about 3.14 times $I_{b \text{ max}}$:

$$i_{b \text{ max}} = 3.14 \times 0.189 = 0.593 \text{ amp.}$$

5. Referring to figure 12, a current of about 0.6 ampere (*Point A*) will flow at a positive grid potential of 60 volts and a minimum plate potential of 420 volts. The grid is biased at -45 volts, so a peak r-f grid voltage of 60 + 45 volts, or 105 volts, swing is required.

6. The grid driving power required for the class-B linear stage may be found by the aid of figure 13. It is one-third the product of the peak grid current times the peak grid swing.

$$P_d = \frac{0.015 \times 105}{3} = 0.525 \text{ watt}$$

7. The single-tone (peak) power output of the 813 is:

$$P_o = .785 (E_b - e_{b \text{ min}}) \times I_{b \text{ max}}$$

$$P_o = .785 (2000 - 420) \times 0.189 = 235 \text{ watts PEP}$$

8. The plate load resistance is:

$$R_L \cong \frac{E_b}{1.8 \times I_b} = \frac{2000}{1.8 \times 0.188} = 5870 \text{ ohms}$$

9. If a loaded plate tank circuit Q of 12 is desired, the reactance of the plate tank capacitor of a parallel tuned circuit at resonance is:

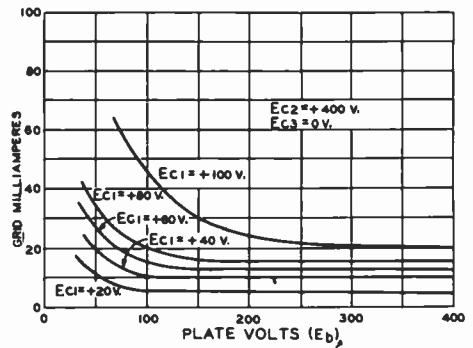

Figure 13

E_{g1} VERSUS E_b CHARACTERISTICS OF 813 TUBE

$$X_c = \frac{R_L}{Q} = \frac{5870}{12} = 490 \text{ ohms}$$

10. For an operating frequency of 4.0 MHz, the effective resonant capacitance is:

$$C = \frac{10^9}{6.28 \times 4.0 \times 490} = 81 \text{ pf}$$

11. The inductance required to resonate at 4.0 MHz with this value of capacitance is:

$$L = \frac{490}{6.28 \times 4.0} = 19.5 \text{ microhenrys}$$

Grid-Circuit Considerations

1. The maximum positive grid potential is 60 volts and the peak r-f grid voltage is 105 volts. Required peak driving power is 0.525 watt. The equivalent grid resistance of this stage is:

$$r_g = \frac{(e_{g \text{ max}})^2}{2 \times P_d} = \frac{105^2}{2 \times 0.525} = 10,000 \text{ ohms}$$

2. As in the case of the class-B audio amplifier the grid resistance of the linear amplifier varies from infinity to a low value when maximum grid current is drawn. To decrease the effect of this resistance excursion, a swamping resistor should be placed across the grid-tank circuit. The value of the resistor

should be dropped until a shortage of driving power begins to be noticed. For this example, a resistor of 3000 ohms is used. The grid circuit load for no grid current is now 3000 ohms instead of infinity, and drops to 2300 ohms when maximum grid current is drawn.

3. A circuit Q of 15 is chosen for the grid tank. The capacitive reactance required is:

$$X_C = \frac{2300}{15} = 154 \text{ ohms}$$

4. At 4.0 MHz the effective capacitance is:

$$C = \frac{10^6}{6.28 \times 4.0 \times 154} = 259 \text{ pf}$$

5. The inductive reactance required to resonate the grid circuit at 4.0 MHz is:

$$L = \frac{154}{6.28 \times 4.0} = 6.1 \text{ microhenrys}$$

6. By substituting the loaded-grid resistance figure in the formula in the first paragraph, the peak grid driving power is now found to be approximately 2.4 watts.

Screen-Circuit Considerations By reference to the plate characteristic curve of the 813 tube, it can be seen that at a minimum plate potential of 420 volts, and a maximum plate current of 0.6 ampere, the screen current will be approximately 30 milliamperes, dropping to one or two milliamperes in the quiescent state. It is necessary to use a well-regulated screen supply to hold the screen voltage at the correct potential over this range of current excursion. The use of an electronically regulated screen supply is recommended.

7-5 Grounded-Grid and Cathode-Follower R-F Power Amplifier Circuits

The r-f power amplifier discussions of Sections 7-3 and 7-4 have been based on the

assumption that a conventional grounded-cathode or cathode-return type of amplifier was in question. It is possible, however, as in the case of a-f and low-level r-f amplifiers to use circuits in which electrodes other than the cathode are returned to ground insofar as the signal potential is concerned. Both the plate-return or cathode-follower amplifier and the *grid-return* or *grounded-grid* amplifier are effective in certain circuit applications as tuned r-f power amplifiers.

Disadvantages of Grounded-Cathode Amplifiers An undesirable aspect of the operation of cathode-return r-f power amplifiers using triode tubes is

that such amplifiers must be neutralized. Principles and methods of neutralizing r-f power amplifiers are discussed in the chapter *Generation of R-F Energy*. As the frequency of operation of an amplifier is increased the stage becomes more and more difficult to neutralize due to inductance in the grid and cathode leads of the tube and in the leads to the neutralizing capacitor. In other words the bandwidth of neutralization decreases as the presence of the neutralizing capacitor adds additional undesirable capacitive loading to the grid and plate tank circuits of the tube or tubes. To look at the problem in another way, an amplifier that may be perfectly neutralized at a frequency of 30 MHz may be completely out of neutralization at a frequency of 120 MHz. Therefore, if there are circuits in both the grid and plate circuits which offer appreciable impedance at this high frequency it is quite possible that the stage may develop a parasitic oscillation in the vicinity of 120 MHz.

Grounded-Grid R-F Amplifiers This condition of restricted neutralization of r-f power amplifiers can be greatly alleviated through the use of a *cathode-driven* or *grounded-grid* r-f stage. The grounded-grid amplifier has the following advantages:

1. The output and input capacitances of a stage are reduced to approximately one-half the value which would be obtained if the same tube or tubes were operated as a conventional neutralized amplifier.

circuit operating conditions of the tube as though it were to operate as a conventional grid-driven amplifier. The second step is to then add in the additional conditions imposed on the original data by the fact that the stage is to operate as a grounded-grid amplifier. This step is the addition of the portion of the drive power contributed by the conversion of drive power to plate output power. This portion of the drive power is referred to as *converted drive power*, or *feedthrough power*. The latter term is misleading, as this portion of drive power does not appear in the plate load circuit of the cathode-driven stage until after it is converted to a *varying-d.c.* plate potential effectively in series with the main amplifier power supply. The converted drive power serves a useful function in linear amplifier service because it swamps out the undesirable effects of nonlinear grid loading and presents a reasonably constant load to the exciter.

Special constant-current curves are often used for grounded-grid operation wherein the grid drive voltage is expressed as the *cathode-to-grid voltage* and is negative in sign. It must be remembered, however, that a negative cathode voltage is equal to a positive grid voltage, and normal constant-current curves may also be employed for cathode-driven computations.

For the first step in the calculations, the procedure given in Section 7-3 is used. For this example, a 3-1000Z "zero bias" triode is chosen, operating at 3000 plate volts at 2000 watts PEP input in class-B service. Computations are as follows:

3-1000Z at 3000 volts class-B

- 1,2,3. $E_b = 3000$
 $P_1 = 2000$ watts PEP
 Let $N_p = 65\%$, an average value for class-B mode
 $P_o = 2000 \times 0.65 = 1300$ W PEP
 $\mu = 200$
4. $I_b = \frac{2000}{3000} = 0.67$ amp
5. Approx. $i_{b \max} = 3.1 I_b$ (for $N_p = 0.65$) = 3.1×2.08 amps.
6. Locate the point on the constant-current chart where the constant-current

line corresponding to the appropriate value of $i_{b \max}$ determined in step 5 inflects sharply upward. Approximate $e_{b \min} = 500$ volts.

7. $e_{p \min} = 3000 - 500 = 2500$ volts.
8. $\frac{i_{1 \max}}{I_b} = \frac{2 \times 0.65 \times 3000}{2500} = 1.56$
9. $\frac{i_{1 \max}}{I_b} = 3.13$ (from figure 9).
10. $i_{b \max} = 3.13 \times 0.67 = 2.1$ amps.

This agrees closely with the approximation made in Step 5.

11. Read the values maximum cathode-to-filament voltage (e_k) and peak grid current ($i_{g \max}$) from the constant-current chart for the values of $e_{b \min}$ and $i_{b \max}$ found in steps 6 and 10 respectively.

$$e_k = -88$$

$$i_{g \max} = 0.8 \text{ amp}$$

12. $\cos \frac{\theta_b}{2} = 2.32 (1.56 - 1.57) = 0$
 (Conduction angle is approximately 180° and $\cos 180^\circ = 0$)
13. $E_c = 0$
14. $e_{k \max} = -88$ volts
- 15-17. For zero bias class-B mode, $I_c \cong 0.25 i_{g \max}$. $I_c \cong 0.25 \times 0.8 = 0.2$ amp. (200 ma)
18. $p_d = 0.9 \times |88| \times 0.2 = 15.8$ watts PEP
19. $p_g = 15.8$ watts PEP
20. $i_{1 \max} = (\text{Ratio of step 8}) \times I_b$
 $i_{1 \max} = 1.56 \times 0.67 = 1.06$ amp

$$P_o \text{ (PEP)} = \frac{1.06 \times 2500}{2}$$

$$= 1325 \text{ watts.}$$

21. $R_L \cong \frac{3000}{1.8 \times 0.67} = 2500$ ohms
22. Total peak drive power,

$$p_k = \frac{e_k \times i_{1 \max}}{2} + p_d$$

$$p_k = \frac{88 \times 1.06}{2} + 15.8 \cong 61 \text{ watts PEP}$$

23. Total power output of the stage is equal to 1325 watts (contributed by 3-1000Z) plus that portion of drive power contributed by the conversion of drive power to plate output power. This is approximately equal to the first term of the equation of step 22.

$$P_o \text{ (PEP) total} = 1325 + 44$$

$$= 1369 \text{ watts}$$

24. Cathode driving impedance of the grounded grid stage is:

$$Z_k \cong \frac{e_k}{i_{1 \text{ max}} + 1.5 \times I_c}$$

$$Z_k \cong \frac{88}{1.06 + 0.3} = 64 \text{ ohms}$$

A summary of the typical operating parameters for the 3-1000 Z at $E_b = 3000$ are

D-c Plate Voltage	3000
Zero-Signal Plate Current	180 ma
(from constant-current chart)	
Max. Signal (PEP) Plate Current	670 ma
Max. Signal (PEP) Grid Current	200 ma
Max Signal (PEP) Drive Power	61 watts
Max. Signal (PEP) Power Input	2000 watts
Max. Signal (PEP) Power Output	1369 watts
(including feedthrough power)	
Plate Load Impedance	2500 ohms
Cathode Driving Impedance	64 ohms

Cathode Tank of G-G or C-F Power Amplifier The cathode tank circuit for either a grounded-grid or cathode-follower r-f power amplifier may be a conventional tank circuit if the filament transformer for the stage is of the low-capacitance high-voltage type. Conventional filament transformers, however, will not operate with the high values of r-f voltage present in such a circuit. If a conventional filament transformer is to be used, the cathode tank coil may consist of two parallel heavy conductors (to carry the high filament current) bypassed at both the ground end and at the tube socket. The tuning capacitor is then placed between filament and

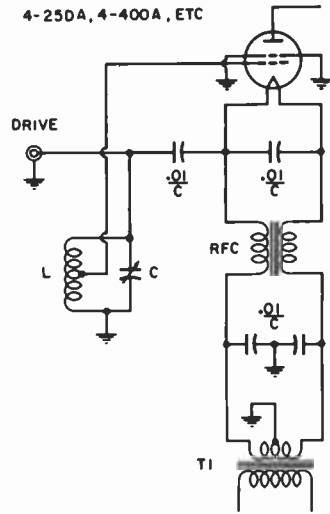

Figure 15
TAPPED INPUT CIRCUIT REDUCES EXCESSIVE GRID DISSIPATION IN G-G CIRCUIT

C = 20 pt per meter wavelength
RFC = Dual-winding on 1/2-inch diameter, 3 1/2-inch long ferrite rod. (Lafayette Radio, N.Y.C. #MS-333).

ground. It is possible in certain cases to use two r-f chokes of special design to feed the filament current to the tubes, with a conventional tank circuit between filament and ground. Coaxial lines also may be used to serve both as cathode tank and filament feed to the tubes for vhf and uhf work.

Control-Grid Dissipation Tetrode tubes may be in **Grounded-Grid Stages** operated as grounded-grid (cathode-driven) amplifiers by tying the grid and screen together and operating the tube as a high- μ triode (figure 15). Combined grid and screen current, however, is a function of tube geometry and may reach destructive values under conditions of full excitation. Proper division of excitation between grid and screen should be as the ratio of the screen-to-grid amplification, which is approximately 5 for tubes such as the 4-250A, 4-400A, etc. The proper ratio of grid/screen excitation may be achieved by tapping the grid at some point on the input circuit, as shown. Grid dissipation is reduced, but the

over-all level of excitation is increased about 30% over the value required for simple grounded-grid operation.

Plate-Return or Cathode-Follower R-F Power Amplifier

Circuit diagram, electrode potentials and currents, and operating conditions for a cathode-follower r-f power amplifier are given in figure 16. This circuit can be used, in addition to the grounded-grid circuit just discussed, as an r-f amplifier with a triode tube and no additional neutralization circuit. However, the circuit will oscillate if the impedance from cathode to ground is allowed to become capacitive rather than inductive or resistive with respect to the operating frequency. The circuit is not recommended except for vhf or uhf work with coaxial lines as tuned circuits since the peak grid swing required on the r-f amplifier stage is approximately equal to the plate voltage on the amplifier tube if high-efficiency operation is desired. This means, of course, that the grid tank must be able to withstand slightly more peak voltage than the plate tank. Such a stage may not be plate modulated unless the driver stage is modulated the same percentage as the final amplifier. However, such a stage may be used as an amplifier of modulated waves (class-B linear) or as a c-w or f-m amplifier.

The design of such an amplifier stage is essentially the same as the design of a grounded-grid amplifier stage as far as the first step is concerned. Then, for the second step the operating conditions given in figure 16 are applied to the data obtained in the first step.

7-6 Class-AB₁ Radio-Frequency Power Amplifiers

Class-AB₁ r-f amplifiers operate under such conditions of bias and excitation that grid current does not flow over any portion of the input cycle. This is desirable, since distortion caused by grid-current loading is absent, and also because the stage is capable of high power gain. Stage efficiency is about 60 percent when a plate-current conduction

Circuit diagram, electrode potentials and currents, and operating conditions for a

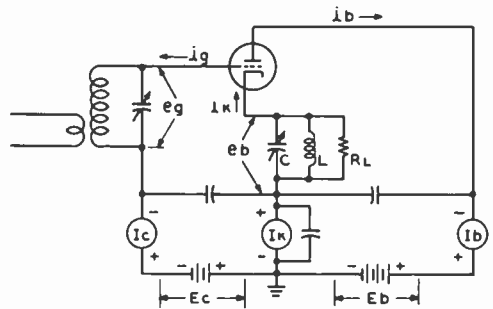

$$\text{POWER OUTPUT TO LOAD} = \frac{e_{b \text{ MIN}} (i_{i \text{ MAX}} + 1.8 I_c)}{2}$$

$$\text{POWER DELIVERED BY OUTPUT TUBE} = \frac{e_{b \text{ MIN}} \times i_{i \text{ MAX}}}{2}$$

$$\text{DRIVE POWER} = \frac{(e_{g \text{ MP}} + e_{b \text{ MIN}}) \times i_{i \text{ MAX}}}{2}$$

$$Z_G \cong \frac{e_{g \text{ MAX}}}{1.8 I_c}$$

$$R_L \cong \frac{E_b}{1.8 \times I_{IK}}$$

Figure 16
CATHODE-FOLLOWER R-F POWER AMPLIFIER

The equations show the relationship between the tube potentials and currents and the input and output power of the stage. The approximate input and output load impedances are also given.

angle of 210° is chosen, as compared to 65 percent for class-B operation.

The level of static (quiescent) plate current for *lowest distortion* is quite high for class-AB₁ tetrode operation. This value is determined by the tube characteristics, and is not greatly affected by the circuit parameters or operating voltages. The maximum d-c potential is therefore limited by the static dissipation of the tube, since the resting plate current figure is fixed. The static plate current of a tetrode tube varies as the 3/2 power of the screen voltage. For example, raising the screen voltage from 300 to 500 volts will double the plate current. The optimum static plate current for minimum distortion is also doubled, since the shape of the *E_c-I_b* curve does not change.

In actual practice, somewhat lower static plate current than optimum may be employed without raising the distortion appreciably, and values of static plate current of 0.6 to 0.8 of optimum may be safely used, depending on the amount of nonlinearity that can be tolerated.

As with the class-B linear stage, the minimum plate voltage swing ($e_{b, min}$) of the class-AB₁ amplifier must be kept above the d-c screen potential to prevent operation in the nonlinear portion of the characteristic curve. A low value of screen voltage allows greater r-f plate voltage swing, resulting in improvement in plate efficiency of the tube. A balance between plate dissipation, plate efficiency, and plate-voltage swing must be achieved for best linearity of the amplifier.

The S-Curve The perfect linear amplifier delivers a signal that is a replica of the input signal. Inspection of the plate-characteristic curve of a typical tube will disclose the tube linearity under class-AB₁ operating conditions (figure 17). The curve is usually of exponential shape, and the signal distortion is held to a small value by operating the tube well below its maximum output, and centering operation over the most linear portion of the characteristic curve.

The relationship between exciting voltage in a class-AB₁ amplifier and the r-f plate-circuit voltage is shown in figure 18. With a small value of static plate current the lower portion of the line is curved. Maximum undistorted output is limited by the point on the line (A) where the instantaneous plate voltage drops down to the screen voltage. This "hook" in the line is caused by current diverted from the plate to the grid and

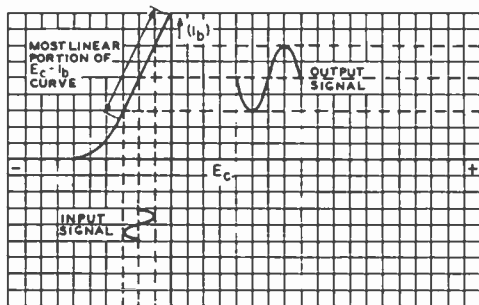
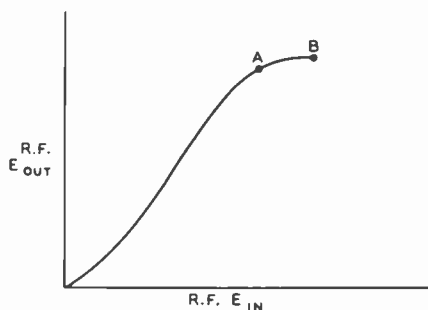

Figure 17

E_c - I_b CURVE

Amplifier operation is confined to the most linear portion of the characteristic curve.



LINEARITY CURVE OF TYPICAL TETRODE AMPLIFIER

At point A the instantaneous plate voltage is swinging down to the value of the screen voltage. At point B it is swinging well below the screen and is approaching the point where saturation, or plate-current limiting takes place.

screen elements of the tube. The characteristic plot of the usual linear amplifier takes the shape of an S-curve. The lower portion of the curve is straightened out by using the proper value of static plate current, and the upper portion of the curve is avoided by limiting minimum plate voltage swing to a point substantially above the value of the screen voltage.

Operating Parameters for the Class-AB₁ Linear Amplifier

The approximate operating parameters may be obtained from the constant-current curves (E_c - E_b) or the E_c - I_b curves of the tube in question (figure 19). The following example will make use of the latter information, although equivalent results may be obtained from constant-current curves. An operating load line is first approximated. One end of the load line is determined by the d-c operating voltage of the tube, and the required static plate current. As a starting point, let the product of the plate voltage and current approximate the plate dissipation of the tube. Assuming a 4-400A tetrode is used, this end of the load line will fall on point A (figure 19). Plate power dissipation is 360 watts (3000V at 120 ma). The opposite end of the load line will fall on a point determined by the minimum

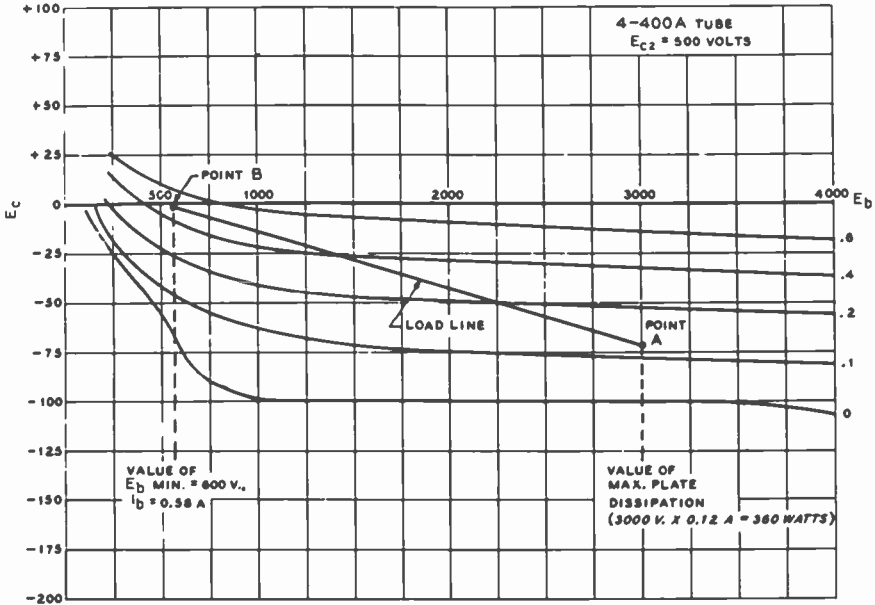

Figure 19

OPERATING PARAMETERS FOR TETRODE LINEAR AMPLIFIER ARE OBTAINED FROM CONSTANT-CURRENT CURVES.

instantaneous plate voltage, and by the maximum instantaneous plate current. The minimum plate voltage, for best linearity

should be considerably higher than the screen voltage. In this case, the screen voltage is 500, so the minimum plate voltage excursion should be limited to 600 volts. Class-AB₁ operation implies no grid current, therefore the load line cannot cross the $E_r = 0$ line. At the point $e_{b \text{ min}} = 600$, $E_r = 0$, the maximum instantaneous plate current is 580 ma (Point B).

Each point at which the load line crosses a grid-voltage axis may be taken as a point for construction of the $E_r - I_b$ curve, just as was done in figure 22, chapter 6. A constructed curve shows that the approximate static bias voltage is -74 volts, which checks closely with point A of figure 19. In actual practice, the bias voltage is set to hold the actual dissipation slightly below the maximum limit of the tube.

The single tone PEP power output is:

$$P_o = \frac{(E_b - e_{b \text{ min}}) \times i_{b \text{ max}}}{4}$$

$$\frac{(3000 - 600) \times 0.58}{4} = 348 \text{ watts}$$

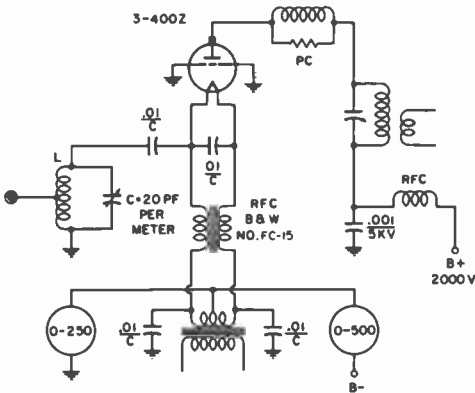

Figure 20

SIMPLE GROUNDED-GRID LINEAR AMPLIFIER

Tuned cathode (L-C) is required to prevent distortion of driving-signal waveform.

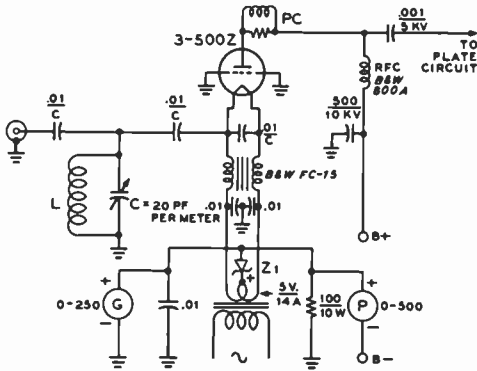

Figure 21

ZENER-DIODE BIAS FOR GROUNDED-GRID STAGE

The resting plate current of a grounded stage may be reduced by inclusion of a Zener diode in the filament return circuit. At a plate potential of 3250 volts, for example, a Zener bias of 4.7 volts reduces the resting plate current of the 3-500Z from 160 to approximately 90 milliamperes. A 1N4551 Zener may be used, bolted to the chassis for a heat sink.

The plate current conduction angle efficiency factor for this class of operation is 0.73, and the actual plate circuit efficiency is:

$$N_p = \frac{E_b - e_{b \text{ min}}}{E_b} \times 0.73 = 58.4\%$$

The peak power input to the stage is therefore:

$$\frac{P_o}{N_p} \times 100 = \frac{348}{58.4} = 595 \text{ watts PEP}$$

The peak plate dissipation is:

$$595 - 348 = 247 \text{ watts}$$

(Note: A 4-250A may thus be used in lieu of the 4-400A as peak plate dissipation is less than 250 watts, provided resting plate current is lowered to 70 ma.)

It can be seen that the limiting factor for either the 4-250A or 4-400A is the static plate dissipation, which is quite a bit higher than the operating dissipation level. It is possible, at the expense of a higher level of

distortion, to drop the static plate dissipation and to increase the screen voltage to obtain greater power output. If the screen voltage is set at 800, and the bias increased sufficiently to drop the static plate current to 70 ma, the single-toned d-c plate current may rise to 300 ma, for a power input of 900 watts. The plate circuit efficiency is 55.6 percent, and the power output is 500 watts. Static plate dissipation is 210 watts, within the rating of either tube.

At a screen potential of 500 volts, the maximum screen current is less than 1 ma, and under certain loading conditions may be negative. When the screen potential is raised to 800 volts maximum screen current is 18 ma. The performance of the tube depends on the voltage fields set up in the tube by the cathode, control grid, screen grid, and plate. The quantity of current, flowing in the screen circuit is only incidental to the fact that the screen is maintained at a positive potential with respect to the electron stream surrounding it.

The tube will perform as expected as long as the screen current, in either direction, does not create undesirable changes in the screen voltage, or cause excessive screen dissipation. Good regulation of the screen supply is therefore required. Screen dissipation is highly responsive to plate loading conditions and the plate circuit should always be adjusted so as to keep the screen current below the maximum dissipation level as established by the applied voltage.

7-7 Grounded-Grid Linear Amplifiers

The popularity of grounded-grid (cathode-driven) linear amplifiers for SSB service is unique in the Amateur Service. Elimination of costly and bulky bias and screen power supplies make the "g-g" amplifier an economical and relatively light-weight power unit.

A typical grounded-grid amplifier is shown in figure 20. The driving signal is applied between the grid and the cathode, with the grid held at r-f ground potential. The control grid serves as a shield between the cathode and the plate, thus making neutral-

ization unnecessary at medium and high frequencies. High- μ triodes and triode-connected tetrodes may be used in this configuration. Care must be taken to monitor the #1-grid current of the tetrode tubes as it may run abnormally high in some types (4X150A family) and damage to the tube may possibly result unless a protective circuit of the form shown in figure 21 is used.

"Zero-bias" triodes (811-A, 3-400Z and 3-1000Z) and certain triode-connected tetrodes (813 and 4-400A, for example) require no bias supply and good linearity may be achieved with a minimum of circuit components. An improvement of the order of 5 to 10 decibels in intermodulation distortion may be gained by operating such tubes in the grounded-grid mode in contrast to the same tubes operated in class-AB₁, grid-driven mode. The improvement in the distortion figure varies from tube type to tube type, but all so-called "grounded-grid" triodes and triode-connected tetrodes show some degree of improvement in distortion figure when cathode-driven as opposed to grid-driven service.

Cathode-Driven High- μ Triodes High- μ triode tubes may be used to advantage in cathode-drive (grounded-grid) service. The inherent shielding of a high- μ tube is better than that of a low- μ tube and the former provides better gain per stage and requires less drive than the latter because of less feedthrough power. Resistive loading of the input or driving circuit is not required because of the constant feedthrough power load on the exciter as long as sufficient Q exists in the cathode tank circuit. Low- μ triodes, on the other hand, require extremely large driving signals when operated in the cathode-driven configuration, and stage gain is relatively small. In addition, shielding between the input and output circuits is poor compared to that existing in high- μ triodes.

Bias Supplies for Medium- μ G-G Amplifiers Medium- μ triode tubes that require grid bias may be used in cathode-driven service if the grid is suitably bypassed to ground and placed at the proper negative d-c potential. Bias supplies for such circuits,

R-F LINEAR AMPLIFIER SERVICE FOR SSB AND CW
CATHODE-DRIVEN (GROUNDED-GRID)
CLASS-B MODE

TUBE	PLATE VOLTAGE E _b	FIL V A	APPROX. ZERO SIG. PLATE I _{b0} CURRENT	MAX. SIG. PLATE I _b CURRENT	MAX. SIG. GRID I _{c1} CURRENT	DRIVING IMPEDAN. R _k	PLATE LOAD RL IMPEDAN.	MAX. SIG. DRIVING POWER W.	PEP PLATE INPUT POWER W.	USEFUL OUTPUT POWER W.	AVERAGE PLATE DISSIPAT. P _d	APPROX. 3 λ ORDER IMD-D _b
811A	1250 1700	7.5 4	18 30	175 160	28 28	320	3600 5200	12 15	220 270	135 175	70 85	-33 -28
572 B T-160L	2400	7.5 4	20	250	45	215	4500	30	600	350	160	-28
813	2000 2500	10 5	20 30	200	50 50	270	5000 7000	10 11	400 500	270 350	130 150	-30 -33
3-400Z 8163	2000 2500 3000	5 14.5	62 73 100	400 400 333	148 142 120	120	2750 3450 4750	— — 32	800 1000 1000	445 600 855	355 400 345	-40 -35 -32
3-500Z	2000 2500 3000	5 14.5	95 130 160	400 400 370	130 120 115	115	2750 3450 5000	— — 30	800 1000 1100	500 600 750	300 400 350	-38 -33 -30
3-1000Z 8164	2500 3000 3500	7.5 21	182 175 200	800 670 750	270 220 245	85 85 85	1800 2400 2600	95 85 85	2000 2000 2600	1250 1250 1770	750 750 830	-38 -35 -30
3CX1000A7 8283	2500 3000	5 30	200 310	875 800	590 320	41 42	1100 1870	78 87	2200 2400	1000 1200	1000 1000	-32 -32
4-125A	2000 2500 3000	5 8.3	10 15 20	105 110 115	55 55 55	340 340 340	10500 13500 15700	18 18 18	210 275 345	145 190 240	65 85 100	— — —
4-400A	2000 2500 3000	5 14.5	55 60 70	265 270 330	100 100 108	180 150 140	3950 4500 5600	38 39 40	530 875 990	325 435 572	200 225 390	— — -30
4-1000A	3000 4000 5000	7.5 21	80 90 120	700 875 540	200 200 115	104 108 110	2450 2450 5500	130 105 70	2100 2700 2700	1475 1870 1900	750 730 700	-34 -34 —

Figure 22

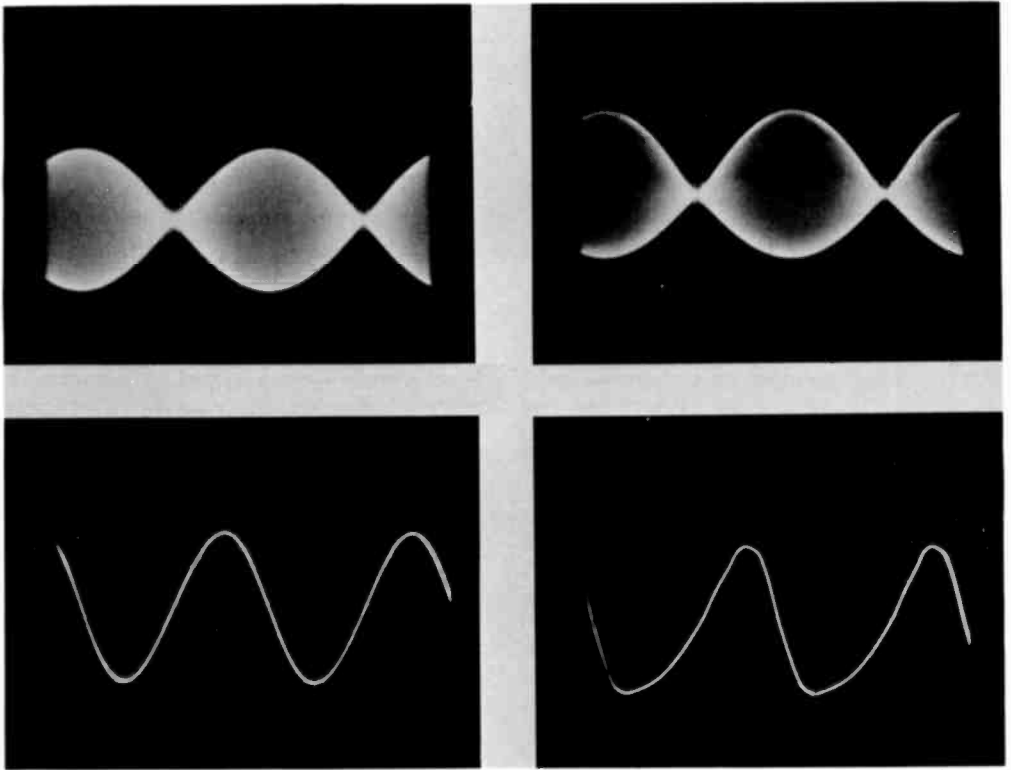

Figure 23

Waveform distortion caused by half-cycle loading at cathode of grounded-grid amplifier may be observed (right) whereas undistorted waveform is observed with tuned cathode circuit (left). Two-tone tests at 2.0 MHz proved the necessity of using a cathode tank circuit for lowest inter-modulation distortion.

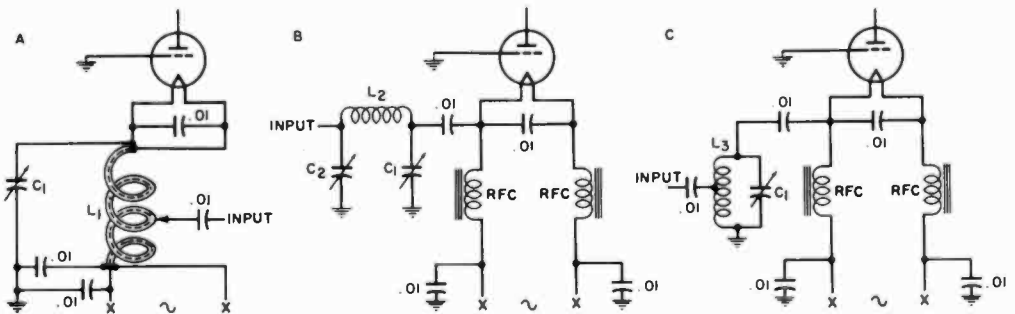

Figure 24

Tuned cathode network for cathode-driven circuit may take form of bifilar coil (A), pi-network (B), or shunt LC circuit (C). Circuit Q of at least 2 is recommended. Capacitor C₁ may be a 3-gang broadcast-type unit. Coils L₁, L₂, or L₃ are adjusted to resonate to the operating frequency with C₁ set to approximately 13 pf-per meter wavelength. Capacitor C₂ is approximately 1.5 times the value of C₁. The input taps on coils L₁ and L₂ or the capacitance of C₂ are adjusted for minimum SWR on coaxial line to the exciter.

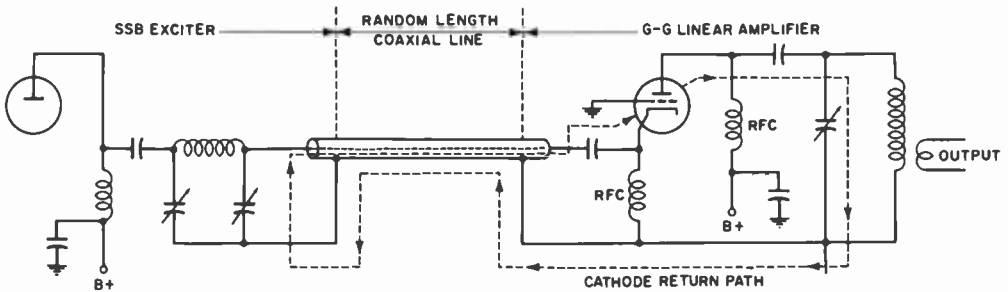

Figure 25

Untuned cathode circuit of grounded-grid amplifier offers high-impedance path to the r-f current flowing between plate and cathode of the amplifier tube. The alternative path is via the interconnecting coaxial line and tank circuit of the exciter. Waveform distortion of the driving signal and high intermodulation distortion may result from use of alternative input circuit.

however, must be capable of good voltage regulation under conditions of grid current so that the d-c bias value does not vary with the amplitude of the grid current of the stage. Suitable bias supplies for this mode of operation are shown in the *Power Supply* chapter of this Handbook. *Zener bias* (figure 21) may be used for low values of bias voltage. Approximate values of bias voltage for linear amplifier service data may be obtained from the audio data found in most tube manuals, usually stated for push-pull class-AB₁ or AB₂ operation. As the tube "doesn't know" whether it is being driven by an audio signal or an r-f signal, the audio parameters may be used for linear service, but the stated d-c currents should be divided by two for a single tube, since the audio data is usually given for two tubes. Grounded-grid operating data for popular triode and tetrode tubes is given in figure 22.

The Tuned Cathode Circuit Input waveform distortion may be observed at the cathode of a grounded-grid linear amplifier as the result of grid- and plate-current loading of the input circuit on alternate half-cycles by the single-ended stage (figure 23). The driving source thus "sees" a very low value of load impedance over a portion of the r-f cycle and an extremely high impedance over the remaining portion of the cycle. Unless the output voltage regulation of the r-f source is very good, the portion of the wave on the loaded part of

the cycle will be degraded. This waveform distortion contributes to intermodulation distortion and also may cause TVI difficulties as a result of the harmonic content of the wave. Use of a tuned cathode circuit in the grounded-grid stage will preserve the waveform as shown in the photographs. The tuned-cathode circuit need have only a Q of 2 or more to do the job, and should be resonated to the operating frequency of the amplifier. Various versions of cathode tank circuits are shown in figure 24.

In addition to reduction of waveform distortion, the tuned-cathode circuit provides a short r-f return path for plate current pulses from plate to cathode (figure 25). When the tuned circuit is not used, the r-f return path is via the outer shield of the coaxial line, through the output capacitor of the exciter plate-tank circuit and back to the cathode of the linear amplifier tube via the center conductor of the coaxial line. This random, uncontrolled path varies with the length of interconnecting coaxial line, and permits the outer shield of the line to be "hot" compared to r-f ground.

7-8 Intermodulation Distortion

If the output signal of a linear amplifier is an exact replica of the exciting signal there will be no distortion of the original signal and no distortion products will be generated in the amplifier. Amplitude distortion of the signal exists when the output

signal is not strictly proportional to the driving signal and such a change in magnitude may result in *intermodulation distortion* (IMD). IMD occurs in any nonlinear device driven by a complex signal having more than one frequency. A voice signal (made-up of a multiplicity of tones) will become blurred or distorted by IMD when amplified by a nonlinear device. As practical linear amplifiers have some degree of IMD (depending on design and operating parameters) this disagreeable form of distortion exists to a greater or lesser extent on most SSB signals.

A standard test to determine the degree of IMD is the *two-tone test*, wherein two radio-frequency signals of equal amplitude are applied to the linear equipment, and the resulting output signal is examined for spurious signals, or unwanted products. These unwanted signals fall in the fundamental-signal region and in the various har-

monic regions of the amplifier. Signals falling outside the fundamental-frequency region are termed *even-order products*, and may be attenuated by high-Q tuned circuits in the amplifier. The spurious products falling close to the fundamental-frequency region are termed *odd-order products*. These unwanted products cannot be removed from the wanted signal by tuned circuits and show up on the signal as "splatter," which can cause severe interference to communication in an adjacent channel. Nonlinear operation of a so-called "linear" amplifier will generate these unwanted products. Amateur practice calls for suppression of these spurious products to better than 30 decibels below peak power level of one tone of a two-tone test signal. Commercial practice demands suppression to be better than 40 decibels below this peak level.

Additional data on IMD and two-tone test techniques is given in chapter 16.

The Oscilloscope

The *cathode-ray oscilloscope* (also called *oscillograph*) is an instrument which permits visual examination of various electrical phenomena of interest to the electronic engineer. Instantaneous changes in voltage, current and phase are observable if they take place slowly enough for the eye to follow, or if they are periodic for a long enough time so that the eye can obtain an impression from the screen of the cathode-ray tube. In addition, the cathode-ray oscilloscope may be used to study any variable (within the limits of its frequency-response characteristic)

which can be converted into electrical potentials. This conversion is made possible by the use of some type of *transducer*, such as a vibration pickup unit, pressure pickup unit, photoelectric cell, microphone, or a variable impedance. The use of such a transducer makes the oscilloscope a valuable tool in fields other than electronics.

8-1 A Modern Oscilloscope

For the purpose of analysis, the operation of a modern oscilloscope will be described.

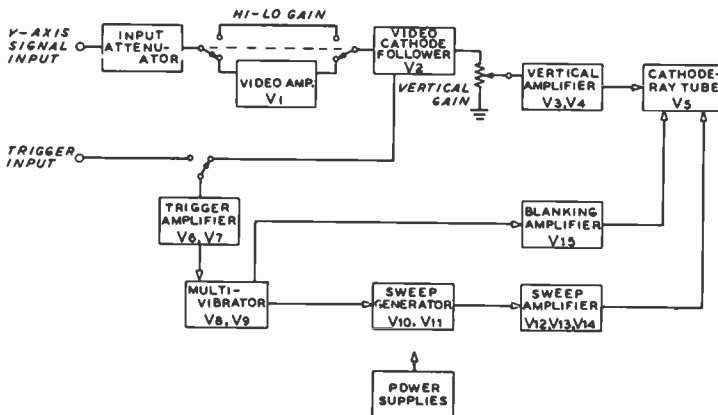

Figure 1

BLOCK DIAGRAM OF A MODERN OSCILLOSCOPE

This simplified block diagram of a Tektronix oscilloscope features triggered sweep and a blanking circuit that permit observation of single pulses as short as 0.1 microsecond.

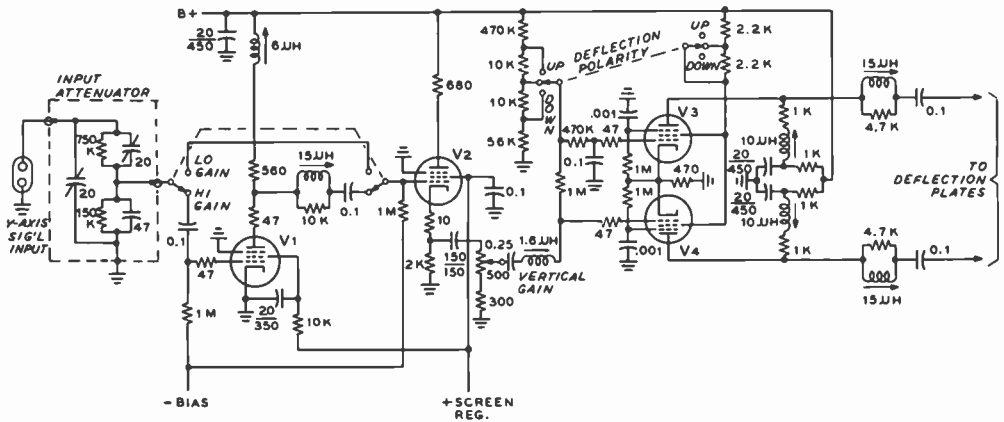

Figure 2

VERTICAL AMPLIFIER

The vertical amplifier is capable of passing sine waves from 10 Hz to 10 MHz. Compensated input attenuator and peaking circuits provide gain that is essentially independent of frequency. Deflection amplifier serves as phase inverter to provide push-pull signal to deflection plates of cathode-ray tube. Deflection polarity switch permits greater upward or downward deflection of pattern to accommodate reversed polarity of input wave.

The simplified block diagram of the instrument is shown in figure 1. This oscilloscope is capable of reproducing sine waves from 10 Hz to 10 MHz and pulses as short as 0.1 microsecond may be observed. The sweep speed is continuously variable, and the electron beam of the cathode-ray tube can be moved vertically or horizontally, or the movements may be combined to produce composite patterns on the screen. As shown in the diagram, the cathode-ray tube receives signals from two sources: the vertical (Y-axis) the sweep (X-axis) amplifiers, and also receives blanking pulses that remove unwanted return-trace signals from the screen. The operation of the cathode-ray tube has been covered in an earlier chapter and the auxiliary circuits pertaining to signal presentation will be discussed here.

The Vertical Amplifier The incoming signal to be displayed is applied to the vertical amplifier (figure 2). An input attenuator (compensated to provide attenuator that is essentially independent of signal frequency) permits the gain of the amplifier to be adjusted in calibrated steps. The signal is then amplified by the wideband (video) preamplifier (V₁), or is shunted around the

preamplifier depending on the amount of amplification needed. The preamplifier is designed to pass the wide frequency band desired by the use of peaking coils in the plate circuit, which enhance the high-frequency response, in addition to large value coupling capacitors which ensure good low-frequency response (see chapter 6, section 6 Video Frequency Amplifiers). The signal then passes through a cathode-follower stage (V₂) to the vertical amplifier. The cathode follower serves as an impedance transformer so that a low-impedance vertical gain control may be used. It is necessary that the potentiometer have a low value so that stray capacitances do not appreciably affect the frequency response as the control is rotated. The original deflection polarity of the signal is reversed when two stages of amplification are used, resulting in a downward deflection of the oscilloscope pattern for positive input polarity. A deflection polarity switch is used to change the operating bias and screen voltage on the cathode-coupled push-pull vertical amplifier tubes (V₃, V₄) permitting greater undistorted upward or downward deflection. The amplified signal is coupled from the plate circuit of the vertical amplifier through a peaking circuit that affords optimum

transient response rather than best frequency response, which has been previously determined in the preamplifier stages.

The Time-Base Circuitry Investigation of electrical waveforms by the use of a cathode-ray tube requires that some means be readily available to determine the variation in these waveforms with respect to time. An X-axis *time base* on the screen of the cathode-ray tube shows the variation in amplitude of the input signal with respect to time. This display is made possible by a *time-base generator (sweep generator)* which moves the spot across the screen at a constant rate from left to right between selected points, returns the spot almost instantaneously to its original position, and repeats this procedure at a specified rate (referred to as the *sweep frequency*).

The Sweep-Trigger Circuit—An external *synchronizing impulse* (which may be the presented signal) initiates the horizontal sweep circuits of the oscilloscope, deflecting the beam of the cathode-ray tube across the screen at uniform rate, starting each sweep

in synchronism with the trigger impulse. A *trigger amplifier* (V_6, V_7) enhances the trigger pulse and selects the proper polarity of the pulse. To convert the various shapes of trigger impulses into square waves of controllable duration suitable for operating the sweep generator and unblanking the cathode-ray tube, a *flip-flop multivibrator* type of pulse generator is used (figure 3). The frequency of pulse generation of the multivibrator is controlled by the external negative trigger signal. The multivibrator consists of two tubes (V_8, V_9) with one tube in a conducting state and the other nonconducting. When a trigger impulse is received, the negative pulse lowers the plate potential of the nonconducting tube (V_8) and also decreases the grid bias of V_9 via the switchable coupling capacitor (*sweep-speed control*). The first tube conducts and the second tube is driven toward cutoff by the buildup of voltage in the coupling capacitor between the two tubes. This condition is maintained until the switchable sweep-speed capacitor is discharged, thus raising the grid voltage of V_9 to such a point that the tube starts to conduct. This lowers the plate potential of V_9 , carrying with it the direct-coupled grid of V_8 and starting a regenerative cycle which ends with V_9 conducting and V_8 cut off—the condition which existed before the trigger pulse occurred. Thus the plate of V_8 produces a square negative pulse and simultaneously the plate of V_9 produces a square positive pulse. The negative pulse is used to control the operation of the sweep generator and the unblanking circuit of the cathode-ray tube. The positive pulse may be used to furnish gate voltage available at the panel of the instrument to trigger auxiliary circuits.

The Blanking Circuit—During the wait-period between trigger pulses, the bias on the cathode-ray tube is such that the tube is completely cut off. As soon as a trigger appears and the sweep starts, it is necessary to provide a positive pulse on the grid of the cathode-ray tube and thus turn on the electron beam. This pulse must have extremely rapid rise time and a very flat top so that the brightness of the image is uniform. To secure a pulse of this nature, the negative pulse from the multivibrator is passed through a cathode-follower *blanking ampli-*

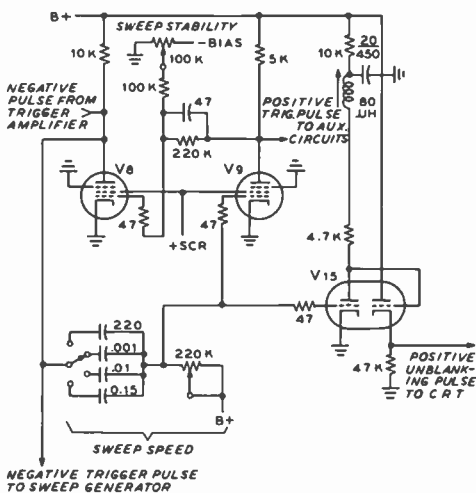

Figure 3

TRIGGER AND UNBLANKING CIRCUIT

Flip-flop multivibrator (V_8, V_9) is triggered externally and generates negative trigger pulse to start sweep generator. Impulse rate is controlled by switchable sweep speed capacitor bank. Positive trigger pulse unblanks cathode-ray tube by reducing cutoff bias on the grid of the cathode ray tube

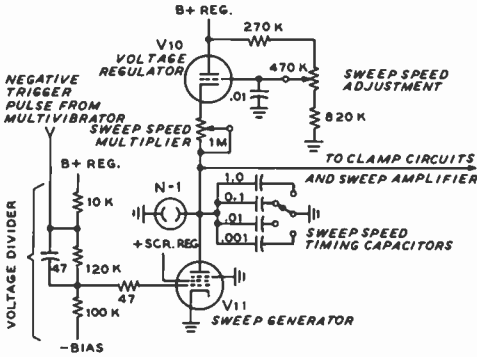

Figure 4

SWEEP GENERATOR

Each sweep of this triggered sweep circuit is started independently of the preceding sweep by a trigger pulse received from the multivibrator circuit. Sweep-speed timing capacitors are ganged with sweep-speed circuit of multivibrator. Timing voltage is derived from voltage regulator to ensure sweep accuracy.

fier (V_{15}) which provides a pulse of proper amplitude and rise time.

The Sweep Generator The voltage necessary to obtain a linear time base may be generated by the circuit of figure 4.

In this representative *triggered sweep* circuit each sweep is started independently of the preceding sweep by a trigger, or synchronizing, pulse received from the multivibrator circuit. When no trigger is received the cathode-ray tube potentials position the beam at the left end of the horizontal trace. When the trigger signal arrives, the beam goes linearly to the right in a time interval determined by the length of the trigger pulse. At the end of each sweep,



Figure 5

SAWTOOTH WAVEFORM

Recurrent or sawtooth sweep waveform is used in inexpensive oscilloscopes. Sawtooth may be generated by gas sweep tube, such as the 884, and is usually synchronized with input signal.

the beam returns to the left of the screen to wait another trigger signal. It is this variable waiting period which makes the sweep time independent of the signal period, permitting the oscilloscope to view pulses and other short duration signals where the length of the pulse is very short compared to the space between the pulses.

Some inexpensive oscilloscopes employ a *recurrent or sawtooth sweep* such as that which is generated by a gas tube or other similar device that synchronizes the sweep with the input signal. The sweep time is thus equal to, or a multiple of, the signal period. The circuit of figure 4 may be modified to produce a sawtooth sweep by the omission of the trigger signal and adjustment of the multivibrator frequency to synchronize with the period of the observed signal. The sweep voltage necessary to produce the sawtooth sweep is shown in figure 5. The sweep occurs as the voltage varies from A to B, and the return trace as the voltage varies from B to C. At high sweep frequencies, the return trace is an appreciable portion of the sweep time.

Operation of the Sweep Generator—The sweep generator (V_{11} , figure 4) is held in a conducting state by the positive grid bias derived from the voltage divider in the grid circuit. The plate voltage of the sweep generator is low, and the switchable sweep-speed timing capacitor is essentially uncharged. The negative trigger pulse from the multivibrator rapidly cuts off V_{11} allowing the timing capacitor to charge exponentially through the 1-megohm *sweep-speed multiplier* control, approaching the voltage at the cathode of regulator tube V_{10} . This voltage is adjusted by the *sweep-speed* control in the grid circuit of the regulator tube. The timing capacitor is charged from a constant voltage supply having a low impedance to ensure sweep-speed accuracy. Sweep linearity is enhanced by using only 10 percent or less of the charging voltage. The linear sweep voltage is taken from the plate of the sweep generator, clamped and impressed on the following sweep amplifier.

When the multivibrator trigger pulse ends, the grid of the sweep generator tube returns to a positive potential and the heavy plate current reduces the plate voltage of V_{11} to near zero, discharging the timing

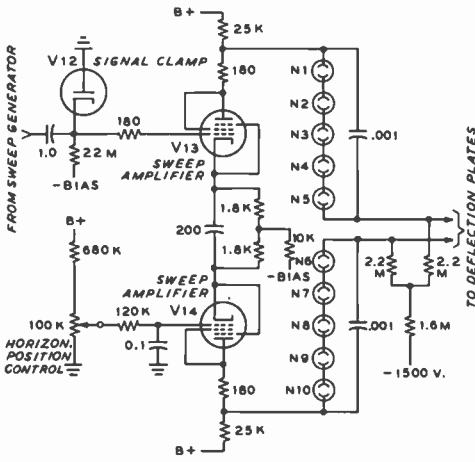

Figure 6

SWEEP AMPLIFIER

Cathode-coupled sweep amplifier provides balanced push-pull signal to deflection plates of cathode-ray tube. Two groups of neon glow lamps pass sweep signal but move average signal potential close to ground by virtue of constant voltage drop across lamps. Ionizing voltage for glow lamps is taken from high-voltage cathode-ray tube power supply.

capacitor and leaving it ready to receive the next sweep pulse from the multivibrator.

The Sweep Amplifier Since the amplitude of the sweep waveform at the output of the sweep generator is not large enough to drive the horizontal deflection plates of the cathode-ray tube, further amplification is needed. The signal from the sweep amplifier is impressed on the grid of a cathode-coupled sweep amplifier (V₁₃, V₁₁, figure 6) which inverts the phase and operates as a push-pull stage. Balanced sweep voltage is necessary to maintain the average potential of the deflection plates constant over the entire sweep to prevent defocussing. The horizontal position control varies the bias on one amplifier tube and thus determines the position from which the sweep starts. To ensure that the sweep will always start at the same position on the screen each time (for a given setting of the position control) a diode clamp (V₁₂) is placed between the grid of the opposite amplifier tube and ground to remove any charge that the input coupling capacitor may have gained during the previous sweep cycle.

To achieve proper focus on the screen of the cathode-ray tube it is necessary that the final anode and both pairs of deflection plates have approximately the same average potential. Since it is necessary to have the vertical deflection plates at ground potential so a direct connection may be made if desired, the average potential of the horizontal plates must also be near ground. The mean potential of the sweep amplifier plate circuit is about +250 volts. This is moved down to ground by means of the groups of neon glow lamps (N₁—N₁₀) which produce a constant voltage drop. A steady current of about 200 microamperes keeps the lamps ionized so that any change in plate potential of the sweep amplifier tubes (such as caused by signals) appears on the deflection plates unchanged in amplitude, but moved down in potential about 250 volts. The ionizing current is obtained from the -1500 volt cathode-ray tube power supply through a high-resistance network. Since the impedance of the neon glow lamps is rather high at frequencies involving the faster sweeps, small capacitors are shunted across the lamps to pass these frequencies.

The Power Supply The low-voltage power supply provides positive and negative regulated voltages for the various stages of the oscilloscope. The accelerating potential for the cathode-ray tube is obtained from an oscillator operating from the low-voltage supply (figure 7). The oscillator is a conventional Hartley circuit, with a high-voltage secondary winding on the oscillator transformer which supplies about 1200 volts rms to the rectifier tubes. Filament voltages for these tubes are also obtained from windings on the oscillator transformer. The frequency of oscillation is about 2000 Hertz.

8-2 Display of Waveforms

Together with a working knowledge of the controls of the oscilloscope, an understanding of how the patterns are traced on the screen must be obtained for a thorough knowledge of oscilloscope operation. With this in mind a careful analysis of two fundamental waveform patterns is discussed under the following headings:

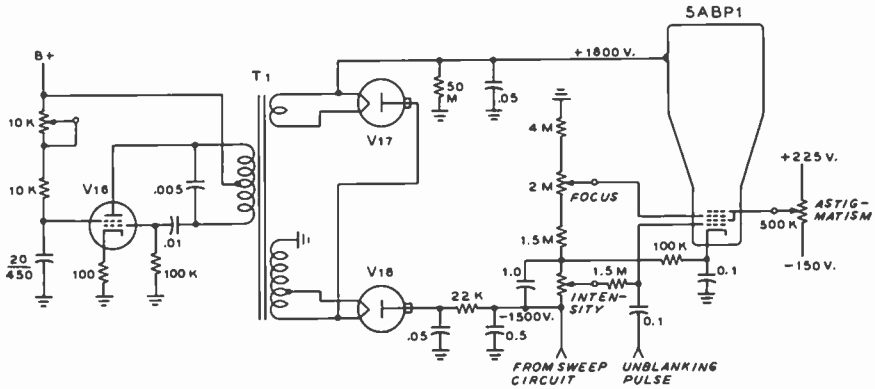

Figure 7

CATHODE-RAY TUBE POWER SUPPLY

Accelerating potential for CRT is derived from a 2-kHz oscillator working from the low-voltage supply. A high-voltage secondary winding on the oscillator transformer provides about 1200 volts rms which is rectified to provide -1500 volts and +1800 volts. Sum of two voltages (3300 volts) is applied to cathode-ray tube.

1. Patterns plotted against time (using the sweep generator for horizontal deflection).
2. Lissajous figures (using a sine wave for horizontal deflection).

Patterns Plotted Against Time A sine wave is typical of such a pattern and is convenient for this study. This

wave is amplified by the vertical amplifier and impressed on the vertical (Y-axis) deflection plates of the cathode-ray tube. Simultaneously the sawtooth wave from the time-base generator is amplified and impressed on the horizontal (X-axis) deflection plates.

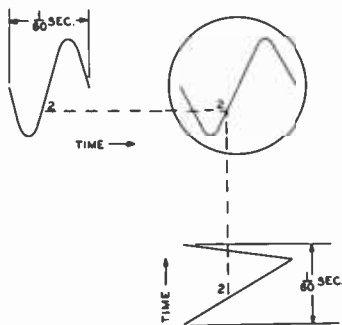

Figure 8

PROJECTION DRAWING OF A SINE WAVE APPLIED TO THE VERTICAL AXIS AND A SAWTOOTH WAVE OF THE SAME FREQUENCY APPLIED SIMULTANEOUSLY ON THE HORIZONTAL AXIS

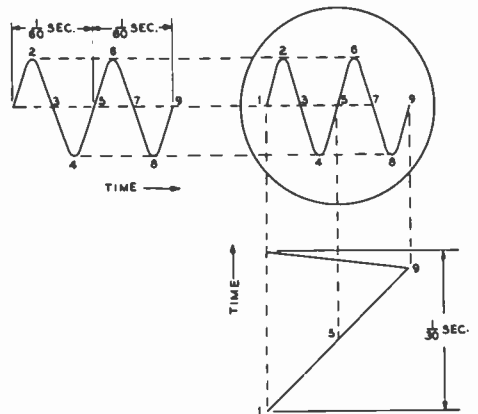

Figure 9

PROJECTION DRAWING SHOWING THE RESULTANT PATTERN WHEN THE FREQUENCY OF THE SAWTOOTH IS ONE-HALF OF THAT EMPLOYED IN FIGURE 8

The electron beam moves in accordance with the resultant of the sine and sawtooth signals. The effect is shown in figure 8 where the sine and sawtooth waves are graphically represented on time and voltage axes. Points on the two waves that occur simultaneously are numbered similarly. For example, point 2 on the sine wave and point 2 on the sawtooth wave occur at the same instant. Therefore the position of the beam at instant 2 is the resultant of the voltages on the horizontal and vertical deflection plates at instant 2. Referring to figure 8, by projecting lines from the two point-2 positions, the position of the electron beam at instant 2 can be located. If projections were drawn from every other instantaneous position of each wave to intersect on the circle representing the tube screen, the intersections of similarly timed projects would trace out a sine wave.

In summation, figure 8 illustrates the principles involved in producing a sine-wave trace on the screen of a cathode-ray tube. Each intersection of similarly timed projections represents the position of the electron beam acting under the influence of the varying voltage waveforms on each pair of deflection plates. Figure 9 shows the effect on the pattern of decreasing the frequency of the sawtooth wave. Any recurrent wave-

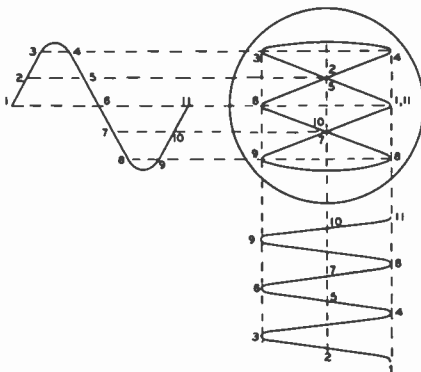

Figure 10

PROJECTION DRAWING SHOWING THE RESULTANT LISSAJOUS PATTERN WHEN A SINE WAVE APPLIED TO THE HORIZONTAL AXIS IS THREE TIMES THAT APPLIED TO THE VERTICAL AXIS

form plotted against time can be displayed and analyzed by the same procedure as used in these examples.

The sine-wave problem just illustrated is typical of the method by which any waveform can be displayed on the screen of the cathode-ray tube. Such waveforms as square wave, sawtooth wave, and many more irregular recurrent waveforms can be observed by the same method explained in the preceding paragraphs.

8-3 Lissajous Figures

Another fundamental pattern is the *Lissajous figures*, named after the 19th-century French scientist. This type of pattern is of particular use in determining the frequency ratio between two sine-wave signals. If one of these signals is known, the other can be easily calculated from the pattern made by the two signals on the screen of the cathode-ray tube. Common practice is to connect the known signal to the horizontal channel and the unknown signal to the vertical channel.

The presentation of Lissajous figures can be analyzed by the same method as previously used for sine-wave presentation. A simple example is shown in figure 10. The frequency ratio of the signal on the horizontal axis to the signal on the vertical axis is 3 to 1. If the known signal on the horizontal axis is 180 Hertz, the signal on the vertical axis is 60 Hertz.

Obtaining a Lissajous Pattern on the Screen; Oscilloscope Settings 1. The horizontal amplifier should be disconnected from the sweep oscillator. The signal to be examined should be connected to the horizontal amplifier of the oscilloscope.

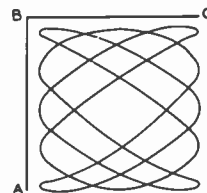

Figure 11

METHOD OF CALCULATING FREQUENCY RATIO OF LISSAJOUS FIGURES

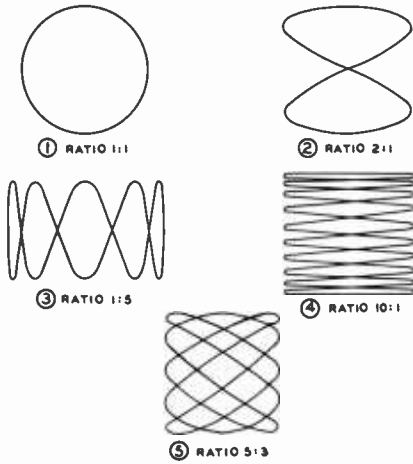

Figure 12

OTHER LISSAJOUS PATTERNS

2. An audio oscillator signal should be connected to the vertical amplifier of the oscilloscope.

3. By adjusting the frequency of the audio oscillator a stationary pattern should be obtained on the screen of the oscilloscope. It is not necessary to stop the pattern, but merely to slow it up enough to count the loops at the side of the pattern.

4. Count the number of loops which intersect an imaginary vertical line *AB* and the number of loops which intersect the imaginary horizontal line *BC* as shown in

figure 11. The ratio of the number of loops which intersect *AB* is to the number of loops which intersect *BC* as the frequency of the horizontal signal is to the frequency of the vertical signal.

Figure 12 shows other examples of Lissajous figures. In each case the frequency ratio shown is the frequency ratio of the signal on the horizontal axis to that on the vertical axis.

Phase Difference Patterns Coming under the heading of Lissajous figures is the method used to determine the phase difference between signals of the same frequency. The patterns involved take on the form of ellipses with different degrees of eccentricity.

The following steps should be taken to obtain a phase-difference pattern:

1. With no signal input to the oscilloscope, the spot should be centered on the screen of the tube.
2. Connect one signal to the vertical amplifier of the oscilloscope, and the other signal to the horizontal amplifier.
3. Connect a common ground between the two frequencies under investigation and the oscilloscope.
4. Adjust the vertical amplifier gain so as to give about 3 inches of deflection on a 5-inch tube, and adjust the calibrated scale of the oscilloscope so that

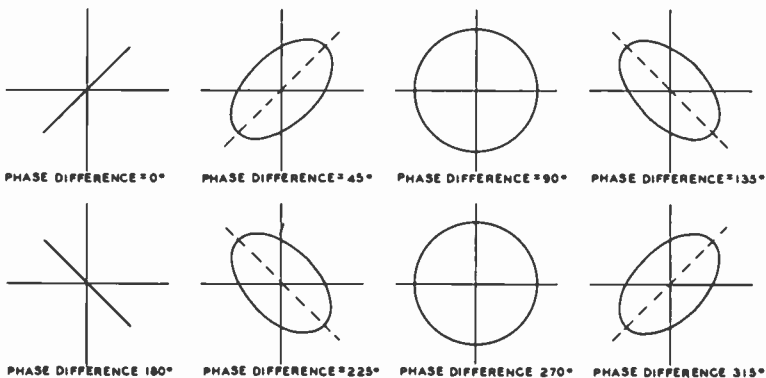

Figure 13

LISSAJOUS PATTERNS OBTAINED FROM THE MAJOR PHASE DIFFERENCE ANGLES

the vertical axis of the scale coincides precisely with the vertical deflection of the spot.

5. Remove the signal from the vertical amplifier, being careful not to change the setting of the vertical gain control.
6. Increase the gain of the horizontal amplifier to give a deflection exactly the same as that to which the vertical amplifier control is adjusted (3 inches). Reconnect the signal to the vertical amplifier.

The resulting pattern will give an accurate picture of the exact phase difference between the two waves. If these two patterns are exactly the same frequency but different in phase and maintain that difference, the pattern on the screen will remain stationary. If, however, one of these frequencies is drifting slightly, the pattern will drift slowly through 360° . The phase angles of 0° , 45° , 90° , 135° , 180° , 225° , 270° , and 315° are shown in figure 13.

Each of the eight patterns in figure 13 can be analyzed separately by the previously used projection method. Figure 14 shows two sine waves which differ in phase being projected on to the screen of the cathode-ray tube. These signals represent a phase difference of 45° . It is extremely important that (1) the spot has been centered on the screen of the cathode-ray tube, (2) that both the horizontal and vertical amplifiers have been adjusted to give exactly the same gain, and

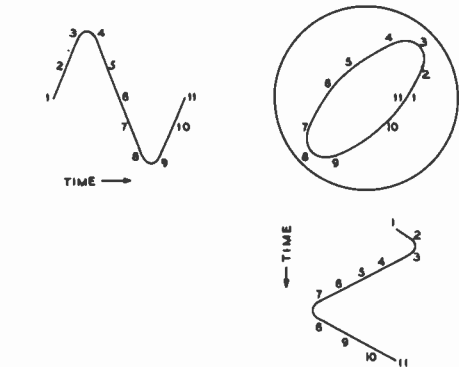

Figure 14

PROJECTION DRAWING SHOWING THE RESULTANT PHASE-DIFFERENCE PATTERN OF TWO SINE WAVES 45° OUT OF PHASE

(3) that the calibrated scale be originally set to coincide with the displacement of the signal along the vertical axis. If the amplifiers of the oscilloscope are not used for conveying the signal to the deflection plates of the cathode-ray tube, the coarse frequency switch should be set to *horizontal input direct* and the vertical input switch to *direct* and the outputs of the two signals must be adjusted to result in exactly the same vertical deflection as horizontal deflection. Once this deflection has been set by either the oscillator output controls or the amplifier

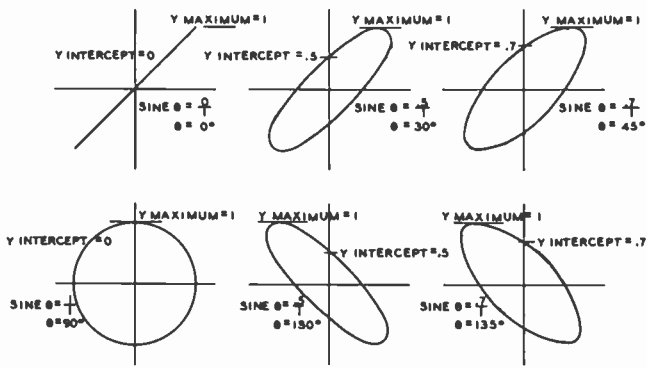

Figure 15

EXAMPLES SHOWING THE USE OF THE INTERCEPT FORMULA FOR DETERMINATION OF PHASE DIFFERENCE

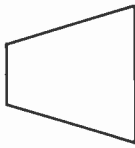

Figure 16
TRAPEZOIDAL MODULATION PATTERN

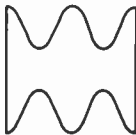

Figure 17
MODULATED CARRIER-WAVE PATTERN

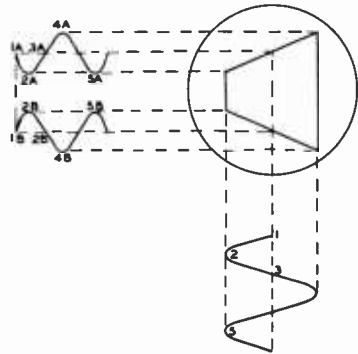

Figure 18
PROJECTION DRAWING SHOWING TRAPEZOIDAL PATTERN

gain controls in the oscillograph, it should not be changed for the duration of the measurement.

Determination of the Phase Angle The relation commonly used in determining the phase angle between signals is:

$$\text{Sine } \theta = \frac{Y \text{ intercept}}{Y \text{ maximum}}$$

where,

- θ equals phase angle between signals,
- Y intercept equals point where ellipse crosses vertical axis measured in tenths of inches (calibrations on the calibrated screen),
- Y maximum equals highest vertical point on ellipse in tenths of inches.

Several examples of the use of the formula are given in figure 15. In each case the Y intercept and Y maximum are indicated together with the sine of the angle and the angle itself. For the operator to observe these various patterns with a single signal source such as the test signal, there are many types of phase shifters which can be used. Circuits can be obtained from a number of radio textbooks. The procedure is to connect the original signal to the horizontal channel of the oscilloscope and the signal which has passed through the phase shifter to the verti-

cal channel of the oscilloscope, and follow the procedure set forth in this discussion to observe the various phase-shift patterns.

8-4 Monitoring Transmitter Performance with the Oscilloscope

The oscilloscope may be used as an aid for the proper operation of an a-m transmitter, and may be used as an indicator of the overall performance of the transmitter output signal, and as a modulation monitor.

Waveforms There are two types of patterns that can serve as indicators, the *trapezoidal pattern* (figure 16) and the *modulated-wave pattern* (figure 17). The trapezoidal pattern is presented on the screen by impressing a modulated carrier-wave signal on the vertical deflection plates and the signal that modulates the carrier-wave signal (the modulating signal) on the horizontal deflection plates. The trapezoidal pattern can be analyzed by the method used previously in analyzing waveforms. Figure 18 shows how the signals cause the electron beam to trace out the pattern.

The modulated-wave pattern is accomplished by presenting a modulated carrier wave on the vertical deflection plates and by using the time-base generator for horizontal

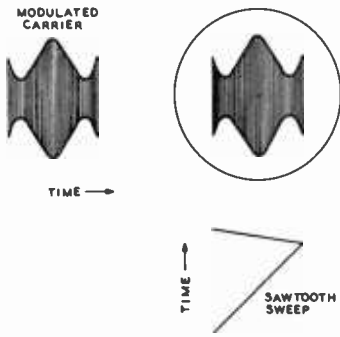

Figure 19

PROJECTION DRAWING SHOWING MODULATED-CARRIER WAVE PATTERN

deflection. The modulated-wave pattern also can be used for analyzing waveforms. Figure 19 shows how the two signals cause the electron beam to trace out the pattern.

The Trapezoidal Pattern The oscilloscope connections for obtaining a trapezoidal pattern are shown in figure 20. A portion of the audio output of the transmitter modulator is applied to the horizontal input of the oscilloscope. The vertical amplifier of the oscilloscope is disconnected, and a small amount of modulated r-f energy is coupled directly to the vertical deflection plates of the oscilloscope. A small pickup loop, loosely coupled to the final amplifier tank circuit and connected to the vertical deflection plates by a short length of coaxial line will suffice. The amount of excitation to the plates of the oscilloscope may be adjusted to provide a pattern of convenient size. On modulation of the transmitter, the trapezoidal pattern will appear. By changing the degree of modulation of the carrier wave the shape of the pattern will change. Figures 21 and 22 show the trapezoidal pattern for various degrees of modulation. The percentage of modulation may be determined by the following formula:

$$\text{Modulation percentage} = \frac{E_{\max} - E_{\min}}{E_{\max} + E_{\min}} \times 100$$

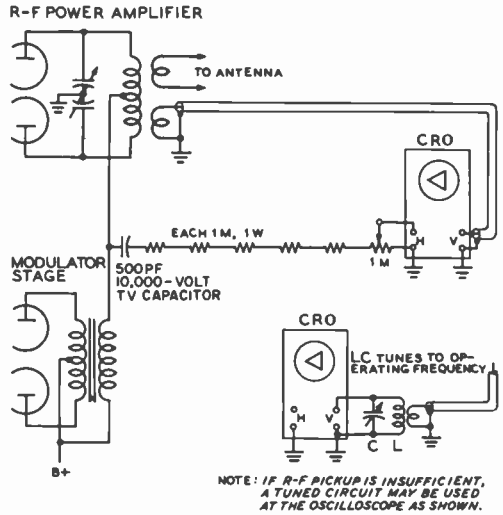

Figure 20

MONITORING CIRCUIT FOR TRAPEZOIDAL MODULATION PATTERN

where,

E_{\max} and E_{\min} are defined as in figure 21. An overmodulated signal is shown in figure 23.

The Modulated-Wave Pattern The oscilloscope connections for obtaining a modulated-wave pattern are shown in figure 24. The internal sweep circuit of the oscilloscope is applied to the horizontal plates, and the modulated r-f signal is applied to the vertical plates, as described before. If desired, the internal sweep circuit may be synchronized with the modulating signal of the transmitter by applying a small portion of the modulator output signal to the *external sync* post of the oscilloscope. The percentage of modulation may be determined in the same fashion as with a trapezoidal pattern. Figures 25, 26, and 27 show the modulated-wave pattern for various degrees of modulation.

8-5 Receiver I-F Alignment with an Oscilloscope

The alignment of the i-f amplifiers of a receiver consists of adjusting all the tuned circuits to resonance at the intermediate fre-

TRAPEZOIDAL PATTERNS

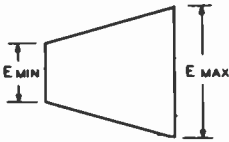

Figure 21

LESS THAN 100% MODULATION

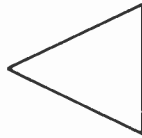

Figure 22

100% MODULATION

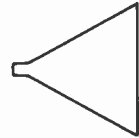

Figure 23

OVERMODULATION

quency and at the same time permitting passage of a predetermined number of sidebands. The best indication of this adjustment is a resonance curve representing the response of the i-f circuit to its particular range of frequencies.

As a rule medium- and low-priced receivers use i-f transformers whose bandwidth is about 5 kHz on each side of the fundamental frequency. The response curve of these i-f transformers is shown in figure 28. High-fidelity receivers usually contain i-f transformers which have a broader bandwidth which is usually 10 kHz on each side of the fundamental. The response curve for this type transformer is shown in figure 29.

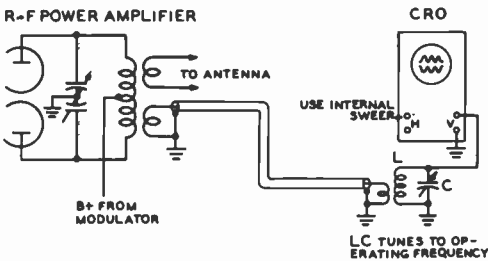

Figure 24

MONITORING CIRCUIT FOR MODULATED-WAVE PATTERN

Resonance curves such as these can be displayed on the screen of an oscilloscope. For a complete understanding of the procedure it is important to know how the resonance curve is traced.

The Resonance Curve on the Screen To present a resonance curve on the screen, a frequency-modulated signal source must be available. This signal source is a signal generator whose output is the fundamental i-f frequency which is frequency-modulated 5 to 10 kHz each side of

CARRIER-WAVE PATTERN

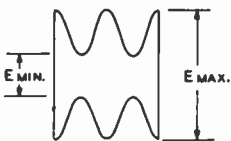

Figure 25

LESS THAN 100% MODULATION

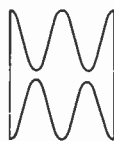

Figure 26

100% MODULATION

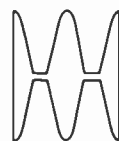

Figure 27

OVERMODULATION

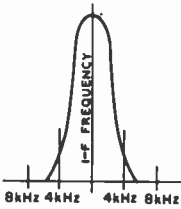

Figure 28

I-F FREQUENCY RESPONSE CURVE OF A LOW PRICED RECEIVER

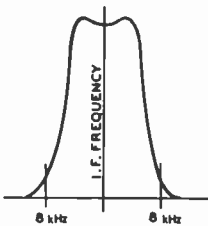

Figure 29

FREQUENCY RESPONSE OF HIGH-FIDELITY I-F SYSTEM

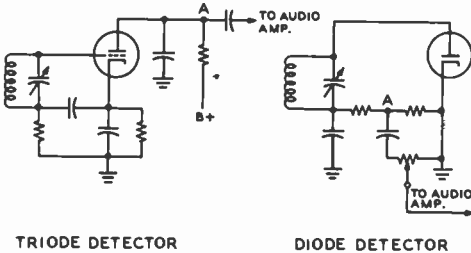

Figure 30

CONNECTION OF THE OSCILLOSCOPE ACROSS THE DETECTOR LOAD

the fundamental frequency. A signal generator of this type generally takes the form of an ordinary signal generator with a rotating motor-driven tuned-circuit capacitor, called a *wobbulator*, or its electronic equivalent, which is a reactance tube.

The method of presenting a resonance curve on the screen is to connect the vertical channel of the oscilloscope across the detector load of the receiver as shown in the

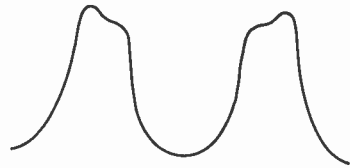

Figure 31

DOUBLE-RESONANCE CURVE

detectors of figure 30 (between point A and ground) and the time-base generator output to the horizontal channel. In this way the d-c voltage across the detector load varies with the frequencies which are passed by the i-f system. Thus, if the time-base generator is set at the frequency of rotation of the motor-driven capacitor, or the reactance tube, a pattern resembling figure 31 (a double resonance curve) appears on the screen.

Figure 31 is explained by considering figure 32. In half a rotation of the motor-driven capacitor the frequency increases from 445 kHz to 465 kHz, more than covering the range of frequencies passed by the i-f system. Therefore, a full resonance curve is presented on the screen during this half rotation since only *half* a cycle of the voltage producing horizontal deflection has transpired. In the second half of the rotation the motor-driven capacitor takes the frequency of the signal in the reverse order through the range of frequencies passed by the i-f system. In this interval the time-base generator sawtooth waveform completes its cycle, drawing the electron beam further across the screen and then returning it to the starting point. Subsequent cycles of the motor-driven capacitor and the sawtooth voltage merely retrace the same pattern. Since the signal being viewed is applied through the vertical amplifier, the sweep can be synchronized internally.

Some signal generators, particularly those employing a reactance tube, provide a sweep output in the form of a sine wave which is synchronized to the frequency with which the reactance tube is swinging the fundamental frequency through its limits, (usually 60 hertz). If such a signal is used for horizontal deflection, it is already synchronized.

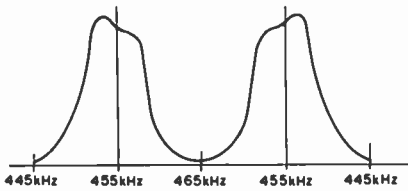

Figure 32

DOUBLE-RESONANCE ACHIEVED BY COMPLETE ROTATION OF THE MOTOR-DRIVEN CAPACITOR



Figure 33

SUPERPOSITION OF RESONANCE CURVES

Since this signal is a sine wave, the response curve is observed as it sweeps the spot across the screen from left to right; and it is observed again as the sine wave sweeps the spot back again from right to left. Under these conditions the two response curves are superimposed on each other and the high-frequency responses of both curves are at one end and the low-frequency response of both curves is at the other end. The i-f trimmer capacitors are adjusted to produce a response curve which is symmetrical on each side of the fundamental frequency.

When using sawtooth sweep, the two response curves can also be superimposed. If the sawtooth signal is generated at exactly twice the frequency of rotation of the motor-driven capacitor, the two resonance curves will be superimposed (figure 33) if the i-f transformers are properly tuned. If the two curves do not coincide the i-f trimmer capacitors should be adjusted. At the point of coincidence the tuning is correct. It should be pointed out that rarely do the two curves agree perfectly. As a result, optimum adjustment is made by making the peaks coincide. This latter procedure is the one generally used in i-f adjustment. When the

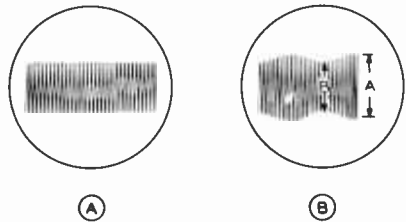

Figure 34

SINGLE-TONE PRESENTATION

Oscilloscope trace of SSB signal modulated by single tone (A). Incomplete carrier suppression or spurious products will show modulated envelope of (B). The ratio of suppression is:

$$S = 20 \log \frac{A+B}{A-B}$$

two curves coincide, it is evident that the i-f system responds equally to signals higher and lower than the fundamental i-f frequency.

8-6 Single-Sideband Applications

Measurement of power output and distortion are of particular importance in SSB transmitter adjustment. These measurements are related to the extent that distortion rises rapidly when the power amplifier is overloaded. The usable power output of an SSB transmitter is often defined as the maximum peak envelope power obtainable with a specified *signal-to-distortion* ratio. The oscilloscope is a useful instrument for measuring and studying distortion of all types that may be generated in single-sideband equipment.

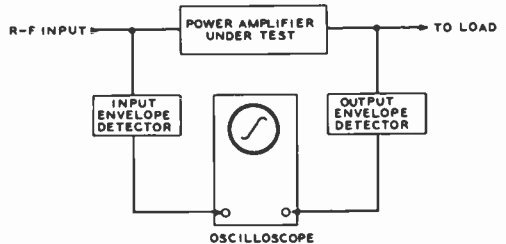

Figure 35

BLOCK DIAGRAM OF LINEARITY TRACER

Single-Tone Observations When an SSB transmitter is modulated with a single audio tone, the r-f output should be a single radio frequency. If the vertical plates of the oscilloscope are coupled to the output of the transmitter, and the horizontal amplifier sweep is set to a slow rate, the scope presentation will be as shown in figure 34. If unwanted distortion products or carrier are present, the top and bottom of the pattern will develop a "ripple" proportional to the degree of spurious products.

The Linearity Tracer The *linearity tracer* is an auxiliary detector to be used with an oscilloscope for quick observation of amplifier adjustments and parameter variations. This instrument consists of two SSB *envelope detectors* the outputs of which connect to the horizontal and vertical inputs of an oscilloscope. Figure 35 shows a block diagram of a typical linearity test setup. A two-tone test signal is normally employed to supply an SSB modulation envelope, but any modulating signal that provides an envelope that varies from zero to full amplitude may be used. Speech modulation gives a satisfactory trace, so that this instrument may be used as a visual monitor of transmitter linearity. It is particularly useful for monitoring the signal level and clearly shows when the amplifier under observation is overloaded. The linearity trace will be a straight line regardless of the envelope shape if the amplifier has no distortion. Overloading causes a sharp break in the linearity curve. Distortion due to too much bias is also easily observed and the adjustment for low distortion can easily be made.

Another feature of the linearity detector is that the distortion of each individual stage can be observed. This is helpful in troubleshooting. By connecting the input envelope detector to the output of the SSB generator, the over-all distortion of the entire r-f circuit beyond this point is observed. The unit can also serve as a voltage indicator which is useful in making tuning adjustments.

The circuit of a typical envelope detector is shown in figure 36. Two matched germanium diodes are used as detectors. The detectors are not linear at low signal levels, but if the nonlinearity of the two detectors is matched, the effect of their nonlinearity on

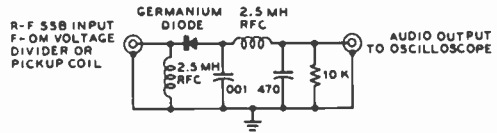

Figure 36

SCHEMATIC OF ENVELOPE DETECTOR

the oscilloscope trace is cancelled. The effect of diode differences is minimized by using a diode load of 5000 to 10,000 ohms, as shown. It is important that both detectors operate at approximately the same signal level so that their differences will cancel more exactly. The operating level should be 1 volt or higher.

It is convenient to build the detector in a small shielded enclosure such as an i-f transformer can fitted with coaxial input and output connectors. Voltage dividers can be similarly constructed so that it is easy to insert the desired amount of voltage attenuation from the various sources. In some cases it is convenient to use a pickup loop on the end of a short length of coaxial cable.

The phase shift of the amplifiers in the oscilloscope should be the same and their frequency response should be flat out to at least twenty times the frequency difference of the two test tones. Excellent high-frequency characteristics are necessary because the rectified SSB envelope contains harmonics extending to the limit of the envelope detector's response. Inadequate frequency response of the vertical amplifier may cause a little "foot" to appear on the lower end of the trace, as shown in figure 37. If it is small, it may be safely neglected.

Another spurious effect often encountered is a double trace, as shown in figure 38. This can usually be corrected with an RC network placed between one detector and the oscilloscope. The best method of testing the detectors and the amplifiers is to connect the input of the envelope detectors in parallel. A perfectly straight line trace will result when everything is working properly. One detector is then connected to the other r-f source through a voltage divider adjusted so that no appreciable change in the setting of

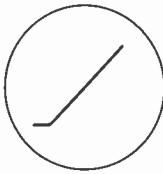

Figure 37

EFFECT OF INADEQUATE RESPONSE OF VERTICAL AMPLIFIER



Figure 38

DOUBLE TRACE CAUSED BY PHASE SHIFT

the oscilloscope amplifier controls is required. Figure 39 illustrates some typical linearity traces. *Trace A* is caused by inadequate static plate current in class-A or class-B amplifiers or a mixer stage. To regain linearity, the grid bias of the stage should be reduced, the screen voltage should be raised, or the signal level should be decreased. *Trace B* is a result of poor grid-circuit regulation when grid current is drawn, or a result of

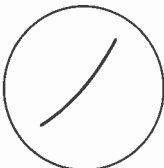

(A)



(B)

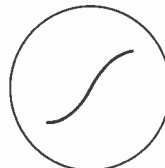

(C)



(D)

Figure 39

TYPICAL LINEARITY TRACES

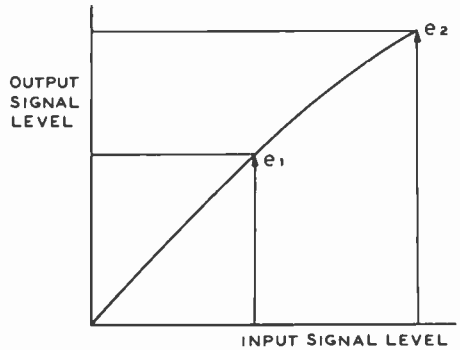

Figure 40

ORDINATES ON LINEARITY CURVE FOR 3RD-ORDER DISTORTION EQUATION

nonlinear plate characteristics of the amplifier tube at large plate swings. More grid swamping should be used, or the exciting signal should be reduced. A combination of the effects of A and B are shown in *Trace C*. *Trace D* illustrates amplifier overloading. The exciting signal should be reduced.

A means of estimating the distortion level observed is quite useful. The first- and third-order distortion components may be derived by an equation that will give the approximate signal-to-distortion level ratio of a *two-tone* test signal, operating on a given linearity curve. Figure 40 shows a linearity curve with two ordinates erected at half and full peak input signal level. The length of the ordinates e_1 and e_2 may be scaled and used in the following equation:

Signal-to-distortion ratio in db =

$$20 \log \frac{3 e_1 - e_2}{2 e_1 - e_2}$$

Special Circuitry for Vacuum Tubes and Semiconductors

A whole new concept of vacuum-tube and semiconductor applications has been developed in recent years. No longer are these devices chained to the field of radio or wire communication. This chapter is devoted to some of the more common circuits encountered in computer technology and in industrial and military applications.

While the circuits shown are mainly vacuum-tube configurations, they have their counterparts in semiconductor technology.

9-1 Limiting Circuits

The term *limiting* refers to the removal or suppression, by electronic means, of the extremities of an electronic signal. Circuits which perform this function are referred to as *limiters* or *clippers*. Limiters are useful in waveshaping circuits where it is desirable to square off the extremities of the applied signal. A sine wave may be applied to a limiter circuit to produce a rectangular wave. A peaked wave may be applied to a limiter circuit to eliminate either the positive or negative peaks from the output. Limiter circuits are employed in f-m receivers where it is necessary to limit the amplitude of the signal applied to the detector. Limiters may be used to reduce automobile ignition noise in short-wave receivers, or to maintain a high average level of modulation in a transmitter. They may also be used as protective devices to limit input signals to special circuits.

Diode Limiters The characteristics of a diode tube are such that the tube

conducts only when the plate is at a positive potential with respect to the cathode. A positive potential may be placed on the cathode, but the tube will not conduct until the voltage on the plate rises above an equally positive value. As the plate becomes more positive with respect to the cathode, the diode conducts and passes that portion of the wave which is more positive than the cathode voltage. Diodes may be used as either series or parallel limiters, as shown in figure 1. A diode may be so biased that only a certain portion of the positive or negative cycle is removed.

Audio Peak Limiting An audio peak clipper consisting of two diode limiters may be used to limit the amplitude of an audio signal to a predetermined value to provide a high average level of modulation without danger of overmodulation. An effective limiter for this service is the *series-diode gate clipper*. A circuit of this clipper is shown in figure 2. The audio signal to be clipped is coupled to the clipper through C_1 . R_1 and R_2 are the clipper input and output load resistors. The clipper plates are tied together and are connected to the clipping level control (R_4) through series resistor R_3 . R_4 acts as a voltage divider between the high-voltage supply and ground. The exact point at which clipping will occur is set by R_4 , which controls the positive potential applied to the diode plates.

Under static conditions, a d-c voltage is obtained from R_4 and applied through R_3 to both plates of the 6AL5 tube. Current

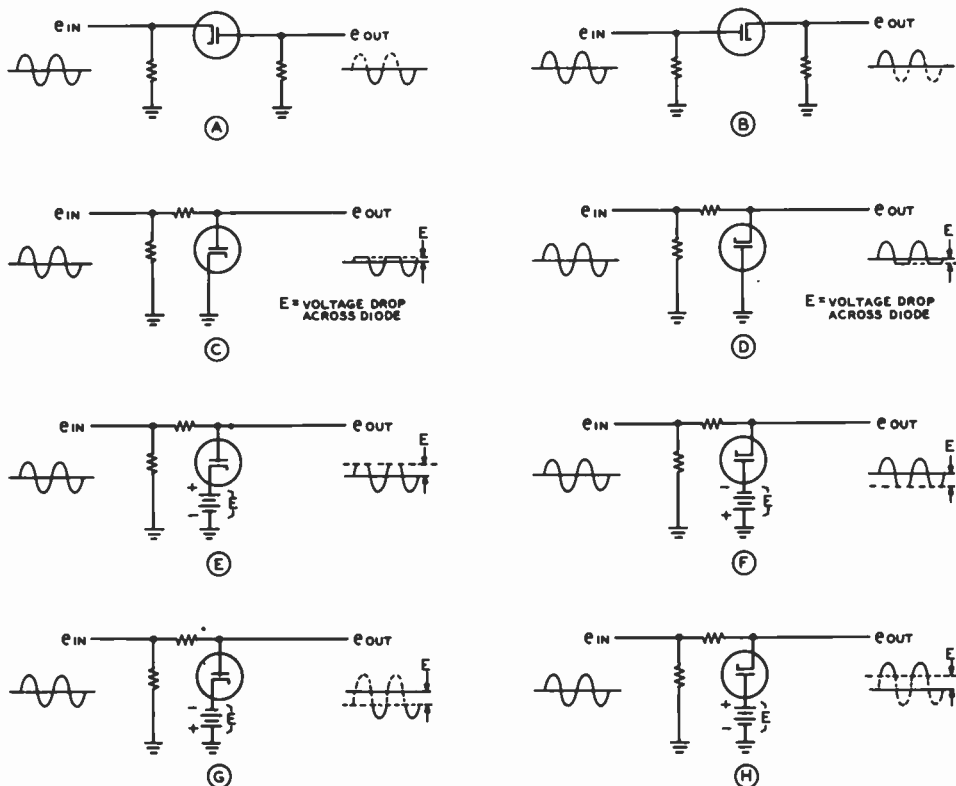

Figure 1

VARIOUS DIODE LIMITING CIRCUITS

Series diodes limiting positive and negative peaks are shown in A and B. Parallel diodes limiting positive and negative peaks are shown in C and D. Parallel diodes limiting above and below ground are shown in E and F. Parallel-diode limiters which pass negative and positive peaks are shown in G and H.

flows through R_4 , R_3 , and divides through the two diode sections of the 6AL5 and the two load resistors (R_1 and R_2). All parts of the clipper circuit are maintained at a positive potential above ground. The voltage drop between the plate and cathode of each diode is very small compared to the drop across the 300,000-ohm resistor (R_3) in series with the diode plates. The plate and cathode of each diode are therefore maintained at approximately equal potentials as long as there is plate-current flow. Clipping does not occur until the peak audio-input voltage reaches a value greater than the static voltages at the plates of the diode.

Assume that R_4 has been set to a point that will give 4 volts at the plates of the 6AL5. When the peak audio-input voltage

is less than 4 volts, both halves of the tube conduct at all times. As long as the tube conducts, its resistance is very low compared with plate resistor R_3 . Whenever a voltage change occurs across input resistor R_1 , the voltage at all of the tube elements increases or decreases by the same amount as the input voltage changes, and the voltage drop across R_3 changes by an equal amount. As long as the peak input voltage is less than 4 volts, the 6AL5 acts merely as a conductor, and the output cathode is permitted to follow all voltage changes at the input cathode.

If, under static conditions, 4 volts appear at the diode plates, then twice this voltage (8 volts) will appear if one of the diode circuits is opened, thus removing its d-c load from the circuit. As long as only one of the diodes

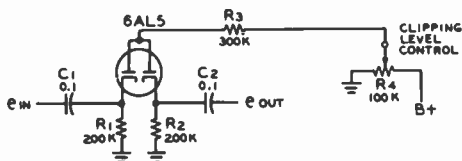

Figure 2

THE SERIES-DIODE GATE CLIPPER FOR AUDIO PEAK LIMITING

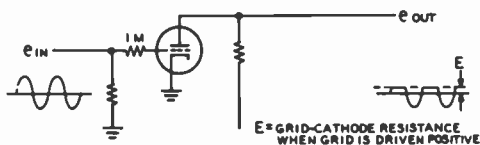

Figure 3

GRID LIMITING CIRCUIT

continues to conduct, the voltage at the diode plates cannot rise above twice the voltage selected by R_4 . In this example, the voltage cannot rise above 8 volts. Now, if the input audio voltage applied through C_1 is increased to any peak value between zero and + 4 volts, the first cathode of the 6AL5 will increase in voltage by the same amount to the proper value between 4 and 8 volts. The other tube elements will assume the same potential as the first cathode. However, the 6AL5 plates cannot increase more than 4 volts above their original 4-volt static level. When the input voltage to the first cathode of the 6AL5 increases to more than + 4 volts, the cathode potential increases to more than 8 volts. Since the plate circuit potential remains at 8 volts, the first diode section ceases to conduct until the input voltage across R_1 drops below 4 volts.

When the input voltage swings in a negative direction, it will subtract from the 4-volt drop across R_1 and decrease the voltage on the input cathode by an amount equal to the input voltage. The plates and the output cathode will follow the voltage level at the input cathode as long as the input voltage does not swing below - 4 volts. If the input voltage does not change more than 4 volts in a negative direction, the plates of the 6AL5 will also become negative. The

potential at the output cathode will follow the input cathode voltage and decrease from its normal value of 4 volts until it reaches zero potential. As the input cathode voltage decreases to less than zero, the plates will follow. However, the output cathode, grounded through R_2 , will stop at zero potential as the plate becomes negative. Conduction through the second diode is impossible under these conditions. The output cathode remains at zero potential until the voltage at the input cathode swings back to zero.

The voltage developed across output resistor R_2 follows the input voltage variations as long as the input voltage does not swing to a peak value greater than the static voltage at the diode plates, which is determined by R_1 . Effective clipping may thus be obtained at any desired level.

The square-topped audio waves generated by this clipper are high in harmonic content, but these higher-order harmonics may be greatly reduced by a low-level speech filter.

Grid Limiters A triode grid limiter is shown in figure 3. On positive peaks of the input signal, the triode grid attempts to swing positive, and the grid-cathode resistance drops to about 1000 ohms or so. The voltage drop across the series grid resistor

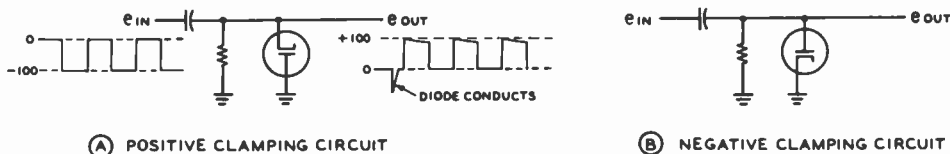

Figure 4

SIMPLE POSITIVE AND NEGATIVE CLAMPING CIRCUITS

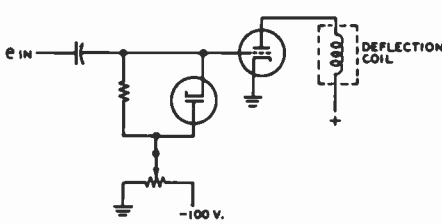

Figure 5

NEGATIVE CLAMPING CIRCUIT EMPLOYED IN ELECTROMAGNETIC SWEEP SYSTEM

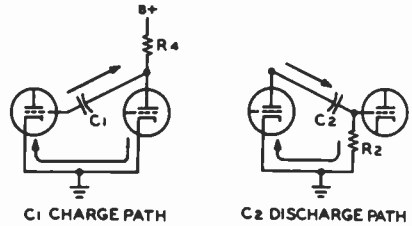

Figure 7

THE CHARGE AND DISCHARGE PATHS IN THE FREE-RUNNING MULTIVIBRATOR OF FIGURE 6

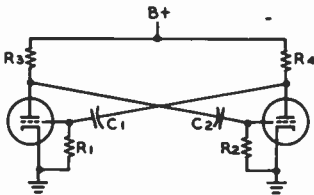

Figure 6

BASIC MULTIVIBRATOR CIRCUITS

(usually of the order of 1 megohm) is large compared to the grid-cathode drop, and the resulting limiting action removes the top part of the positive input wave.

or a *d-c restorer*. Clamping circuits are used after RC-coupling circuits where the waveform swing is required to be either above or below the reference voltage, instead of alternating on both sides of it (figure 4). Clamping circuits are usually encountered in oscilloscope sweep circuits. If the sweep voltage does not always start from the same reference point, the trace on the screen does not begin at the same point on the screen each time the sweep is repeated and therefore is "jittery." If a clamping circuit is placed between the sweep amplifier and the deflection element, the start of the sweep can be regulated by adjusting the d-c voltage applied to the clamping tube (figure 5).

9-2 Clamping Circuits

9-3 Multivibrators

A circuit which holds either amplitude extreme of a waveform to a given reference level of potential is called a *clamping circuit*

The *multivibrator*, or *relaxation oscillator*, is used for the generation of nonsinusoidal waveforms. The output is rich in harmonics,

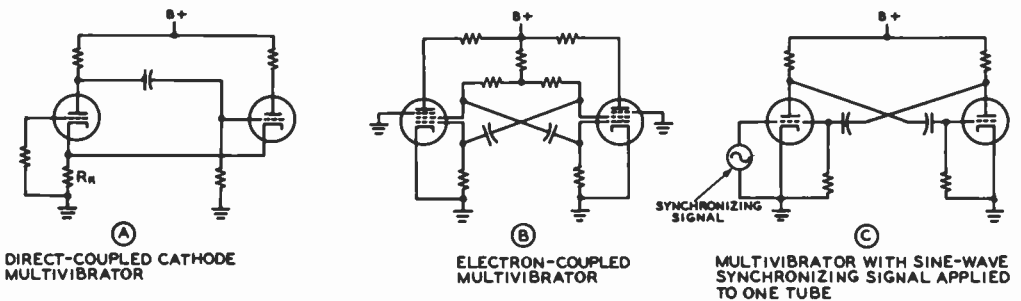

Figure 8

VARIOUS TYPES OF MULTIVIBRATOR CIRCUITS

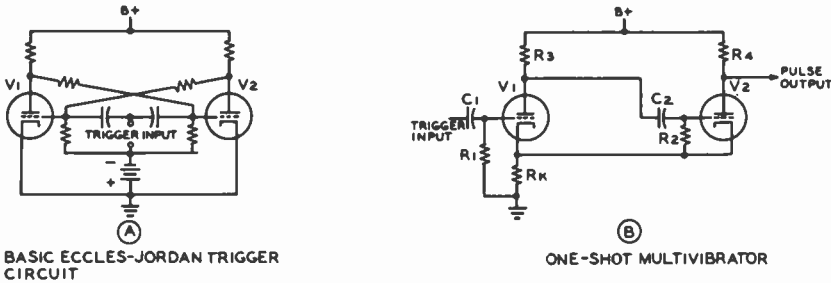

Figure 9

ECCLES-JORDAN MULTIVIBRATOR CIRCUITS

but the inherent frequency stability is poor. The multivibrator may be stabilized by the introduction of synchronizing voltages of harmonic or subharmonic frequency.

In its simplest form, the multivibrator is a simple two-stage RC-coupled amplifier with the output of the second stage coupled through a capacitor to the grid of the first tube, as shown in figure 6. Since the output of the second stage is of the proper polarity to reinforce the input signal applied to the first tube, oscillations can readily take place, started by thermal agitation and miscellaneous tube noise. Oscillation is maintained by the process of building up and discharging the store of energy in the grid-coupling capacitors of the two tubes. The charging and discharging paths are shown in figure 7. Various types of multivibrators are shown in figure 8.

The output of a multivibrator may be used as a source of square waves, as an electronic switch, or as a means of obtaining frequency division. Submultiple frequencies as low as one-tenth of the injected synchronizing frequency may easily be obtained.

The Eccles-Jordan Circuit

The Eccles-Jordan trigger circuit is shown in figure 9A. This is not a true multivibrator, but rather a circuit that possesses two conditions of stable equilibrium. One condition is when V_1 is conducting and V_2 is cutoff; the other when V_2 is conducting and V_1 is cutoff. The circuit remains in one or the other of these two stable conditions with no change in operating potentials until some external action occurs which causes the nonconducting tube to conduct. The tubes then reverse their functions and remain in the new condition as long as no plate current flows in the cut-off tube. This type of circuit is known as a *flip-flop* circuit.

Figure 9B illustrates a modified Eccles-Jordan circuit which accomplishes a complete cycle when triggered by a positive pulse. Such a circuit is called a *one-shot* multivibrator. For initial action, V_1 is cut off and V_2 is conducting. A large positive

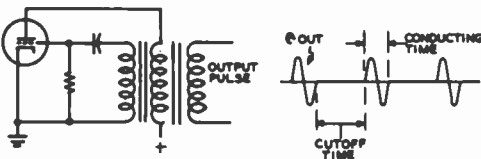

Figure 10

SINGLE-SWING BLOCKING OSCILLATOR

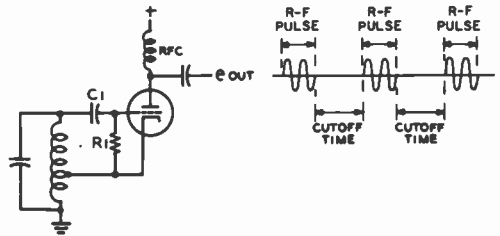

Figure 11

HARTLEY OSCILLATOR USED AS BLOCKING OSCILLATOR BY PROPER CHOICE OF R_1, C_1

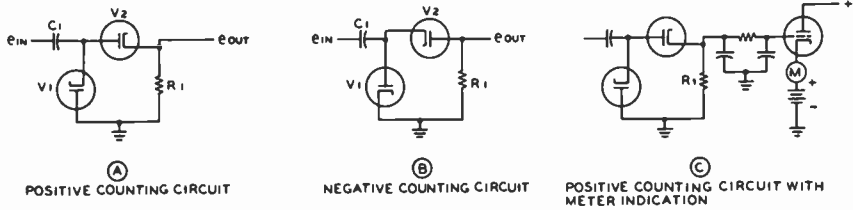

Figure 12

POSITIVE AND NEGATIVE COUNTING CIRCUITS

pulse applied to the grid of V_1 causes this tube to conduct, and the voltage at its plate decreases by virtue of the IR drop through R_3 . Capacitor C_2 is charged rapidly by this abrupt change in V_1 plate voltage, and V_2 becomes cut off while V_1 conducts. This condition exists until C_2 discharges, allowing V_2 to conduct, raising the cathode bias of V_1 until it is once again cut off.

A direct-cathode-coupled multivibrator is shown in figure 8A. R_K is a common cathode resistor for the two tubes, and coupling takes place across this resistor. It is impossible for a tube in this circuit to completely cut off the other tube, and a circuit of this type is called a *free-running* multivibrator in which the condition of one tube temporarily cuts off the other.

9-4 The Blocking Oscillator

A *blocking oscillator* is any oscillator which cuts itself off after one or more cycles caused by the accumulation of a negative charge on the grid capacitor. This negative charge may gradually be drained off through the grid resistor of the tube, allowing the circuit to oscillate once again. The process is repeated and the tube becomes an intermittent oscillator. The rate of such an oc-

currence is determined by the RC time constant of the grid circuit. A *single-swing blocking oscillator* is shown in figure 10, wherein the tube is cut off before the completion of one cycle. The tube produces single pulses of energy, the time between the pulses being regulated by the discharge time of the grid RC network. The *self-pulsing* blocking oscillator is shown in figure 11, and is used to produce pulses of r-f energy, the number of pulses being determined by the timing network in the grid circuit of the oscillator. The rate at which these pulses occur is known as the *pulse-repetition frequency*, or *p.r.f.*

9-5 Counting Circuits

A *counting circuit*, or *frequency divider*, is one which receives uniform pulses (representing units to be counted) and produces a voltage that is proportional to the frequency of the pulses. A counting circuit may be

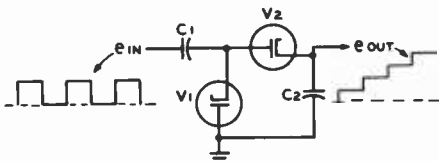

Figure 13

STEP-BY-STEP COUNTING CIRCUIT

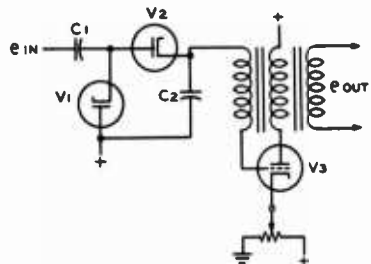

Figure 14

THE STEP-BY-STEP COUNTER USED TO TRIGGER A BLOCKING OSCILLATOR. THE BLOCKING OSCILLATOR SERVES AS A FREQUENCY DIVIDER.

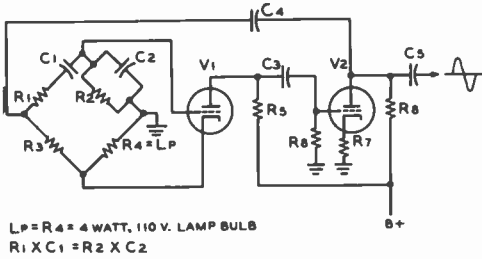

Figure 15

THE WIEN-BRIDGE AUDIO OSCILLATOR

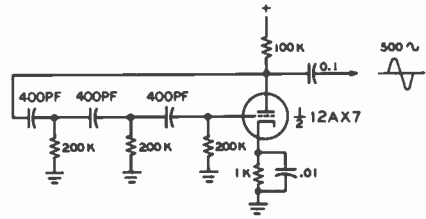

Figure 16

THE PHASE-SHIFT OSCILLATOR

used in conjunction with a blocking oscillator to produce a trigger pulse which is a submultiple of the frequency of the applied pulse. Either positive or negative pulses may be counted. A positive counting circuit is shown in figure 12A, and a negative counting circuit is shown in figure 12B. The positive counter allows a certain amount of current to flow through R₁ each time a pulse is applied to C₁.

The positive pulse charges C₁, and makes the plate of V₂ positive with respect to its cathode. V₂ conducts until the exciting pulse passes. C₁ is then discharged by V₁, and the circuit is ready to accept another pulse. The average current flowing through R₁ increases as the pulse-repetition frequency increases, and decreases as the p.r.f. decreases.

By reversing the diode connections, as shown in figure 12B, the circuit is made to respond to negative pulses. In this circuit, an increase in the p.r.f. causes a decrease in the average current flowing through R₁, which is opposite to the effect in the positive counter.

A *step-counter* is similar to the circuits discussed, except that a capacitor which is large compared to C₁ replaces the diode load resistor. The charge of this capacitor is increased during the time of each pulse, producing a step voltage across the output (figure 13). A blocking oscillator may be connected to a step counter, as shown in figure 14. The oscillator is triggered into operation when the voltage across C₂ reaches a point sufficiently positive to raise the grid of V₃ above cutoff. Circuit parameters may be chosen so that a count division up to 1/20 may be obtained with reliability.

9-6 Resistance-Capacitance Oscillators

In an *RC oscillator*, the frequency is determined by a resistance capacitance network that provides regenerative coupling between the output and input of a feedback amplifier. No use is made of a tank circuit consisting of inductance and capacitance to control the frequency of oscillation.

The *Wien-Bridge* oscillator employs a *Wien network* in the RC feedback circuit and is shown in figure 15. Tube V₁ is the oscillator tube, and tube V₂ is an amplifier and phase-inverter tube. Since the feedback voltage through C₁ produced by V₂ is in phase with the input circuit of V₁ at all frequencies, oscillation is maintained by voltages of any frequency that exist in the circuit. The bridge circuit is used, then, to eliminate feedback voltages of all frequencies except the single frequency desired at the output of the oscillator. The bridge allows a voltage of only one frequency to be effective in the circuit because of the degeneration and phase shift provided by this circuit. The frequency at which oscillation occurs is:

$$f = \frac{1}{2\pi R_1 C_1}$$

when,

$$R_1 \times C_1 \text{ equals } R_2 \times C_2$$

A lamp (L_p) is used for the cathode resistor of V₁ as a thermal stabilizer of the oscillator amplitude. The variation of the resistance with respect to the current of the lamp bulb holds the oscillator output voltage at a nearly constant amplitude.

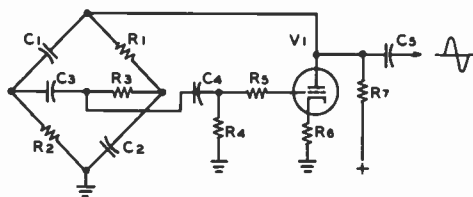

Figure 17

THE BRIDGE-TYPE PHASE-SHIFT OSCILLATOR

The *phase-shift oscillator* shown in figure 16 is a single-tube oscillator using a three-section phase-shift network. Each section of the network produces a phase shift in proportion to the frequency of the signal that passes through it. For oscillations to be produced, the signal from the plate of the tube must be shifted 180°. Three successive phase shifts of 60° accomplish this, and the frequency of oscillation is determined by this phase shift.

A high- μ triode or a pentode must be used in this circuit. In order to increase the frequency of oscillation, either the resistance or the capacitance must be decreased by an appropriate amount.

A *bridge-type phase-shift oscillator* is shown in figure 17. The bridge is so proportioned that only at one frequency is the phase shift through the bridge equal to 180°. Voltages of other frequencies are fed back to the grid of the tube out of phase with the existing grid signal, and are cancelled by being amplified out of phase.

The *Bridge-T oscillator* developed by the National Bureau of Standards consists of a two-stage amplifier having two feedback loops, as shown in figure 18. Loop 1 consists of a regenerative cathode-to-cathode loop, consisting of L_{p1} and C_3 . The bulb regulates the positive feedback, and tends to stabilize the output of the oscillator, much as in the manner of the Wien circuit. Loop 2 consists of a grid-cathode degenerative circuit, containing the Bridge-T.

Oscillation will occur at the null frequency of the bridge, at which frequency the bridge allows minimum degeneration in loop 2 (figure 19).

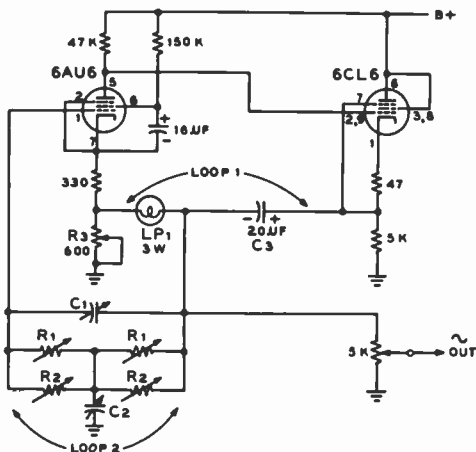

Figure 18

THE NBS BRIDGE-T OSCILLATOR CIRCUIT EMPLOYS TWO FEEDBACK LOOPS. LOOP 1 IS REGENERATIVE, LOOP 2 IS DEGENERATIVE

9-7 Feedback

Feedback amplifiers have been discussed in Chapter 6, section 15 of this Handbook. A more general use of feedback is in automatic control and regulating systems.

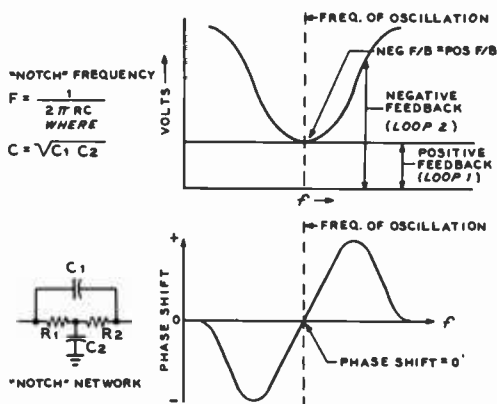

Figure 19

BRIDGE-T FEEDBACK LOOP CIRCUITS

Oscillation will occur at the null frequency of the bridge, at which frequency the bridge allows minimum degeneration in loop 2.

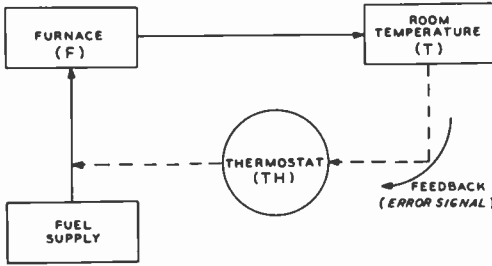

Figure 20

SIMPLE CLOSED-LOOP FEEDBACK SYSTEM

Room temperature (T) controls fuel supply to furnace (F) by feedback loop through thermostat (TH) control.

Mechanical feedback has been used for many years in such forms as engine-speed governors and servo steering engines on ships.

A simple feedback system for temperature control is shown in figure 20. This is a *cause-and-effect* system. The furnace (F) raises the room temperature (T) to a predetermined value at which point the sensing thermostat (TH) reduces the fuel flow to the furnace. When the room temperature drops below the predetermined value the fuel flow is increased by the thermostat control. An interdependent control system is created by this arrangement: the room temperature depends on the thermostat action, and the thermostat action depends on the room temperature. This sequence of events may be termed a *closed-loop feedback system*.

Error Cancellation A feedback control system is dependent on a degree of error in the output signal, since this error component is used to bring about the correction. This component is called the *error signal*. The error, or deviation from the desired signal is passed through the feedback loop to cause an adjustment to reduce the value of the error signal. Care must be taken in the design of the feedback loop to reduce over-control tendencies wherein the correction signal would carry the system past the point of correct operation. Under certain circumstances the new error signal would

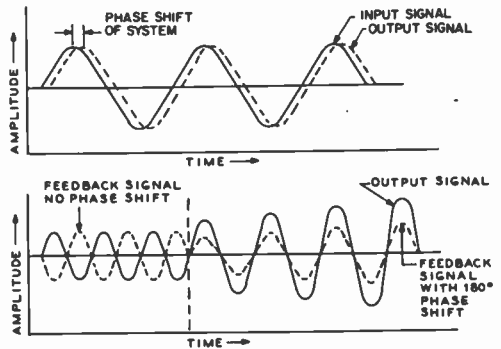

Figure 21

PHASE SHIFT OF ERROR SIGNAL MAY CAUSE OSCILLATION IN CLOSED LOOP SYSTEM

To prevent oscillation, the gain of the feedback loop must be less than unity when the phase shift of the system reaches 180 degrees.

cause the feedback control to overcorrect in the opposite direction, resulting in *bunting* or oscillation of the closed-loop system about the correct operating point.

Negative-feedback control would tend to damp out spurious system oscillation if it were not for the time lag or phase shift in the system. If the over-all phase shift is equal to one-half cycle of the operating frequency of the system, the feedback will maintain a steady state of oscillation when the circuit gain is sufficiently high (figure 21). In order to prevent oscillation, the gain figure of the feedback loop must be less than unity when the phase shift of the system reaches 180 degrees. In an ideal control system the gain of the loop would be constant throughout the operating range of the device, and would drop rapidly outside the range to reduce the bandwidth of the control system to a minimum.

The time lag in a closed-loop system may be reduced by using electronic circuits in place of mechanical devices, or by the use of special circuit elements having a *phase-lead* characteristic. Such devices make use of the properties of a capacitor, wherein the current leads the voltage applied to it.

Radio Receiver Fundamentals

A conventional reproducing device such as a speaker or a pair of earphones is incapable of receiving directly the intelligence carried by the carrier or sidebands of a radio transmitting station. It is necessary that an additional device, called a *radio receiver*, be placed between the receiving antenna and the speaker or headphones.

Radio receivers vary widely in their complexity and basic design, depending on the intended application and economic factors. A simple radio receiver for reception of radiotelephone signals can consist of an earphone, a silicon or germanium crystal as a carrier rectifier or *demodulator*, and a length of wire as an antenna. However, such a receiver is highly insensitive, and offers no significant discrimination between two signals in the same portion of the spectrum.

On the other hand, a dual-diversity receiver designed for single-sideband reception and employing double or triple detection might occupy several relay racks and would cost many thousands of dollars. However, conventional communications receivers are intermediate in complexity and performance between the two extremes. This chapter is devoted to the principles underlying the operation of such conventional communications receivers.

10-1 Detection or Demodulation

A *detector*, or *demodulator*, is a device for removing the modulation (demodulating) or

detecting the intelligence carried by an incoming radio wave.

Radiotelephony Demodulation Figure 1 illustrates an elementary form of a radiotelephone receiver employing a diode detector. Energy from a passing radio wave will induce a voltage in the antenna and cause a radio-frequency current to flow from antenna to ground through coil L_1 . The alternating magnetic field set up around L_1 links with the turns of L_2 and causes an r-f current to flow through the parallel-tuned circuit, (L_2 - C_1). When variable capacitor C_1 is adjusted so that the tuned circuit is resonant at the frequency of the applied signal, the r-f voltage is maximum. This r-f voltage is applied to the diode detector where it is rectified into a varying direct current, which is passed through the earphones. The variations in this current correspond to the voice modulation placed on the signal at the transmitter. As the earphone diaphragms vibrate back and forth in accord with the pulsating current they audibly reproduce the modulation which was placed on the carrier wave.

The operation of the detector circuit is shown graphically above the detector circuit in figure 1. The modulated carrier is shown at A, as it is applied to the antenna. B represents the same carrier, increased in amplitude, as it appears across the tuned circuit. In C the varying d-c output from the detector is seen.

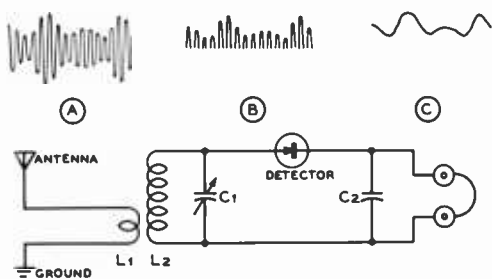

Figure 1

ELEMENTARY FORM OF RECEIVER

This is the basis of the "crystal set" type of receiver. The tank circuit (L_2 - C_1) is tuned to the frequency it is desired to receive. The bypass capacitor across the phones should have a low reactance to the carrier frequency being received, but a high reactance to the modulation on the received radio signal.

Radiotelegraphy Reception

Since a c-w telegraphy signal consists of an unmodulated carrier which is interrupted to form dots and dashes, it is apparent that such a signal would not be made audible by detection alone. While the keying is a form of modulation, it is composed of such low-frequency components that the keying envelope itself is below the audible range at hand-keying speeds. Some means must be provided whereby an audible tone is heard while the unmodulated carrier is being received, the tone stopping immediately when the carrier is interrupted.

The most simple means of accomplishing this is to feed a locally generated carrier of a slightly different frequency into the same detector, so that the incoming signal will mix with it to form an audible beat note. The difference frequency, or heterodyne as the beat note is known, will of course stop and start in accord with the incoming c-w radiotelegraph signal, because the audible heterodyne can exist only when both the incoming and the locally generated carriers are present.

The Autodyne Detector The local signal which is used to beat with the desired c-w signal in the detector may be supplied by a separate low-power oscillator in the receiver itself, or the detector may be made to self-oscillate, and thus serve the

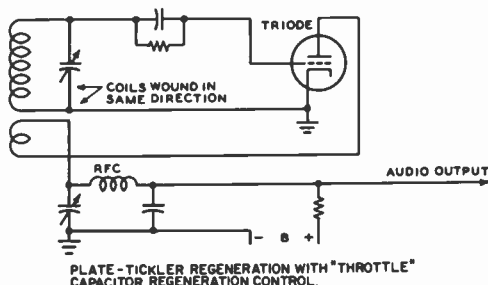
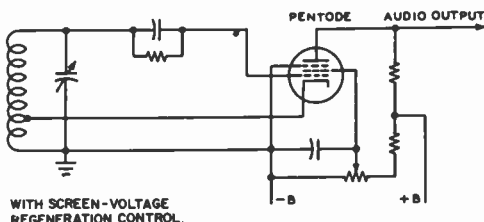

PLATE-TICKLER REGENERATION WITH "THROTTLE" CAPACITOR REGENERATION CONTROL.



WITH SCREEN-VOLTAGE REGENERATION CONTROL.

Figure 2

REGENERATIVE DETECTOR CIRCUITS

Regenerative detectors are seldom used at the present time due to their poor selectivity. Detector may be used for c.w. or SSB when adjusted for oscillation or for a-m phone when set just below point of oscillation.

dual purpose of detector and oscillator. A detector which self-oscillates to provide a beat note is known as an autodyne detector, and the process of obtaining feedback between the detector plate and grid is called regeneration.

An autodyne detector is most sensitive when it is barely oscillating, and for this reason a regeneration control is always included in the circuit to adjust the feedback to the proper amount. The regeneration control may be either a variable capacitor or a variable resistor, as shown in figure 2.

Superregenerative Receivers

At ultrahigh frequencies, when it is desired to keep weight and cost at a minimum a special form of the regenerative receiver known as the superregenerator is often used for radiotelephony reception. The superregenerator is essentially a regenerative receiver with a means provided to throw the detector rapidly in and out of oscillation. The frequency at which the detector is made to go in and out of oscillation varies with the frequency to be received, but is usually between 20,000 and 500,000 times a second. This su-

perregenerative action considerably increases the sensitivity of the oscillating detector so that the usual *background hiss* is greatly amplified when no signal is being received.

The simplest type of superregenerative detector circuit is arranged so as to produce its own interruption frequency oscillation, without the aid of a separate tube. The detector tube or transistor damps (or quenches) itself out of signal-frequency oscillation at a high rate by virtue of the use of a high value of grid resistor and proper size blocking and coupling capacitors, in conjunction with an excess of feedback. A representative self-quenched superregenerative detector circuit is shown in figure 3.

The optimum quenching frequency is a function of the signal frequency. As the operating frequency goes up, so does the optimum quenching frequency. When the quench frequency is too low, maximum sensitivity is not obtained. When it is too high, both sensitivity and selectivity suffer. In fact, the optimum quench frequency for an operating frequency below 15 MHz is in the audible range. This makes the superregenerator impractical for use on the lower frequencies.

The selectivity of a superregenerator is rather poor compared to a superheterodyne, but is surprisingly good for so simple a receiver when figured on a percentage basis rather than absolute kHz bandwidth.

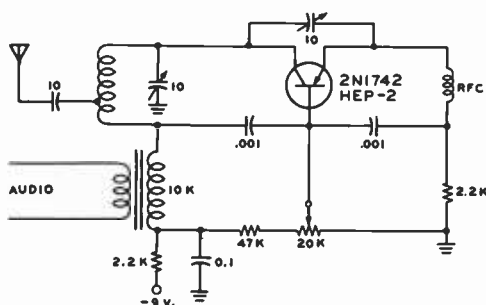

Figure 3

SUPERREGENERATIVE DETECTOR FOR VHF

A self-quenched superregenerative detector is capable of giving good sensitivity in the vhf range, but has relatively poor selectivity. Such a circuit should be preceded by an r-f stage to suppress radiation from the oscillating detector.

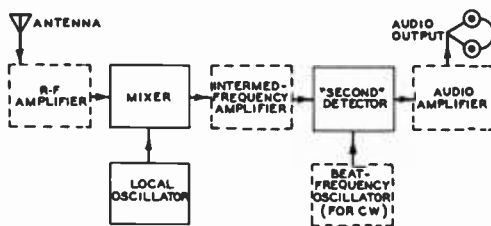

Figure 4

ESSENTIAL UNITS OF A SUPERHETERODYNE RECEIVER

The basic portions of the receiver are shown in solid blocks. Practicable receivers employ the dotted blocks and also usually include such additional circuits as a noise limiter, an avc circuit, and a crystal filter in the i-f amplifier.

Superregenerative receivers radiate a strong, broad, and rough signal. For this reason, it is necessary in most applications to employ a radio-frequency amplifier stage ahead of the detector, with thorough shielding throughout the receiver.

A transistorized superregenerative detector is normally used in the inexpensive Citizen's Band hand-held transceivers and is occasionally used in portable gear in the amateur 144-MHz and 224-MHz bands.

10-2 Superheterodyne Receivers

Because of its superiority and nearly universal use in all fields of radio reception, the theory of operation of the superheterodyne should be familiar to every radio student and experimenter. The following discussion concerns superheterodynes for a-m and SSB reception. It is, however, applicable in part to receivers for frequency modulation.

Principle of Operation In the superheterodyne, the incoming signal is applied to a *mixer* consisting of a nonlinear impedance such as a vacuum tube, transistor, or diode. The signal is mixed with a steady signal generated locally in an oscillator stage, with the result that a signal bearing all the modulation applied to the original signal *but of a frequency equal to the difference between the local oscillator and incoming signal frequencies* appears in the mixer output

circuit. The output from the mixer stage is fed into a fixed-tuned *intermediate-frequency amplifier*, where it is amplified and detected in the usual manner, and passed on to the audio amplifier. Figure 4 shows a block diagram of the fundamental superheterodyne arrangement. The basic components are shown in heavy lines, the simplest superheterodyne consisting simply of these three units. However, a good communications receiver will comprise all of the elements shown, both heavy and dotted blocks.

Advantages of the Superheterodyne The advantages of superheterodyne reception are directly attributable to the

use of the fixed-tuned *intermediate-frequency (i-f) amplifier*. Since all signals are converted to the intermediate frequency, this section of the receiver may be designed for optimum selectivity and high amplification. High amplification is easily obtained in the intermediate-frequency amplifier, since it operates at a relatively low frequency, where conventional pentode-type tubes and transistors give adequate voltage gain. A typical intermediate-frequency amplifier is shown in figure 5.

From the diagram it may be seen that both the input and output circuits are tuned. The tuned circuits used for coupling between i-f stages are known as *i-f transformers*. These will be more fully discussed later in this chapter.

Choice of Intermediate Frequency The choice of a frequency for the i-f amplifier involves several considerations. One of these considerations concerns selectivity—the lower the intermediate frequency the greater the obtainable selectivity. On the other hand, a rather high intermediate frequency is desirable from the standpoint of *image* elimination, and also for the reception of signals from television and f-m transmitters and modulated self-controlled oscillators, all of which occupy a rather wide band of frequencies, making a broad selectivity characteristic desirable. Images are a peculiarity common to all superheterodyne receivers, and for this reason they are given a detailed discussion later in this chapter.

While intermediate frequencies as low as 50 kHz are used where extreme selectivity is a requirement, and frequencies of 60 MHz

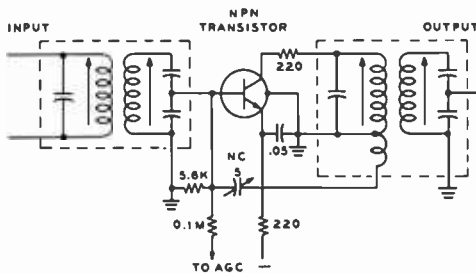

Figure 5

TYPICAL I-F AMPLIFIER STAGE

and above are used in some specialized forms of receivers, most present-day communications superheterodynes use intermediate frequencies around either 455 or 1600 kHz.

Home-type broadcast receivers almost always use an intermediate frequency in the vicinity of 455 kHz, while auto receivers usually use a frequency of about 262 kHz. The standard frequency for the i-f channel of f-m receivers is 10.7 MHz. Television receivers use an intermediate frequency which covers the band between 41 and 46 MHz.

Arithmetical Selectivity Aside from allowing the use of fixed-tuned bandpass amplifier stages, the superheterodyne has an overwhelming advantage over the tuned radio frequency (trf) type of receiver because of what is commonly known as *arithmetical selectivity*.

This can best be illustrated by considering two receivers, one of the trf type and one of the superheterodyne type, both attempting to receive a desired signal at 10,000 kHz and eliminate a strong interfering signal at 10,010 kHz. In the trf receiver, separating these two signals in the tuning circuits is practically impossible, since they differ in frequency by only 0.1 percent. However, in a superheterodyne with an intermediate frequency of, for example, 1000 kHz, the desired signal will be converted to a frequency of 1000 kHz and the interfering signal will be converted to a frequency of 1010 kHz, both signals appearing at the input of the i-f amplifier. In this case, the two signals may be separated much more readily, since they differ by 1 percent, or 10 times as much as in the first case.

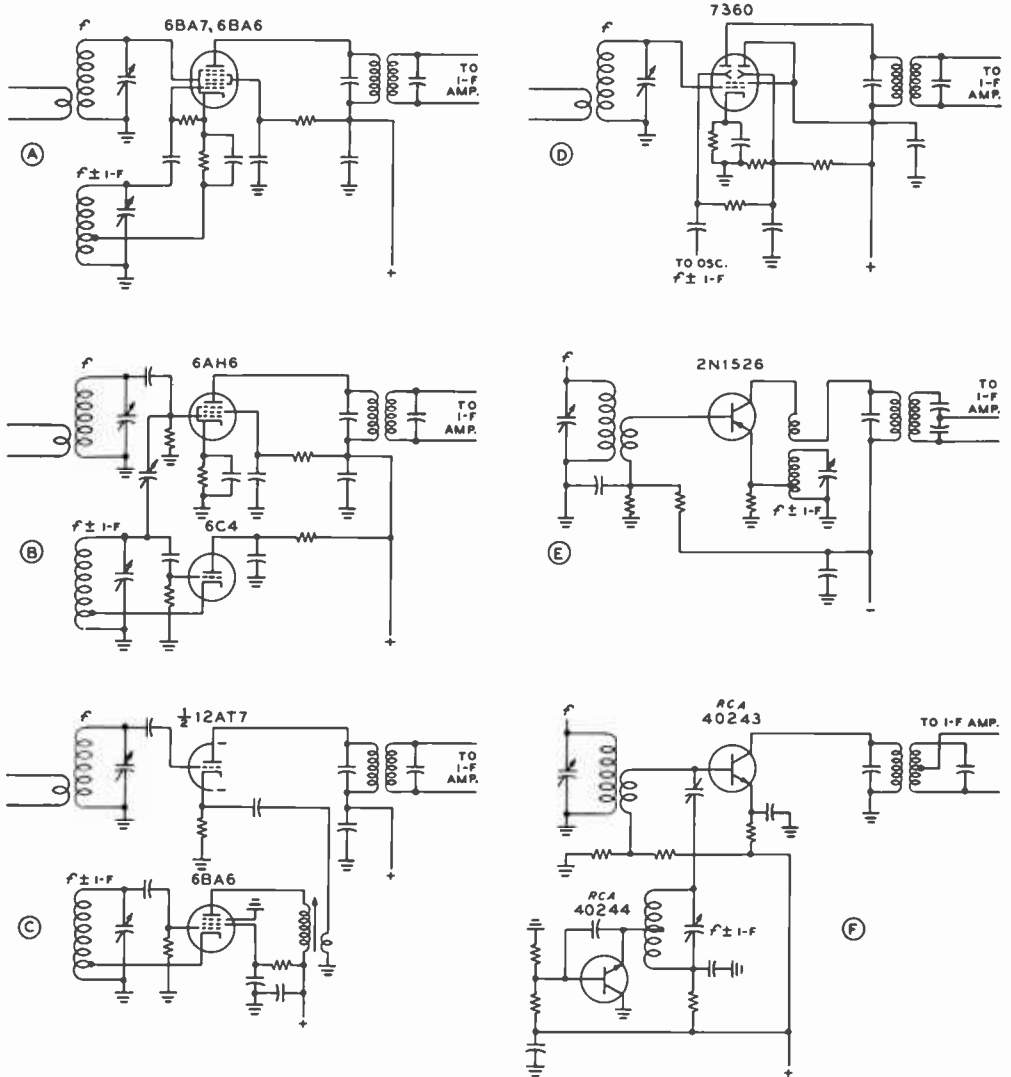

Figure 6

TYPICAL FREQUENCY-CONVERTER (MIXER) STAGES

A—Pentagrid converter. **B**—Pentode mixer with grid injection. **C**—Triode mixer with cathode injection. **D**—Beam-deflection mixer. **E**—Transistor self-oscillating (autodyne) mixer. **F**—Transistor mixer with base injection.

The Converter Stage The converter, or *mixer stage*, of a superheterodyne receiver can be either one of two types: (1) it may use a single mixer/oscillator element such as a 6BA7 tube or a transistor, or (2) it may use two tubes or transistors in an oscillator-mixer combina-

tion. Figure 6 illustrates typical circuits of both types. The *pentagrid converter* tube is shown in Figure 6A. Tubes of this type are good conversion devices at medium frequencies, although their performance drops off as the frequency of operation is raised. Their use is practical up to 50 MHz or so.

Electrically, grids 2 and 4 shield the signal grid from the oscillator section and also act as an anode for the electron-coupled oscillator portion of the tube which is composed of grid 1 and the cathode. The pentagrid converter is characterized by an equivalent noise resistance of several hundred thousand ohms, consequently it must be preceded by an r-f stage having a fairly high gain figure if a low noise factor is desired in the receiver.

A second frequency-conversion technique utilizes a separate oscillator tube and a pentode mixer (figure 6B). The local oscillator voltage is applied to the mixer control grid by capacitive or inductive coupling, or a combination of the two. Tubes containing electrically independent oscillator and mixer units in the same envelope, such as the 6U8A, 6KZ8, and 6EA8 are designed especially for this application and find use in TV tuners and f-m receivers. Another version of this circuit is shown in figure 6C utilizing a low-noise triode mixer with cathode injection from a separate electron-coupled oscillator. This circuit has a wide dynamic range and is capable of mixing relatively strong signals while retaining a low level of intermodulation distortion. Tube types 6DJ8 and 6CW4 are often used for h-f and vhf mixer operation.

A beam-deflection tube (7360) may be used as a mixer in the circuit of Figure 6D, providing low noise figure and high mixer gain. The incoming signal is applied to control grid 1 and the mixing signal from the separate local oscillator is applied to the deflection plates. The electron stream is modulated by the received signal and then switched from one collector anode to the other by the local oscillator switching voltage. The i-f output signal is taken from one deflection anode of the 7360 in the usual manner, although a push-pull output configuration may be used for improved local-oscillator rejection at the intermediate frequency.

Inexpensive transistor radios make use of an *autodyne mixer* such as shown in Figure 6E. The oscillator circuit is placed in the emitter lead, with inductive feedback to the collector circuit. In the h-f range stable mixer operation is more readily obtained when a separate transistor is used for the

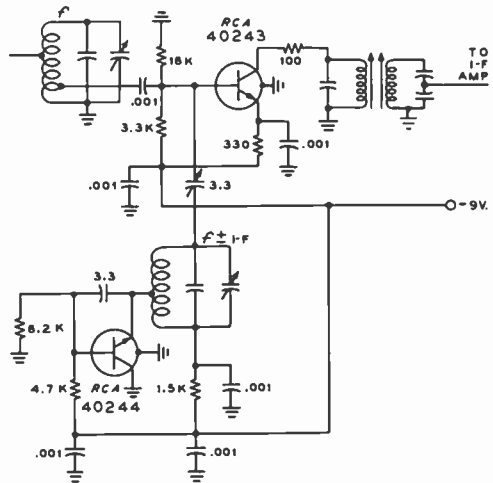

Figure 7

HIGH-FREQUENCY TRANSISTOR MIXER/OSCILLATOR

Local oscillator is capacitance coupled to base circuit of mixer. Circuit should be preceded by r-f stage to reduce radiation of local oscillator which is coupled to the input circuit of the mixer.

oscillator function. In the latter arrangement, the oscillator voltage is injected in the mixer stage by inductive coupling to the emitter, or a combination of inductive and capacitive coupling to emitter or base may be used (figure 7).

Mixers employing control-grid injection of the local mixing signal (figure 6B, for example) should be preceded by an r-f stage if local oscillator spurious radiation is to be held to a minimum.

Diode Mixers As the frequency of operation of a superheterodyne receiver is increased above a few hundred megahertz the signal-to-noise ratio appearing in the plate circuit of the mixer tube when triodes or pentodes are employed drops to a prohibitively low value. At frequencies above the upper frequency limit for conventional mixer stages, mixers of the diode type are most commonly employed. The diode may be either a vacuum-tube heater diode of a special uhf design such as the 9005, or it may be a germanium diode of the general type of the 1N21 through 1N28 series.

10-3 Noise and Spurious Products

Grid Circuit Considerations Since the full amplification of a receiver follows the first tuned circuit, the operating conditions existing in that circuit and in its coupling to the antenna on one side and to the grid of the first amplifier stage on the other are of greater importance in determining the signal-to-noise ratio of the receiver on weak signals.

First Tuned Circuit It is obvious that the highest ratio of signal to noise be impressed on the grid of the first r-f amplifier tube. Attaining the optimum ratio is a complex problem since noise will be generated in the antenna due to its equivalent radiation resistance (this noise is in addition to any noise of atmospheric origin) and in the first tuned circuit due to its equivalent coupled resistance at resonance. The noise voltage generated due to antenna radiation resistance and to equivalent tuned circuit resistance is similar to that generated in a resistor due to thermal agitation and is expressed by the following equation:

$$E_n = (4kTR\Delta f)^{1/2}$$

where,

E_n = rms value of noise voltage over the interval Δf ,

k = Boltzman's constant (1.380×10^{-23} joule per °K),

T = Absolute temperature °K,

R = Resistive component of impedance across which thermal noise is developed,

Δf = Frequency band across which voltage is measured.

In the above equation Δf is essentially the frequency band passed by the intermediate-frequency amplifier of the receiver under consideration. This equation can be greatly simplified for the conditions normally encountered in communications work. If we assume the following conditions: $T = 300^\circ$ K or 27° C or 80.5° F, room temperature; $\Delta f = 8000$ Hertz (the average passband of a communications receiver or speech amplifier), the equation reduces to: $E_n = 0.0115 \sqrt{R}$ microvolts. Accordingly, the

thermal-agitation voltage appearing in the center of a half-wave antenna (assuming effective temperature to be 300° K) having a radiation resistance of 73 ohms is approximately 0.096 microvolts. Also, the thermal-agitation voltage appearing across a 500,000-ohm grid resistor in the first stage of a speech amplifier is approximately 8 microvolts under the conditions cited above. Further, the voltage due to thermal agitation being impressed on the grid of the first r-f stage in a receiver by a first tuned circuit whose resonant resistance is 50,000 ohms is approximately 2.5 microvolts. Suffice to say, however, that the value of thermal-agitation voltage appearing across the first tuned circuit when the antenna is properly coupled to this circuit will be very much less than this value.

It is common practice to match the impedance of the antenna transmission line to the input impedance of the grid of the first r-f amplifier stage in a receiver. This is the condition of antenna coupling which gives maximum gain in the receiver. However, when vhf tubes such as nuvistors and miniatures are used at frequencies somewhat less than their maximum capabilities, a significant improvement in *signal-to-noise* ratio can be attained by *increasing* the coupling between the antenna and first tuned circuit to a value greater than that which gives greatest signal amplitude out of the receiver. In other words, in the 10-, 6-, and 2-meter bands it is possible to attain somewhat improved signal-to-noise ratio by increasing antenna coupling to the point where the gain of the receiver is slightly reduced.

It is always possible, in addition, to obtain improved signal-to-noise ratio in a vhf receiver through the use of tubes which have improved input impedance characteristics at the frequency in question over conventional types.

Noise Factor The limiting condition for sensitivity in any receiver is the thermal noise generated in the antenna and in the first tuned circuit. However, with proper coupling between the antenna and the grid of the tube, through the first tuned circuit, the noise contribution of the first tuned circuit can be made quite small. Unfortunately, though, the major noise contribution in a properly designed receiver is that

of the first tube. The noise contribution due to electron flow and due to losses in the tube can be lumped into an equivalent value of resistance which, if placed in the grid circuit of a perfect tube having the same gain but no noise would give the same noise voltage output in the plate load. The equivalent noise resistance of tubes such as the 6BA6, 6DC6, etc., runs from 500 to 1000 ohms. Very high G_m tubes such as the 6BZ6 and 6EH7 have equivalent noise resistances as low as 300 to 700 ohms. The lower the value of equivalent noise resistance, the lower will be the noise output under a fixed set of conditions.

The equivalent noise resistance of a tube must not be confused with the actual input loading resistance of a tube. For highest signal-to-noise ratio in an amplifier the input loading resistance should be as high as possible so that the amount of voltage that can be developed from grid to ground by the antenna energy will be as high as possible. The equivalent noise resistance should be as low as possible so that the noise generated by this resistance will be lower than that attributable to the antenna and first tuned circuit, and the losses in the first tuned circuit should be as low as possible.

The absolute sensitivity of receivers has been designated in recent years in government and commercial work by an arbitrary dimensionless number known as "noise factor" or N . The noise factor is the ratio of noise output of a "perfect" receiver having a given amount of gain with a dummy antenna matched to its input, to the noise output of the receiver having the same amount of gain with an injected signal, and the dummy antenna matched to its input. Although a perfect receiver is not a physically realizable thing, the noise factor of a receiver under measurement can be determined by calculation from the amount of additional noise (from a temperature-limited diode or other calibrated noise generator) required to increase the noise-power output of a receiver by a predetermined amount.

Tube Input Loading As has been mentioned in a previous paragraph, greatest gain in a receiver is obtained when the antenna is matched, through the r-f coupling transformer, to the input resistance

of the r-f tube. However, the higher the ratio of tube input resistance to equivalent noise resistance of the tube the higher will be the signal-to-noise ratio of the stage—and of course, the better will be the noise factor of the over-all receiver. The input resistance of a tube is very high at frequencies in the broadcast band and gradually decreases as the frequency increases. Tube input resistance of conventional tube types begins to become an important factor at frequencies of about 25 MHz and above. At frequencies above about 100 MHz the use of conventional tube types becomes impractical since the input resistance of the tube has become so much lower than the equivalent noise resistance that it is impossible to attain reasonable signal-to-noise ratio on any but very strong signals. Hence, special vhf tube types such as the 6BC5, 6CW4, and 6EH7 must be used.

The lowering of the effective input resistance of a vacuum tube at higher frequencies is brought about by a number of factors. The first, and most obvious, is the fact that the dielectric loss in the internal insulators, and in the base and press of the tube increases with frequency. The second factor is due to the fact that a finite time is required for an electron to move from the space charge in the vicinity of the cathode, pass between the grid wires, and travel on to the plate. The fact that the electrostatic effect of the grid on the moving electron acts over an appreciable portion of a cycle at these high frequencies causes a current flow in the grid circuit which appears to the input circuit feeding the grid as a resistance. The decrease in input resistance of a tube due to electron transit time varies as the square of the frequency. The undesirable effect of transit time can be reduced in certain cases by the use of higher plate voltages. Transit time varies inversely as the square root of the applied plate voltage.

Cathode lead inductance is an additional cause of reduced input resistance at high frequencies. This effect has been reduced in certain tubes such as the 6EA5 and the 6BC5 by providing two cathode leads on the tube base. One cathode lead should be connected to the input circuit of the tube and the other lead should be connected to the bypass capacitor for the plate return of the tube.

The reader is referred to the *Radiation Laboratory Series, Volume 23: Microwave Receivers* (McGraw-Hill, publishers) for additional information on noise factor and input loading of vacuum tubes.

10-4 Plate-Circuit Considerations

Noise is generated in a vacuum tube by the fact that the current flow within the tube is not a smooth flow but rather is made up of the continuous arrival of particles (electrons) at a very high rate. This *shot effect* is a source of noise in the tube, but its effect is referred back to the grid circuit of the tube since it is included in the *equivalent noise resistance* discussed in the preceding paragraphs.

Plate-Circuit Coupling For the purpose of this section, it will be considered that the function of the plate load circuit of a tuned vacuum-tube amplifier is to deliver energy to the next stage with the greatest efficiency over the required band of frequencies. Figure 8 shows three methods of interstage coupling for tuned r-f voltage amplifiers. In figure 8A ω is 2π times the resonant frequency of the circuit in the plate of the amplifier tube, and L and Q are the inductance and Q of the inductor L . In figure 8B the notation is the same and M is the mutual inductance between the primary coil and the secondary coil. In figure 8C the notation is again the same and k is the coefficient of coupling between the two tuned circuits. As the coefficient of coupling between the circuits is increased the bandwidth becomes greater but the response over the band becomes progressively more double-humped. The response over the band is the flattest when the Q 's of primary and secondary are approximately the same and the value of each Q is equal to $1.75/k$.

Spurious Products It is common practice to control the gain of a succession of r-f or i-f amplifier stages by varying the average bias on their control grids. However, as the bias is raised above the operating value on a conventional sharp-cutoff tube the tube becomes increasingly nonlinear in operation

as cutoff of plate current is approached. The effect of such nonlinearity is to cause cross-modulation between strong signals which appear on the grid of the tube. When a tube operating in such a manner is in one of the first stages of a receiver a number of signals are appearing on its grid simultaneously and cross-modulation between them will take place. The result of this effect is to produce a large number of spurious signals in the output of the receiver—in most cases these signals will carry the modulation of both the carriers which have been cross-modulated to produce the spurious signal.

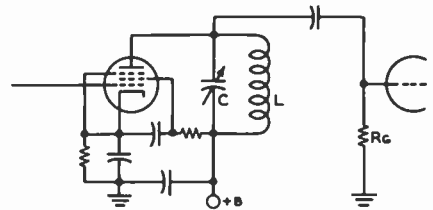

(A) AMPLIFICATION AT RESONANCE (APPROX.) = $G_m \omega L Q$

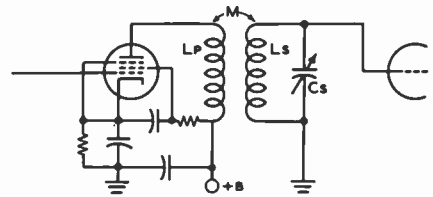

(B) AMPLIFICATION AT RESONANCE (APPROX.) = $G_m \omega M Q$

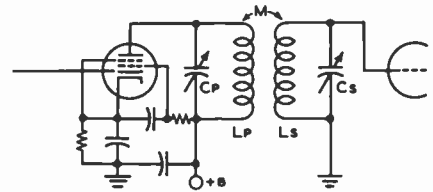

(C) AMPLIFICATION AT RESONANCE (APPROX.) = $G_m K \frac{\omega \sqrt{L_P L_S}}{K^2 + \frac{1}{Q_P Q_S}}$

WHERE: 1. PRI. AND SEC. RESONANT AT SAME FREQUENCY
2. K IS COEFFICIENT OF COUPLING

IF PRI. AND SEC. Q ARE APPROXIMATELY THE SAME:
 $\frac{\text{TOTAL BANDWIDTH}}{\text{CENTER FREQUENCY}} = 1.2 K$

MAXIMUM AMPLITUDE OCCURS AT CRITICAL COUPLING -
WHEN $K = \frac{1}{\sqrt{Q_P Q_S}}$

Figure 8

Gain equations for pentode r-f amplifier stages operating into a tuned load

The undesirable effect of cross-modulation can be eliminated in most cases and greatly reduced in the balance through the use of a variable- μ tube in all stages which have avc voltage or other large negative bias applied to their grids. The variable- μ tube has a characteristic which causes the cutoff of plate current to be gradual with an increase in grid bias, and the reduction in plate current is accompanied by a decrease in the effective amplification factor of the tube. Variable- μ tubes ordinarily have somewhat reduced G_m as compared to a sharp-cutoff tube of the same group. Hence the sharp-cutoff tube will perform best in stages to which avc voltage is not applied.

If the desired signal is strong enough, an attenuator pad may be placed between the receiver and the antenna, thus reducing the level of the undesired signal before it does harm. Remote cutoff tubes are advantageous for reducing cross-modulation from strong off-frequency signals.

Cross-modulation is a serious problem in transistorized receivers as most transistors have a very limited dynamic range, the FET types being the best in this respect, although not equal to remote-cutoff tubes.

When a receiver is tuned to a weak signal and a strong signal appears close to the received frequency, an apparent decrease in receiver gain may be noticed. This *blocking*, or *desensitization* occurs when the unwanted signal voltage drives a mixer or amplifier tube into the grid-current region, biasing the tube toward cutoff. Spurious voltage created by the flow of rectified grid current in a receiver stage may also be coupled back into the automatic volume control network, further reducing receiver gain.

The effects of *mixer noise* and *images* are troubles common to all superheterodynes. Since both these effects can largely be obviated by the same remedy, they will be considered together.

Mixer Noise Mixer noise of the shot-effect type, which is evidenced by a hiss in the audio output of the receiver, is caused by small irregularities in the plate current in the mixer stage and will mask weak signals. Noise of an identical nature is generated in an amplifier stage, but due to

the fact that the conductance in the mixer stage is considerably lower than in an amplifier stage using the same tube, the proportion of inherent noise present in a mixer usually is considerably greater than in an amplifier stage using a comparable tube.

Although this noise cannot be eliminated, its effects can be greatly minimized by placing sufficient signal-frequency amplification having a high signal-to-noise ratio ahead of the mixer. This remedy causes the signal output from the mixer to be large in proportion to the noise generated in the mixer stage. Increasing the gain *after* the mixer will be of no advantage in eliminating mixer noise difficulties; greater selectivity after the mixer will help to a certain extent, but cannot be carried too far, since this type of selectivity decreases the i-f bandpass and if carried too far will not pass the sidebands that are an essential part of a voice-modulated signal.

Triode Mixers A triode having a high transconductance is the *quietest* mixer tube, exhibiting somewhat less gain but a better signal-to-noise ratio than a comparable multigrad mixer tube. However, below 30 MHz it is possible to construct a receiver that will get down to the atmospheric noise level without resorting to a triode mixer. The additional difficulties experienced in avoiding *pulling*, undesirable feedback, etc., when using a triode with control-grid injection tend to make multigrad tubes the popular choice for this application on the lower frequencies.

On very-high frequencies, where set noise rather than atmospheric noise limits the weak-signal response, triode mixers are more widely used.

Injection Voltage The amplitude of the injection voltage will affect the conversion transconductance of the mixer, and therefore should be made optimum if maximum signal-to-noise ratio is desired. If fixed bias is employed on the injection grid, the optimum injection voltage is quite critical. If cathode bias is used, the optimum voltage is not so critical; and if grid-leak bias is employed, the optimum injection voltage is not at all critical—just so it is adequate. Typical optimum injection voltages will run from 1 to 3 volts for control-grid

injection, and 20 volts or so for screen- or suppressor-grid injection.

Images There always are *two* signal frequencies which will combine with a given frequency to produce the same difference frequency. For example: assume a superheterodyne with its oscillator operating on a higher frequency than the signal (which is common practice in many superheterodynes) tuned to receive a signal at 14,100 kHz. Assuming an i-f amplifier frequency of 450 kHz, the mixer input circuit will be tuned to 14,100 kHz, and the oscillator to 14,100 plus 450, or 14,550 kHz. Now, a *strong* signal at the oscillator frequency plus the intermediate frequency (14,550 plus 450, or 15,000 kHz) will also give a difference frequency of 450 kHz in the mixer output and will be heard also. Note that the image is always *twice* the intermediate frequency away from the desired signal. Images cause *repeat points* on the tuning dial.

The only way that the image could be eliminated in this particular case would be to make the selectivity of the mixer input circuit, and any circuits preceding it, great enough so that the 15,000-kHz signal never reaches the mixer grid in sufficient amplitude to produce interference.

For any particular intermediate frequency, image interference troubles become increasingly greater as the frequency (to which the signal-frequency portion of the receiver is tuned) is increased. This is due to the fact that the percentage difference between the desired frequency and the image frequency decreases as the receiver is tuned to a higher frequency. The ratio of strength between a signal at the image frequency and a signal at the frequency to which the receiver is tuned producing equal output is known as the *image ratio*. The higher this ratio is, the better the receiver will be in regard to image interference troubles.

With but a single tuned circuit between the mixer grid and the antenna, and with 400- to 500-kHz i-f amplifiers, image ratios of 60 db and over are easily obtainable up to frequencies around 2000 kHz. Above this frequency, greater selectivity in the mixer grid circuit through the use of additional tuned circuits between the mixer and the antenna is necessary if a good image ratio is to be maintained.

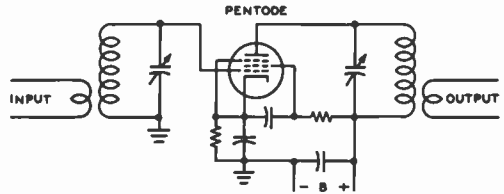

Figure 9

TYPICAL PENTODE R-F AMPLIFIER STAGE

10-5 R-F Stages

Since the necessary tuned circuits between the mixer and the antenna can be combined with tubes to form r-f amplifier stages, the reduction of the effects of mixer noise and the increasing of the image ratio can be accomplished in a single section of the receiver. When incorporated in the receiver, this section is known simply as an *r-f amplifier*; when it is a separate unit with a separate tuning control it is often known as a *pre-selector*. Either one or two stages are commonly used in the preselector or r-f amplifier. Some preselectors use regeneration to obtain still greater amplification and selectivity. An r-f amplifier or preselector embodying more than two stages rarely ever is employed since two stages will ordinarily give adequate gain to override mixer noise.

R-F Stages in the VHF Range Generally speaking, atmospheric noise in the frequency range above 30 MHz is quite low—so low, in fact, that the noise generated within the receiver itself is greater than the noise received on the antenna. Hence it is of the greatest importance that internally generated noise be held to a minimum in a receiver. At frequencies above 500 MHz there is not much that can be done in the direction of reducing receiver noise below that generated in the converter stage, aside from the use of specialized parametric amplifiers. But in the vhf range, between 30 and 500 MHz, the receiver noise factor in a well-designed unit is determined by the characteristics of the first r-f stage.

The usual vhf receiver, whether for communications or for f-m or TV reception, uses a miniature pentode or triode for the first r-f amplifier stage. The *nuvistors*

(6CW4 and 6DS4) are the best of presently available types, with the 6EH7 (pentode) and the cascode-style amplifier approaching *nuvistor* performance in the lower vhf region. However, when gain in the first r-f stage is not so important, and the best noise factor must be obtained, the first r-f stage usually uses a triode or a low-noise transistor.

Shown in figure 10 are four commonly used types of triode r-f stages for use in the vhf range. The circuit at (A) uses few components and gives a moderate amount of gain with very low noise. It is most satisfactory when the first r-f stage is to be fed directly from a low-impedance coaxial transmission line. Figure 10 (B) gives somewhat more gain than (A), but requires an input matching circuit. The effective gain of this circuit is somewhat reduced when it is being used to amplify a broad band of frequencies since the effective G_m of the cathode-coupled dual tube is somewhat less than half the G_m of either of the two tubes taken alone.

The Cascode Amplifier The *cascode* r-f amplifier is a low-noise circuit employing a grounded-cathode triode driving a grounded-grid triode, as shown in figure 10C. The stage gain of such a circuit is about equal to that of a pentode tube, while the noise figure remains at the low level of a triode tube. Neutralization of the first triode tube is usually unnecessary below 50 MHz. Above this frequency, a definite improvement in the noise figure may be obtained through the use of neutralization. The neutralizing coil (L_N) should resonate at the operating frequency with the grid-plate capacity of the first triode tube.

The TV-type double triodes such as the 6DJ8 (and older style 6BQ7 and 6BZ7) may be used to good advantage up to 144 MHz or so. At 2 meters and above, however, the 6CW4 *nuvistor* family is recommended for use.

Transistor R-F Amplifiers Three common transistor r-f amplifier stages are shown in figure 11. The *common-base amplifier* is shown in figure 11A. To overcome the possibility of oscillation at the higher frequencies, an external neutralizing circuit may be added, which consists of a neutralizing capacitor placed between the

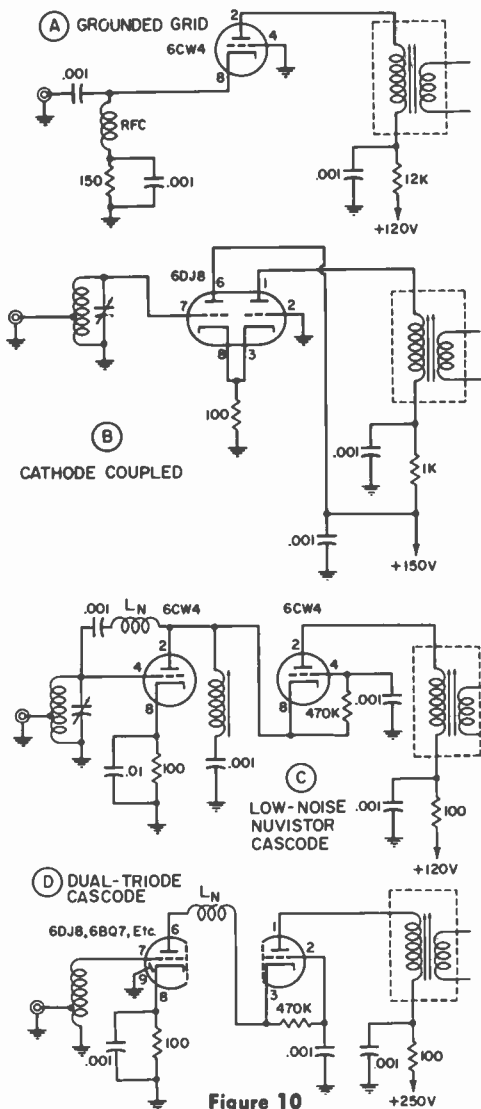

Figure 10

TYPICAL TRIODE VHF R-F AMPLIFIER STAGES

Triode r-f stages contribute the least amount of noise output for a given signal level, hence their frequent use in the vhf range.

collector and the lower end of the input circuit, which is lifted above ground. If the external feedback circuit cancels both resistive and reactive changes in the input circuit due to voltage feedback, the amplifier is considered to be *unilateralized*. If only the reactive changes in the input circuit are

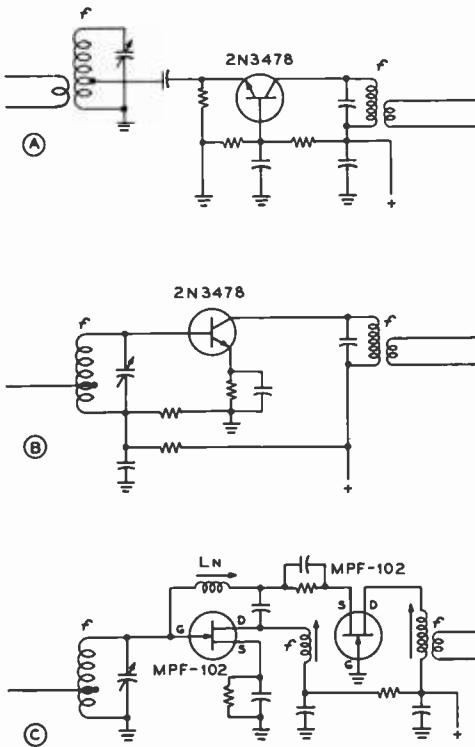

Figure 11

HIGH-FREQUENCY TRANSISTOR R-F STAGES

A—Common-base amplifier. B—Common-emitter amplifier. C—Cascode amplifier using FET transistors in cascode circuit.

cancelled, the amplifier is considered to be neutralized. Neutralization, then, is a special case of unilateralization. Modern silicon NPN epitaxial planar type transistors are designed for vhf use up to 470 MHz and many have sufficiently low feedback capacitance so that neutralization is unnecessary.

The *common-emitter amplifier* (figure 11B) corresponds to the grounded-cathode vacuum-tube circuit and provides the highest power gain of common transistor circuitry. As the phase of the output signal is opposite to that of the driving signal, the feedback from output to input circuit is essentially negative.

Field-effect transistors may be used in *common-source*, *common-gate*, or *common-drain* configurations. The common-source arrangement (figure 11C) is most frequently used as it provides high input im-

pedance and medium-to-high output impedance. The first neutralized transistor drives the second connected in common-gate configuration which is used to transform from a low or medium input impedance to a high output impedance. The relatively low voltage gain of the second stage makes dual neutralization unnecessary in most cases. The two FET transistors are arranged in a cascode amplifier circuit, with the first stage inductively neutralized by coil L_N . FET amplifiers of this type have been used to provide low noise reception at frequencies in excess of 500 MHz.

Double Conversion As previously mentioned, the use of a higher intermediate frequency will also improve the image ratio, at the expense of i-f selectivity, by placing the desired signal and the image farther apart. To give both good image ratio at the higher frequencies and good selectivity in the i-f amplifier, a system known as *double conversion* is sometimes employed. In this system, the incoming signal is first converted to a rather high intermediate frequency, and then amplified and again converted, this time to a much lower frequency. The first intermediate frequency supplies the necessary wide separation between the image and the desired signal, while the second one supplies the bulk of the i-f selectivity.

The double-conversion system, as illustrated in figure 12, is receiving two general types of application at the present time. The first application is for the purpose of attaining extremely good stability in a communications receiver through the use of crystal control of the first oscillator. In such an arrangement, as used in several types of Collins receivers, the first oscillator is crystal controlled and is followed by a tunable i-f amplifier which then is followed by a mixer stage and a fixed-tuned i-f amplifier on a much lower frequency. Through such a circuit arrangement the stability of the complete receiver is equal to the stability of the oscillator which feeds the second mixer, while the selectivity is determined by the bandwidth of the second fixed i-f amplifier.

The second common application of the double-conversion principle is for the purpose of obtaining a very high degree of se-

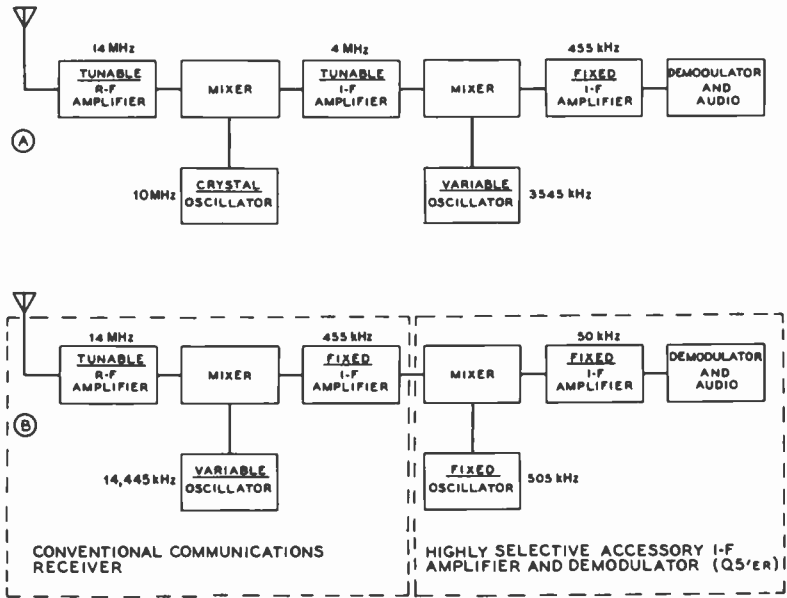

Figure 12

TYPICAL DOUBLE-CONVERSION SUPERHETERODYNE RECEIVERS

Illustrated at A is the basic circuit of a commercial double-conversion superheterodyne receiver. At B is illustrated the application of an accessory sharp i-f channel for obtaining improved selectivity from a conventional communications receiver through the use of the double-conversion superheterodyne principle.

lectivity in the complete communications receiver. In this type of application, as illustrated in figure 12B, a conventional communications receiver is modified in such a manner that its normal i-f amplifier (which usually is in the 450- to 915-kHz range) instead of being fed to a demodulator and then to the audio system, is alternatively fed to a fixed-tuned mixer stage and then into a much lower intermediate-frequency amplifier before the signal is demodulated and fed to the audio system. The accessory i-f amplifier system (sometimes called a Q5'er) normally is operated on a frequency of 175 kHz, 85 kHz, or 50 kHz.

10-6 Signal-Frequency Tuned Circuits

The signal-frequency tuned circuits in high-frequency superheterodynes and tuned-radio-frequency types of receivers consist of coils of either the solenoid or universal-

wound types shunted by variable capacitors. It is in these tuned circuits that the causes of success or failure of a receiver often lie. The universal-wound type coils usually are used at frequencies below 2000 kHz; above this frequency the single-layer solenoid type of coil is more satisfactory.

Impedance and Q The two factors of greatest significance in determining the gain-per-stage and selectivity, respectively, of a tuned amplifier are tuned-circuit impedance and tuned-circuit Q. Since the resistance of modern capacitors is low at ordinary frequencies, the resistance usually can be considered to be concentrated in the coil. The resistance to be considered in making Q determinations is the r-f resistance, not the d-c resistance of the wire in the coil. The latter ordinarily is low enough that it may be neglected. The increase in r-f resistance over d-c resistance primarily is due to skin effect and is influenced by such factors as wire size and type, and the proximity of

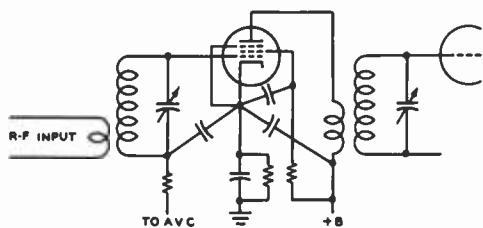

Figure 13

ILLUSTRATING "COMMON-POINT" BYPASSING

To reduce the detrimental effects of cathode circuit inductance in vhf stages, all bypass capacitors should be returned to the cathode terminal at the socket. Tubes with two cathode leads can give improved performance if the grid return is made to one cathode terminal while the plate and screen bypass returns are made to the cathode terminal which is connected to the suppressor within the tube.

metallic objects or poor insulators, such as coil forms with high losses. Higher values of Q lead to better selectivity and increased r-f voltage across the tuned circuit. The increase in voltage is due to an increase in the circuit impedance with the higher values of Q .

Frequently it is possible to secure an increase in impedance in a resonant circuit (and consequently an increase in gain from an amplifier stage) by increasing the reactance through the use of larger coils and smaller tuning capacitors (higher LC ratio).

Input Resistance Another factor which influences the operation of tuned circuits is the input resistance of the tubes placed across these circuits. At broadcast frequencies, the input resistance of most conventional r-f amplifier tubes is high enough so that it is not bothersome. But as the frequency is increased, the input resistance becomes lower and lower, until it ultimately reaches a value so low that no amplification can be obtained from the r-f stage.

The two contributing factors to the decrease in input resistance with increasing frequency are the transit time required by an electron traveling between the cathode and grid, and the inductance of the cathode lead common to both the plate and grid circuits. As the frequency becomes higher, the transit time can become an appreciable portion of the time required by an r-f cycle of the signal voltage, and current will actually

flow into the grid. The result of this effect is similar to that which would be obtained by placing a resistance between the grid and cathode of the tube.

Superheterodyne Tracking Because the oscillator in a superheterodyne operates

"offset" from the other front-end circuits, it is necessary to make special provisions to allow the oscillator to track when similar tuning capacitor sections are ganged. The usual method of obtaining good tracking is to operate the oscillator on the high-frequency side of the mixer and use a *series tracking capacitor* to slow down the tuning rate of the oscillator. The oscillator tuning rate must be slower because it covers a smaller range than does the mixer when both are expressed as a percentage of frequency. At frequencies above 7000 kHz and with ordinary intermediate frequencies, the difference in percentage between the two tuning ranges is so small that it may be disregarded in receivers designed to cover only a small range, such as an amateur band.

A mixer- and oscillator-tuning arrangement in which a series tracking capacitor is provided is shown in figure 14. The value of the tracking capacitor varies considerably with different intermediate frequencies and

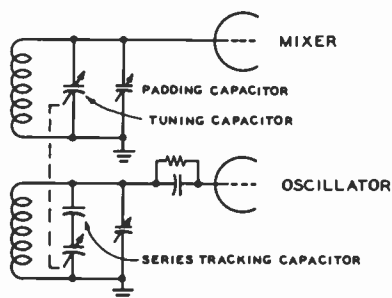

Figure 14

SERIES TRACKING EMPLOYED IN THE H-F OSCILLATOR OF A SUPERHETERODYNE

The series tracking capacitor permits the use of identical gangs in a ganged capacitor, since the tracking capacitor slows down the rate of frequency change in the oscillator so that a constant difference in frequency between the oscillator and the r-f stage (equal to the i-f amplifier frequency) may be maintained.

tuning ranges, capacitances as low as .0001 μfd being used at the lower tuning-range frequencies, and values up to .01 μfd being used at the higher frequencies.

Superheterodyne receivers designed to cover only a single frequency range, such as the standard broadcast band, sometimes obtain tracking between the oscillator and the r-f circuits by cutting the variable plates of the oscillator tuning section to a different shape than those used to tune the r-f stages.

Frequency Range Selection The frequency to which a receiver responds may be varied by changing the size of either the coils or the capacitors in the tuning circuits, or both. In short-wave receivers a combination of both methods is usually employed, the coils being changed from one band to another, and variable capacitors being used to tune the receiver across each band. In practical receivers, coils may be changed by one of two methods: a switch, controllable from the panel, may be used to switch coils of different sizes into the tuning circuits or, alternatively, coils of different sizes may be plugged manually into the receiver, the connection into the tuning circuits being made by suitable plugs on the coils. Where there are several *plug-in coils* for each band, they are sometimes arranged on a single mounting strip, allowing them all to be plugged in simultaneously.

Bandsread Tuning In receivers using large tuning capacitors to cover the short-wave spectrum with a minimum

of coils, tuning is likely to be quite difficult, owing to the large frequency range covered by a small rotation of the variable capacitors. To alleviate this condition, some method of slowing down the tuning rate, or *bandspreading*, must be used.

Quantitatively, bandspread is usually designated as being inversely proportional to the range covered. Thus, a *large* amount of bandspread indicates that a *small* frequency range is covered by the bandspread control. Conversely, a *small* amount of bandspread is taken to mean that a *large* frequency range is covered by the bandspread dial.

Types of Bandspread Bandspreading systems are of two general types: electrical and mechanical. Mechanical systems are exemplified by high-ratio dials in which the tuning capacitors rotate much more slowly than the dial knob. In this system, there is often a separate scale or pointer either connected or geared to the dial knob to facilitate accurate dial readings. However, there is a practical limit to the amount of mechanical bandspread which can be obtained in a dial and capacitor before the speed-reduction unit and capacitor bearings become prohibitively expensive. Hence, most receivers employ a combination of electrical and mechanical bandspread. In such a system, a moderate reduction in the tuning rate is obtained in the dial, and the rest of the reduction obtained by *electrical bandspreading*.

Stray Circuit Capacitance In this book and in other radio literature, mention is sometimes made of *stray or circuit capacitance*. This capacitance is in the usual sense defined as the capacitance remaining across a coil when all the tuning, bandspread, and padding capacitors across the circuit are at their minimum capacitance setting.

Circuit capacitance can be attributed to two general sources. One source is that due to the input and output capacitance of the tube when its cathode is heated. The input capacitance varies somewhat from the static value when the tube is in actual operation. Such factors as plate load impedance, grid bias, and frequency will cause a change in input capacitance. However, in all except the extremely high-transconductance tubes, the published measured input capacitance is

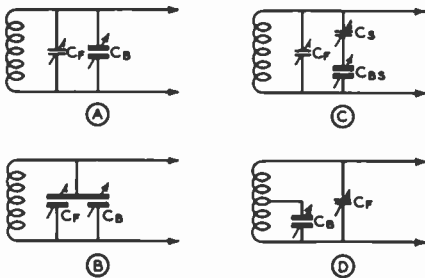

Figure 15

BANDSPREAD CIRCUITS

Parallel bandspread is illustrated at (A) and (B), series bandspread at (C), and tapped-coil band-spread at (D).

reasonably close to the effective value when the tube is used within its recommended frequency range. But in the high-transconductance types the effective capacitance will vary considerably from the published figures as operating conditions are changed.

The second source of circuit capacitance, and that which is more easily controllable, is that contributed by the minimum capacitance of the variable capacitors across the circuit and that due to capacitance between the wiring and ground. In well-designed high-frequency receivers, every effort is made to keep this portion of the circuit capacitance at a minimum since a large capacitance reduces the tuning range available with a given coil and prevents a good LC ratio, and consequently a high-impedance tuned circuit, from being obtained.

A good percentage of stray circuit capacitance is due also to distributed capacitance of the coil and capacitance between wiring points and chassis.

Typical values of circuit capacitance may run from 10 to 75 pf in high-frequency receivers, the first figure representing concentric-line receivers with nuvistor or miniature tubes and extremely small tuning capacitors, and the latter representing all-wave sets with bandswitching, large tuning capacitors, and conventional tubes.

10-7 I-F Circuits

I-f amplifiers usually employ bandpass circuits of some sort. A bandpass circuit is exactly what the name implies—a circuit for passing a band of frequencies. Bandpass arrangements can be designed for almost any degree of selectivity, the type used in any particular case depending on the ultimate application of the amplifier.

I-F Transformers Intermediate-frequency transformers ordinarily consist of two or more tuned circuits and some method of coupling the tuned circuits together. Some representative arrangements are shown in figure 16. The circuit shown at A is the conventional i-f transformer, with the coupling (M) between the tuned circuits being provided by inductive coupling from one coil to the other. As the coupling is increased, the selectivity curve becomes less peaked, and when a condition

known as *critical coupling* is reached, the top of the curve begins to flatten out. When the coupling is increased still more, a dip occurs in the top of the curve.

The windings for this type of i-f transformer, as well as most others, nearly always consist of small, flat universal-wound pies mounted either on a piece of dowel to provide an air core or on powdered iron for *iron-core* i-f transformers. The iron-core transformers generally have somewhat more gain and better selectivity than equivalent air-core units.

The circuits shown at figure 16B and C are quite similar. Their only difference is the type of mutual coupling used, an inductance being used at B and a capacitance at C. The operation of both circuits is similar. Three resonant circuits are formed by the components. In B, for example, one resonant circuit is formed by L_1 , C_1 , C_2 , and L_2 all in series. The frequency of this resonant circuit is just the same as that of a single one of the coils and capacitors, since the coils and capacitors are similar in both sides of the circuit, and the resonant frequency of the two capacitors and the two coils all in series is the same as that of a single coil and capacitor. The second resonant frequency of the complete circuit is determined by the characteristics of each half of the circuit containing the mutual coupling device. In B, this second frequency will be lower than the first, since the resonant frequency of L_1 , C_1 , and inductance M ; or L_2 , C_2 , and M is lower than that of a single coil and capacitor, due to the inductance of M being added to the circuit.

The opposite effect takes place in figure 16C, where the common coupling impedance is a capacitor. Thus, at C the second resonant frequency is higher than the first. In either case, however, the circuit has two resonant frequencies, resulting in a flat topped selectivity curve. The width of the top of the curve is controlled by the reactance of the mutual coupling component. As this reactance is increased (inductance made greater, capacitance made smaller), the two resonant frequencies become further apart and the curve is broadened.

In the circuit of figure 16D, there is inductive coupling between the center coil and each of the outer coils. The result of this ar-

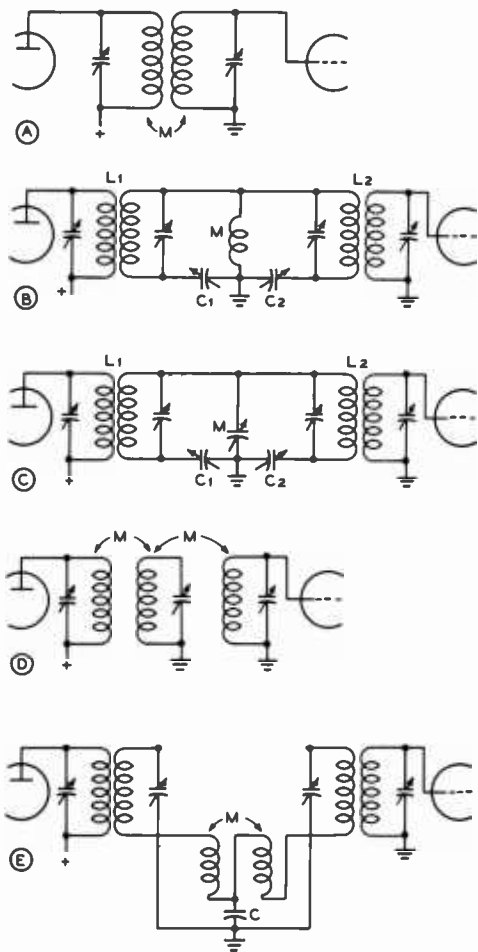

Figure 16

I-F AMPLIFIER COUPLING ARRANGEMENTS

The interstage coupling arrangements illustrated above give a better shape factor (more straight-sided selectivity curve) than would the same number of tuned circuits coupled by means of tubes.

arrangement is that the center coil acts as a sharply tuned coupler between the other two. A signal somewhat off the resonant frequency of the transformer will not induce as much current in the center coil as will a signal of the correct frequency. When a smaller current is induced in the center coil, it in turn transfers a still smaller current to the output coil. The effective coupling between the outer coils increases as the reso-

nant frequency is approached, and remains nearly constant over a small range and then decreases again as the resonant band is passed.

Another very satisfactory bandpass arrangement, which gives a very straight-sided, flat-topped curve, is the negative mutual arrangement shown in figure 16E. Energy is transferred between the input and output circuits in this arrangement by both the negative mutual coils (M) and the common capacitive reactance (C). The negative mutual coils are interwound on the same form, and connected backward.

Transformers usually are made tunable over a small range to permit accurate alignment in the circuit in which they are employed. This is accomplished either by means of a variable capacitor across a fixed inductance, or by means of a fixed capacitor across a variable inductance. The former usually employ either a mica-compression capacitor (designated "mica-tuned"), or a small air-dielectric variable capacitor (designated "air-tuned"). Those which use a fixed capacitor usually employ a powdered-iron core on a threaded rod to vary the inductance, and are known as "permeability-tuned."

Shape Factor It is obvious that to pass modulation sidebands and to allow for slight drifting of the transmitter carrier frequency and the receiver local oscillator, the i-f amplifier must pass not a single frequency but a band of frequencies. The width of this passband, usually 5 to 8 kHz at maximum width in a good communications receiver, is known as the *passband*, and is arbitrarily taken as the width between the two frequencies at which the response is attenuated 6 db, or is "6 db down." However, it is apparent that to discriminate against an interfering signal which is stronger than the desired signal, much more than 6 db attenuation is required. The attenuation commonly chosen to indicate adequate discrimination against an interfering signal is 60 db.

It is apparent that it is desirable to have the bandwidth at 60 db down as narrow as possible, but it must be done without making the passband (6-db points) too narrow for satisfactory reception of the desired sig-

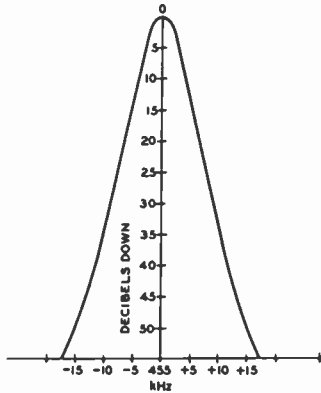

Figure 17

I-F PASSBAND OF TYPICAL COMMUNICATIONS RECEIVER

nal. The figure of merit used to show the ratio of bandwidth at 6 db down to that at 60 db down is designated as *shape factor*. The ideal i-f curve (a rectangle), would have a shape factor of 1.0. The i-f shape factor in typical communications receivers runs from 2.0 to 5.5.

The most practical method of obtaining a low shape factor for a given number of tuned circuits is to employ them in pairs, as in figure 16A, adjusted to *critical coupling* (the value at which two resonance points just begin to become apparent). If this gives too sharp a *nose* or passband, then coils of lower Q should be employed, with the coupling maintained at the critical value. As the Q is lowered, closer coupling will be required for critical coupling.

Conversely if the passband is too broad,

coils of higher Q should be employed, the coupling being maintained at critical. If the passband is made more narrow by using looser coupling instead of raising the Q and maintaining critical coupling, the shape factor will not be as good.

The *passband* will not be much narrower for several pairs of identical, critically coupled tuned circuits than for a single pair. However, the *shape factor* will be greatly improved as each additional pair is added, up to about 5 pairs, beyond which the improvement for each additional pair is not significant. Commercially available communications receivers of good quality normally employ 3 or 4 double-tuned transformers with coupling adjusted to critical or slightly less.

The passband of a typical communication receiver having a 455-kHz i-f amplifier is shown in figure 17.

Miller Effect As mentioned previously, the dynamic input capacitance of a tube varies slightly with bias. As *avc* voltage normally is applied to i-f tubes for radiotelephone reception, the effective grid-cathode capacitance varies as the signal strength varies, which produces the same effect as slight detuning of the i-f transformer. This effect is known as *Miller effect*, and can be minimized to the extent that it is not troublesome either by using a fairly low LC ratio in the transformers or by incorporating a small amount of degenerative feedback, the latter being most easily accomplished by leaving part of the cathode resistor un-bypassed for radio frequencies.

Crystal Filters The passband of an intermediate-frequency amplifier may be made very narrow through the use of a *piezoelectric crystal filter* employed as a series-resonant circuit in a bridge arrangement known as a *crystal filter*. The shape factor is quite poor, as would be expected when the selectivity is obtained from the equivalent of a single tuned circuit, but the very narrow passband obtainable as a result of the extremely high Q of the crystal makes the crystal filter useful for c-w telegraphy reception. The passband of a 455-kHz crystal filter may be made as narrow as 50 Hz while the narrowest passband that can be obtained with a 455-kHz tuned circuit of practical dimensions is about 5 kHz.

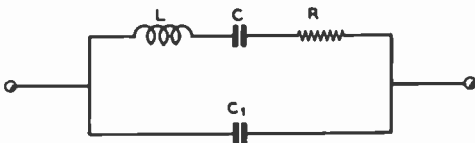

Figure 18

ELECTRICAL EQUIVALENT OF QUARTZ FILTER CRYSTAL

The crystal is equivalent to a very large value of inductance in series with small values of capacitance and resistance across the whole circuit (representing holder capacitance plus stray capacitances).

The electrical equivalent of a filter crystal is shown in figure 18. For a given frequency, L is very high, C very low, and R (assuming a good crystal of high Q) is very low. Capacitance C_1 represents the shunt capacitance of the electrodes, plus the crystal holder and wiring, and is many times the capacitance of C . This makes the crystal act as a parallel-resonant circuit with a frequency only slightly higher than that of its frequency of series resonance. For crystal filter use it is the series-resonant characteristic that we are primarily interested in.

The electrical equivalent of the basic crystal filter circuit is shown in figure 19. If the impedance of Z plus Z_1 is low compared to the impedance of the crystal (X) at resonance, then the current flowing through Z_1 , and the voltage developed across it, will be almost in inverse proportion to the impedance of X , which has a very sharp resonance curve.

In practical filter circuits the impedances Z and Z_1 usually are represented by some form of tuned circuit, but the basic principle of operation is the same.

Practical Filters It is necessary to balance out the capacitance across the crystal holder (C_1 in figure 18) to prevent bypassing around the crystal undesired signals off the crystal resonant frequency. The balancing is done by a *phasing* circuit which takes out-of-phase voltage from a balanced input circuit and passes it to the output side of the crystal in proper phase to neutralize that passed through the holder capacitance. A representative practical filter arrangement

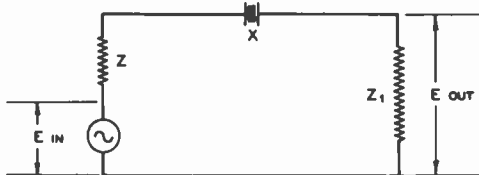

Figure 19
EQUIVALENT OF CRYSTAL FILTER CIRCUIT

For a given voltage out of the generator, the voltage developed across Z_1 depends on the ratio of the impedance of X to the sum of the impedances of Z and Z_1 . Because of the high Q of the crystal, its impedance changes rapidly with changes in frequency.

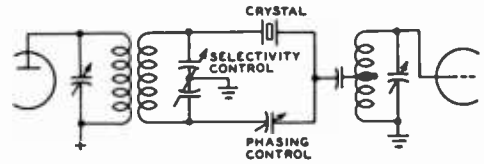

Figure 20
TYPICAL CRYSTAL FILTER CIRCUIT

is shown in figure 20. The balanced input circuit may be obtained either through the use of a split-stator capacitor as shown, or by the use of a center-tapped input coil.

Rejection Notch As previously discussed, a filter crystal has both a resonant (series-resonant) and an antiresonant (parallel-resonant) frequency—the impedance of the crystal being quite low at the former frequency, and quite high at the latter frequency. The antiresonant frequency is just slightly higher than the resonant frequency, the difference depending on the effective shunt capacitance of the filter crystal and holder. As adjustment of the phasing capacitor controls the effective shunt capacitance of the crystal, it is possible to vary the antiresonant frequency of the crystal slightly without unbalancing the circuit sufficiently to let undesired signals *leak through* the shunt capacitance in appreciable amplitude. At the exact antiresonant frequency of the

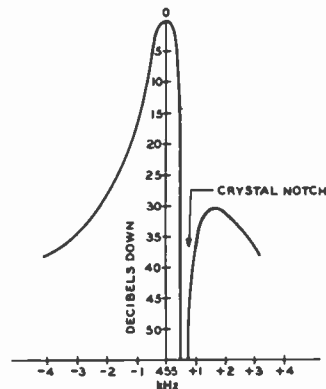

Figure 21
I-F PASSBAND OF TYPICAL CRYSTAL FILTER COMMUNICATION RECEIVER

crystal the attenuation is exceedingly high because of the high impedance of the crystal at this frequency. This is called the *rejection notch*, and can be utilized to virtually eliminate the heterodyne image or *repeat tuning* of c-w signals. The beat-frequency oscillator can be so adjusted and the phasing capacitor so adjusted that the desired beat note is of such a pitch that the image (the same audio note on the other side of zero beat) falls in the rejection notch and is inaudible. The receiver then is said to be adjusted for *single-signal* operation (figure 21).

Crystal Filter Considerations A crystal filter, especially when adjusted for *single-signal* reception, greatly reduces interference and background noise, the latter feature permitting signals to be copied that would ordinarily be too weak to be heard above the background hiss. However, when the filter is adjusted for maximum selectivity, the passband is so narrow that the received signal must have a high order of stability in order to stay within the passband. Likewise, the local oscillator in the receiver must be highly stable, or constant retuning will be required. Another effect that will be noticed with the filter adjusted too "sharp" is a tendency for code characters to produce a ringing sound, and have a hangover or "tails." This effect limits the code speed that can be copied satisfactorily when the filter is adjusted for extreme selectivity.

The Mechanical Filter The Collins Mechanical Filter (figure 22) is a new concept in the field of selectivity. It is an electromechanical bandpass filter about half the size of a cigarette package. As shown in figure 23, it consists of an input transducer, a resonant mechanical section comprised of a number of metal discs, and an output transducer.

The frequency characteristics of the resonant mechanical section provide the almost rectangular selectivity curves shown in figure 24. The input and output transducers serve only as electrical-to-mechanical coupling devices and do not affect the selectivity characteristics which are determined by the metal discs. An electrical signal applied to the input terminals is converted into a mechanical vibration at the input transducer by means of *magnetostriction*. This mechan-



Figure 22

COLLINS MECHANICAL FILTERS

The Collins Mechanical Filter is an electro-mechanical bandpass filter which surpasses, in one small unit, the selectivity of conventional, space-consuming filters. At the left is the miniaturized filter, less than 2 1/4" long. A vertical design is next, and two horizontal mounting types are at right.

ical vibration travels through the resonant mechanical section to the output transducer, where it is converted by magnetostriction to an electrical signal which appears at the output terminals.

In order to provide the most efficient electromechanical coupling, a small magnet in the mounting above each transducer applies a magnetic bias to the nickel transducer core. The electrical impulses then add to or subtract from this magnetic bias, causing vibration of the filter elements which corresponds to the exciting signal. There is no mechanical motion except for the imperceptible vibration of the metal discs.

Magnetostrictively driven mechanical filters have several advantages over electrical equivalents. In the region from 100 kHz to 500 kHz, the mechanical elements are extremely small, and a mechanical filter having better selectivity than the best of conventional i-f systems may be enclosed in a package smaller than one i-f transformer.

The frequency characteristics of the mechanical filter are permanent, and no adjustment is required or is possible. The filter is enclosed in a hermetically sealed case.

In order to realize full benefit from the mechanical filter's selectivity characteristics, it is necessary to provide shielding between

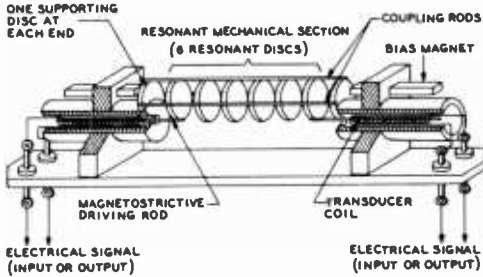

Figure 23

**MECHANICAL FILTER
FUNCTIONAL DIAGRAM**

the external input and output circuits, capable of reducing transfer of energy external to the filter by a minimum value of 100 db. If the input circuit is allowed to couple energy into the output circuit external to the filter, the excellent skirt selectivity will deteriorate and the passband characteristics will be distorted.

As with almost any mechanically resonant circuit, elements of the mechanical filter have multiple resonances. These result in spurious modes of transmission through the filter and produce minor passbands at frequencies outside the primary passband. Design of the filter reduces these subbands to a low level and removes them from the immediate area of the major passband. Two conventional i-f transformers supply increased attenuation to these spurious responses, and are sufficient to reduce them to an insignificant level.

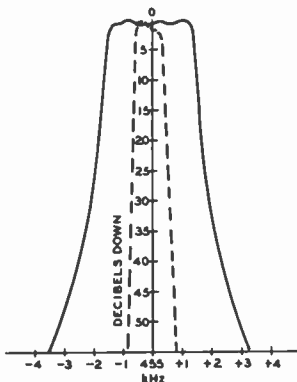
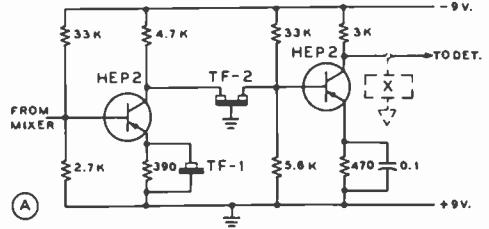
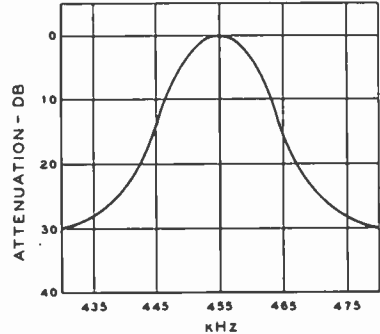

Figure 24

Selectivity curves of 455-kHz mechanical filters with nominal 0.8-kHz (dotted line) and 3.1-kHz (solid line) bandwidth at -6 db.



(A)



(B)

Figure 25

**MECHANICAL RESONATOR
USED AS I-F FILTER**

A—Transistorized i-f amplifier using Transfilters (TF-1, TF-2). Addition of second Transfilter (X) will sharpen selectivity. B—Passband of single Transfilter i-f stage with emitter resonator.

The Transfilter A small mechanical resonator (*transfilter*) may be used in place of an i-f transformer in transistor i-f circuits (figure 25A). A second transfilter resonator may be substituted for the conventional emitter bypass capacitor to enhance

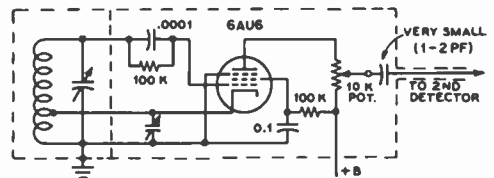

Figure 26

VARIABLE-OUTPUT BFO CIRCUIT

A beat-frequency oscillator whose output is controllable is of considerable assistance in copying c-w signals over a wide range of levels, and such a control is often employed for satisfactory copying of single-sideband signals.

i-f selectivity. Transfilters may also be employed in the high-Q oscillator tuned circuits. The passband of a single transfilter i-f stage with emitter resonator is shown in figure 25B.

Beat-Frequency Oscillators The *beat-frequency oscillator*, usually called the *bfo*, is a necessary adjunct for reception of c-w or SSB signals on superheterodynes which have no other provision for obtaining modulation of an incoming c-w or SSB signal. The oscillator is coupled into or just ahead of the second detector circuit and supplies a signal of nearly the same frequency as that of the desired signal from the i-f amplifier. If the i-f amplifier is tuned to 455 kHz, for example, the bfo is tuned to approximately 454 or 456 kHz to produce an audible (1000-Hz) beat note in the output of the second detector of the receiver. The carrier signal itself is, of course, inaudible. The bfo is not used for a-m reception, except as an aid in searching for weak stations.

The bfo input to the second detector need only be sufficient to give a good beat note on an average signal. Too much coupling into the second detector will give an excessively high hiss level, masking weak signals by the high noise background.

The bfo input to the second detector need only be sufficient to give a good beat note on an average signal. Too much coupling into the second detector will give an excessively high hiss level, masking weak signals by the high noise background.

Figure 26 shows a method of manually adjusting the bfo output to correspond with the strength of received signals. This type of variable bfo output control is a useful

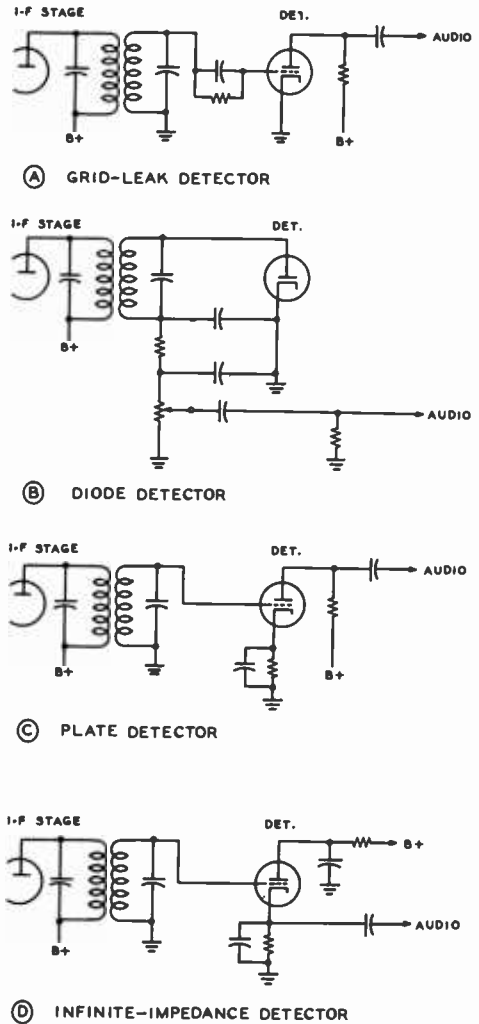

Figure 28

TYPICAL CIRCUITS FOR GRID-RESISTOR, DIODE, PLATE, AND INFINITE-IMPEDANCE DETECTOR STAGES

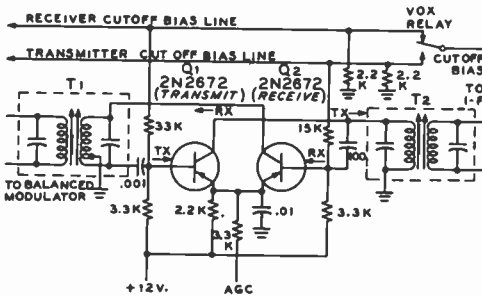

Fig. 27

BILATERAL I-F AMPLIFIER FOR TRANSCEIVER

Bilateral i-f amplifier stage functions in both receive and transmit modes in SSB transceiver. Cutoff-bias lines transfer operation from transistor Q₁ to transistor Q₂, as VOX relay is actuated. Common-emitter stages are used with base-bias control.

adjunct to any superheterodyne, since it allows sufficient bfo output to be obtained to *beat* with strong signals or to allow single-sideband reception and at the same time permits the bfo output, and consequently the hiss, to be reduced when attempting to receive weak signals. The circuit shown is somewhat better than those in which one of the electrode voltages on the bfo tube is changed, as the latter circuits usually change

the frequency of the bfo at the same time they change the strength, making it necessary to reset the trimmer each time the output is adjusted.

The bfo usually is provided with a small trimmer which is adjustable from the front panel to permit adjustment over a range of 5 or 10 kHz. For single-signal reception the bfo always is adjusted to the high-frequency side, in order to permit placing the heterodyne image in the rejection notch.

In order to reduce the bfo signal output voltage to a reasonable level which will prevent blocking the second detector, the signal voltage is delivered through a low-capacitance (high-reactance) capacitor having a value of 1 to 10 pf.

Care must be taken with the bfo to prevent harmonics of the oscillator from being picked up at multiples of the bfo frequency. The complete bfo together with the coupling circuits to the second detector, should be thoroughly shielded to prevent pickup of the harmonics by the input end of the receiver.

If bfo harmonics still have a tendency to give trouble after complete shielding and isolation of the bfo circuit has been accomplished, the passage of these harmonics from the bfo circuit to the rest of the receiver can be stopped through the use of a low-pass filter in the lead between the output of the bfo circuit and the point on the receiver where the bfo signal is to be injected.

Bilateral Amplifier A *bilateral amplifier* is one that amplifies in two signal directions (figure 27). Such a stage is useful in SSB transceivers wherein r-f and i-f stages function in both receive and transmit modes. During the receive function, the bilateral amplifier passes the signal from the mixer to the balanced modulator and during transmit it passes the signal in the opposite direction—from the balanced modulator to the mixer. The same tuned circuits are used for both transmitting and receiving. The various injection oscillators operate continuously, supplying the local mixing signals to the proper mixer stages.

In the circuit shown, the amplifier operates in the common-emitter configuration. In the receive mode, the 33K base-bias resistor is returned to the receiver cutoff-bias control line, disabling transistor Q_1 .

The 15K base-bias resistor of transistor Q_2 is returned to the transmitter-bias control circuit, which is at ground potential when the VOX relay is actuated. Thus, in the receive mode, a signal appearing at the receiver i-f transformer (T_2) will be amplified by transistor Q_2 and delivered to the i-f transformer (T_1). When the VOX circuit is activated to the transmit mode, the two bias-control lines are inverted in polarity so that transistor Q_2 is cut off and Q_1 is able to conduct. Therefore, a signal appearing at transformer T_1 is amplified by Q_1 and impressed on transformer T_2 . Unilateral stages that are not required on either transmit or receive may be turned off by returning their base-bias resistors to an appropriate cutoff-bias control line.

10-8 Detector, Audio, and Control Circuits

Detectors Second detectors for use in superheterodynes are usually of the diode, plate, or infinite-impedance types (figure 28). Occasionally, grid-resistor detectors are used in receivers using one i-f stage or none at all, in which case the second detector usually is made regenerative.

Diodes make a practical second detector because they allow a simple method of obtaining automatic volume control to be used. Diodes load the tuned circuit to which they are connected, however, and thus reduce the selectivity slightly. Special i-f transformers are used for the purpose of providing a low-impedance input circuit to the diode detector.

Automatic Gain Control Modern receivers include a control loop to automatically adjust the r-f and i-f gain.

The loop holds the receiver output substantially constant despite changes in input signal level. This system is termed *automatic gain control* (agc) or automatic volume control (avc). In SSB receivers a d-c control voltage is derived from the composite signal, while in a-m reception, the carrier signal is rectified. The control voltage is applied to a variable gain element in the receiver, usually in the r-f and i-f chain.

The elements of a basic agc system suitable for a-m reception is shown in figure 29A.

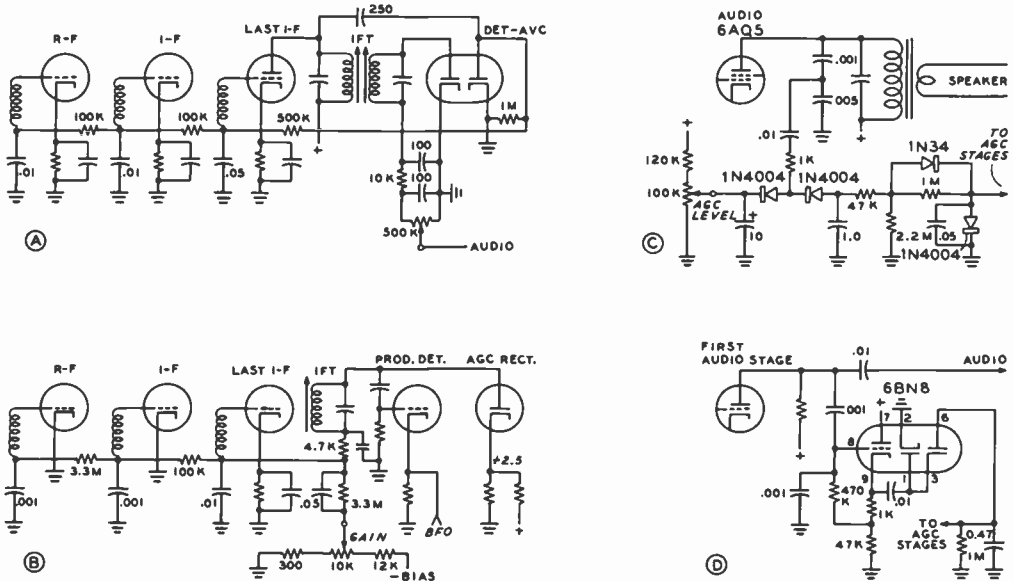

Figure 29

AGC CIRCUITS OF A-M AND SSB RECEIVERS

A—Diode avc circuit suitable for a-m reception. Right-hand diode rectifies carrier wave and delivers pulsating d-c control voltage to r-f and i-f amplifier stages. **B—**Product detector and agc system. Bfo voltage is isolated from agc system so that rectified oscillator voltage does not actuate agc loop. Initial gain level is set by gain potentiometer whose minimum voltage value may be adjusted to correspond to d-c bias level placed on agc rectifier. **C—**Audio-derived agc system is suitable for SSB reception. Agc level is set by potentiometer and system provides fast-attack, slow-release response. **D—**Audio agc signal is derived from low-level audio stage and applied to signal diodes through cathode follower. Action of system is similar to that of circuit C.

A dual-diode tube is used as a combination diode detector and avc rectifier. The left-hand diode operates as a simple rectifier in the manner described earlier in this chapter. Audio voltage, superimposed on a d-c voltage, appears across the 500,000-ohm potentiometer (the volume control) and the .0001- μ fd capacitor, and is passed on to the audio amplifier. The right-hand diode receives signal voltage directly from the primary of the last i-f amplifier, and acts as the avc rectifier. The pulsating d-c voltage across the 1-megohm avc-diode load resistor is filtered by a 500,000-ohm resistor and a .05- μ fd capacitor, and is applied as bias to the grids of the r-f and i-f amplifier tubes; an increase or decrease in signal strength will cause a corresponding increase or decrease in avc bias voltage, and thus the gain of the receiver is automatically adjusted to compensate for changes in signal strength.

A-C Loading of Second Detector By disassociating the avc and detecting functions through the use of separate diodes, as shown, most of the ill effects of *a-c shunt loading* on the detector diode are avoided. This type of loading causes serious distortion, and the additional components required to eliminate it are well worth their cost. Even with the circuit shown, a-c loading can occur unless a *very high* (5 megohms, or more) value of grid resistor is used in the following audio amplifier stage.

AVC in BFO Equipped Receivers In receivers having a beat-frequency oscillator for the reception of c-w or SSB signals, the use of an avc system such as shown in figure 29A can result in a great loss in sensitivity when the bfo is switched on. This is because the beat-oscillator output acts exactly like a strong

received signal, and causes the avc circuit to put high bias on the r-f and i-f stages, thus greatly reducing the receiver's sensitivity. Due to the above effect, it is necessary to either isolate the avc voltage or make the avc circuit inoperative when the bfo is being used. The simplest method of eliminating the avc action is to short the avc line to ground when the bfo is turned on. A two-circuit switch may be used for the dual purpose of turning on the beat oscillator and shorting out the avc if desired.

AGC for SSB Reception For optimum SSB reception, the control voltage must be applied rapidly to the variable

gain element to avoid transient overload at the beginning portion of each word, or an annoying *agc thump* will be apparent at the start of the first syllable. As the syllabic envelope of the SSB wave is a replica of the original audio signal, the *agc* voltage must rise rapidly with the start of the syllable and then hold at a value corresponding to the average of the syllabic undulations of the signal over an extended period of seconds. Too-rapid variation of the *agc* voltage with respect to syllabic peaks may bring up background noise in an objectionable manner, termed *agc pumping*. The ideal *agc* action, then, exhibits a fast-attack, slow-decay time constant, such as shown in figure 29B.

Since *agc* voltage follows the average SSB syllabic undulation of speech, it is possible to derive the *agc* voltage from the audio system of the receiver as shown in figures 29C and D. A portion of the audio signal is rectified and returned to the controlled stages after passing through a combination filtering and delay network.

Signal-Strength Indicators Visual means for determining whether or not the receiver is properly tuned, as

well as an indication of the relative signal strength, are both provided by means of *tuning indicators* (S meters). A d-c milliammeter can be connected in the plate-supply circuit of one or more r-f or i-f amplifiers, as shown in figure 30A, so that the change in plate current, due to the action of the avc voltage, will be indicated on the instrument. The d-c instrument (MA) should have a full-scale reading approxi-

mately equal to the total plate current taken by the stage or stages whose plate current passes through the instrument. The value of this current can be estimated by assuming a plate current on each stage (with no signal input to the receiver) of about 6 ma. However, it will be found to be more satisfactory to measure the actual plate current on the stages with a milliammeter of perhaps 0-100 ma full scale before purchasing an instrument for use as an S meter. The 50-ohm potentiometer shown in the drawing is used to adjust the

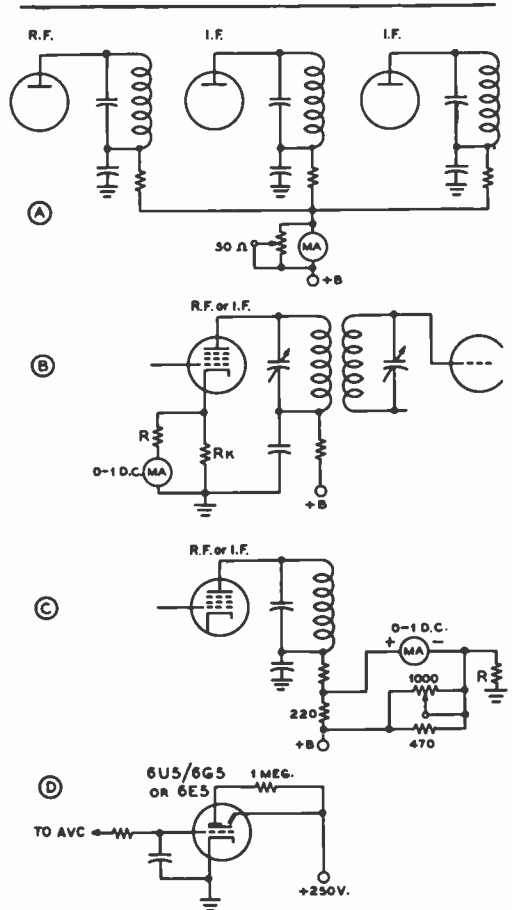

Figure 30

SIGNAL-STRENGTH METER CIRCUITS

Shown above are four circuits for obtaining a signal-strength reading which is a function of incoming carrier amplitude. The circuits are discussed in the accompanying text.

meter reading to full scale with no signal input to the receiver.

When an ordinary meter is used in the plate circuit of a stage, for the purpose of indicating signal strength, the meter reads backwards with respect to strength. This is because increased AVC bias on stronger signals causes lower plate current through the meter.

The circuit of figure 30B can frequently be used to advantage in a receiver where the cathode of one of the r-f or i-f amplifier stages runs directly to ground through the cathode-bias resistor instead of running through a cathode-voltage gain control. In this case a 0-1 d-c milliammeter in conjunction with a resistor of 1000 to 3000 ohms can be used as shown as a signal-strength meter. With this circuit the meter will read backwards with increasing signal strength as in the circuit previously discussed.

Figure 30C is the circuit of a forward-reading S meter often used in communications receivers. The instrument is used in an unbalanced bridge circuit with the d-c plate resistance of one i-f tube as one leg of the bridge and with resistors for the other three legs. The value of resistor R must be determined by trial and error and will be somewhere in the vicinity of 50,000 ohms. Sometimes the screen circuits of the r-f and i-f stages are taken from this point along with the screen-circuit voltage divider.

Audio Amplifiers Audio amplifiers are employed in nearly all radio receivers. The purpose of the audio amplifier is to bring the relatively weak signal from the detector up to a strength sufficient to operate a pair of headphones or a loudspeaker. Either triodes, pentodes, or beam tetrodes may be used, the pentodes and beam tetrodes usually giving greater output.

Most communications receivers, either home-constructed or factory-made, have a single-ended beam tetrode such as a 6V6 or 6AQ5 in the audio output stage feeding the speaker. If precautions are not taken such a stage will actually bring about a decrease in the effective signal-to-noise ratio of the receiver due to the rising high-frequency characteristic of such a stage when feeding a speaker. One way of improving this condition is to place a mica or paper capacitor of

approximately 0.003 μ fd capacitance across the primary of the output transformer. The use of a capacitor in this manner tends to make the load impedance seen by the plate of the output tube more constant over the audio-frequency range. The speaker and transformer will tend to present a rising impedance to the tube as the frequency increases, and the parallel capacitor will tend to make the total impedance more constant since it will tend to present a decreasing impedance with increasing audio frequency.

10-9 Noise Suppression

The problem of noise suppression confronts the listener who is located in places where interference from power lines, electrical appliances, and automobile ignition systems is troublesome. This noise is often of such intensity as to swamp out signals from desired stations.

There are two principal methods for reducing this noise. They are:

- (1) a-c line filters at the source of interference, if the noise is created by an electrical appliance; and
- (2) noise-limiting circuits for the reduction, in the receiver itself, of interference of the type caused by automobile ignition systems.

Power Line Filters Many household appliances, such as electric mixers, heating pads, vacuum cleaners, refrigerators, oil burners, sewing machines, doorbells, etc., create an interference of an intermittent nature. The insertion of a line filter near the source of interference often will effect a complete cure. Filters for small appliances can consist of a 0.1- μ fd capacitor connected across the 120-volt a-c line. Two capacitors in series across the line, with the midpoint connected to ground, can be used in conjunction with industrial heating machines, refrigerators, oil-burner furnaces, and other more stubborn offenders. In severe cases of interference, additional filters in the form of heavy-duty r-f choke coils must be connected in series with the 120-volt a-c line on both sides of the line right at the interfering appliance.

Peak Noise Limiters Numerous noise-limiting circuits which are beneficial in overcoming key clicks, automobile ignition interference, and similar noise impulses have become popular. They operate on the principle that each individual noise pulse is of very short duration, yet of very high amplitude. The popping or clicking type of noise from electrical ignition systems may produce a signal having a peak value ten to twenty times as great as the incoming radio signal, but an average power much less than the signal.

As the duration of this type of noise peak is short, the receiver can be made inoperative during the noise pulse without the human ear detecting the total loss of signal. Some noise limiters actually *punch a hole* in the signal while others merely *limit* the maximum peak signal which reaches the headphones or speaker.

The noise peak is of such short duration that it would not be objectionable except for the fact that it produces an overloading effect on the receiver, which increases its time constant. A sharp voltage peak will give a kick to the diaphragm of the headphones or speaker, and the momentum or inertia keeps the diaphragm in motion until the damping of the diaphragm stops it. This movement produces a popping sound which may completely obliterate the desired signal. If the noise pulse can be limited to a peak amplitude equal to that of the desired signal, the resulting interference is practically negligible for moderately low repetition rates, such as ignition noise.

In addition, the i-f amplifier of the receiver will also tend to lengthen the duration of the noise pulses because the relatively high- Q i-f tuned circuits will *ring* or oscillate when excited by a sharp pulse, such as is produced by ignition noise. The most effective noise limiter would be placed before the high- Q i-f tuned circuits. At this point the noise pulse is the sharpest and has not been degraded by passage through the i-f transformers. In addition, the pulse is eliminated before it can produce ringing effects in the i-f chain.

The Lamb Noise Limiter An i-f noise limiter is shown in figure 31. This is an adaptation of the *Lamb* noise silencer circuit. The i-f signal is fed into a

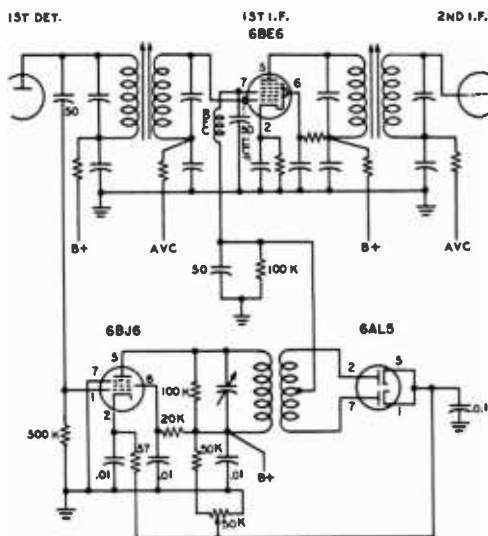

Figure 31

THE LAMB I-F NOISE SILENCER

double-grid tube, such as a 6BE6, and thence into the i-f chain. A 6BJ6 high-gain pentode is capacity coupled to the input of the i-f system. This auxiliary tube amplifies both signal and noise that is fed to it. It has a maximum of selectivity ahead of it so that it receives the true noise pulse before it is degraded by the i-f strip. A broadly tuned i-f transformer is used to couple the noise amplifier to a 6AL5 noise rectifier. The gain of the noise amplifier is controlled by a potentiometer in the cathode of the 6BJ6 noise amplifier. This potentiometer controls the gain of the noise amplifier stage and in addition sets the bias level on the 6AL5 diode so that the incoming signal will not be rectified. Only noise peaks louder than the signal can overcome the resting bias of the 6AL5 and cause it to conduct. A noise pulse rectified by the 6AL5 is applied as a negative voltage to the control grid of the 6BE6 i-f tube, disabling the tube, and punching a hole in the signal at the instant of the noise pulse. By varying the bias control of the noise limiter, the negative control voltage applied to the 6BE6 may be adjusted until it is barely sufficient to overcome the noise impulses applied to the #1 control grid without allowing the modulation peaks of the carrier to become badly distorted.

The Bishop Noise Limiter Another effective i-f noise limiter is the *Bishop* limiter.

This is a full-wave shunt type diode limiter applied to the primary of the last i-f transformer of a receiver. The limiter is self-biased and automatically adjusts itself to the degree of modulation of the received signal. The schematic of this limiter is shown in figure 32. The bias-circuit time constant is determined by C_1 and the shunt resistance, which consists of R_1 and R_2 in series. The plate resistance of the last i-f tube and the capacity of C_1 determine the charging rate of the circuit. The limiter is disabled by opening S_1 , which allows the bias to rise to the value of the i-f signal.

Audio Noise Limiters Some of the simplest and most practical peak limiters for radiotelephone reception employ

one or two diodes either as shunt or series limiters in the audio system of the receiver. When a noise pulse exceeds a certain predetermined threshold value, the limiter diode acts either as a short or open circuit, depending on whether it is used in a shunt or series circuit. The threshold is made to occur at a level high enough that it will not clip modulation peaks enough to impair voice intelligibility, but low enough to limit the noise peaks effectively.

Because the action of the peak limiter is needed most on very weak signals, and these usually are not strong enough to produce proper avc action, a threshold setting that is correct for a strong phone signal is not correct for optimum limiting on very weak signals. For this reason the threshold control is often tied in with the avc system so as to make the optimum threshold adjustment automatic instead of manual.

Suppression of impulse noise by means of

an audio peak limiter is best accomplished at the very front end of the audio system, and for this reason the function of a superheterodyne second detector and limiter often are combined in a composite circuit.

The amount of limiting that can be obtained is a function of the audio distortion that can be tolerated. Because excessive distortion will reduce the intelligibility as much as will background noise, the degree of limiting for which the circuit is designed has to be a compromise.

Peak noise limiters working at the second detector are much more effective when the i-f bandwidth of the receiver is broad, because a sharp i-f amplifier will lengthen the pulses by the time they reach the second detector, making the limiter less effective. Vhf superheterodynes have an i-f bandwidth considerably wider than the minimum necessary for voice sidebands (to take care of drift and instability). Therefore, they are capable of better peak noise suppression than a standard communications receiver having an i-f bandwidth of perhaps 8 kHz. Likewise, when a crystal filter is used on the "sharp" position an a-f peak limiter is of little benefit.

Practical Peak Noise Limiter Circuits Noise limiters range all the way from an audio stage running at very low screen or plate voltage, to elaborate affairs employing 5 or more tubes. Rather than attempt to show the numerous types, many of which are quite complex considering the results obtained, only two very similar types will be described. Either is just about as effective as the most elaborate limiter that can be constructed, yet requires the addition of but a single diode and a few resistors and capacitors over what would be employed in a good superheterodyne without a limiter. Both circuits, with but minor modifications in resistance and capacitance values, are incorporated in one form or another in different types of factory-built communications receivers.

Referring to figure 33, the first circuit shows a conventional superheterodyne second detector, avc, and first audio stage with the addition of one tube element (D_3) which may be either a separate diode or part of a twin-diode as illustrated. Diode D_3 acts as a

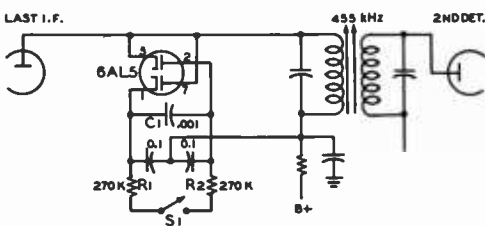

Figure 32

THE BISHOP I-F NOISE LIMITER

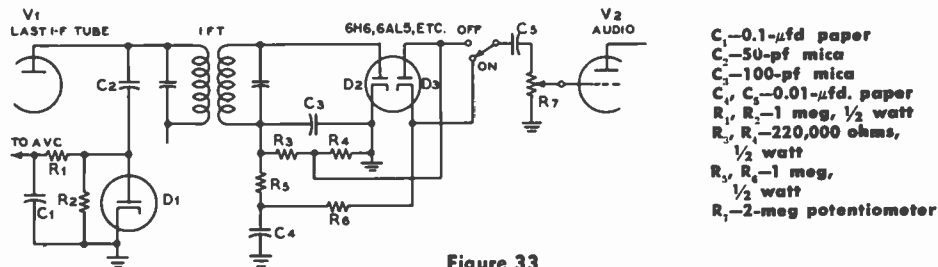

Figure 33

NOISE LIMITER CIRCUIT, WITH ASSOCIATED AVC

This limiter is of the series type, and is self-adjusting to carrier strength for phone reception. For proper operation several volts should be developed across the secondary of the last i-f transformer (IFT) under carrier conditions.

series gate, allowing audio to reach the grid of the a-f tube only so long as the diode is conducting. The diode is biased by a d-c voltage obtained in the same manner as avc control voltage, the bias being such that pulses of short duration no longer conduct when the pulse voltage exceeds the carrier by approximately 60 percent. This also clips voice modulation peaks, but not enough to impair intelligibility.

It is apparent that the series diode clips only *positive* modulation peaks, by limiting upward modulation to about 60 percent. Negative or downward peaks are limited automatically to 100 percent in the detector, because obviously the rectified voltage out of the diode detector cannot be less than zero.

It is important that the exact resistance values shown be used, for best results, and that 10-percent tolerance resistors be used for R₃ and R₄. Also, the rectified carrier voltage developed across C₃ should be at least 5 volts for good limiting.

The limiter will work well on c-w and SSB if the amplitude of beat-frequency oscillator injection is not too high. Variable injection is to be preferred, adjustable from the front panel. If this feature is not provided, the bfo injection should be reduced to the lowest value that will give a satisfactory beat.

Alternative Limiter Circuit The circuit of figure 34 is more effective than that shown in figure 33 under certain conditions and requires the addition of only one more resistor and one more capacitor than the other circuit. Also, this circuit involves a smaller loss in output level than

the circuit of figure 30. This circuit can be used with equal effectiveness with a combined diode-triode or diode-pentode tube (6AT6, 6BN8, 6FM8, or similar diode-triodes, or 6AS8, 6CR6, 6BW8, or similar diode-pentodes) as diode detector and first audio stage. However, a separate diode must be used for the noise limiter (D₂). This diode may be one-half of a 6H6, or 6AL5, etc.; it may be a triode connected 6J5, 6C4, or similar type, or it may be a high back-resistance diode (1N658), or equivalent.

Note that the return for the volume control must be made to the cathode of the detector diode (and not to ground) when a dual tube is used as combined second-detector first-audio. This means that in the circuit shown in figure 34 a connection will exist across the points where the "X" is shown on the diagram since a common cathode lead is brought out of the tube for D₁ and V₁. If desired, of course, a single dual diode may be used for D₁ and D₂ in this circuit as well as in the circuit of figure 30. Switching the limiter in and out with the switch S brings about no change in volume.

The Full-Wave Limiter The most satisfactory diode noise limiter is the series full-wave limiter, shown in figure 35. The positive noise peaks are clipped by diode A, the clipping level of which may be adjusted to clip at any modulation level between 25 and 100 percent. The negative noise peaks are clipped by the right-hand diode at a fixed level.

The TNS Limiter The *Twin Noise Squelch*, is a combination of a diode

This circuit is of the self-adjusting type and gives less distortion for a given degree of modulation than the more common limiter circuits.

R_1, R_2 —470K, ½ watt
 R_3 —100K, ½ watt
 R_4, R_5 —1 meg, ½ watt
 R_6 —2-meg potentiometer
 C_1 —0.00025 mica (approx.)
 C_2 —0.01- μ fd paper
 C_3 —0.01- μ fd paper
 C_4 —0.01- μ fd paper
 D_1, D_2 —6H6, 6AL5, diode sections of a 6AT6, or crystal diodes.

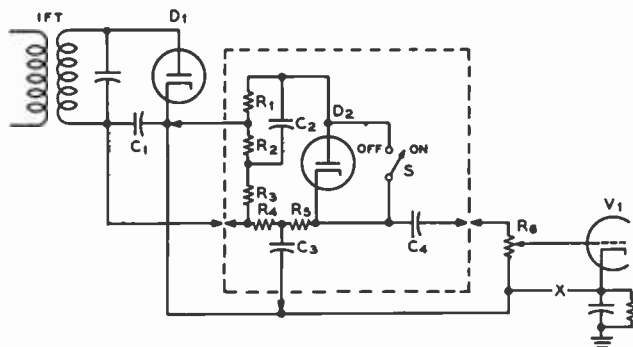

Figure 34

ALTERNATIVE NOISE LIMITER CIRCUIT

noise clipper and an audio squelch tube. The squelch circuit is useful in eliminating the grinding background noise that is the residual left by the diode clipper. In figure 36, the setting of the 470K potentiometer determines the operating level of the squelch action and should be set to eliminate the residual background noise. Because of the low inherent distortion of the TNS, it may be left in the circuit at all times. As with other limiters, the TNS requires a high signal level at the second detector for maximum limiting effect.

Noise Blanker The *noise blanker* (figure 37) employs the i-f signal to drive blanking diodes which short out one or more of the tuned circuits in the i-f system, much in the manner of the Bishop limiter. Impulse noise entering the high-selectivity portion of a receiver causes pulse stretching (ringing) which makes weak-signal reception difficult. Reduction of impulse noise prior to amplification by high-selectivity circuits is desired for effective noise suppression.

In vhf receiving systems utilizing converters, it is possible to place the noise-suppression system between the converter and the receiver for effective blanking action. Junction field-effect (JFET) transistors may be used in order to reduce cross-modulation from strong signals and to provide the greatest dynamic blanking range.

Several stages of amplification are used to provide high-amplitude, squared noise pulses which cause the blanking diodes

($CR_{1,2}$) to conduct, thus disabling the tuned circuits of the i-f amplifier. Input level to the blanker is adjusted by varying the capacitor in the base circuit of the first transistor.

10-10 Special Considerations in UHF Receiver Design

Transmission Line Circuits At increasingly higher frequencies, it becomes progressively more difficult to obtain a satisfactory amount of selectivity and impedance from an ordinary coil and capacitor used as a resonant circuit. On the other hand, quarter-wavelength sections of parallel conductors or concentric transmission line are not only more efficient but also approach practical dimensions.

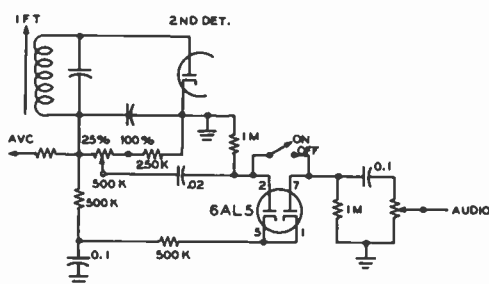

Figure 35

THE FULL-WAVE SERIES AUDIO NOISE LIMITER

Tuning Short Lines Tubes and tuning capacitors connected to the open end of a transmission line provide a capacitance that makes the resonant length less than a quarter wavelength. The amount of shortening for a specified capacitive reactance is determined by the surge impedance of the line section. It is given by the equation for resonance:

$$\frac{1}{2\pi fC} = Z_0 \tan l$$

where,

- π equals 3.1416,
- f equals the frequency,
- C equals the capacitance,
- Z_0 equals the surge impedance of the line,
- $\tan l$ equals the tangent of the electrical length in degrees.

The capacitive reactance of the capacitance across the end is $1/(2\pi fC)$ ohms. For resonance, this must equal the surge impedance of the line times the tangent of its electrical length (in degrees, where 90° equals a quarter wave). It will be seen that twice the capacitance will resonate a line if its surge impedance is halved; also that a given capacitance has twice the loading effect when the frequency is doubled.

Coupling Into Lines and Coaxial Circuits It is possible to couple into a parallel-rod line by tapping directly on one or both rods, preferably through blocking capacitors if any d.c. is present. More commonly, however, a *hairpin* is induc-

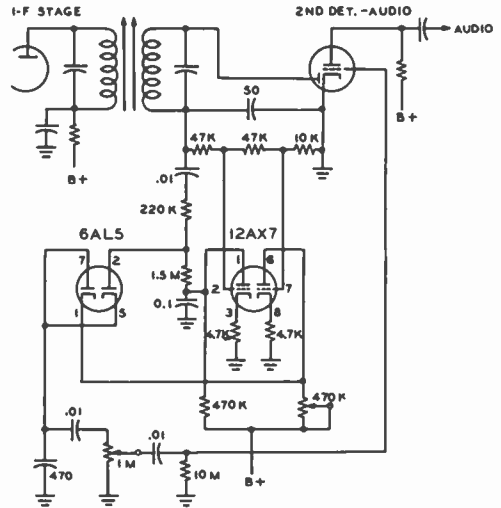

Figure 36

THE TNS AUDIO NOISE LIMITER

tively coupled at the shorting-bar end, either to the bar or to the two rods, or both. This normally will result in a balanced load. Should a loop unbalanced to ground be coupled in, any resulting unbalance reflected into the rods can be reduced with a simple Faraday screen, made of a few parallel wires placed between the hairpin loop and the rods. These should be soldered at only one end and grounded.

An unbalanced tap on a coaxial resonant circuit can be made directly on the inner conductor at the point where it is properly matched (figure 38). For low impedances, such as a concentric-line feeder, a small one-half turn loop can be inserted through a hole in the outer conductor of the coaxial circuit, being in effect a half of the hairpin type recommended for coupling balanced feeders to coaxial resonant lines. The size of the loop and closeness to the inner conductor determines the impedance matching and loading. Such loops coupled in near the shorting disc do not alter the tuning appreciably, if they are not overcoupled.

Resonant Cavities A cavity is a closed resonant chamber made of metal. The cavity, having both inductance and capacitance, supersedes coil-capacitor and capacitance loaded transmission-line tuned circuits at extremely high frequencies where

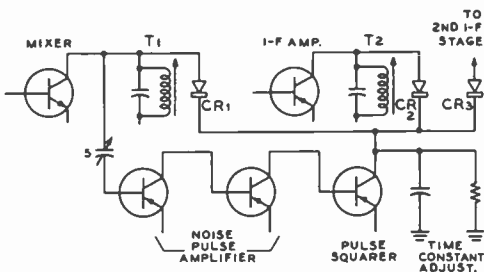

Figure 37

NOISE BLANKER FOR I-F SYSTEM

Noise blanker employs i-f signal to drive blanking diodes (CR₁, CR₂) which short out one or more tuned circuits in the i-f amplifier. Impulse noise is amplified and processed to provide optimum blanking signal to diodes.

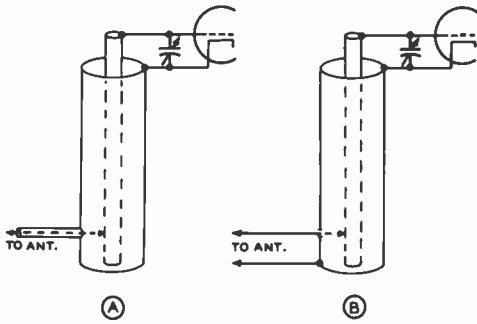

Figure 38

COUPLING AN ANTENNA TO A COAXIAL RESONANT CIRCUIT

A shows the recommended method for coupling a coaxial line to a coaxial resonant circuit. B shows an alternative method for use with an open-wire type of antenna feed line.

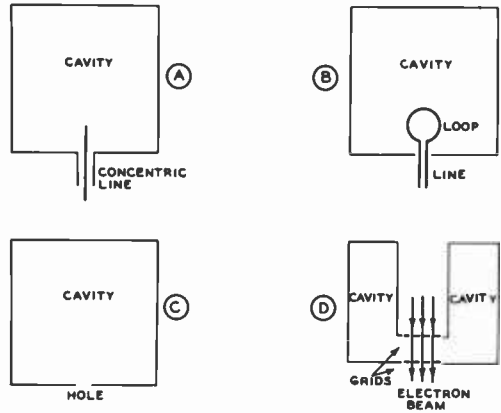

Figure 39

METHODS OF EXCITING A RESONANT CAVITY

conventional L and C components, of even the most refined design, prove impractical because of the tiny electrical and physical dimensions they must have. Microwave cavities have high Q factors and are superior to conventional tuned circuits. They may be employed in the manner of an absorption wavemeter or as the tuned circuit in other r-f test instruments, and in microwave transmitters and receivers.

Resonant cavities usually are closed on all sides and all of their walls are made of conducting material. However, in some forms, small openings are present for the purpose of excitation (figure 39).

Cavities have been produced in several shapes including the plain sphere, dimpled sphere, sphere with re-entrant cones of various sorts, cylinder, prism (including

cube), ellipsoid, ellipsoid-hyperboloid, doughnut-shape, and various re-entrant types. In appearance, they resemble in their simpler forms metal boxes or cans.

The cavity actually is a linear circuit, but one which is superior to a conventional coaxial resonator in the uhf range. The cavity resonates in much the same manner as does a barrel or a closed room with reflecting walls.

Because electromagnetic energy (and the associated electrostatic energy) oscillates to and fro inside them in one mode or another, resonant cavities resemble waveguides. The mode of operation in a cavity is affected by the manner in which microwave energy is injected. A cavity will resonate to a large number of frequencies, each being associated

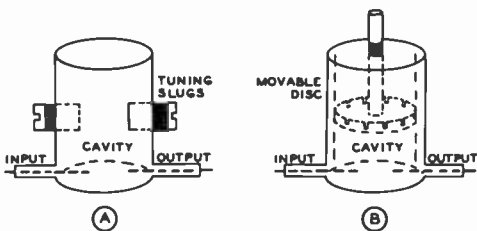

Figure 40

TUNING METHODS FOR CYLINDRICAL RESONANT CAVITIES

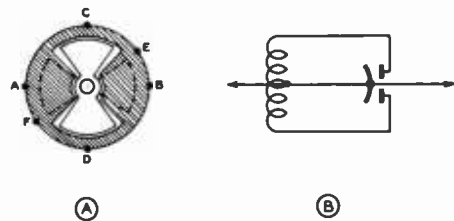

Figure 41

THE BUTTERFLY RESONANT CIRCUIT

Shown at A is the physical appearance of the butterfly circuit as used in the vhf and lower uhf range. B shows an electrical representation of the circuit.

with a particular mode or standing-wave pattern. The lowest mode (lowest frequency of operation) of a cavity resonator normally is the one used.

The resonant frequency of a cavity may be varied, if desired, by means of movable plungers or plugs, as shown in figure 40A, or a movable metal disc (figure 40B). A cavity that is too small for a given wavelength will not oscillate.

The resonant frequencies of simple spherical, cylindrical, and cubical cavities may be calculated simply for one particular mode. Wavelength and cavity dimensions (in centimeters) are related by the following simple resonance formulas:

- for cylinder $\lambda_r = 2.6 \times \text{radius}$;
- for cube $\lambda_r = 2.83 \times \text{half of 1 side}$;
- for sphere $\lambda_r = 2.28 \times \text{radius}$.

Butterfly Circuit Unlike the cavity resonator, which in its conventional form is a device which can tune over a relatively narrow band, the *butterfly circuit* is a tunable resonator which permits coverage of a fairly wide uhf band. The butterfly circuit is very similar to a conventional coil/variable-capacitor combination, except that both inductance and capacitance are provided by what appears to be a variable capacitor alone. The Q of this device is somewhat less than that of a concentric-line tuned circuit but is entirely adequate for numerous applications.

Figure 41A shows construction of a single butterfly section. The butterfly-shaped rotor, from which the device derives its name, turns in relation to the unconventional stator. The two groups of stator "fins" or sectors are in effect joined together by a semicircular metal band, integral with the sectors, which provides the circuit inductance. When the rotor is set to fill the loop opening (the position in which it is shown in figure 41A), the circuit inductance and capacitance are reduced to minimum. When the rotor occupies the position indicated by the dotted lines, the inductance and capacitance are at maximum. The tuning range of practical butterfly circuits is in the ratio of 1.5:1 to 3.5:1.

Direct circuit connections may be made to points A and B. If balanced operation is desired, either point C or D will provide the

electrical midpoint. Coupling may be effected by means of a small single-turn loop placed near point E or F. The butterfly thus permits continuous variation of both capacitance and inductance, as indicated by the equivalent circuit in figure 41B, while at the same time eliminating all pigtailed and wiping contacts.

Butterfly circuits have been applied specifically to oscillators for transmitters, superheterodyne receivers, and heterodyne frequency meters in the 100- to 1000-MHz frequency range.

Receiver Circuits The types of resonant circuits described in the previous paragraphs have largely replaced conventional coil-capacitor circuits in the range above 200 MHz. Tuned short lines and butterfly circuits are used in the range from about 200 MHz to perhaps 3500 MHz, and above about 3500 MHz resonant cavities are used almost exclusively. The resonant cavity is also quite generally employed in the 2000- to 3500-MHz range.

VHF Tubes and Transistors In a properly designed receiver, thermal agitation in the first tuned circuit is amplified by subsequent tubes or transistors and predominates in the output. For good signal-to-set-noise ratio, therefore, one must strive for a high-gain low-noise r-f stage. Hiss can be held down by giving careful attention to this point. A mixer has about 0.3 the gain of an r-f tube or transistor of the same type; so it is advisable to precede a mixer by an efficient r-f stage. It is also of some value to have good r-f selectivity before the first mixer in order to reduce noises produced by beating noise at one frequency against noise at another, to produce noise at the intermediate frequency in a superheterodyne.

The frequency limit of a tube or transistor is reached when the shortest possible external connections are used as the tuned circuit, except for abnormal types of oscillation. Wires or sizable components are often best considered as sections of transmission lines rather than as simple resistances, capacitances, or inductances.

Tubes employing the conventional grid-controlled and diode rectifier principles have been modernized, through various expedients,

for operation at frequencies as high, in some new types, as 4000 MHz. Beyond that frequency, electron transit time becomes the limiting factor and new principles must be enlisted. In general, the improvements embodied in existing tubes have consisted of (1) reducing electrode spacing to cut down electron transit time, (2) reducing electrode areas to decrease interelectrode capacitances, and (3) shortening of electrode leads either by mounting the electrode assembly close to the tube base or by bringing the leads out directly through the glass envelope at nearby points. Through reduction of lead inductance and interelectrode capacitances, input and output resonant frequencies due to tube construction have been increased substantially.

Tubes embracing one or more of the features just outlined include the later loctal types, high-frequency acorns, button-base types, and the lighthouse types. The button-base triode and the 6CW4 *Nuvistor* will reach 500 MHz.

VHF Transistors The general use of transistorized tuners in color TV receivers has led to the development of low-noise, high-gain transistors, suitable for use up to 1 GHz, or beyond. When used in the recommended circuitry, noise figures are typically: 200 MHz—2.4; 450 MHz—3.5 and 1 GHz—6.5. In amateur work, transistors have largely replaced tubes for low-noise reception above 144 MHz.

Germanium Rectifiers Small germanium semiconductors are employed as detector and mixer elements in receivers and test instruments used at extremely high radio frequencies. The chief advantages of the germanium diode are very low capacitance, relative freedom from transit time difficulties, and its two-terminal nature. The diode consists of a small piece of germanium mounted in a base of low-melting-point alloy and contacted by means of a thin, springy wire (figure 42).

The complex physics of solid-state rectification is beyond the scope of this discussion, but it is sufficient to state that current flows from several hundred to several thousand times more readily in one direction through the diode than in the opposite direction. Consequently, an alternating current (including one of microwave fre-

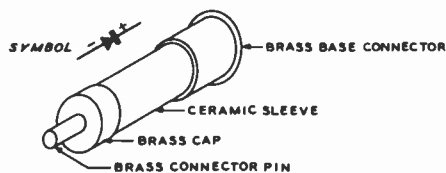

Figure 42

1N23 MICROWAVE-TYPE CRYSTAL DIODE

A small silicon crystal is attached to the base connector and a fine feeler wire is set to the most sensitive spot on the crystal. After adjustment the ceramic shell is filled with compound to hold the contact wire in position. Crystals of this type are used to over 30,000 MHz.

quency) will be rectified by the diode. The load, through which the rectified current flows, may be connected in series or shunt with the diode.

10-11 Receiver Adjustment

A simple regenerative receiver requires little adjustment other than that necessary to ensure correct tuning and smooth regeneration over some desired range. Receivers of the tuned-radio-frequency type and superheterodynes require precise alignment to obtain the highest possible degree of selectivity and sensitivity.

Good results can be obtained from a receiver only when it is properly aligned and adjusted. The most practical technique for making these adjustments is given below.

Instruments A very small number of instruments will suffice to check and align a communications receiver, the most important of these testing units being a modulated oscillator and a d-c and a-c voltmeter. The meters are essential in checking the voltage applied at each circuit point from the power supply. If the a-c voltmeter is of the oxide-rectifier type, it can be used, in addition, as an output meter when connected across the receiver output when tuning to a modulated signal. If the signal is a steady tone, such as from a test oscillator, the output meter will indicate the value of the detected signal. In this manner, alignment results may be visually noted on the meter.

TRF Receiver Alignment Alignment procedure in a multistage trf receiver is exactly the same as aligning a single stage. If the detector is regenerative, each preceding stage is successively aligned while keeping the detector circuit tuned to the test signal, the latter being a station signal or one locally generated by a test oscillator loosely coupled to the antenna lead. During these adjustments, the r-f amplifier gain control is adjusted for maximum sensitivity, assuming that the r-f amplifier is stable and does not oscillate. Often a sensitive receiver can be roughly aligned by tuning for maximum noise pickup.

Superheterodyne Alignment Aligning a superhet is a detailed task requiring a great amount of care and patience. It should never be undertaken without a thorough understanding of the involved job to be done and then only when there is abundant time to devote to the operation. There are no shortcuts; every circuit must be adjusted individually and accurately if the receiver is to give peak performance. The precision of each adjustment is dependent on the accuracy with which the preceding one was made.

Superhet alignment requires (1) a good signal generator (modulated oscillator) covering the radio and intermediate frequencies and equipped with an attenuator; (2) the necessary socket wrenches, screwdrivers, or "neutralizing tools" to adjust the various i-f and r-f trimmer capacitors; and (3) some convenient type of tuning indicator, such as a copper-oxide or electronic voltmeter.

Throughout the alignment process, unless specifically stated otherwise, the r-f gain control must be set for maximum output, the beat oscillator switched off, and the AVC turned off or shorted out. When the signal output of the receiver is excessive, either the attenuator or the a-f gain control may be turned down, but never the r-f gain control.

I-F Alignment After the receiver has been given a rigid electrical and mechanical inspection, and any faults which may have been found in wiring or the selection and assembly of parts are corrected, the i-f amplifier may be aligned as the first step in the checking operations.

With the signal generator set to give a

modulated signal on the frequency at which the i-f amplifier is to operate, clip the "hot" output lead from the generator through a small fixed capacitor to the control grid of the last i-f tube. Adjust both trimmer capacitors in the last i-f transformer (the one between the last i-f amplifier tube and the second detector) to resonance as indicated by maximum deflection of the output meter.

Each i-f stage is adjusted in the same manner, moving the hot lead, stage by stage, back toward the front end of the receiver and backing off the attenuator as the signal strength increases in each new position. The last adjustment will be made to the first i-f transformer, with the hot signal generator lead connected to the control grid of the mixer. Occasionally it is necessary to disconnect the mixer grid lead from the coil, grounding it through a 1000- or 5000-ohm resistor, and then couple the signal generator through a small capacitor to the grid.

When the last i-f adjustment has been completed, it is good practice to go back through the i-f channel, re-peaking all of the transformers. It is imperative that this recheck be made in sets which do not include a crystal filter, and where the simple alignment of the i-f amplifier to the generator is final.

I-F with Crystal Filter There are several ways of aligning an i-f channel which contains a crystal-filter circuit.

However, the following method is one which has been found to give satisfactory results in every case: An unmodulated signal generator capable of tuning to the frequency of the filter crystal in the receiver is coupled to the grid of the stage which precedes the crystal filter in the receiver. Then, with the crystal filter switched in, the signal generator is tuned *slowly* to find the frequency where the crystal peaks. The receiver "S" meter may be used as the indicator, and the sound heard from the speaker will be of assistance in finding the point. When the frequency at which the crystal peaks has been found, all the i-f transformers in the receiver should be touched up to peak at that frequency.

BFO Adjustment Adjusting the beat oscillator on a receiver that has no front-panel adjustment is relatively sim-

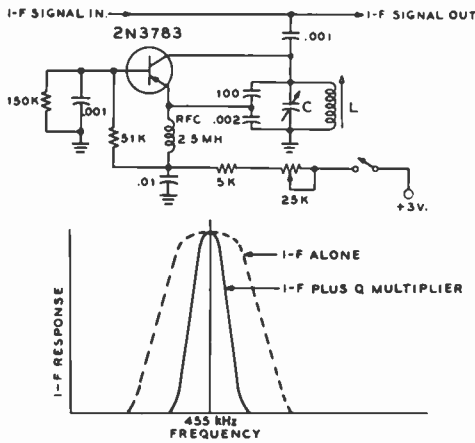

Figure 43

The Q-MULTIPLIER

The loss resistance of a high-Q circuit is neutralized by regeneration in a simple feedback amplifier. A highly selective passband is produced which is coupled to the i-f circuit of the receiver.

ple. It is only necessary to tune the receiver to resonance with any signal, as indicated by the tuning indicator, and then turn on the bfo and set its trimmer (or trimmers) to produce the desired beat note. Setting the beat oscillator in this way will result in the beat note being stronger on one "side" of the signal than on the other, which is what is desired for c-w reception. The bfo should *not* be set to *zero beat* when the receiver is tuned to resonance with the signal, as this will cause an equally strong beat to be obtained on both sides of resonance.

Front-End Alignment Alignment of the front end of a home-constructed receiver is a relatively simple process, consist-

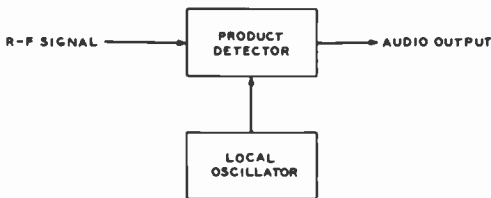

Figure 44

THE PRODUCT DETECTOR

Audio output signal is developed only when local oscillator is on.

ing of first getting the oscillator to cover the desired frequency range and then of peaking the various r-f circuits for maximum gain. However, if the frequency range covered by the receiver is very wide a fair amount of cut and try will be required to obtain satisfactory tracking between the r-f circuits and the oscillator. Manufactured communications receivers should always be tuned in accordance with the instructions given in the maintenance manual.

10-12 Receiving Accessories

The Q-Multiplier The selectivity of a receiver may be increased by raising the *Q* of the tuned circuits of the i-f strip. A simple way to accomplish this is to add a controlled amount of positive feedback to a tuned circuit, thus increasing its *Q*. This is done in the *Q-multiplier*, whose basic circuit is shown in figure 43. The circuit L-C₁-C₂ is tuned to the intermediate frequency, and the loss resistance of the circuit is neutralized by the positive-feedback circuit composed of C₃ and the vacuum tube. Too great a degree of positive feedback will cause the circuit to break into oscillation.

At the resonant frequency, the impedance of the tuned circuit is very high, and when shunted across an i-f stage will have little effect upon the signal. At frequencies removed from resonance, the impedance of the circuit is low, resulting in high attenuation of the i-f signal. The resonant frequency of the *Q*-multiplier may be varied by changing the value of one of the components in the tuned circuit.

The Product Detector A version of the common mixer or converter stage may be used as a second detector in a receiver in place of the usual diode detector. The diode is an envelope detector (section 12-1) and develops a d-c output voltage from a single r-f signal, and audio "beats" from two or more input signals. A *product detector* (figure 44) requires that a local carrier voltage be present in order to produce an audio output signal. Such a detector is useful for single-sideband work,

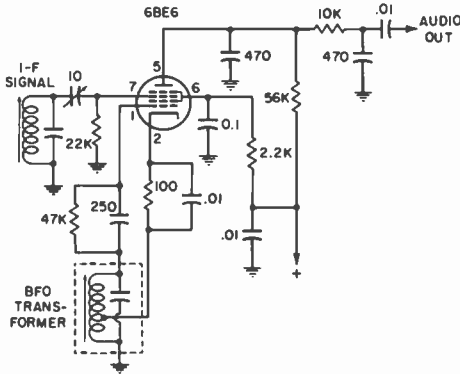

Figure 45

COMBINED BEAT OSCILLATOR AND PRODUCT DETECTOR

The variable i-f coupling capacitor is adjusted to provide approximately 0.2 volt peak signal at pin 7 of the 6BE6.

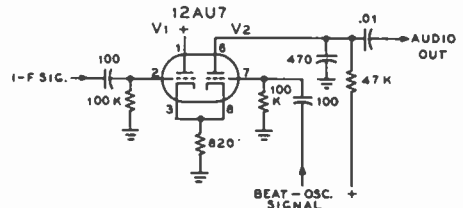

Figure 46

DOUBLE-TRIODE PRODUCT DETECTOR

since the intermodulation distortion is extremely low.

A pentagrid product detector is shown in figure 45. The incoming signal is applied to grid 3 of the mixer tube, and the local oscillator is injected on grid 1. Grid bias is adjusted over the linear portion of the tube-characteristic curve. When grid-1 injection is removed, the audio output from an unmodulated signal applied to grid 3 should be reduced approximately 30 to 40 db below normal detection level. When the frequency of the local oscillator is synchronized with the incoming carrier, amplitude-modulated signals may be received by *exalted-carrier* reception, wherein the local carrier substitutes for the transmitted carrier of the a-m signal.

A different version of the product detector is illustrated in figure 46. A twin-triode tube is used. Section V₁ functions as a cathode-follower amplifier. Section V₂ is a "plate" detector, the cathode of which is common with the cathode-follower amplifier. The local-oscillator signal is injected into the grid circuit of tube V₂.

Figure 47 shows solid-state product detectors employing switching diodes driven by voltage from a local bfo.

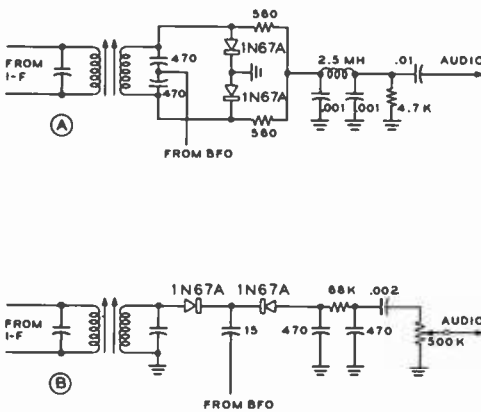

Figure 47

SOLID-STATE PRODUCT DETECTOR

Switching diodes driven by bfo signal provide effective product detector.

Generation of Radio-Frequency Energy

A radio communication or broadcast transmitter consists of a source of radio frequency power, or *carrier*; a system for *modulating* the carrier whereby voice or telegraph keying or other modulation is superimposed upon it; and an antenna system, including feedline, for *radiating* the intelligence-carrying radio-frequency power. The power supply employed to convert primary power to the various voltages required by the r-f and modulator portions of the transmitter may also be considered part of the transmitter.

Voice modulation usually is accomplished by varying either the amplitude or the frequency of the radio-frequency carrier in accord with the components of intelligence to be transmitted or by generation of an SSB signal.

Radiotelegraph modulation (keying) normally is accomplished either by interrupting, shifting the frequency of, or superimposing an audio tone on the radio-frequency carrier in accordance with the dots and dashes to be transmitted.

The complexity of the radio-frequency generating portion of the transmitter is dependent on the power, order of stability, and frequency desired. An oscillator feeding an antenna directly is the simplest form of

radio-frequency generator. A modern high-frequency transmitter, on the other hand, is a very complex generator. Such equipment comprises a very stable crystal-controlled or self-controlled oscillator to stabilize the output frequency, a series of frequency multipliers, or mixers, one or more amplifier stages to increase the power up to the level which is desired for feeding the antenna system, and a filter system for keeping the harmonic energy generated in the transmitter from being fed to the antenna system.

11-1 Self-Controlled Oscillators

The amplifying properties of a three- (or more) element vacuum tube or a three-terminal transistor give them the ability to generate an alternating current of a frequency determined by auxiliary components associated with them. Such circuits are termed *oscillators*. To generate a-c power with an amplifier, a portion of the output power must be returned or fed back to the input in phase with the starting power (figure 1). The power delivered to the load will be the output power less the feedback power.

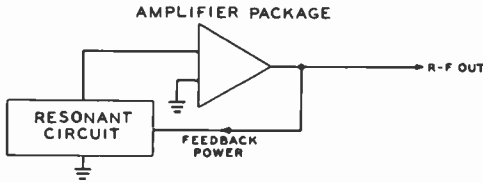

Figure 1

THREE TERMINAL OSCILLATOR

A portion of the output of a three-terminal amplifier is fed back to the input in proper phase and amplitude with the starting power which is generated initially by thermal noise. Power delivered to the load is output power less feedback power. Resonant circuit in input determines frequency of oscillation.

Initial Oscillation may be initially caused in a transistor or tube circuit by external triggering, or by self-excitation. In the latter case, at the moment the d-c power is applied, the energy level does not instantly reach maximum but, instead, gradually approaches it. Oscillations build up to a point limited by the normal operation of the amplifier, the feedback energy, and the nonlinear condition of the circuit. Practical oscillator circuits employ a variety of feedback paths, and some of the most useful ones are shown in figure 2. Either tubes or transistors may be used in these circuits.

The oscillator is commonly described in terms of the feedback circuit. The *Hartley* oscillator (figure 2A) employs a tapped inductor in the resonant circuit to develop the proper phase relationship for the feedback voltage, while the *Colpitts* oscillator derives the exciting voltage by means of a capacitive voltage divider. The *Clapp* circuit (figure 2C) employs a series-tuned tank circuit, shunted by a large capacitive voltage divider (C_1 - C_2). The *Vackar* oscillator (figure 2D) resembles the Clapp except that the feedback path is different. The tank coil is shunted by a large value of capacitance (C_1 - C_2) and the circuit is tuned by means of capacitor C_3 . The degree of feedback is controlled by the ratio C_1/C_2 . The *Seiler* oscillator (figure 2E) is a simplified version of the Vackar in which one side of the oscillatory circuit is grounded.

Vacuum-tube versions of the various oscil-

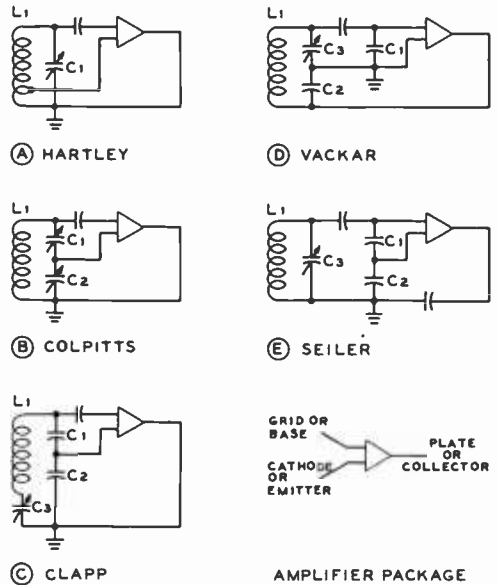

Figure 2

COMMON TYPES OF SELF-EXCITED OSCILLATORS

Circuits are named after inventor and are based on variations in method of coupling and introducing feedback into oscillator tank circuit. A—Inductive feed back. B—Capacitive feedback. C—Capacitive feedback plus series-tuned tank circuit. D—Capacitive feedback plus parallel-tuned tank circuit. E—Capacitive feedback with separate parallel-tuned tank circuit. Circuits may be used with either tubes or transistors by variations in feedback amplitude and applied potentials.

lator circuits are shown in figure 3. The basic *Hartley* oscillator is shown in figure 3A and the operation of this oscillator will serve as an index to the operation of all negative-grid oscillators; the only real difference between the various circuits is the manner in which the feedback energy for excitation is coupled from the plate to the grid circuit.

When plate voltage is applied to the Hartley oscillator shown at (A), the sudden flow of plate current accompanying the application of plate voltage will cause an electromagnetic field to be set up in the vicinity of the coil. The building-up of this field will cause a potential drop to appear from turn to turn along the coil. Due to the inductive coupling between the portion of the coil in which the plate current is flowing and the

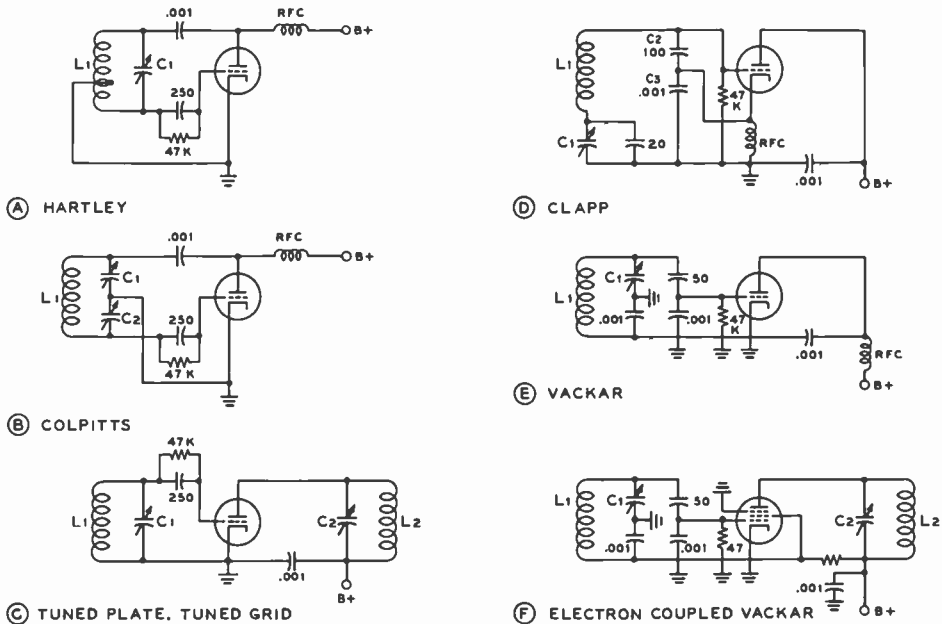

Figure 3

VACUUM-TUBE SELF-EXCITED OSCILLATORS

A—Shunt-fed Hartley. **B—Shunt-fed Colpitts.** **C—Series-fed oscillator with feedback accomplished through plate-to-grid interelectrode capacitance.** **D—Clapp oscillator employs series-resonant tuned circuit. Capacitor C₁ is of the order of 50 pf.** **E—Vackar circuit is variation of Clapp circuit having improved tuning range and more constant output.** **F—Electron-coupled oscillator using screen element of tube as the plate of the oscillator.**

grid portion, a potential will be induced in the grid portion.

Since the cathode tap is between the grid and plate ends of the coil, the induced grid voltage acts in such a manner as to increase further the plate current to the tube. This action will continue for a short period of time determined by the inductance and capacitance of the tuned circuit, until the *fly-wheel effect* of the tuned circuit causes this action to come to a maximum and then to reverse itself. The plate current then decreases (the magnetic field around the coil also decreasing) until a minimum is reached, when the action starts again in the original direction and at a greater amplitude than before. The amplitude of these oscillations, the frequency of which is determined by the coil-capacitor circuit, will increase in a very short period of time to a limit determined by the plate voltage of the oscillator tube.

The Colpitts Figure 3B shows a version of the *Colpitts* oscillator. It can be seen that this is essentially the same circuit as the Hartley except that the ratio of a pair of capacitances in series determines the effective cathode tap, instead of actually using a tap on the tank coil. Also, the net capacitance of these two capacitors comprises the tank capacitance of the tuned circuit. This oscillator circuit is somewhat less susceptible to parasitic (spurious) oscillations than the Hartley.

For best operation of the Hartley and Colpitts oscillators, the voltage from grid to cathode, determined by the tap on the coil or the setting of the two capacitors, normally should be from 1/3 to 1/5 that appearing between plate and cathode.

The T.P.T.G. The *tuned-plate tuned-grid* oscillator illustrated at (C) has

a tank circuit in both the plate and grid circuits. The feedback of energy from the plate to the grid circuits is accomplished by the plate-to-grid interelectrode capacitance within the tube. The necessary phase reversal in feedback voltage is provided by tuning the grid tank capacitor to the low side of the desired frequency and the plate capacitor to the high side. A broadly resonant coil may be substituted for the grid tank to form the T.N.T. (tuned-not tuned) oscillator.

Electron-Coupled Oscillators

In any of the oscillator circuits just described it is possible to take energy from the oscillator circuit by coupling an external load to the tank circuit. Since the tank circuit determines the frequency of oscillation of the tube, any variations in the conditions of the external circuit will be coupled back into the frequency-determining portion of the oscillator. These variations will result in frequency instability.

The frequency-determining portion of an oscillator may be coupled to the load circuit only by an electron stream, as illustrated in (F) of figure 3. When it is considered that the screen of the tube acts as the plate to the oscillator circuit, the plate merely acting as a coupler to the load, then the similarity between the cathode-grid-screen circuit of these oscillators and the cathode-grid-plate circuits of the corresponding prototype can be seen.

The *electron-coupled* oscillator has good stability with respect to load and voltage variation. Load variations have a relatively small effect on the frequency, since the only coupling between the oscillating circuit and the load is through the electron stream flowing through the other elements to the plate. The plate is electrostatically shielded from the oscillating portion by the bypassed screen.

The Clapp Oscillator The *Clapp* oscillator differs from the previous circuits in that it employs a series-resonant circuit while in all the more common oscillator circuits the frequency-controlling circuit is parallel resonant.

The Clapp oscillator operates in the following manner: at the resonant frequency of

the oscillator tuned circuit (L_1, C_1) the impedance of this circuit is at minimum (since it operates in series resonance) and maximum current flows through it. Note however, that C_2 and C_3 also are included within the current path for the series-resonant circuit, so that at the frequency of resonance an appreciable voltage drop appears across these capacitors. The voltage drop appearing across C_2 is applied to the grid of the oscillator tube as excitation, while the amplified output of the oscillator tube appears across C_3 as the driving power to keep the circuit in oscillation.

Capacitors C_2 and C_3 should be made as large in value as possible, while still permitting the circuit to oscillate over the full tuning range of C_1 . The larger these capacitors are made, the smaller will be the coupling between the oscillating circuit and the tube, and consequently the better will be oscillator stability with respect to tube variations. High- G_m tubes such as the 6AH6, 5763, and 6CB6 will permit the use of larger values of capacitance at C_2 and C_3 than will more conventional tubes such as the 6BA6, 6AQ5, and such types. In general it may be said that the reactance of capacitors C_2 and C_3 should be on the order of 40 to 120 ohms at the operating frequency of the oscillator—with the lower values of reactance going with high- G_m tubes and the higher values being necessary to permit oscillation with tubes having G_m in the range of 2000 micromhos.

It will be found that the Clapp oscillator will have a tendency to vary in power output over the frequency range of tuning capacitor C_1 . The output will be greatest where C_1 is at its largest setting, and will tend to fall off with C_1 at minimum capacitance. In fact, if capacitors C_2 and C_3 have too large a value the circuit will stop oscillating near the *minimum* capacitance setting of capacitor C_1 .

Hence it will be necessary to use a slightly *smaller* value of capacitance at C_2 and C_3 (to provide an increase in the capacitive reactance at this point), or else the frequency range of the oscillator must be restricted by paralleling a fixed capacitor across C_1 so that its effective capacitance at minimum setting will be increased to a value which will sustain oscillation.

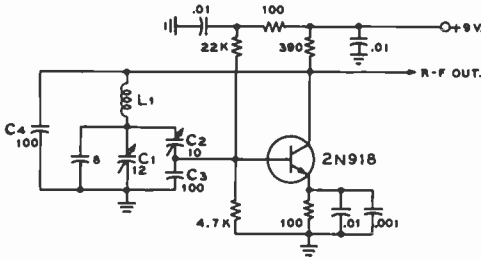

Figure 4

TRANSISTORIZED VACKAR OSCILLATOR

Thirty-MHz oscillator for vhf frequency control. Coil L₁ is 1.5 μH, wound on a ceramic form. Capacitor C₄ is adjusted for optimum drive level.

The Vackar Oscillator The Vackar oscillator is a variation of the basic Clapp circuit which has improved tuning range and relatively constant output combined with good stability with respect to a varying load. A practical Vackar circuit designed for 30 MHz is shown in figure 4. With the constants shown, the range is from 26.9 to 34.7 MHz, with an output amplitude change of less than -1.5 db relative to the lower frequency. Capacitor C₁ tunes the circuit while capacitor C₂ is adjusted for optimum drive level such that the transistor is not driven to cutoff or saturation. The output level, when properly adjusted, is about 4 volts peak-to-peak for a 9-volt supply. The emitter-bias resistor is bypassed for r-f and audio frequencies to eliminate a tendency for the circuit to oscillate at a parasitic frequency that is low in comparison to the working frequency. The value of capacitors C₃ and C₄ are approximately:

$$C \text{ (pf)} = \frac{3000}{f \text{ (MHz)}}$$

The frequency of oscillation is approximately:

$$f_{(osc)} = \frac{1}{2\pi \sqrt{L(C_1 + C_2)}}$$

The Seiler Oscillator The Seiler oscillator is another variation of the Clapp circuit, permitting one end of the tank

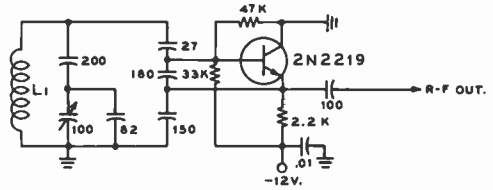

Figure 5

TRANSISTORIZED SEILER OSCILLATOR

Seiler oscillator is a variation of the Clapp circuit which permits one end of the tank coil to be at ground potential. Coil is 22 turns # 16e., 1/4" diam., close wound for range of 5.0-5.6 MHz.

coil to be at ground potential, and exhibiting slightly less loading of the tuned circuit than either the Vackar or the Clapp configuration. The large capacitors placed across the amplifying tube or transistor tend to swamp out any reactive changes in the active device and also limits the harmonic output, thereby enhancing frequency stability. A Seiler oscillator designed for SSB service is shown in figure 5.

Negative-Resistance Oscillators Negative - resistance oscillators often are used when unusually high frequency stability is desired, as in a frequency meter. The dynatron of a few years ago and the newer transitron are examples of oscillator circuits which make use of the negative-resistance characteristic between different elements in some multigrad tubes.

In the dynatron, the negative resistance is a consequence of secondary emission of electrons from the plate of a tetrode tube. By a proper proportioning of the electrode voltage, an increase in screen voltage will cause a decrease in screen current, since the increased screen voltage will cause the screen to attract a larger number of the secondary electrons emitted by the plate. Since the net screen current flowing from the screen supply will be decreased by an increase in screen voltage, it is said that the screen circuit presents a negative resistance.

If any type of tuned circuit, or even a resistance-capacitance circuit, is connected in series with the screen, the arrangement will oscillate—provided, of course, that the external circuit impedance is greater than the negative resistance. A negative-resistance

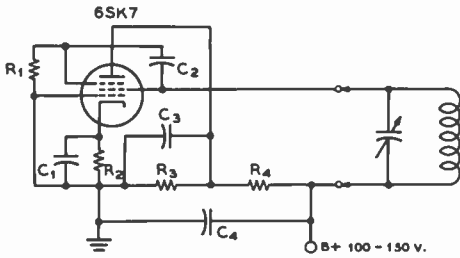

(A) TRANSITRON OSCILLATOR

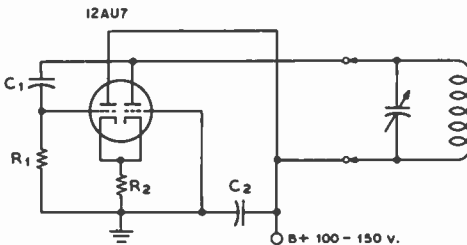

(B) CATHODE COUPLED OSCILLATOR

Figure 6

TWO-TERMINAL OSCILLATOR CIRCUITS

Both circuits may be used for an audio oscillator or for frequencies into the vhf range simply by placing a tank circuit tuned to the proper frequency where indicated on the drawing. Recommended values for the components are given below for both oscillators.

TRANSITRON OSCILLATOR

- C₁—0.01- μ fd mica for r.f. 10- μ fd elect. for a.f.
- C₂—0.00005- μ fd mica for r.f. 0.1- μ fd paper for a.f.
- C₃—0.003- μ fd mica for r.f. 0.5- μ fd paper for a.f.
- C₄—0.01- μ fd mica for r.f. 8- μ fd elect. for a.f.
- R₁—220K 1/2-watt carbon
- R₂—1800 ohms 1/2-watt carbon
- R₃—22K 2-watt carbon
- R₄—22K 2-watt carbon

CATHODE-COUPLED OSCILLATOR

- C₁—0.00005- μ fd mica for r.f. 0.1- μ fd paper for audio
- C₂—0.003- μ fd mica for r.f. 8- μ fd elect. for audio
- R₁—47K 1/2-watt carbon
- R₂—1K 1-watt carbon

effect similar to the dynatron is obtained in the *transitron* circuit, which uses a pentode with the suppressor coupled to the screen. The negative resistance in this case is obtained from a combination of secondary emission and interelectrode coupling, and is considerably more stable than that obtained from uncontrolled secondary emission alone in the dynatron. A representative transitron oscillator circuit is shown in figure 6A.

The chief distinction between a conventional *negative-grid* oscillator and a *negative-resistance* oscillator is that in the former the tank circuit must act as a phase inverter in order to permit the amplification of the tube to act as a negative resistance, while in the latter the tube acts as its own phase inverter (figure 6B). Thus a negative-resistance oscillator requires only an untapped coil and a single capacitor as the frequency-determining tank circuit, and is classed as a *two-terminal oscillator*. In fact, the time constant of an RC circuit may be used as the frequency-determining element and such an oscillator is rather widely used as a tunable audio-frequency oscillator.

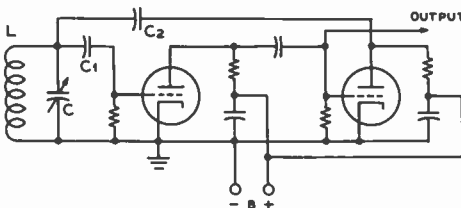

Figure 7

THE FRANKLIN OSCILLATOR CIRCUIT

A separate phase-inverter tube is used in this oscillator to feed a portion of the output back to the input in the proper phase to sustain oscillation. The values of C₁ and C₂ should be as small as will permit oscillations to be sustained over the desired frequency range.

The Franklin Oscillator The *Franklin* oscillator makes use of two cascaded tubes to obtain the negative-resistance effect (figure 7). The tubes may be either a pair of triodes, tetrodes, or pentodes; a dual triode; or a combination of a triode and a multigrid tube. The chief advantage of this oscillator circuit is that the frequency-determining tank only has two terminals, and one side of the circuit is grounded.

The second tube acts as a phase inverter to

give an effect similar to that obtained with the dynatron or transitron, except that the effective transconductance is much higher. If the tuned circuit is omitted or is replaced by a resistor, the circuit becomes a *relaxation* oscillator or a *multivibrator*.

Oscillator Stability The oscillator providing minimum coupling between the active device and the tuned circuit has proven to have the highest degree of stability. However, this inherently good stability is with respect to tube or transistor variations; instability of the tuned circuit with respect to vibration or temperature will of course have as much effect on the frequency of oscillation as with any other type of oscillator circuit. Solid mechanical construction of the components of the oscillating circuit, along with a small negative-coefficient compensating capacitor included as an element of the tuned circuit, usually will afford an adequate degree of oscillator stability.

VFO Transmitter Controls When used to control the frequency of a transmitter in which there are stringent limitations on frequency tolerance, several precautions are taken to ensure that a variable-frequency oscillator will stay on frequency. The oscillator is fed from a voltage-regulated power supply, uses a well-designed and temperature-compensated tank circuit, is of rugged mechanical construction to avoid the effects of shock and vibration, is pro-

tected against excessive changes in ambient room temperature, and is isolated from feedback or stray coupling from other portions of the transmitter by shielding, filtering of voltage supply leads, and incorporation of one or more buffer-amplifier stages. In a high-power transmitter a small amount of stray coupling from the final amplifier to the oscillator can produce appreciable degradation of the oscillator stability if both are on the same frequency. Therefore, the oscillator usually is operated on a subharmonic or image of the transmitter output frequency, with one or more frequency multipliers or mixers between the oscillator and final amplifier.

11-2 Quartz-Crystal Oscillators

Quartz is a naturally occurring crystal having a structure such that when plates are cut in certain definite relationships to the crystallographic axes, these plates will show the *piezoelectric effect*. That is, the plates will be deformed in the influence of an electric field, and, conversely, when such a plate is deformed in any way a potential difference will appear on its opposite sides.

A quartz-crystal plate has several mechanical resonances. Some of them are at very-high frequencies because of the stiffness of the material. Having mechanical resonance, like a tuning fork, the crystal will vibrate at a frequency depending on the dimensions, the method of electrical excitation, and crystallographic orientation. Because of the piezoelectric properties, it is possible to cut a quartz plate which, when provided with suitable electrodes, will have the characteristics of a resonant circuit having a very high LC ratio. The circuit Q of a crystal is many times higher than can be obtained with conventional inductors and capacitors of any size. The Q of crystals ranges from 10,000 to several million.

The equivalent electrical circuits of a quartz-crystal plate are shown in figure 8. The shunt capacitance of the electrodes and holder is represented by C_0 , and the capacitance between the electrodes with quartz as the dielectric is C_e . The series capacitance (C_1) represents the motional elasticity of

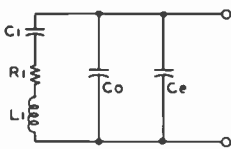

Figure 8

EQUIVALENT CIRCUIT OF A QUARTZ PLATE

The equivalent series-resonant circuit of the crystal itself is at the left, with shunt capacitance of electrodes and holder (C_0) and capacitance between electrodes with quartz as the dielectric (C_e) at right. The composite circuit may exhibit both series resonance and parallel resonance (antiresonance), the separation in frequency between the two modes being very small and determined largely by the ratio of series capacitance (C_1) to shunt capacitance.

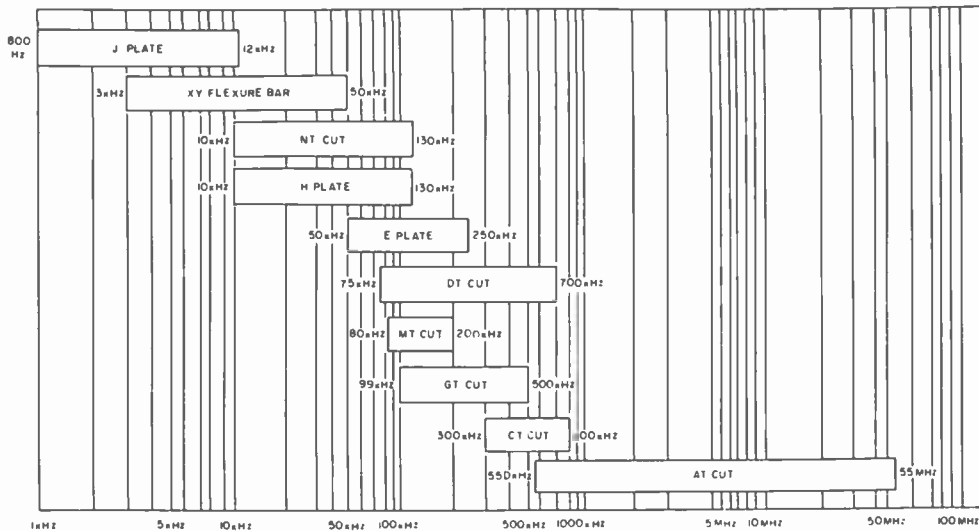

Figure 9
FREQUENCY RANGE OF CRYSTAL CUTS

the quartz, while the inductance (L_1) is a function of the mass. The series resistance (R_1) represents the sum of the crystal losses, including friction, acoustic loading, and power transmitted to the mounting structure.

Practical Quartz Crystals

While quartz, tourmaline, Rochelle salts, ADP, and EDT crystals all exhibit the piezoelectric effect, only quartz has a low temperature coefficient and exhibits chemical and mechanical stability. The greater part of the raw quartz used today for frequency control is man-made rather than natural and crystal blanks are produced in large quantities at low prices. The crystal blank is cut from a billet of quartz at a predetermined orientation with respect to the optical and electrical axes, the orientation determining the activity, temperature coefficient, thickness coefficient, and other characteristics of the crystal.

The crystal blank is rough-ground almost to frequency, the frequency increasing in inverse ratio to the oscillating dimensions (usually the thickness, but often the length). It is then finished to exact frequency by careful lapping, by etching, or by plating. Care is taken to stabilize the crystal so frequency and activity will not change with time.

Unplated crystals are mounted in pressure holders, in which an air gap exists between the crystal and electrodes. Only the corners of the crystal are clamped. At frequencies requiring a low ratio of length to thickness (usually below 2 MHz or so) a "free" air gap is required because even the corners of the crystal move.

Control of the orientation of the blank when cut from the quartz billet determines the characteristics of the crystal. The *turning point* (point of zero temperature coefficient) may be adjusted to room temperature, usually taken as 20° C. A graph of the normal frequency ranges of popular crystal cuts is shown in figure 9. For frequencies between 550 kHz and 55 MHz, the AT-cut crystal is now widely used. A large quantity of BT-cut crystals in the range of 6 MHz to 12 MHz exists as surplus stock from World War II. These crystals are mounted in the obsolete FT-243 style holder. The AT-cut, however, is now used because modern techniques allow it to be produced cheaply, and in quantity.

Crystal Holders

Crystals are normally purchased ready-mounted. Modern high-frequency crystals are mounted within metal holders, hermetically sealed with glass insulation and a metal-to-glass bond. Older crystal types make use of a phenolic holder

QUARTZ CRYSTAL HOLDERS

Holder Type	Pin Spacing	Pin Diam.	Size		
			H	W	T
HC-5/U	0.812	0.156	2.20	1.82	1.60
HC-6/U	0.486	0.050	0.78	0.76	0.35
HC-10/U	(1)	0.060	1.10	—	0.56D
HC-13/U	0.486	0.050	0.78	0.76	0.35
HC-17/U	0.486	0.093	0.78	0.76	0.35
HC-18/U	(2)	—	0.53	0.40	0.15
HC-25/U	0.192	0.040	1.53	0.76	0.35
FT-243	0.500	0.093	1.10	0.90	0.40

(1)—Barrel Mount
(2)—Wire Leads 0.018 Diam.

QUARTZ CRYSTAL TYPES

Mil. Type	Holder Used	Type	Resonance
CR-15B/U	HC-5/U	Fund.	Parallel
CR-16B/U	HC-5/U	Fund.	Series
CR-17/U	HC-10/U	Overtone	Series
CR-18A/U	HC-6/U	Fund.	Parallel
CR-19A/U	HC-6/U	Fund.	Series
CR-23/U	HC-6/U	Overtone	Series
CR-24/U	HC-10/U	Overtone	Series
CR-27/U	HC-6/U	Fund.	Parallel
CR-28A/U	HC-6/U	Fund.	Series
CR-32A/U	HC-6/U	Overtone	Series
CR-52A/U	HC-6/U	Overtone	Series
CR-53A/U	HC-6/U	Overtone	Series

Figure 10
CRYSTAL HOLDERS AND TYPES

sealed with a metal plate and a rubber gasket. A summary of crystal holders and crystal types is given in figure 10.

Precision crystals for calibrating equipment are vacuum-sealed in a glass envelope. Special vacuum-sealed crystals having a relatively constant temperature coefficient are used in high-stability frequency standards in place of the near-obsolete and expensive temperature-controlled "crystal oven."

Overtone-cut Crystals Just as a vibrating string can be made to vibrate on its overtone frequencies, a quartz crystal will exhibit mechanical resonance (and therefore electrical resonance) at overtones of its fundamental frequency. (The terms

overtone and *harmonic* should not be used interchangeably. The overtone is a mechanical phenomenon and its frequency differs from the harmonic by virtue of the mechanical loading of the crystal. The harmonic is an electrical phenomenon and is an exact multiple of the fundamental frequency.)

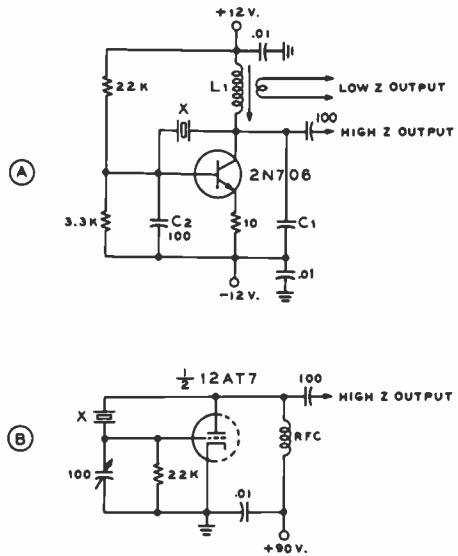

Figure 11

PIERCE CRYSTAL-OSCILLATOR CIRCUITS

A—Transistor oscillator. Capacitor C resonates coil L₁ to output frequency, which may be an overtone of crystal frequency. **B—**Base-to-ground capacitor (C₁) determines degree of feedback.

B—Vacuum-tube version of Pierce oscillator. Feedback is controlled by grid-to-ground capacitor. Output is at fundamental of crystal frequency.

By grinding the crystal especially for overtone operation, it is possible to enhance its operation as an overtone resonator. AT-cut crystals designed for optimum overtone operation on the 3rd, 5th, and even the 7th overtone are available. The 5th- and 7th-overtone types, especially the latter, require special holders and circuits for satisfactory operation, but the 3rd-overtone type needs little more consideration than a reg-

ular fundamental type. It is possible in some circuits to operate a crystal on the fundamental and 3rd overtone simultaneously and produce an audio beat between the third harmonic and the third overtone. Unless specifically desired, this operation is to be avoided in conventional circuits.

The overtone frequency for which the crystal is designed is the working frequency, which is not the fundamental, since the crystal actually oscillates on this working frequency when it is functioning in the proper manner. The Q of an overtone crystal, moreover, is much higher than that of a fundamental crystal of the same frequency. As a result, overtone crystals are less prone to frequency change brought about by changes of oscillator input capacitance. Many frequency-standard crystals in the h-f range, therefore, are overtone types.

Crystal Drive Level Crystal dissipation is a function of the drive level. Excessive crystal current may lead to frequency drift and eventual fracture of the blank. The crystal oscillator should be run at as low a power level as possible to reduce crystal heating. Drive levels of 5 milliwatts or less are recommended for fundamental AT blanks in HC-6/U style holders, and a level of 1 milliwatt maximum is recommended for overtone crystals or fundamental crystals above 10 MHz in HC-6/U holders. The older FT-243 style crystal is capable of somewhat greater drive levels by virtue of the larger blank size.

Series and Parallel Resonance The shunt capacitance of the electrodes and associated wiring is considerably greater than the capacitive component of an equivalent series LC circuit, and unless the shunt capacitance is balanced out, the crystal will exhibit both series- and parallel-resonance frequencies, the latter being somewhat higher than the former. The series-resonant condition is employed in filter circuits and in oscillator circuits wherein the crystal is used in such a manner that the phase shift of the feedback voltage is at the series-resonant frequency.

The only difference between crystals designed for series-resonance and those for

parallel-resonance operation is the oscillator input reactance (capacitance) for which they are calibrated. A crystal calibrated for parallel resonance will operate at its calibrated frequency in a series-resonant circuit with the addition of an appropriate value of series capacitance. Thus, a crystal cannot be specified in frequency without stating the reactance with which it is to be calibrated. The older FT-243 fundamental crystals were usually calibrated with a parallel capacitance of 35 pf, while many of the new hermetic sealed crystals are calibrated with a capacitance of 32 pf.

11-3 Crystal Oscillator Circuits

Crystals may replace the conventional inductance in a self-excited oscillator, the crystal oscillating at its series- or parallel-resonant frequency. The phase shift through the crystal is approximately zero, thus providing output-to-input feedback of the proper polarity. A simple crystal oscillator is shown in figure 11A. This is a *Pierce* circuit, wherein the crystal replaces the resonant circuit in a Colpitts oscillator and operates at its parallel-resonant frequency. The transistor is a low-impedance device, requiring that capacitors C_1 and C_2 be quite large. The circuit is suitable for low- or medium-impedance crystals on the fundamental or overtone frequency. The combination of L_1 and C_1 must resonate slightly *below* the frequency of the desired mode.

Shown in figure 11B is a tube version of the *Pierce* oscillator. The variable capacitor controls the degree of feedback and should be adjusted for reliable operation at the minimum possible capacitance setting.

Other oscillator circuits are suggested in figure 12.

Tuned-Plate Crystal Oscillator The *Miller*, or tuned-plate crystal oscillator is shown in figure 13A. The plate tank is tuned on the low capacitance side of resonance and oscillation occurs near the parallel-resonant frequency of the crystal.

The diagram shown in figure 13A is the

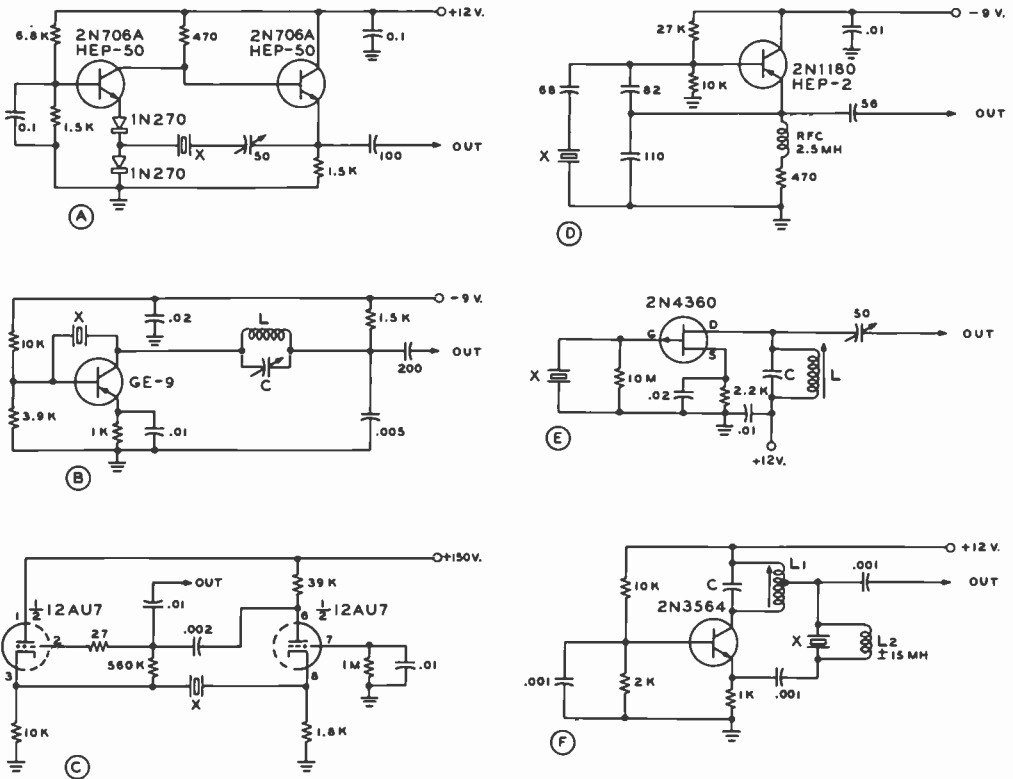

Figure 12

HIGH-FREQUENCY CRYSTAL-OSCILLATOR CIRCUITS

A—Transistorized Butler oscillator with amplitude-limiting diodes. The crystal is adjusted to frequency by series capacitor. Circuit is usable over range of 1 to 25 MHz. **B**—Transistorized Pierce oscillator with resonant circuit tuned to overtone frequency of the crystal. This circuit is suitable for overtone crystals in the range of 20 to 54 MHz. **C**—Vacuum-tube version of Butler oscillator with second triode section serving as a phase inverter. Circuit is designed for low-frequency operation (80 to 1000 kHz). **D**—General purpose h-f crystal oscillator for 2- to 30-MHz range. **E**—FET crystal oscillator for h-f range. Tuned circuit may be adjusted to overtone frequency of crystal. **F**—Overtone oscillator. Coil L₁ resonates to crystal frequency with capacitance of crystal holder.

basic circuit. The most popular version of the tuned-plate oscillator employs a pentode or beam tetrode with cathode bias to prevent excessive plate dissipation when the circuit is not oscillating. The cathode resistor is optional. Its omission will reduce both crystal current and oscillator efficiency, resulting in somewhat more output for a given crystal current. The tube usually is an audio or video beam pentode or tetrode, the plate-grid capacitance of such tubes being sufficient to ensure stable oscillation but not so high as to offer excessive feedback with

resulting high crystal current. The 6CL6 makes an excellent all-around tube for this type circuit.

Pentode Harmonic Crystal Oscillator Circuits

The usual type of crystal-controlled h-f transmitter operates, at least part of the time, on a frequency which is an approximate multiple of the operating frequency of the controlling crystal. Hence, oscillator circuits which are capable of providing output on the crystal

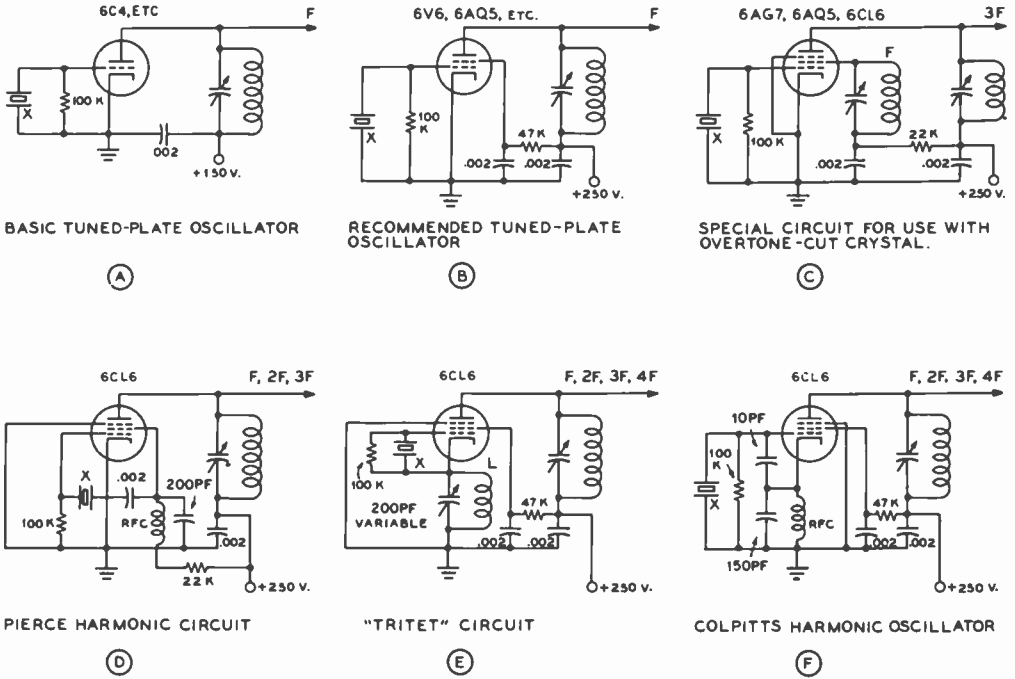

Figure 13

COMMONLY USED CRYSTAL OSCILLATOR CIRCUITS

Shown at A is the basic tuned-plate crystal oscillator with a triode oscillator tube. The plate tank must be tuned on the low-capacitance side of resonance to sustain oscillation. B shows the tuned-plate oscillator as it is normally used, with an a-f power pentode to permit high output with relatively low crystal current. Schematics C, D, E, and F illustrate crystal oscillator circuits which can deliver moderate output energy on harmonics of the oscillating frequency of the crystal. C shows a special circuit which will permit use of an overtone-cut crystal to obtain output energy well into the vhf range. D is valuable when extremely low crystal current is a requirement, but delivers relatively low output. E is commonly used, but is subject to crystal damage if the cathode circuit is mistuned. F is recommended as the most generally satisfactory from the standpoints of: low crystal current regardless of misadjustment, good output on harmonic frequencies, one side of crystal is grounded, will oscillate with crystals from 1.5 to 10 MHz without adjustment, output tank may be tuned to the crystal frequency for fundamental output without stopping oscillation or changing frequency.

frequency if desired, but which also can deliver output energy on harmonics of the crystal frequency have come into wide use. Four such circuits which have found wide application are illustrated in figures 13C through 13F.

The circuit shown in figure 13C is recommended for use with overtone-cut crystals when output is desired on a multiple of the oscillating frequency of the crystal. As an example, a 25-MHz overtone-cut crystal may be used in this circuit to obtain output on 50-MHz or a 48-MHz overtone-cut crystal may be used to obtain output on the 144-MHz amateur band. The circuit is not

recommended for use with the normal type of fundamental-frequency crystal since more output with fewer variable elements can be obtained with the circuits of 13D and 13F.

The *Pierce harmonic* circuit shown in figure 13D is satisfactory for many applications which require very low crystal current, but has the disadvantage that both sides of the crystal are above ground potential. The *Tritet* circuit of figure 13E is widely used and can give excellent output with low crystal current. However, the circuit has the disadvantages of requiring a cathode coil, of requiring careful setting of the variable cathode capacitor to avoid damaging the crystal

when changing frequency ranges, and of having both sides of the crystal above ground potential.

The *Colpitts harmonic oscillator* of figure 13F is recommended as being the most generally satisfactory harmonic crystal oscillator circuit since it has the following advantages: (1) the circuit will oscillate with crystals over a very wide frequency range with no change other than plugging in or switching in the desired crystal; (2) crystal current is extremely low; (3) one side of the crystal is grounded, which facilitates crystal-switching circuits; (4) the circuit will operate straight through without frequency pulling, or it may be operated with output on the second, third, or fourth harmonic of the crystal frequency.

Crystal Oscillator Tuning The tunable circuits of all oscillators illustrated should be tuned for maximum output as indicated by maximum excitation to the following stage, except that the oscillator tank of tuned-plate oscillators (figure 13A and figure 13B) should be backed off slightly toward the low capacitance side from maximum output, as the oscillator then is in a more stable condition and sure to start immediately when power is applied. This is especially important when the oscillator is keyed, as for break-in c-w operation.

Crystal Switching It is desirable to keep stray shunt capacitances in the crystal circuit as low as possible, regardless of the oscillator circuit. If a selector switch is used, this means that both switch and crystal sockets must be placed close to the oscillator-tube socket. This is especially true of overtone-cut crystals operating on a comparatively high frequency. In fact, on the highest frequency crystals it is preferable to use a turret arrangement for switching, since the stray capacitances can be kept lower.

A shorting switch should be used because an unused crystal, lower in frequency than the one in use can cause severe "suck out" or loss of oscillation through the capacity between the switch leads.

A Versatile 6CL6 Crystal Oscillator The 6CL6 tube may be used in a modified Tri-tet crystal oscillator, capable of delivering sufficient power on all bands from 160 meters through 10 meters to fully drive a pentode tube, such as the 807, 2E26, or 6146. Such an oscillator is extremely useful for portable or mobile work, since it combines all essential exciter functions in one tube. The circuit of this oscillator is shown in figure 14. For 160-, 80-, and 40-meter operation the 6CL6 functions as a tuned-plate oscillator. Fundamental-frequency crystals are used on these three bands. For 20-, 15-, and 10-meter operation the 6CL6 functions as a Tri-tet oscillator with a fixed-tuned cathode circuit. The impedance of this cathode circuit does not affect operation of the 6CL6 on the lower frequency bands so it is left in the circuit at all times. A 7-MHz crystal is used for fundamental output on 40 meters and for harmonic output on 20, 15, and 10 meters. Crystal current is extremely low regardless of the output frequency of the oscillator. The plate circuit of the 6CL6 is capable of tuning a frequency range of 2:1, requiring only two output coils: one for 80- 40-meter operation, and one for 20-, 15-, and 10-meter operation. In some cases it may be necessary to add 5 picofarads of external feedback capacity between the plate and control grid of the 6CL6 tube to sustain oscillation with sluggish 160-meter crystals.

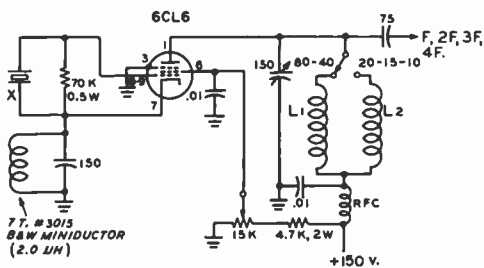

NOTES

1. L1 = 15 uH (2 1/2" OF B&W # 3015)
2. L2 = 1.6 uH (1" OF B&W # 3003)
3. FOR 160 METER OPERATION, ADD 5PF CAPACITOR BETWEEN PINS 18 & 9 OF 5763 PLATE COIL-55UM, (2 1/2" OF B&W # 3016)
4. X = 7 MHz CRYSTAL FOR HARMONIC OPERATION

Figure 14

ALL-BAND CRYSTAL OSCILLATOR CAPABLE OF DRIVING BEAM-TETRODE TUBE. 6CL6 OR 5763 MAY BE USED

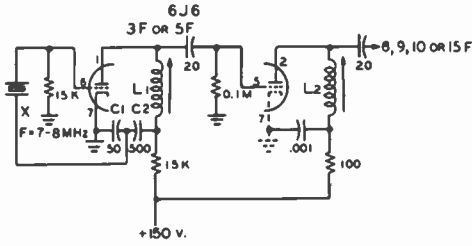

(A) JONES HARMONIC OSCILLATOR

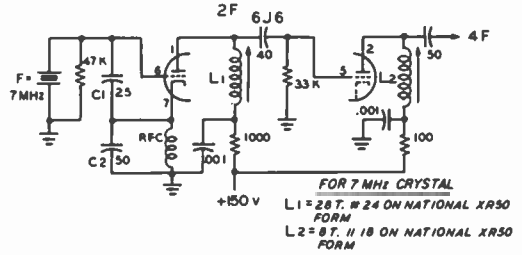

(B) COLPITTS HARMONIC OSCILLATOR

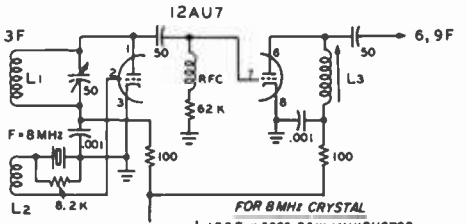

(C) REGENERATIVE HARMONIC OSCILLATOR

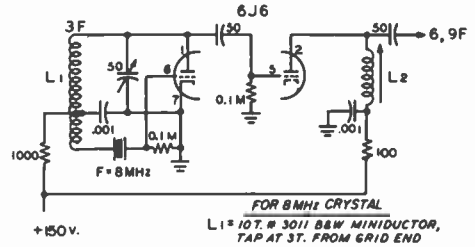

(D) REGENERATIVE HARMONIC OSCILLATOR

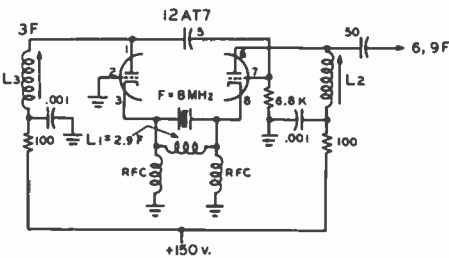

(E) CATHODE FOLLOWER OVERTONE OSCILLATOR

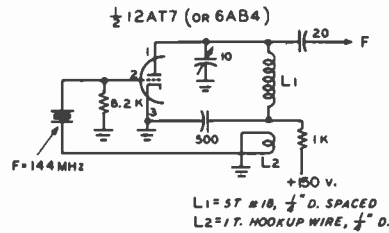

(F) V H F OVERTONE OSCILLATOR

Figure 15

VARIOUS TYPES OF OVERTONE OSCILLATORS USING MINIATURE DOUBLE-TRIODE VACUUM TUBES

Triode Overtone Oscillators The recent development of reliable overtone crystals capable of operation on the third, fifth, and seventh (or higher) overtones has made possible vhf output from a low-frequency crystal by the use of a double triode regenerative oscillator circuit. Some of the twin triode tubes such as the 12AU7, 12AV7, and 6J6 are especially satisfactory when used in this type of circuit. Crystals that are ground for overtone service may be made to oscillate on odd-overtone

frequencies other than the one marked on the crystal holder. A 24-MHz overtone crystal, for example, is a specially ground 8-MHz crystal operating on its third overtone. In the proper circuit it may be made to oscillate on 40 MHz (fifth overtone), 56 MHz (seventh overtone), or 72 MHz (ninth overtone). Even the ordinary 8-MHz crystals not designed for overtone operation may be made to oscillate readily on 24 MHz (third overtone) in these circuits.

A variety of overtone oscillator circuits is

shown in figure 15. The circuit of figure 15A is a variety of the basic Pierce oscillator. The first section of the 6J6 dual triode comprises a regenerative oscillator, with output on either the third or fifth overtone of the crystal frequency. The regenerative loop of this oscillator consists of a capacitance bridge made up of C_1 and C_2 with the ratio C_2/C_1 determining the amount of regenerative feedback in the circuit. With an 8-MHz crystal, output from the first section of the 6J6 tube may be obtained on either 24 or 40 MHz, depending on the resonant frequency of the plate circuit inductor (L_1). The second half of the 6J6 acts as a frequency multiplier, its plate circuit (L_2) tuned to the sixth- or ninth-harmonic frequency when L_1 is tuned to the third overtone, or to the tenth-harmonic frequency when L_1 is tuned to the fifth overtone.

Figure 15B illustrates a Colpitts overtone oscillator employing a 6J6 tube. This is an outgrowth of the Colpitts harmonic oscillator of figure 13F. The regenerative loop in this case consists of C_1 , C_2 , and RFC between the grid, cathode, and ground of the first section of the 6J6. The plate circuit of the first section is tuned to the second, harmonic of the crystal, and the second section of the 6J6 doubles to the fourth harmonic of the crystal. This circuit is useful in obtaining 28-MHz output from a 7-MHz crystal and is highly popular in mobile work.

The circuit of figure 15C shows a typical regenerative overtone oscillator employing a 12AU7 double-triode tube. Feedback is controlled by the number of turns in L_2 , and the coupling between L_2 and L_1 . Only enough feedback should be employed to maintain proper oscillation of the crystal. Excessive feedback will cause the first section of the 12AU7 to oscillate as a self-excited T.N.T. oscillator, independent of the crystal. A variety of this circuit is shown in figure 15D, wherein a tapped coil, (L_1) is used in place of the two separate coils. Operation of the circuit is the same in either case, regeneration now being controlled by the placement of the tap on L_1 .

A cathode-follower overtone oscillator is shown in figure 15E. The cathode coil (L_1) is chosen so as to resonate with the crystal and tube capacities just below the third-overtone frequency of the crystal. For ex-

ample, with an 8-MHz crystal, L_3 is tuned to 24 MHz, L_1 resonates with the circuit capacities to 23.5 MHz, and the harmonic tank circuit of the second section of the 12AT7 is tuned either to 48 MHz or 72 MHz. If a 24-MHz overtone crystal is used in this circuit, L_3 may be tuned to 72 MHz, L_1 resonates with the circuit capacities to 70 MHz, and the harmonic tank circuit (L_2) is tuned to 144 MHz. If there is any tendency toward self-oscillation in the circuit, it may be eliminated by a small amount of inductive coupling and between L_2 and L_3 . Placing these coils near each other, with the winding of L_2 correctly polarized with respect to L_3 will prevent self-oscillation of the circuit.

The use of a 144-MHz overtone crystal is illustrated in figure 15F. A 6AB4 or one-half of a 12AT7 tube may be used, with output directly in the 2-meter amateur band. A slight amount of regeneration is provided by the one turn link, (L_2) which is loosely coupled to the 144-MHz tuned tank circuit (L_1) in the plate circuit of the oscillator tube. If a 12AT7 tube and a 110-MHz crystal are employed, direct output in the 220-MHz amateur band may be obtained from the second half of the 12AT7.

Inductive Loading of Crystals A relatively wide frequency range of operation of a crystal oscillator may be achieved by operating the crystal below its resonant frequency and loading it

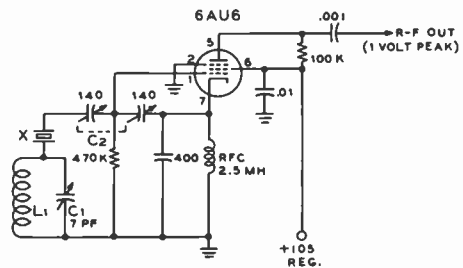

Figure 16

VARIABLE-FREQUENCY CRYSTAL OSCILLATOR

Inductive loading of crystal permits frequency change as great as two percent of nominal crystal frequency. Range covers from slightly above to nearly two percent below resonant frequency. Coil L_1 is 30 μ H. Maximum range is adjusted by capacitor C_2 . Circuit is tuned by capacitor C_1 .

with an inductance. Frequency stability is reduced by a factor of about 10, but bandwidth operation up to 2 percent of the crystal frequency may be achieved (figure 16). A series combination of a fixed inductor and a variable capacitor will permit oscillation from slightly above to about 2 percent below the parallel-resonant frequency of the crystal.

11-4 Radio-Frequency Amplifiers

The output of the oscillator stage in a transmitter must be held down to a comparatively low level to maintain stability and to retain a factor of safety from fracture of the crystal when one is used. The low-level signal is brought up to the desired power level by means of radio-frequency amplifiers. The three classes of r-f amplifiers that find widest application in modern radio transmitters are the class AB₁, class-B, and class-C types.

The angle of plate-current conduction determines the class of operation. Class B is a 180-degree conduction angle and class C is less than 180 degrees. Class AB is the region between 180 degrees and 360 degrees of conduction. The subscript "1" indicates that no grid current flows, and the subscript "2" means that grid current is present. The class of operation has nothing to do with whether the amplifier is grid driven or cathode driven (grounded grid). A cathode-driven amplifier, for example, can be operated in any desired class, within limitations imposed by the tube.

The Classes of Amplifiers The class-AB amplifier can be operated with very low intermodulation distortion in linear amplifier service. Typical plate efficiency is about 60 percent, and stage gain is about 20 to 25 decibels. The class-B amplifier will generate more intermodulation distortion than the class-AB circuit but the distortion level is acceptable in many applications. Typical plate efficiency is about 66 percent and power gains of 15 to 20 decibels are readily achieved. The class-C amplifier is used where large amounts of r-f power are to be amplified with high

efficiency. Class-C amplifiers operate with considerably more than cutoff bias, much like a limiter; therefore, this configuration cannot amplify a modulated signal without serious distortion. Class-C amplifiers are used for high-level amplitude modulation wherein the plate voltage (or plate and screen voltages for tetrodes) is modulated at an audio rate. The output power of a class-C amplifier, adjusted for plate modulation, varies with the square of the plate voltage. That is the same condition that would take place if a resistor equal to the voltage on the amplifier, divided by the plate current, were substituted for the amplifier. Therefore, the stage presents a resistive load to the plate modulator. Typical plate efficiency is 70 percent and stage gain is 8 to 10 decibels.

Grid-Modulated Class C If the grid current to a class-C amplifier is reduced to a low value, and the plate loading is increased to the point where the plate dissipation approaches the rated value, the amplifier may be grid modulated for radiotelephony. If the plate voltage is high, efficiency up to 40 percent is possible.

Grid Excitation Adequate grid excitation must be available for class-B or class-C service. The excitation for a plate-modulated class-C stage must be sufficient to produce a normal value of d-c grid current with rated bias voltage. The bias voltage preferably should be obtained from a combination of grid-resistor and fixed grid-bias supply.

Cutoff bias can be calculated by dividing the amplification factor of the tube into the d-c plate voltage. This is the value normally used for class-B amplifiers (fixed bias, no grid resistor). Class-C amplifiers use from 1.5 to 5 times this value, depending on the available grid drive, or excitation, and the desired plate efficiency. Less grid excitation is needed for c-w operation, and the values of fixed bias (if greater than cutoff) may be reduced, or the value of the grid-bias resistor can be lowered until normal rated d-c grid current flows.

The values of grid excitation listed for each type of tube may be reduced by as much as 50 percent if only moderate power output and plate efficiency are desired. When

consulting the tube tables, it is well to remember that the power lost in the tuned circuits must be taken into consideration when calculating the available grid drive. At very-high frequencies, the r-f circuit losses may even exceed the power required for actual grid excitation.

Excessive grid current damages tubes by overheating the grid structure; beyond a certain point of grid drive, no increase in power output can be obtained for a given plate voltage.

11-5 Neutralization of R-F Amplifiers

The plate-to-grid feedback capacitance of triodes makes it necessary that they be neutralized for operation as r-f amplifiers at frequencies above about 500 kHz. Those screen-grid tubes, pentodes, and beam tetrodes which have a plate-to-grid capacitance of 0.1 pf or less may be operated as an amplifier without neutralization in a well-designed amplifier up to 30 MHz provided the stage gain is less than the over-all feedback gain from output to input circuit.

Neutralizing Circuits The object of *neutralization* is to cancel or neutralize the capacitive feedback of energy from plate to grid. There are two general

methods by which this energy feedback may be eliminated: the first, and the most common method, is through the use of a capacitance bridge, and the second method is through the use of a parallel reactance of equal and opposite polarity to the grid-to-plate capacitance, to nullify the effect of this capacitance.

Examples of the first method are shown in figure 17. Figure 17A shows a capacitance-neutralized stage employing a balanced tank circuit. Phase reversal in the tank circuit is obtained by grounding the center of the tank coil to radio-frequency energy by capacitor C_1 . Points A and B are 180 degrees out of phase with each other, and the correct amount of out-of-phase energy is coupled through the neutralizing capacitor (NC) to the grid circuit of the tube. The equivalent bridge circuit of this is shown in figure 18A. It is seen that the bridge is not in balance, since the plate-filament capacitance of the tube forms one leg of the bridge, and there is no corresponding capacitance from the neutralizing capacitor (point B) to ground to obtain a complete balance. In addition, it is mechanically difficult to obtain a perfect electrical balance in the tank coil, and the potential between point A and ground and point B and ground, in most cases, is unequal. This circuit, therefore, holds neutralization over a very small operating range and unless tubes of low inter-

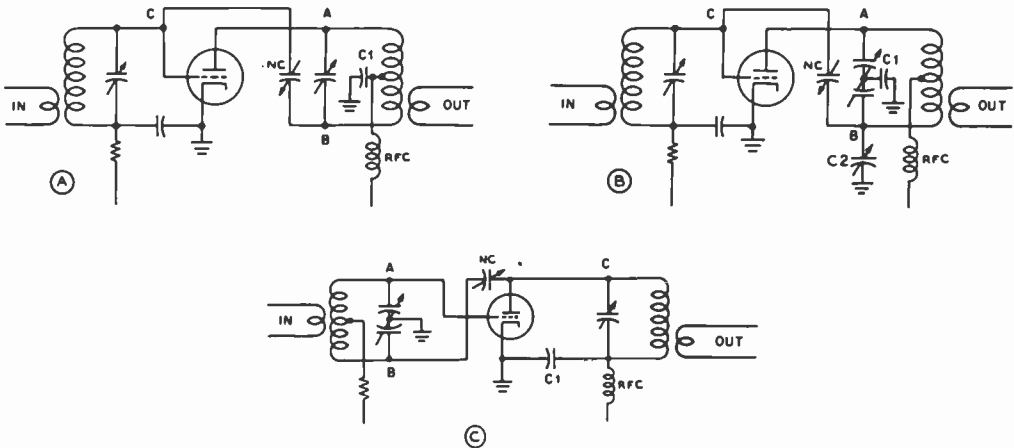

Figure 17

COMMON NEUTRALIZING CIRCUITS FOR SINGLE-ENDED AMPLIFIERS

electrode capacitance are used the inherent unbalance of the circuit will permit only approximate neutralization.

Split-Stator Plate Neutralization Figure 17B shows the neutralization circuit which is widely used in single-ended r-f stages. The use of a split-stator plate capacitor makes the electrical balance of the circuit substantially independent of the mutual coupling within the coil and also makes the balance independent of the place where the coil is tapped. With conventional tubes this circuit will allow one neutralization adjustment to be made on, for example, 28 MHz, and this adjustment usually will hold sufficiently close for operation on all lower-frequency bands.

Capacitor C_2 is used to balance out the plate-filament capacity of the tube to allow a perfect neutralizing balance at all frequencies. The equivalent bridge circuit is shown in figure 18B. If the plate-filament capacitance of the tube is extremely low (100TH triode, for example), capacitor C_2 may be omitted, or may merely consist of the residual capacity of NC to ground.

Grid Neutralization A split grid-tank circuit may also be used for neutralization of a triode tube as shown in figure 17C. Out of phase voltage is developed across a balanced grid circuit, and coupled through NC to the single-ended plate circuit of the tube. The equivalent bridge circuit is shown in figure 18C. This circuit is in balance until the stage is in operation when the loading effect of the tube upon one-half of the grid circuit throws the bridge circuit out of balance. The amount of unbalance depends on the grid-plate capacitance of the tube, and the amount of mutual inductance between the two halves of the grid coil. If an r-f voltmeter is placed between point A and ground, and a second voltmeter placed between point B and ground, the loading effect of the tube will be noticeable. When the tube is supplied excitation with no plate voltage, NC may be adjusted until the circuit is in balance. When plate voltage is applied to the stage, the voltage from point A to ground will decrease, and the voltage from point B to ground will increase, both in direct proportion to the amount of circuit unbalance.

The use of this circuit is not recommended above 7 MHz, and it should be used below that frequency only with low internal capacitance tubes.

Push-Pull Neutralization Two tubes of the same type can be connected for *push-pull* operation so as to obtain twice as much output as that of a single tube. A push-pull amplifier, such as that shown in figure 19 also has an advantage in that the circuit can more easily be balanced than a single-tube r-f amplifier. The various interelectrode capacitances and the neutralizing capacitors are connected in such a manner that the reactances on one side of the tuned circuits are exactly equal to those on the opposite side. For this reason, push-pull r-f amplifiers can be more easily neu-

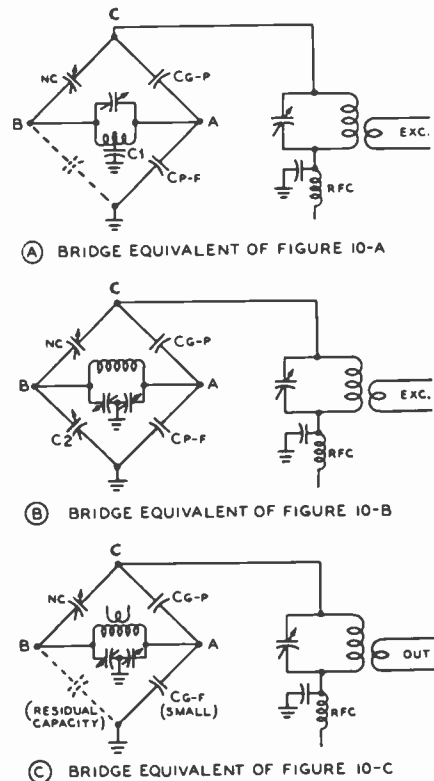

Figure 18

EQUIVALENT NEUTRALIZING CIRCUITS

tralized in vhf transmitters; also, they usually remain in perfect neutralization when tuning the amplifier to different bands.

The circuit shown in figure 19 is perhaps the most commonly used arrangement for a push-pull r-f amplifier stage. The rotor of the grid capacitor is grounded, and the rotor of the plate tank capacitor is bypassed to ground.

Shunt or Coil Neutralization The feedback of energy from grid to plate in an unneutralized r-f amplifier is a result of the grid-to-plate capacitance of the amplifier tube. A neutralization circuit is merely an electrical arrangement for nullifying the effect of this capacitance. All the previous neutralization circuits have made use of a bridge circuit for balancing out the grid-to-plate energy feedback by feeding back an equal amount of energy of opposite phase.

Another method of eliminating the feedback effect of this capacitance, and hence of neutralizing the amplifier stage, is shown in figure 20. The grid-to-plate capacitance in the triode amplifier tube acts as a capacitive reactance, coupling energy back from the plate to the grid circuit. If this capacitance is paralleled with an inductance having the same value of reactance of opposite sign, the reactance of one will cancel the reactance of the other and a high-impedance tuned circuit from grid to plate will result.

This neutralization circuit can be used on ultra high frequencies where other neutralization circuits are unsatisfactory. This is true because the lead length in the neutralization circuit is practically negligible. The

circuit can also be used with push-pull r-f amplifiers. In this case, each tube will have its own neutralizing inductor connected from grid to plate.

The main advantage of this arrangement is that it allows the use of single-ended tank circuits with a single-ended amplifier.

The chief disadvantage of the shunt neutralized arrangement is that the stage must be neutralized each time the stage is returned to a new frequency sufficiently removed that the grid and plate tank circuits must be returned to resonance. However, by the use of plug-in coils it is possible to change to a different band of operation by changing the neutralizing coil at the same time that the grid and plate coils are changed.

The 0.0001- μ fd capacitor in series with the neutralizing coil is merely a blocking capacitor to isolate the plate voltage from the grid circuit. The coil (L) will have to have a very large number of turns for the band of operation in order to be resonant with the comparatively small grid-to-plate capacitance.

Neutralization of Cathode-Driven Amplifiers Stable operation of the cathode-driven (grounded-grid) amplifier often requires neutralization, par-

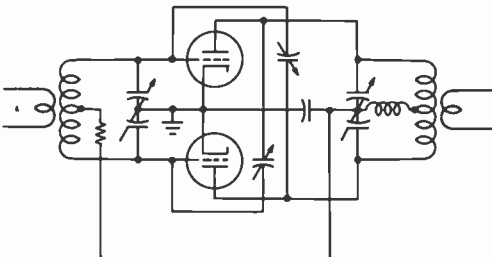

Figure 19

STANDARD CROSS-NEUTRALIZED PUSH-PULL TRIODE AMPLIFIER

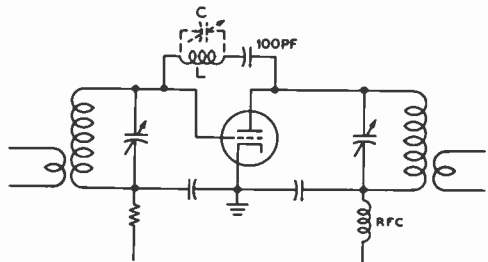

Figure 20

COIL-NEUTRALIZED AMPLIFIER

This neutralization circuit is very effective with triode tubes on any frequency, but is particularly effective in the vhf range. Coil L is adjusted so that it resonates at the operating frequency with the grid-to-plate capacitance of the tube. Capacitor C may be a very small unit of the low-capacitance neutralizing type and is used to trim the circuit to resonance at the operating frequency. If some means of varying the inductance of the coil a small amount is available, the trimmer capacitor is not needed.

ticularly above 25 MHz or so. Complete circuit stability requires neutralization of two feedback paths, as shown in figure 21.

The first path involves the cathode-to-plate capacitance and proper neutralization may be accomplished by a shunt inductance or by a balanced-bridge technique. The bridge technique is less critical of adjustment than the shunt-inductance circuit, and a reasonable bridge balance over a wide frequency range may be achieved with a single setting of the neutralizing capacitance.

The second feedback path includes the grid-to-plate capacitance, the cathode-to-grid capacitance and the series inductance of the grid-to-ground path (figure 22). If this path is not neutralized, a voltage appears on the grid of the tube which either increases or decreases the driving voltage, depending on the values of grid inductance and internal capacitances of the tube. A certain frequency exists at which these two feedback paths nullify each other and this self-neutralizing frequency may be moved about by adding either positive or negative reactance in the grid circuit, as shown in the illustration. If the operating frequency is above the self-neutralizing frequency a series capacitance is used to reduce the grid inductance. If the operating frequency is below the self-neutralizing frequency, the series grid inductance should be increased. For most tubes of the amateur power class, the self-neutralizing frequency lies between 50 and 150 MHz.

11-6 Neutralizing Procedures

Voltage feedback from output to input through the distributed constants of the vacuum tube has a deleterious effect on amplifier performance. The magnitude, phase and rate of change with respect to frequency of this feedback voltage determine the stability of the amplifier. Control of feedback is termed *neutralization*. The purpose of neutralization of an amplifier is to make the input and output circuits independent of each other with respect to voltage feedback. *Proper neutralization may be defined as the state in which, when output and input tank circuits are resonant,*

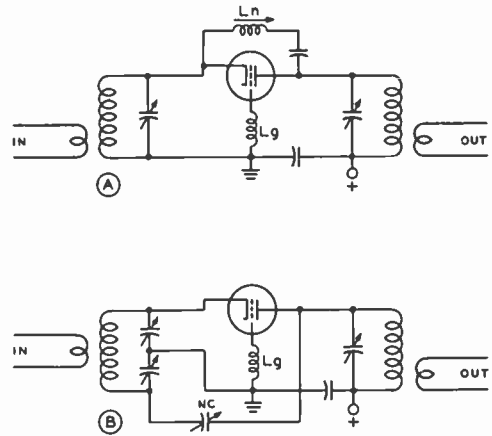

Figure 21

NEUTRALIZATION OF CATHODE DRIVEN AMPLIFIER

A—Cathode-to-plate feedback path may be neutralized by making it part of a parallel-tuned circuit by addition of neutralizing coil L_n . Series capacitor removes plate voltage from neutralizing coil. Adjustments tend to be frequency sensitive.

B—Cathode-to-plate feedback path is neutralized by introducing out-of-phase voltage from drive circuit into plate circuit by means of capacitor NC . Inductor L represents grid-lead inductance of vacuum tube, whose effects are not cancelled by either neutralizing circuit.

maximum drive voltage, minimum plate current, and maximum power output occur simultaneously.

The state of correct neutralization, therefore, may be judged by observing these operating parameters or by observing the degree of feedback present in the amplifier. The amplifier may be neutralized in the active or passive state provided proper instrumentation is used.

Passive Neutralization An amplifier may be neutralized in the passive state with the aid of a signal generator, an r-f voltmeter, and a grid-dip oscillator. The input and output circuits of the amplifier are resonated to the operating frequency and a small signal from the generator is applied to the input circuit of the amplifier. An r-f voltmeter (or well-shielded receiver) is connected to the output circuit of the amplifier. Neutralizing adjustments are now made to reduce to a minimum the feed-

through voltage reaching the receiver from the signal generator. Adjustments may be made with no filament or plate voltage applied to the amplifier. Once a null adjustment has been achieved, the amplifier may be activated and the neutralization adjustment touched up at full power level.

Passive neutralization is a highly recommended technique since no voltages are applied to the equipment, and adjustments and circuit modifications may be made without danger to the operator of accidental shock.

Active Neutralization An amplifier may be neutralized by the application of excitation with plate and screen voltage removed. A neutralizing indicator is coupled to the plate circuit and the neutralizing adjustment manipulated for an indication of minimum r-f voltage in the plate tank circuit. This adjustment is normally accomplished with input and output circuits resonated and with a suitable dummy load connected to the amplifier.

Plate (and screen) voltage should be completely removed by actually opening the d-c plate-current return. If a direct-current return circuit exists, a small amount of plate current will flow when grid excitation is applied, even though no high voltage exists on the amplifier stage. Once neutralization has been established, a more accurate check may be made by applying high voltage, and tuning and loading the amplifier while noting if maximum grid and screen current occur at the same point of tuning on the plate circuit tuning capacitor as minimum plate current. As the plate tuning capacitor is detuned slightly from resonance on either side, plate current should rise, and the grid (or screen) current on the stage should decrease smoothly without any sudden jumps on either side of the resonance point. This technique will be found to be a very precise indication of accurate neutralization so long as the amplifier stage is coupled to a load which presents a resistive impedance at the operating frequency.

Neutralization of Screen-Grid R-F Amplifiers Radio-frequency amplifiers using screen-grid tubes can be operated without any additional provision for

neutralization at frequencies up to about 15 MHz, provided adequate shielding has been provided between the input and output circuits. Special vhf screen-grid and beam tetrode tubes such as the 2E26, 6146, and 5516 in the low-power category and 4E27A, 4-65A, 4-125A, and 4-250A in the medium-power category can frequently be operated at frequencies as high as 50 MHz without any additional provision for neutralization. Tubes such as the 807, 7094, and 813 can be operated with good circuit design at frequencies up to 30 MHz without any additional provision for neutralization. The 829 tube has been found to require neutralization in many cases above 20 MHz although the 832A tube will operate quite stably at 100 MHz without neutralization.

None of these tubes, however, has perfect shielding between the grid and the plate, a condition brought about by the inherent inductance of the screen leads within the tube itself. In addition, unless "watertight" shielding is used between the grid and plate circuits of the tube a certain amount of ex-

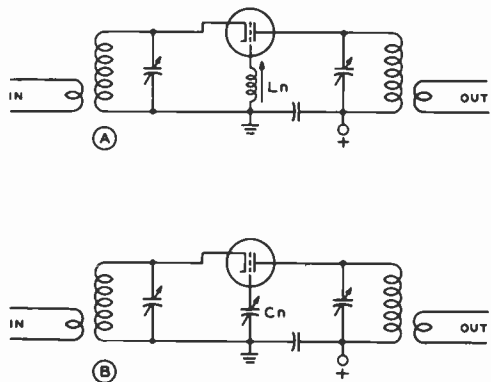

Figure 22

NEUTRALIZATION OF GRID LEAD INDUCTANCE

A—When amplifier is operated below self-neutralizing frequency of tube (h-f range, for example) additional inductance (L_n) in grid-return lead may be required to achieve complete neutralization of amplifier.

B—When amplifier is operated above self-neutralizing frequency of tube (the vhf range, for example) grid inductance is compensated by addition of series capacitance which is adjusted to minimize interaction between input and output circuits of amplifier.

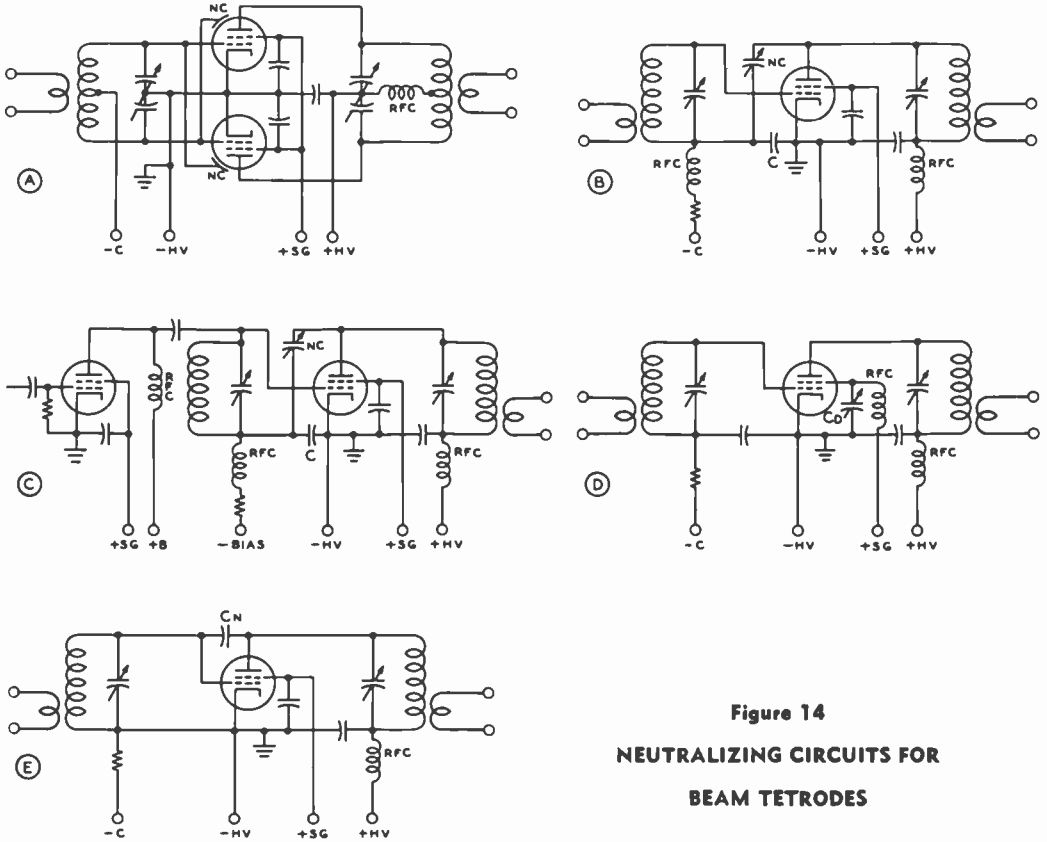

Figure 14
NEUTRALIZING CIRCUITS FOR
BEAM TETRODES

A conventional cross-neutralized circuit for use with push-pull beam tetrodes is shown at A. The neutralizing capacitors (NC) usually consist of small plates or rods mounted alongside the plate elements of the tubes. B and C show grid-neutralized circuits for use with a single-ended tetrode having either link coupling or capacitive coupling into the grid tank. D shows a method of tuning the screen-lead inductance to accomplish neutralization in a single-ended vhf tetrode amplifier, while E shows a method of neutralization by increasing the grid-to-plate capacitance on a tetrode when the operating frequency is higher than that frequency where the tetrode is "self-neutralized" as a result of series resonance in the screen lead. Methods D and E normally are not practicable at frequencies below about 50 MHz with the usual types of beam tetrode tubes.

ternal leakage between the two circuits is present. These difficulties may not be serious enough to require neutralization of the stage to prevent oscillation, but in many instances they show up in terms of key-clicks when the stage in question is keyed, or as parasitics when the stage is modulated. Unless the designer of the equipment can carefully check the tetrode stage for miscellaneous feedback between the grid and plate circuits, and make the necessary circuit revisions to reduce this feedback to an absolute minimum, it is wise to neutralize the tetrode just as if it were a triode tube.

In most push-pull tetrode amplifiers the simplest method of accomplishing neutralization is to use the cross-neutralized capacitance bridge arrangement as normally employed with triode tubes. The neutralizing capacitances, however, must be very much smaller than used with triode tubes, values of the order of 0.2 pf normally being required with beam tetrode tubes. This order of capacitance is far less than can be obtained with a conventional neutralizing capacitor at minimum setting, so the neutralizing arrangement is most commonly made especially for the case at hand. Most

common procedure is to bring a conductor (connected to the opposite grid) in the vicinity of the plate itself or of the plate tuning capacitor of one of the tubes. Either one or two such capacitors may be used, two being normally used on a higher-frequency amplifier in order to maintain balance within the stage.

An example of this is shown in figure 23A.

Neutralizing Single-Ended Tetrode Stages A single-ended tetrode r-f amplifier stage may be neutralized in the same manner as illustrated for a push-pull stage in figure 23A, provided a split-stator tank capacitor is in use in the plate circuit. However, in the majority of single-ended tetrode r-f amplifier stages a single-section capacitor is used in the plate tank. Hence, other neutralization procedures must be employed when neutralization is found necessary.

The circuit shown in figure 23B is not a true neutralizing circuit, in that the plate-to-grid capacitance is not balanced out. However, the circuit can afford the equivalent effect by isolating the high resonant impedance of the grid-tank circuit from the energy fed back from plate to grid. When NC and C are adjusted to bear the following ratio to the grid-to-plate capacitance and the total capacitance from grid-to-ground in the output tube,

$$\frac{NC}{C} = \frac{C_{gp}}{C_{gk}}$$

both ends of the grid tank circuit will be at the same voltage with respect to ground as a result of r-f energy fed back to the grid circuit. This means that the impedance from grid to ground will be effectively equal to the reactance of the grid-to-cathode capacitance in parallel with the stray grid-to-ground capacitance, since the high resonant impedance of the tuned circuit in the grid has been effectively isolated from the feedback path. It is important to note that the effective grid-to-ground capacitance of the tube being neutralized includes the rated grid-to-cathode or input capacitance of the tube, the capacitance of the socket, wiring capacitances and other strays, but it does *not*

include the capacitances associated with the grid-tuning capacitor. Also, if the tube is being excited by capacitive coupling from a preceding stage (as in figure 23C), the effective grid-to-ground capacitance includes the output capacitance of the preceding stage and its associated socket and wiring capacitances.

Cancellation of Screen-Lead Inductance The provisions discussed in the previous paragraphs are for neutralization of the small (though still important at the higher frequencies) grid-to-plate capacitance of beam-tetrode tubes. However, in the vicinity of the upper frequency limit of each tube type the inductance of the screen lead of the tube becomes of considerable importance. With a tube operating at a frequency where the inductance of the screen lead is appreciable, the screen will allow a considerable amount of energy leak-through from plate to grid even though the socket terminal on the tube is carefully bypassed to ground. This condition takes place even though the socket pin is bypassed since the reactance of the screen lead will allow a moderate amount of r-f potential to appear on the screen itself inside the electrode assembly in the tube. This effect has been reduced to a very low amount in such tubes as the 4CX250B, 8122, and 4CX1000K, but it is still quite appreciable in most beam-tetrode tubes.

The effect of screen-lead inductance on the stability of a stage can be eliminated at any particular frequency by one of two methods. These methods are: (1) Tuning out the screen-lead inductance by series-resonating the screen-lead inductance with a capacitor to ground. This method is illustrated in figure 23D and is commonly employed in commercially built equipment for operation on a narrow frequency band in the range above about 75 MHz. The other method (2) is illustrated in figure 23E and consists in feeding back additional energy from plate to grid by means of a small capacitor connected between these two elements. Note that this capacitor is connected in such a manner as to *increase* the effective grid-to-plate capacitance of the tube. This method has been found to be effective with 6146 tubes in the range above 50 MHz and

with tubes such as the 4-125A and 4-250A in the vicinity of their upper frequency limits.

Note that both these methods of stabilizing a beam-tetrode vhf amplifier stage by cancellation of screen-lead inductance are suitable only for operation over a relatively narrow band of frequencies in the vhf range. At lower frequencies both these expedients for reducing the effects of screen-lead inductance will tend to increase the tendency toward oscillation of the amplifier stage.

Neutralizing Problems When a stage cannot be completely neutralized, the difficulty usually can be traced to one or more of the following causes: (1) Filament leads not bypassed to the common ground of that particular stage. (2) Ground lead from the rotor connection of the split-stator tuning capacitor to filament open or too long. (3) Neutralizing capacitors in a field of excessive r.f. from one of the tuning coils. (4) Electromagnetic coupling between grid and plate coils, or between plate and preceding buffer or oscillator circuits. (5) Insufficient shielding or spacing between stages, or between grid and plate circuits in compact transmitters. (6) Shielding placed too close to plate-circuit coils, causing induced currents in the shields. (7) Parasitic oscillations when plate voltage is applied. The cure for the latter is mainly a matter of cut and try—rearrange the parts, change the length of grid, plate, or neutralizing leads, insert a parasitic choke in the grid lead or leads, or eliminate the grid r-f chokes which may be the cause of a low-frequency parasitic (in conjunction with plate r-f chokes).

11-7 Grounded-Grid Amplifiers

Certain triodes such as the 3-400Z have a grid structure and lead arrangement which result in a very low plate-to-filament capacitance when the grid is grounded, the grid acting as an effective shield much in the manner of the screen of a tetrode tube. By connecting such a triode in the typical circuit of figure 24 taking the usual precautions against stray capacitive and inductive

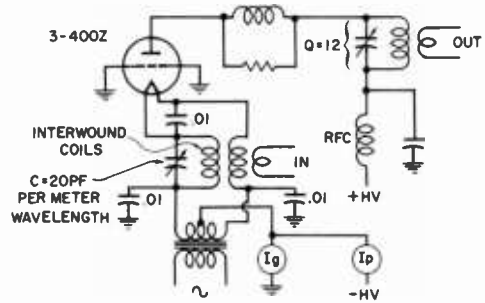

Figure 24

GROUNDING-GRID AMPLIFIER

This type of triode amplifier requires no neutralization, and is very popular as a zero-bias class-B linear stage for SSB service.

coupling between input and output circuits, a stable power amplifier is realized which requires no neutralization in the hf region. A high- μ triode may not require grid bias to operate in the class-B mode, however, some amount of grid bias may be added to achieve class-C operation.

The *grounded-grid* (cathode-driven) amplifier requires considerably more excitation than if the same tube were employed in a conventional grounded-cathode circuit. The additional drive power required to drive a tube in a grounded-grid circuit is not lost, however, as it shows up in the output circuit and adds to the power delivered to the load. Nevertheless it means that a larger driver stage is required for an amplifier of given output power as a portion of the drive power is delivered to the load (*feedthrough power*). Stage gains of 10 to 12 decibels are common in grounded-grid circuits.

Some tetrodes may be strapped as triodes (screen and grid grounded) and operated as class-B grounded-grid tubes. Data on this class of operation may often be obtained from the tube manufacturer.

11-8 Frequency Multipliers

Quartz crystals and variable-frequency oscillators are not ordinarily used for direct control of the output of high-frequency

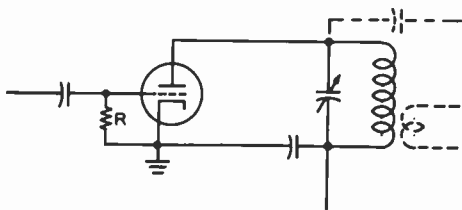

Figure 25

CONVENTIONAL TRIODE FREQUENCY MULTIPLIER

Small triodes such as the 6C4 operate satisfactorily as frequency multipliers, and can deliver output well into the vhf range. Resistor R normally will have a value in the vicinity of 100,000 ohms.

transmitters. *Frequency multipliers* are often employed to multiply the frequency to the desired value. The multipliers operate on exact multiples of the excitation frequency; a 3.6-MHz crystal oscillator can be made to control the output of a transmitter on 7.2 or 14.4 MHz, or on 28.8 MHz, by means of one or more frequency multipliers. When used at twice frequency, they are often termed *frequency doublers*. A simple doubler circuit is shown in figure 25. It consists of a vacuum tube with its plate circuit tuned to *twice* the frequency of the grid-driving circuit.

Doubling is best accomplished by operating the tube with high grid bias. The grid circuit is driven approximately to the normal value of d-c grid current through the r-f choke and grid resistor, shown in figure 25. The resistance value generally is from two to five times as high as that used with the same tube for straight amplification. Consequently, the grid bias is several times as high for the same value of grid current.

Neutralization is seldom necessary in a doubler circuit, since the plate is tuned to twice the frequency of the grid circuit. The impedance of the grid-driving circuit is very low at the doubling frequency, and thus there is little tendency for self-excited oscillation.

Frequency doublers require bias of several times cutoff; high- μ tubes therefore are desirable for this type of service. Tubes which have amplification factors from 20 to 200

are suitable for doubler circuits. Tetrodes and pentodes make excellent doublers.

Angle of Flow in Frequency Multipliers The angle of plate-current flow in a frequency multiplier is a very important factor in determining the plate efficiency. As the angle of flow is decreased for a given value of grid current, the efficiency increases. To reduce the angle of flow, higher grid bias is required so that the grid excitation voltage will exceed the cutoff value for a shorter portion of the exciting-voltage cycle. For a high order of efficiency, frequency doublers should have an angle of flow of 90 degrees or less, triplers 60 degrees or less, and quadruplers 45 degrees or less. Under these conditions the efficiency will be on the same order as the reciprocal of the harmonic on which the stage operates. In other words the efficiency of a doubler will be approximately $\frac{1}{2}$ or 50 percent, the efficiency of a tripler will be approximately $\frac{1}{3}$ or 33 percent and that of a quadrupler will be about 25 percent.

The pulses ABC, EFG, and JKL in figure 26 illustrate 180-degree excitation pulses under class-B operation, the solid straight line indicating cutoff bias. If the bias is increased by N times, to the value indicated by the dotted straight line, and the excitation increased until the peak r-f voltage with respect to ground is the same as before, then the excitation frequency can be cut in half and the effective excitation pulses will have almost the same shape as before. The only difference is that every other pulse is missing; MNO simply shows where the missing pulse would go. However, if the Q of the plate tank circuit is high, it will have sufficient *flywheel effect* to carry over through the missing pulse, and the only effect will be that the plate input and r-f output at optimum loading drop to approximately half. As the input frequency is half the output frequency, an efficient frequency doubler is the result.

By the same token, a tripler or quadrupler can be analyzed, the tripler skipping two excitation pulses and the quadrupler three. In each case the excitation pulse ideally should be short enough that it does not exceed 180 degrees at the output frequency; otherwise the excitation actually is *bucking* the output over a portion of the cycle.

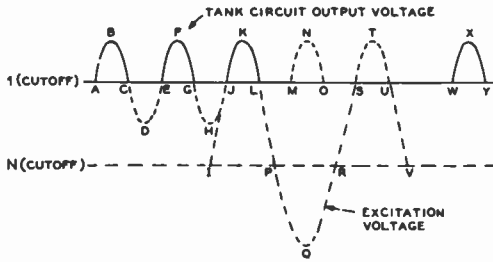

Figure 26

ILLUSTRATING THE ACTION OF A FREQUENCY DOUBLER

Push-Push Multipliers Two tubes can be connected in parallel to give twice the output of a single-tube doubler. If the grids are driven *out* of phase instead of *in* phase, the tubes then no longer work simultaneously, but rather one at a time. The effect is to fill in the missing pulses (figure 26). Not only is the output doubled, but several advantages accrue which cannot be obtained by straight parallel operation.

Chief among these is the effective neutralization of the fundamental and all *odd* harmonics, an advantage when spurious emissions must be minimized. Another advantage is that when the available excitation is low and excitation pulses exceed 90 degrees, the output and efficiency will be greater than for the same tubes connected in parallel.

The same arrangement may be used as a quadrupler, with considerably better efficiency than for straight parallel operation, because seldom is it practicable to supply sufficient excitation to permit 45-degree excitation pulses. As pointed out above, the push-push arrangement exhibits better efficiency than a single-ended multiplier when excitation is inadequate for ideal multiplier operation. A typical push-push doubler is illustrated in figure 27.

Push-Pull Frequency Triplers It is frequently desirable in the case of uhf and vhf transmitters that frequency multiplication stages be balanced with respect to ground. Further it is just as easy in most cases to multiply the crystal or vfo frequency by powers of three rather than multiplying by powers of two as is frequently done in lower-frequency trans-

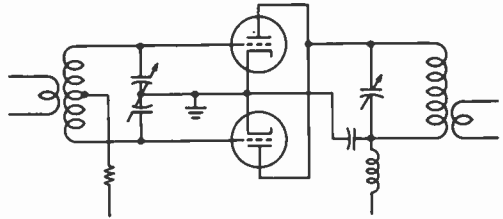

Figure 27

PUSH-PUSH FREQUENCY DOUBLER

The output of a doubler stage may be materially increased through the use of a push-push circuit such as illustrated above.

mitters. Hence the use of push-pull triplers has become quite prevalent in both commercial and amateur vhf and uhf transmitter designs. Such stages are balanced with respect to ground and appear in construction and on paper essentially the same as a push-pull r-f amplifier stage with the exception that the output tank circuit is tuned to three times the frequency of the grid-tank circuit. A circuit for a push-pull tripler stage is shown in figure 28.

A push-pull tripler stage has the further advantage in amateur work that it can also be used as a conventional push-pull r-f amplifier merely by changing the grid and plate coils so that they tune to the same frequency. This is of some advantage in the case of operating the 50-MHz band with 50-MHz excitation, and then changing the

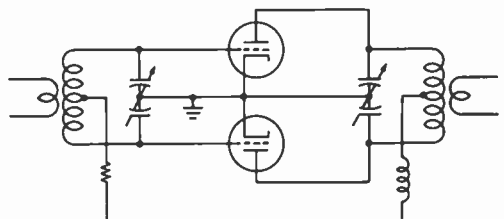

Figure 28

PUSH-PULL FREQUENCY TRIPLER

The push-pull tripler is advantageous in the vhf range since circuit balance is maintained both in the input and output circuits. If the circuit is neutralized it may be used either as a straight amplifier or as a tripler. Either triodes or tetrodes may be used; dual-unit tetrodes such as the 6360, 832A, and 829B are particularly effective in the vhf range.

plate coil to tune to 144 MHz for operation of the stage as a tripler from excitation on 48 MHz.

11-9 Tank-Circuit Capacitances

It is necessary that the proper value of Q be used in the plate tank circuit of any r-f amplifier. The following section has been devoted to a treatment of the subject, and charts are given to assist the reader in the determination of the proper LC ratio to be used in a radio-frequency amplifier stage.

A class-C amplifier draws plate current in the form of very distorted pulses of short duration. Such an amplifier is always operated into a tuned inductance-capacitance or tank circuit which tends to smooth out these pulses, by its storage or tank action, into a sine wave of radio-frequency output. Any waveform distortion of the carrier frequency results in harmonic interference in higher-frequency channels.

A class-A r-f amplifier would produce a sine wave of radio-frequency output if its exciting waveform were also a sine wave. However, a class-A amplifier stage converts its d-c input to r-f output by acting as a variable resistance, and therefore heats considerably. A class-B or C amplifier driven hard with short pulses at the peak of the exciting waveform acts more as an electronic switch, and therefore can convert its d-c input to r-f output with relatively good efficiency.

Tank Circuit Q As stated before, the tank circuit of a class-C amplifier receives energy in the form of short pulses of plate current which flow in the amplifier tube. But the tank circuit must be able to store enough energy so that it can deliver a current essentially sine wave in form to the load. The ability of a tank to store energy in this manner may be designated as the effective Q of the tank circuit. The effective circuit Q may be stated in any of several ways, but essentially the Q of a tank circuit is the ratio of the energy stored to 2π times the energy lost per cycle. Further, the energy lost per cycle must, by definition, be equal

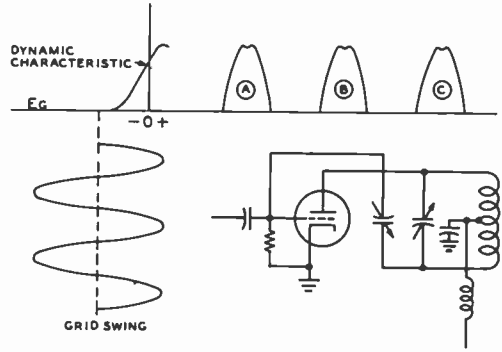

Figure 29

CLASS-C AMPLIFIER OPERATION

Plate current pulses are shown at A, B, and C. The dip in the top of the plate current waveform will occur when the excitation voltage is such that the minimum plate voltage dips below the maximum grid voltage. A detailed discussion of the operation of class-C amplifiers is given in Chapter Seven.

to the energy delivered to the tank circuit by the class-B or C amplifier tube or tubes.

The Q of a tank circuit at resonance is equal to its parallel-resonant impedance (the resonant impedance is resistive at resonance) divided by the reactance of either the capacitor or the inductor which go to make up the tank. The inductive reactance is equal to the capacitive reactance, by definition, at resonance. Hence we may state:

$$Q = \frac{R_L}{X_C} = \frac{R_L}{X_L}$$

where,

R_L is the resonant impedance of the tank,
 X_C is the reactance of the tank capacitor,
 X_L is the reactance of the tank coil.

This value of resonant impedance (R_L) is the load which is presented to the class-C amplifier tube in a single-ended circuit such as shown in figure 29.

The value of load impedance (R_L) which the class-B/C amplifier tube sees may be obtained, looking in the other direction from the tank coil, from a knowledge of the operating conditions on the class-B/C tube. This load impedance may be obtained from the

following expression, which is true in the general case of any class-B/C amplifier:

$$R_L = \frac{(e_p \text{ max})^2}{1.8 \times N_p \times I_b \times E_b}$$

where the values in the equation have the characteristics listed in the beginning of Chapter 7.

The expression is academic, since the peak value of the fundamental component of plate voltage swing ($e_p \text{ max}$) is not ordinarily known unless a high-voltage peak a-c voltmeter is available for checking. Also, the decimal value of plate-circuit efficiency is not ordinarily known with any degree of accuracy. However, in a *normally operated* class-B/C amplifier the plate voltage swing will be approximately equal to 0.85 to 0.9 times the d-c plate voltage on the stage, and the plate-circuit efficiency will be from 70 to 80 percent (N_p of 0.7 to 0.8), the higher values of efficiency normally being associated with the higher values of plate voltage swing. With these two assumptions as to the normal class-B/C amplifier, the expression for the plate load impedance can be greatly simplified to the following approximate expression, which also applies to class-AB₁ stages:

$$R_L \sim \frac{R_{d.c.}}{1.8}$$

which means simply that the resistance presented by the tank circuit to the class-B/C tube is *approximately* equal to one-half the d-c load resistance which the class-C stage

presents to the power supply (and also to the modulator in case high-level modulation of the stage is to be used).

Combining the above simplified expression for the r-f impedance presented by the tank to the tube, with the expression for tank Q given in a previous paragraph we have the following expression which relates the reactance of the tank capacitor or coil to the d-c input to the class-B/C stage:

$$X_C = X_L \sim \frac{R_{d.c.}}{2 Q}$$

The foregoing expression is the basis of the usual charts giving tank capacitance for the various bands in terms of the d-c plate voltage and current to the class-B/C stage, including the chart of figure 31.

Harmonic Radiation versus Q The problem of harmonic radiation from transmitters has long been present, but it has become critical during the past decades along with the extensive occupation of the vhf range. Television signals are particularly susceptible to interference from other signals falling within the passband of the receiver, so that the TVI problem has received the major emphasis of all the services in the vhf range which are susceptible to interference from harmonics of signals in the hf or lower-vhf range.

Inspection of figure 30 will show quickly that the tank circuit of an r-f amplifier should have an operating Q of 10 or greater to afford satisfactory rejection of second-harmonic energy. The curve begins to straighten out above a Q of about 15, so that a considerable increase in Q must be made before an appreciable reduction in second-harmonic energy is obtained. Above a circuit Q of about 10 any increase will not afford appreciable reduction in the third-harmonic energy, so that additional harmonic filtering circuits external to the amplifier proper must be used if increased attenuation of higher-order harmonics is desired. The curves also show that push-pull amplifiers may be operated at Q values of 6 or so, since the second harmonic is cancelled to a large extent if there is no unbalanced coupling between the output tank circuit and the antenna system.

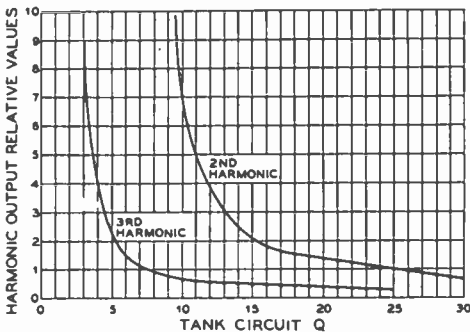

Figure 30

RELATIVE HARMONIC OUTPUT
PLOTTED AGAINST TANK CIRCUIT Q

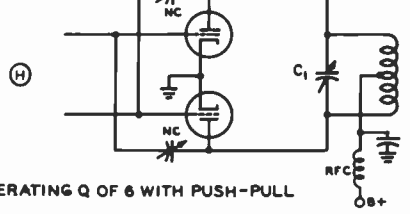
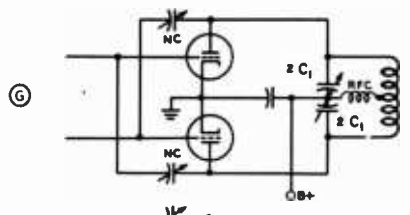
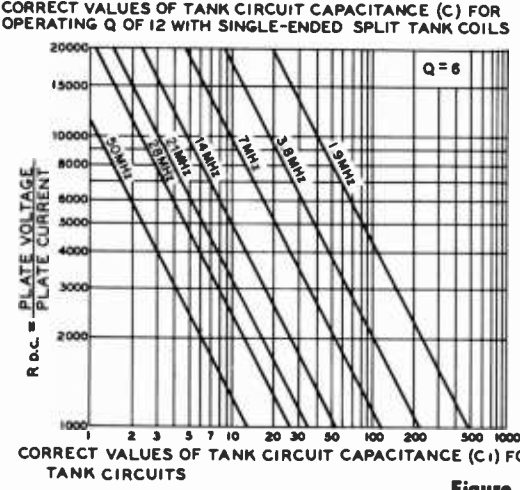
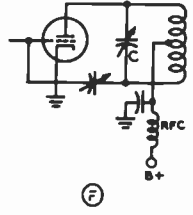
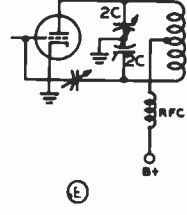
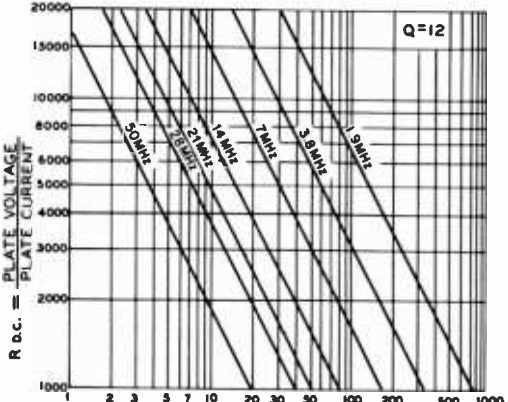
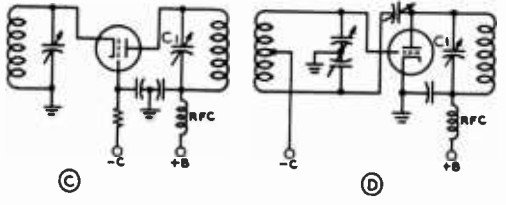
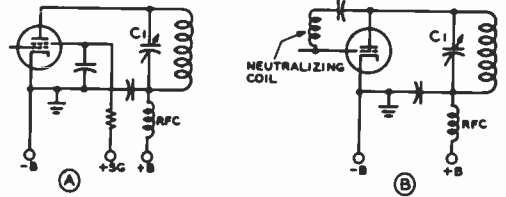
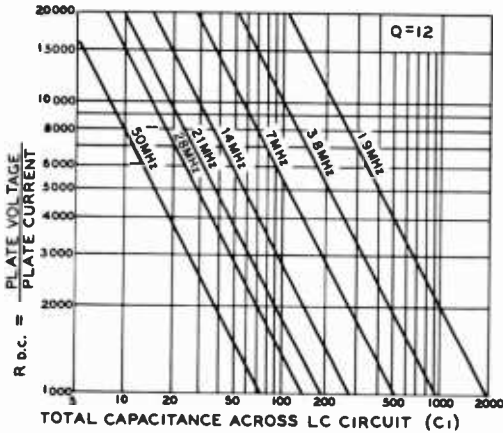

Figure 31

PLATE-TANK CIRCUIT ARRANGEMENTS

Shown above in the case of each of the tank-circuit types is the recommended circuit capacitance. Chart capacitance C₁ represents actual circuit values for configurations A, B, C, and D. Capacitance C represents the value of each section of split-stator capacitor of figure E, and twice the value of figure F. Indicated capacitance is twice the value of each section of the capacitor of figure G and four times the value of the capacitance of figure H.

Capacity Charts for Optimum Tank Q

Figure 31 illustrates the correct value of tank capacitance for various circuit configurations. A Q value of 12 has been chosen as optimum for single-ended circuits, and a value of 6 has been chosen for push-pull-circuits. Figures 31A-D are used when a single-ended stage is employed, and the capacitance values given are for the total capacitance across the tank coil. This value includes the tube interelectrode capacitance (plate to ground), coil distributed capacitance, wiring capacitance, and the value of any low-inductance plate-to-ground bypass capacitor as used for reducing harmonic generation, in addition to the actual "in-use" capacitance of the plate tuning capacitor. Total circuit stray capacitance may vary from perhaps 5 picofarads for a vhf stage to 30 picofarads for a medium-power tetrode h-f stage. For a given value of plate voltage-to-plate current ratio, doubling the capacitance shown doubles the Q. When a split plate-tank coil is employed, the circuits of figures 31E-F are used. In the case of the split-stator capacitor (E), the capacitance of each section should have a value equal to that shown by the chart. In the case of the single-section capacitor (F), the capacitance should be equal to twice the value shown by the chart.

For push-pull operation, the correct values of tank-circuit capacitance are shown in the illustrations G and H. Each section of the split-stator capacitor should have a value equal to twice that value shown by the graph. In the case of the single-section capacitor, the capacitance should be equal to that value shown by the chart.

The tank circuit operates in the same manner whether the tube feeding it is pentode, beam tetrode, neutralized triode, grounded-grid triode; whether it is single-ended or push-pull; or whether it is shunt-fed or series-fed. The important thing in establishing the operating Q of the tank circuit is the ratio of the loaded resonant impedance across its terminals to the reactance of the L and the C which make up the tank.

Due to the unknowns involved in determining circuit stray capacitances it is sometimes more convenient to determine the value of L required for the proper circuit Q (by the method discussed earlier in this Sec-

Figure 32

Air-gap in inches	Peak voltage breakdown
.030	1000
.050	2000
.070	3000
.100	4000
.125	4500
.150	5200
.170	6000
.200	7500
.250	9000
.350	11,000
.500	15,000
.700	20,000

Recommended air-gap for use when no d-c voltage appears across plate tank capacitor (when plate circuit is shunt fed, or when the plate tank capacitor is insulated from ground).

D-C plate voltage	C-W	Plate mod.
400	.030	.050
600	.050	.070
750	.050	.084
1000	.070	.100
1250	.070	.144
1500	.078	.200
2000	.100	.250
2500	.175	.375
3000	.200	.500
3500	.250	.600

Spacings should be multiplied by 1.5 for same safety factor when d-c voltage appears across plate tank capacitor.

tion) and then to vary the tuned-circuit capacitance until resonance is reached. This method is most frequently used in obtaining proper circuit Q in commercial transmitters.

The values of R_p for using the charts are easily calculated by dividing the d-c plate-supply voltage by the total d-c plate current (expressed in amperes). Correct values of total tuning capacitance are shown in the chart for the different amateur bands. The shunt stray capacitance can be estimated closely enough for all practical purposes. The coil inductance should then be chosen which will produce resonance at the desired frequency with the total calculated tuning capacitance.

Effect of Loading on Q

The Q of a circuit depends on the resistance in series with the capacitance and inductance. This series resistance is very low for a low-loss coil not loaded by an antenna circuit. The value of Q may be from 100 to 400 under these conditions. Coupling an antenna circuit has the effect of increasing the series resistance, though in this case the power is consumed as useful radiation by the antenna. Mathematically, the antenna increases

the value of R in the expression $Q = \omega L/R$ where L is the coil inductance in microhenrys and ω is the term $2\pi f$ (f being in MHz).

The coupling from the final tank circuit to the antenna or antenna transmission line can be varied to obtain values of Q from perhaps 3 at maximum coupling to a value of Q equal to the unloaded Q of the circuit at zero antenna coupling. This value of unloaded Q can be as high as 400, as mentioned in the preceding paragraph. However, the value of $Q = 12$ will not be obtained at values of normal d-c plate current in the class-C amplifier stage unless the C-to-L ratio in the tank circuit is correct for that frequency of operation.

Tuning Capacitor Air Gap To determine the required tuning-capacitor air gap for a particular amplifier

circuit it is first necessary to estimate the peak r-f voltage which will appear between the plates of the tuning capacitor. Then, using figure 32, it is possible to estimate the plate spacing which will be required.

The instantaneous r-f voltage in the plate circuit of a class-C amplifier tube varies from nearly zero to nearly twice the d-c plate voltage. If the d-c voltage is being 100 percent modulated by an audio voltage, the r-f peaks will reach nearly four times the d-c voltage.

These rules apply to a loaded amplifier or buffer stage. If either is operated without an r-f load, the peak voltages will be greater and can *exceed* the d-c plate supply voltage. For this reason no amplifier should be operated without load when anywhere near normal d-c plate voltage is applied.

If a plate blocking capacitor is used, it must be rated to withstand the d-c plate voltage plus any audio voltage. This capacitor should be rated at a d-c working voltage of at least *twice the d-c plate supply in a plate-modulated amplifier*, and at least *equal to the d-c supply* in any other type of r-f amplifier.

11-10 L- and Pi-Matching Networks

The *L*- and *pi*-networks often can be put to advantageous use in accomplishing an impedance match between two differing im-

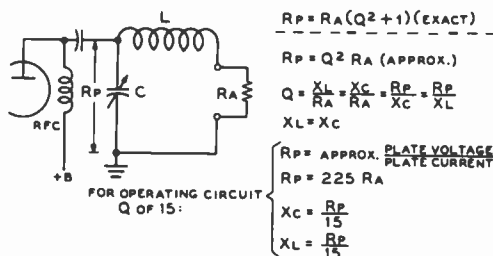

Figure 33

THE L-NETWORK IMPEDANCE TRANSFORMER

The *L*-network is useful with a moderate operating Q for high values of impedance transformation, and it may be used for applications other than in the plate circuit of a tube with relatively low values of operating Q for moderate impedance transformations. Exact and approximate design equations are given.

pedances. Common applications are the matching between a transmission line and an antenna, or between the plate circuit of a single-ended amplifier stage and an antenna transmission line. Such networks may be used to accomplish a match between the plate tank circuit of an amplifier and a transmission line, or they may be used to match directly from the plate circuit of an amplifier to the line without the requirement for a tank circuit—provided the network is designed in such a manner that it has sufficient operating Q for accomplishing harmonic attenuation.

The L-Matching Network The *L*-network is of limited utility in impedance match-

ing since its ratio of impedance transformation is fixed at a value equal to $(Q^2 + 1)$. The operating Q may be relatively low (perhaps 3 to 6) in a matching network between the plate *tank circuit* of an amplifier and a transmission line; hence impedance transformation ratios of 10 to 1 and even lower may be attained. But when the network also acts as the plate tank circuit of the amplifier stage, as in figure 33, the operating Q should be at least 12 and preferably 15. An operating Q of 15 represents an impedance transformation of 225; this value normally will be too high even for transforming from the 2000- to 10,000-ohm plate impedance of a class-C amplifier

stage down to a 50-ohm transmission line.

However, the L-network is interesting since it forms the basis of design for the pi-network. Inspection of figure 33 will show that the L-network in reality must be considered as a parallel-resonant tank circuit in which R_A represents the coupled-in load resistance; only in this case the load resistance is directly coupled into the tank circuit rather than being inductively coupled as in the conventional arrangement where the load circuit is coupled to the tank circuit by means of a link. When R_A is shorted, L and C comprise a conventional parallel-resonant tank circuit, since for proper operation L and C must be resonant in order for the network to present a resistive load to the class-C amplifier.

The Pi-Network The *pi impedance-matching network*, illustrated in figure 34, is much more general in its application than the L network since it offers greater harmonic attenuation, and since it can be used to match a relatively wide range of impedances while still maintaining any desired operating Q . The values of C_1 and L_1 in the pi-network of figure 34 can be thought of as having the same values of the L network in figure 33 for the same operating Q , but, what is more important from the comparison standpoint these values will be about the same as in a conventional tank circuit.

The value of the capacitance may be determined by calculation with the operating Q and the load impedance which should be

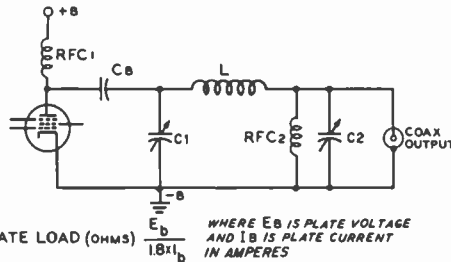

PLATE LOAD (OHMS) $\frac{E_b}{1.8I_b}$

- CB - .0025 μ F, MICA CAPACITOR RATED AT TWICE THE D.C. PLATE VOLTAGE.
- RFC1 - #28 ENAMELED, CLOSE-WOUND ON A CERAMIC INSULATOR 1" DIA., 4" LONG OR NATIONAL R-175A
- RFC2 - 2 1/2" MH, NATIONAL R-100

Estimated Plate Load (ohms)	1000	1500	2000	2500	3000	3500	4000	4500	5000	6000*	Notes
C_1 in pf, 3.5 MHz	520	360	280	210	180	155	135	120	110	90	The actual capacitance setting for C_1 equals the value in this table minus the published tube output capacitance. Air gap approx. 10 mils/100 v E_b .
7	260	180	140	105	90	76	68	60	56	45	
14	130	90	70	52	45	38	34	30	28	23	
21	85	60	47	35	31	25	23	20	19	15	
28	65	45	35	26	23	19	17	15	14	11	
L in μ h, 3.5 MHz	4.5	6.5	8.5	10.5	12.5	14	15.5	18	20	25	Inductance values are for a 50-ohm load. For a 70-ohm load, values are approx. 3% higher.
7	2.2	3.2	4.2	5.2	6.2	7	7.8	9	10	12.5	
14	1.1	1.6	2.1	2.6	3.1	3.5	3.9	4.5	5	6.2	
21	0.73	1.08	1.38	1.7	2.05	2.3	2.6	3	3.3	4.1	
28	0.55	0.8	1.05	1.28	1.55	1.7	1.95	2.5	2.5	3.1	
C_2 in pf, 3.5 MHz	2400	2100	1800	1550	1400	1250	1100	1000	900	700	For 50-ohm transmission line. Air gap for C_2 is approx. 1 mil/100 v E_b .
7	600	1060	900	760	700	630	560	500	460	350	
14	600	530	450	380	350	320	280	250	230	175	
21	400	350	300	250	230	210	185	165	155	120	
28	300	265	225	190	175	160	140	125	115	90	
C_2 in pf, 3.5 MHz	1800	1500	1300	1100	1000	900	800	720	640	500	For 70-ohm transmission line.
7	900	750	650	560	500	450	400	360	320	250	
14	450	370	320	280	250	220	200	180	160	125	
21	300	250	215	190	170	145	130	120	110	85	
28	225	185	160	140	125	110	100	90	80	65	

*Values given are approximations. All components shown in Table 1 are for a Q of 12. For other values of Q , use $\frac{Q_n}{Q_b} = \frac{C_n}{C_b}$, $\frac{Q_n}{Q_b} = \frac{L_b}{L_n}$. When the estimated plate load is higher than 5000 ohms, it is recommended that the components be selected for a circuit Q between 20 and 30.

Table 1. Components for Pi-Coupled Final Amplifiers (class AB, B, and C)

reflected to the plate of the class-C amplifier as the two known quantities—or the actual values of the capacitance may be obtained for an operating Q of 12 by reference to figure 31.

The inductive arm in the pi-network can be thought of as consisting of two inductances in series, as illustrated in figure 34.

The inductive arm in the pi-network can be thought of as consisting of two inductances in series, as illustrated in figure 28. The first portion of this inductance (L_1) is that value of inductance which would resonate with C_1 at the operating frequency—the same as in a conventional tank circuit. However, the actual value of inductance in this arm of the pi-network, L_{TOT} will be greater than L_1 for normal values of impedance transformation. For high transformation ratios L_{TOT} will be only slightly greater than L_1 ; for a transformation ratio of 1.0, L_{TOT} will be twice as great as L_1 . The amount of inductance which must be added to L_1 to restore resonance and maintain circuit Q is obtained through use of the expression for X_{L1} and X_{L2} in figure 34.

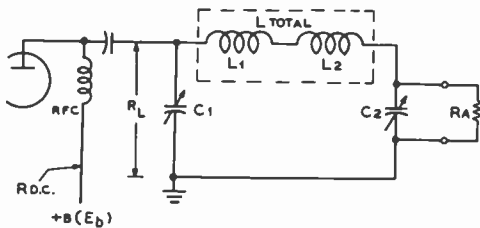

$$R_{D.C.} = \frac{E_b}{I_b}$$

$$R_p \approx \frac{R_{D.C.}}{2}$$

$$X_{C1} = \frac{R_L}{Q}$$

$$X_{L1} = \frac{R_L}{Q}$$

$$X_{C2} = -R_A \sqrt{\frac{R_L}{R_A(Q^2 + 1)} - R_L}$$

$$X_{L2} = -\frac{R_A^2 X_{C2}}{R_A^2 + X_{C2}^2}$$

$$X_{L_{TOT.}} = X_{L1} + X_{L2}$$

Figure 34

THE PI-NETWORK

The pi-network is valuable for use as an impedance transformer over a wide ratio of transformation values. The operating Q should be at least 12 when the circuit is to be used in the plate circuit of a class-C amplifier. Design equations are given above. Inductor L_{TOT} represents a single inductance, usually variable, with a value equal to the sum of L and L_2 .

The peak voltage rating of the main tuning capacitor (C_1) should be the normal value for a class-C amplifier operating at the plate voltage to be employed. The inductor (L_{TOT}) may be a plug-in coil which is changed for each band of operation, or some sort of variable inductor may be used. A continuously variable slider-type variable inductor may be used to good advantage if available, or a tapped inductor may be employed. However, to maintain good circuit Q on the higher frequencies when a variable or tapped coil is used on the lower frequencies, the tapped or variable coil should be removed from the circuit and replaced by a smaller coil which has been especially designed for the higher frequency ranges.

The peak voltage rating of the output or loading capacitor (C_2) is determined by the power level and the impedance to be fed. If a 50-ohm coaxial line is to be fed from the pi-network, receiving-type capacitors will be satisfactory even up to the power level of a plate-modulated kilowatt amplifier. In any event, the peak voltage which will be impressed across the output capacitor is expressed by:

$$e_p = \sqrt{2 \times R_a \times P_o}$$

where,

e_p is the peak voltage across the capacitor,
 R_a is the value of resistive load which the network is feeding,
 P_o is the maximum value of the average power output of the stage.

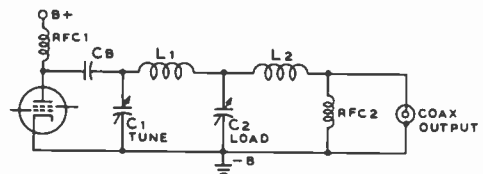

PLATE LOAD (OHMS) = $\frac{E_b}{2 \times I_b}$ WHERE E_b IS PLATE VOLTAGE AND I_b IS PLATE CURRENT IN AMPERES

- C1 - SEE TABLE I
- C2 - ONE-HALF TO TWO-THIRDS THAT VALUE OF C_2 GIVEN IN TABLE I
- L1 - 1.25 TIMES THAT VALUE OF L , GIVEN IN TABLE I
- L2 - ONE-THIRD VALUE OF L_1 , ABOVE

Figure 35. THE PI-L NETWORK

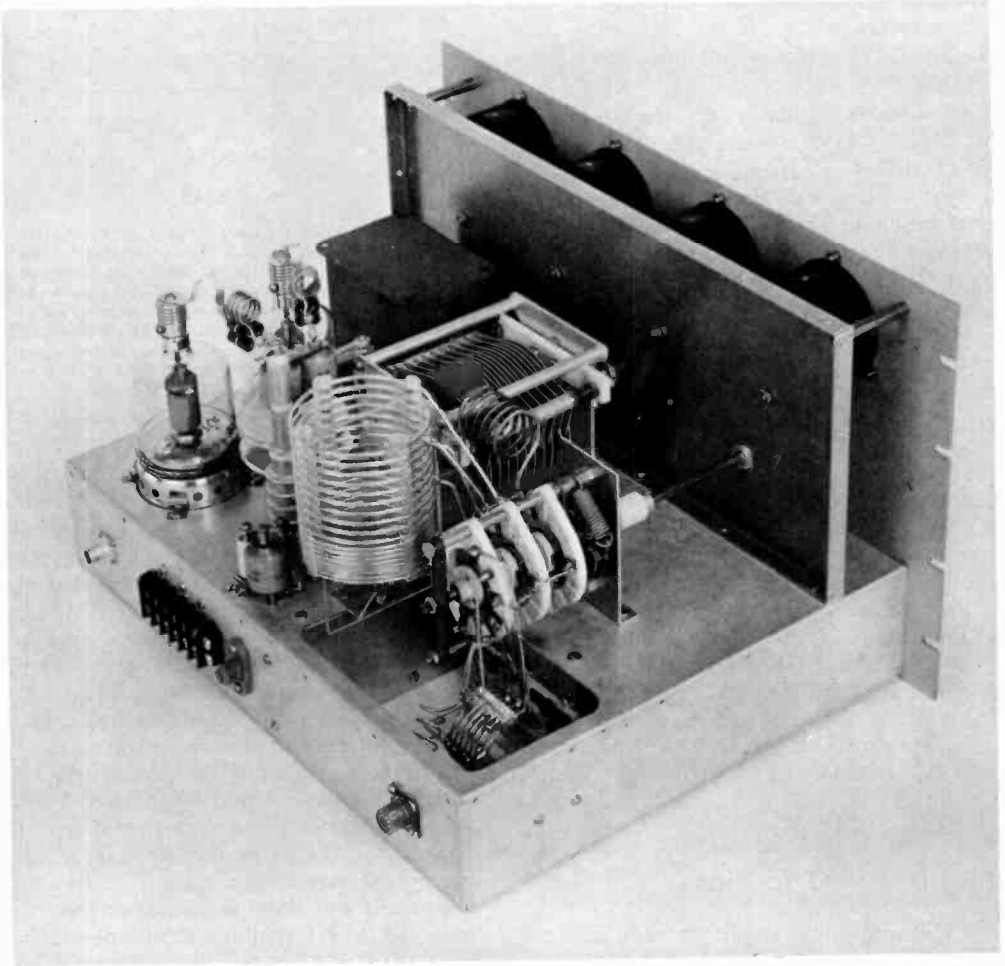

Figure 36

PI-L NETWORK PROVIDES EXTRA HARMONIC ATTENUATION

This linear amplifier makes use of a pi-L network in the plate circuit. The large vertical coil is the main portion of the pi section, with the 10-meter coil placed horizontally in front of it. The L section is placed beneath the chassis in the recessed area. A three-deck bandswitch is used: one deck for the Pi coil, one deck for the L coil and the third deck for additional 80-meter loading capacitance. A small series-tuned circuit (adjusted to TV channel 2 or 3) is placed across the coaxial antenna receptacle to provide additional harmonic protection at this band of frequencies.

The harmonic attenuation of the pi network is quite good, although an external low-pass filter will be required to obtain harmonic attenuation value upward of 100 db such as normally required. The attenuation to second-harmonic energy will be approximately 40 db for an operating Q of 15 for the pi-network; the value increases to

about 45 db for a 1:1 transformation and falls to about 38 db for an impedance step-down of 80:1, assuming that the operating Q is maintained at 15.

Component Chart for Pi-Networks To simplify design procedure, a pi-network chart is given in figure 35, summa-

rizing the calculations of figure 34 for various values of plate load impedance for class AB₁, class-B and class-C amplifiers.

The Pi-L Network The *pi-L network* shown in figure 35 will provide 10 to 15 db more attenuation of the second harmonic than will the pi, and even more attenuation to the higher harmonics. A pi-network may be converted to the pi-L configuration by reducing the loading capacitor (C_2) to about one-half to two-thirds that value required for the equivalent pi-circuit capacitor, and increasing the voltage rating by a factor of three over that minimum rating established for the pi-capacitor. The pi-section coil (L_1) will have an inductance about 1.25 times that of its pi-circuit counterpart (coil L, Table I). The L-section coil (L_2) has no equivalent in the pi-circuit and should be about one-third the inductance of the pi-section coil (L_1) as determined above. A formal calculation of the pi-L circuit parameters is given in the article "The Pi-L Plate Circuit in Kilowatt Amplifiers", by Rinaudo, *QST*, July 1962. (A free reprint of this article may be obtained by writing to: Amateur Service Department, EIMAC Division of Varian, San Carlos, California).

11-11 Grid-Bias

Radio-frequency amplifiers require some form of *grid bias* for proper operation. Practically all r-f amplifiers operate in such a manner that plate current flows in the form of short pulses which have a duration of only a fraction of an r-f cycle. To accomplish this with a sinusoidal excitation voltage, the operating grid bias must be at least sufficient to cut off the plate current. In very high efficiency class-C amplifiers the operating bias may be many times the cutoff value. Cutoff bias, it will be recalled, is that value of grid voltage which will reduce the plate current to zero at the plate voltage employed. The method for calculating it has been indicated previously. This theoretical value of cutoff will not reduce the plate current completely to zero, due to the variable- μ tendency or "knee" which is characteristic of all tubes as the cutoff point is approached.

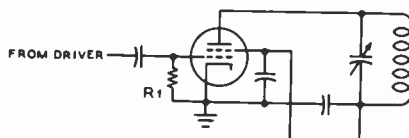

Figure 37

SELF BIAS

The grid resistor on an amplifier or multiplier stage may also be used as the shunt feed impedance to the grid of the tube when a high value of resistor (greater than perhaps 20,000 ohms) is used. When a lower value of grid resistor is to be employed, an r-f choke should be used between the grid of the tube and the grid resistor to reduce r-f losses in the grid resistance.

Class-C Bias Amplitude-modulated class-C amplifiers should be operated with the grid bias adjusted to a value greater than twice cutoff at the operating plate voltage. This procedure will ensure that the tube is operating at a bias greater than cutoff when the plate voltage is doubled on positive modulation peaks. C-w telegraph and f-m transmitters can be operated with bias as low as cutoff, if only limited excitation is available and moderate plate efficiency is satisfactory. In a c-w transmitter, the bias supply or resistor should be adjusted to the point which will allow normal grid current to flow for the particular amount of grid driving r-f power available. This form of adjustment will allow more output from the underexcited r-f amplifier than when higher bias is used with corresponding lower values of grid current. In any event, the operating bias should be set at as low a value as will give satisfactory operation, since harmonic generation in a stage increases rapidly as the bias is increased.

Self Bias A resistor can be connected in the grid circuit of a class-C amplifier to provide *self-bias*. This resistor (R_1 in figure 37), is part of the d-c path in the grid circuit.

The r-f excitation applied to the grid circuit of the tube causes a pulsating direct current to flow through the bias supply lead, due to the rectifying action of the grid, and any current flowing through R_1 produces a voltage drop across that resistor. The grid of the tube is positive for a short duration of

each r-f cycle, and draws electrons from the filament or cathode of the tube during that time. These electrons complete the circuit through the d-c grid return. The voltage drop across the resistance in the grid return provides a *negative bias* for the grid.

Self bias automatically adjusts itself over fairly wide variations of r-f excitation. The value of grid resistance should be such that normal values of grid current will flow at the maximum available amount of r-f excitation. Self bias cannot be used for grid-modulated or linear amplifiers in which the average d-c current is constantly varying with modulation.

Safety Bias Self bias alone provides no protection against excessive plate current in case of failure of the source of r-f grid excitation. A well-regulated low-voltage bias supply can be connected in series with the grid resistor as shown in figure 38. This fixed protective bias will protect the tube in the event of failure of grid excitation. "Zero-bias" tubes do not require this bias source, since their plate current will drop to a safe value when the excitation is removed.

Cathode Bias A resistor can be connected in series with the cathode or center-tapped filament lead of an amplifier to secure *automatic bias*. The plate current flows through this resistor, then back to the cathode or filament, and the voltage drop across the resistor can be applied to the grid

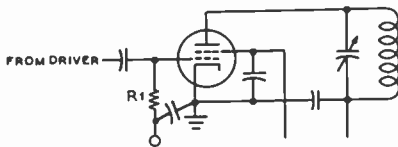

Figure 38

COMBINATION SELF- AND FIXED BIAS

Self-bias often is used in conjunction with a fixed minimum value of power supply bias. This arrangement permits the operating bias to be established by the excitation energy, but in the absence of excitation the electrode currents to the tube will be held to safe values by the fixed-minimum power supply bias. If a relatively low value of grid resistor is to be used, an r-f choke should be connected between the grid of the tube and the resistor as discussed in figure 37.

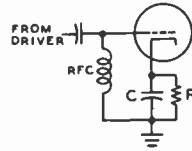

Figure 39

R-F STAGE WITH CATHODE BIAS

Cathode bias sometimes is advantageous for use in an r-f stage that operates with a relatively small amount of r-f excitation.

circuit by connecting the grid bias lead to the grounded or power-supply end of resistor R, as shown in figure 39.

The grounded (B-minus) end of the cathode resistor is negative relative to the cathode by an amount equal to the voltage drop across the resistor. The value of resistance must be so chosen that the sum of the desired grid and plate current flowing through the resistor will bias the tube for proper operation.

This type of bias is used more extensively in audio-frequency than in radio-frequency amplifiers. The voltage drop across the resistor must be subtracted from the total plate supply voltage when calculating the power input to the amplifier, and this loss of plate voltage in an r-f amplifier may be excessive. A class-A audio amplifier is biased only to approximately one-half cutoff, whereas an r-f amplifier may be biased to twice cutoff, or more, and thus the plate supply voltage loss may be a large percentage of the total available voltage when using low- or medium- μ tubes.

Often just enough cathode bias is employed in an r-f amplifier to act as safety bias to protect the tubes in case of excitation failure, with the rest of the bias coming from a grid resistor.

Separate Bias Supply An external supply often is used for grid bias, as shown in figure 33.

The bleeder resistance across the output of the filter can be made sufficiently low in value that the grid current of the amplifier will not appreciably change the amount of negative grid-bias voltage. Alternately, a voltage-regulated grid-bias supply can be used. This type of bias supply is used in class-B audio and class-

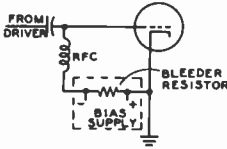

Figure 40

SEPARATE BIAS SUPPLY

A separate bias supply may be used for triodes or tetrodes. Bias is applied across a low-resistance bleeder. Grid current (if any) flowing through bleeder will boost bias voltage over nominal value of supply. Bias supply for AB₁ linear amplifier, even though no grid current is encountered, must still have low-resistance bleeder to help overcome rise in bias due to collection of primary electrons on grid of tube.

B r-f linear amplifier service where the voltage regulation in the C-bias supply is important. For a class-C amplifier, regulation is not so important, and an economical design of components in the power supply, therefore, can be utilized. In this case, the bias voltage must be adjusted with normal grid current flowing, as the grid current will raise the bias considerably when it is flowing through the bias-supply bleeder resistance.

Zener Bias A few volts of bias may be needed to reduce the zero-signal plate current of a "zero-bias" triode, particularly if the equipment is power-supply limited. A low-impedance bias source is required and the simplest way of obtaining well-regulated bias voltage is to place a zener diode in the filament or cathode return circuit (figure 41). The 1N4551, for example, has a nominal voltage drop of 4.7 volts and an impedance of 0.1 ohm, making it ideal for this service. At this value of bias, the zero-signal plate current of a 3-500Z at a plate potential of 3250 volts is reduced from 160 to approximately 90 milliamperes.

The 1N4551 diode may be bolted directly to the chassis which will act as a heat sink.

11-12 Protective Circuits for Tetrode Transmitting Tubes

The tetrode transmitting tube requires

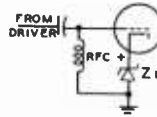

FIGURE 41

ZENER CATHODE BIAS

Zener diode may be used to obtain a few volts of well-regulated cathode bias. This circuit may be used to reduce zero-signal plate current of high- μ triodes in cathode-driven (grounded-grid) service.

three operating voltages: grid bias, screen voltage, and plate voltage. The current requirements of these three operating voltages are somewhat interdependent, and a change in potential of one voltage will affect the current drain of the tetrode in respect to the other two voltages. In particular, if the grid excitation voltage is interrupted as by keying action, or if the plate supply is momentarily interrupted, the resulting voltage or current surges in the screen circuit are apt to permanently damage the tube.

The Series Screen Supply

A simple method of obtaining screen voltage is by means of a dropping resistor from the high-voltage plate supply, as shown in figure 42. This circuit is recommended for use with low power tetrodes (6146, 5763, etc.) in class-C service. Because of poor regulation with varying screen current it should not be used in a linear amplifier stage. Since the current drawn by the screen is a function of the exciting voltage applied to the tetrode, the screen voltage will rise to equal the plate voltage under conditions of no exciting voltage. If the control grid is overdriven, on the other hand, the screen current may become excessive. In either case, damage to the screen and its associated components may result. In addition, fluctuations in the plate loading of

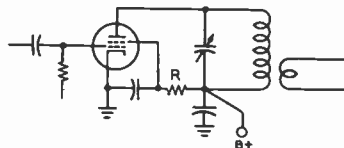

Figure 42

DROPPING-RESISTOR SCREEN SUPPLY

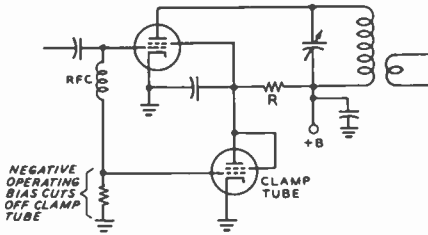

Figure 43
CLAMP-TUBE SCREEN SUPPLY

the tetrode stage will cause changes in the screen current of the tube. This will result in screen voltage fluctuations due to the inherently poor voltage regulation of the screen series dropping resistor. These effects become dangerous to tube life if the plate voltage is greater than the screen voltage by a factor of 2 or so.

The Clamp Tube A clamp tube may be added to the series screen supply, as shown in figure 43. The clamp tube is normally cut off by virtue of the d-c grid bias drop developed across the grid resistor of the tetrode tube. When excitation is removed from the tetrode, no bias appears across the grid resistor, and the clamp tube conducts heavily, dropping the screen voltage to a safe value. When excitation is applied to the tetrode the clamp tube is inoperative, and fluctuations of the plate loading of the tetrode tube could allow the screen voltage to rise to a damaging value. Because of this factor, the clamp tube does not offer complete protection to the tetrode.

The Separate Screen Supply A low-voltage screen supply may be used instead of the series screen-dropping resistor. This will protect the screen circuit from excessive voltages when the other tetrode

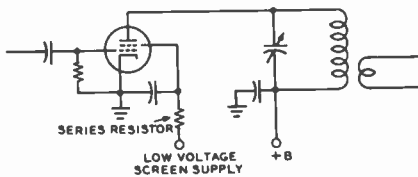

Figure 44
A PROTECTIVE WATTAGE-LIMITING RESISTOR FOR USE WITH LOW-VOLTAGE SCREEN SUPPLY

operating parameters shift. However, the screen can be easily damaged if plate or bias voltage is removed from the tetrode, as the screen current will reach high values and the screen dissipation will be exceeded. If the screen supply is capable of providing slightly more screen voltage than the tetrode requires for proper operation, a series wattage-limiting resistor may be added to the circuit as shown in figure 44. With this resistor in the circuit it is possible to apply excitation to the tetrode tube with screen voltage present (but in the absence of plate voltage) and still not damage the screen of the tube. The value of the resistor should be chosen so that the product of the voltage applied to the screen of the tetrode times the screen current never exceeds the maximum rated screen dissipation of the tube.

This circuit is not suited for linear amplifiers since the screen voltage regulation is poor.

Screen Protection In designing equipment using high-power tetrodes, consideration must be given to control of secondary emission from the screen element of the tube. The screen is normally operated at a relatively low potential to accelerate the electrons emitted from the cathode. Not all of the electrons pass through the screen grid on the way to the plate, some of them being intercepted by the grid. In the process of striking the screen grid, other electrons are emitted, some of which may be attracted by the higher potential of the plate. The result is a flow of electrons from the screen to the plate. It is possible that more electrons will leave the screen than will arrive and a screen meter will indicate a reverse electron flow, or negative screen current, under this condition. A low-impedance path to ground must be provided for this flow, otherwise the screen voltage will attempt to rise to the value of the plate voltage, by virtue of the IR drop created by the negative screen current flowing across the high-impedance screen circuit. As the screen voltage rises, the plate current of the tetrode increases and the tube is in a runaway condition. The addition of a resistor from screen to ground will compensate for the effect of negative screen current. The value of this resistor will be such that the bleed current will run from 20 ma to as high as

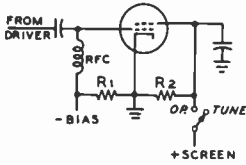

Figure 45

SCREEN CONTROL CIRCUIT

The d-c return path to ground for screen of a tetrode should not be broken. Resistor R_1 completes the circuit and screen high-voltage lead may be open to reduce stage gain for tuneup purposes.

70 ma, depending on the tube type. Tube data sheets normally state the amount of bled current required to counteract the emission current.

A correct circuit for the screen supply of a linear amplifier, including a "tune-operate" switch is shown in figure 45. In the "tune" position, screen voltage is removed, permitting adjustments to be made to the circuit at a very low power level for tuneup purposes.

Grid Protection The impedance of the grid circuit must be considered, particularly in class AB_1 amplifiers wherein a regulated bias source is required. Primary grid emission can cause trouble if the impedance of the grid circuit is too high. The d-c resistance to ground of the bias supply should be sufficiently low (below 1000 ohms or so) to prevent appreciable reverse bias from being developed by the flow of emission current through the internal resistance of the bias supply. The reverse bias produced by this effect tends to subtract from the grid bias, causing a runaway condition if not controlled.

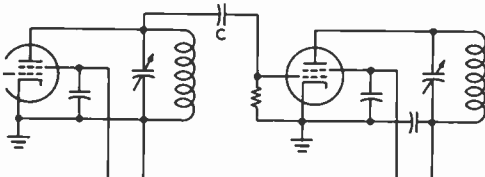

Figure 46

CAPACITIVE INTERSTAGE COUPLING

11-13 Interstage Coupling

Energy is usually coupled from one circuit of a transmitter into another either by *capacitive coupling*, *inductive coupling*, or *link coupling*. The latter is a special form of inductive coupling. The choice of a coupling method depends on the purpose for which it is to be used.

Capacitive Coupling Capacitive coupling between an amplifier or doubler circuit and a preceding driver stage is shown

in figure 46. The coupling capacitor (C) isolates the d-c plate supply from the next grid and provides a low-impedance path for the rf energy between the tube being driven and the driver tube. This method of coupling is simple and economical for low-power amplifier or exciter stages, but has certain disadvantages, particularly for high-frequency stages. The grid leads in an amplifier should be as short as possible, but this is difficult to attain in the physical arrangement of a high-power amplifier with respect to a capacitively coupled driver stage.

Disadvantages of Capacitive Coupling One significant disadvantage of capacitive coupling is the difficulty of adjusting the load on the driver stage. Impedance adjustment can be accomplished by tapping the coupling lead a part of the way down on the plate coil of the tuned stage of the driver circuit; but often when this is done a parasitic oscillation will take place in the stage being driven.

One main disadvantage of capacitive cou-

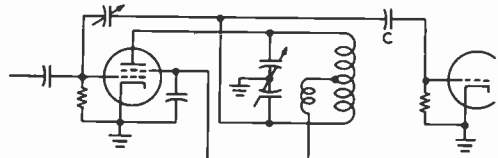

Figure 47

BALANCED CAPACITIVE COUPLING

Balanced capacitive coupling sometimes is useful when it is desirable to use a relatively large inductance in the interstage tank circuit, or where the exciting stage is neutralized as shown above.

pling lies in the fact that the grid-to-filament capacitance of the driven tube is placed directly across the driver tuned circuit. This condition sometimes makes the r-f amplifier difficult to neutralize, and the increased minimum circuit capacitance makes it difficult to use a reasonable size coil in the vhf range. Difficulties from this source can be partially eliminated by using a center-tapped or split-stator tank circuit in the plate of the driver stage, and coupling capacitively to the opposite end from the plate. This method places the plate-to-filament capacitance of the driver across one-half of the tank and the grid-to-filament capacitance of the following stage across the other half, as shown in figure 47.

Capacitive coupling, generally speaking, does not provide a high degree of attenuation to harmonics of the driving signal and its use (particularly in driver chains for vhf equipment) should be tempered caution.

Inductive Inductive coupling (figure 48) results when two coils are electromagnetically coupled to one another. The degree of coupling is controlled by varying the mutual inductance of the two coils, which is accomplished by changing the spacing or the relationship between the axes of the coils.

Inductive coupling is used extensively for coupling r-f amplifiers in radio receivers and in vhf exciters to attenuate harmonics and subharmonics of the signal frequency.

Unity Coupling If the grid-tuning capacitor of figure 48 is removed and the coupling increased to the maximum practicable value by interwinding the turns of the two coils, the circuit insofar as r.f. is concerned, acts like that of figure 46, in which one tank serves both as plate tank for the driver and grid tank for the driven stage. The interwound grid winding serves simply to isolate the d-c plate voltage of the driver from the grid of the driven stage, and to provide a return for d-c grid current. This type of coupling, illustrated in figure 49, is commonly known as *unity coupling*.

Because of the high mutual inductance, both primary and secondary are resonated by the one tuning capacitor.

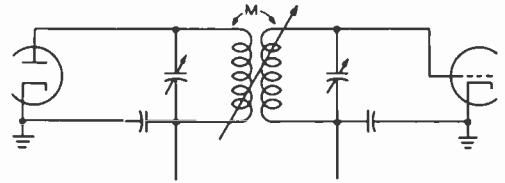

Figure 48

INDUCTIVE INTERSTAGE COUPLING

Link Coupling A modified form of inductive coupling termed *link coupling* is often used in transmitting equipment when two stages are separated by a distance comparable to a fraction of the operational wavelength. A low-impedance r-f transmission line couples the two tuned circuits together. Each end of the line is terminated in one or more turns of wire, or links, wound around the coils which are being coupled together. These links should be coupled to each tuned circuit at the point of zero r-f potential, or *nodal point*. A ground connection to one side of the link usually is used to reduce harmonic coupling, or where capacitive coupling between two circuits must be minimized. Coaxial line is commonly used to transfer energy between the two coupling links (figure 50).

11-14 Radio-Frequency Chokes

Radio-frequency chokes are connected in circuits for the purpose of attenuating the

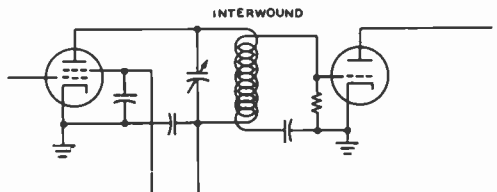

Figure 49

"UNITY" INDUCTIVE COUPLING

Due to the high value of coupling between the two coils, one tuning capacitor tunes both circuits. This arrangement often is useful in coupling from a single-ended to a push-pull stage.

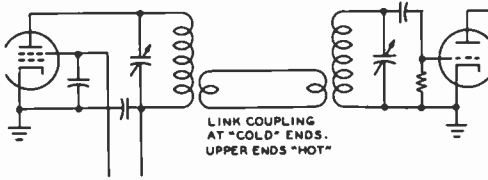

Figure 50

INTERSTAGE COUPLING BY MEANS OF A LINK

Link interstage coupling is very commonly used since the two stages may be separated by a considerable distance, since the amount of a coupling between the two stages may be easily varied, and since the capacitances of the two stages may be isolated to permit use of larger inductances in the vhf range.

passage of r-f energy while still permitting a direct current or audio-frequency current to pass. They consist of inductances wound with a large number of turns, either in the form of a solenoid, a series of solenoids, a single universal pie winding, or a series of pie windings. These inductors are designed to have as much inductance and as little distributed or shunt capacitance as possible. The unavoidable small amount of distributed capacitance resonates the inductance, and when the choke terminals are shorted,

the series-resonant frequency should fall outside the operating range of the choke. R-f chokes for operation on several bands must be designed carefully so that the impedance of the choke will be extremely high (several hundred thousand ohms) in each of the bands.

The direct current which flows through the r-f choke largely determines the size of wire to be used in the winding. The inductance of r-f chokes for the vhf range is much less than for chokes designed for broadcast and ordinary short-wave operation. A very high-inductance r-f choke has more distributed capacitance than a smaller one, with the result that it will actually offer less impedance at very high frequencies.

Another consideration, just as important as the amount of d.c. the winding will carry, is the r-f voltage which may be placed across the choke without its breaking down. This is a function of insulation, turn spacing, frequency, number and spacing of pies, and other factors.

Some chokes which are designed to have a high impedance over a very wide range of frequency are, in effect, really two chokes: a uhf choke in series with a high-frequency choke. A choke of this type is polarized; that is, it is important that the correct end of the combination choke be connected to the "hot" side of the circuit.

Various r-f choke designs for h-f and vhf operation are shown in Table 2. Series resonance is checked by shorting the choke terminals with a wire and finding the lowest self-resonant frequency with a grid-dip oscillator. Do not coat the chokes with liquid insulative material as it tends to increase the distributed capacity and lower the self-resonant frequency.

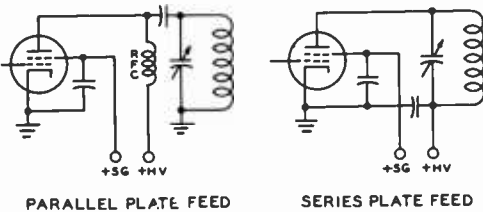

Figure 51

ILLUSTRATING PARALLEL AND SERIES PLATE FEED

Parallel plate feed is desirable from a safety standpoint since the tank circuit is at ground potential with respect to d.c. However, a high-impedance r-f choke is required, and the r-f choke must be able to withstand the peak r-f voltage output of the tube. Series plate feed eliminates the requirement for a high-performance r-f choke, but requires the use of a relatively large value of bypass capacitance at the bottom end of the tank circuit, as contrasted to the moderate value of coupling capacitance which may be used at the top of the tank circuit for parallel plate feed.

11-15 Parallel and Push-Pull Tube Circuits

The comparative r-f power output from parallel or push-pull operated amplifiers is the same if proper impedance matching is accomplished, if sufficient grid excitation is available in both cases, and if the frequency of measurement is considerably lower than the frequency limit of the tubes.

Table 2. H-F Radio-Frequency Chokes for Power Amplifiers

4000-Watt Peak Rating	
7-30 MHz:	90 turns #18 Formex, close-wound, about $4\frac{1}{8}$ " long on $\frac{3}{4}$ " diam. \times $6\frac{1}{2}$ " long teflon form. Series resonant at 43 MHz ($32\mu\text{H}$).
14-54 MHz:	43 turns #16 Formex space-wound wire diameter, about $4\frac{1}{8}$ " long on $\frac{3}{4}$ " diam. \times $6\frac{1}{2}$ " long Teflon form. Series resonant at 96 MHz ($15\mu\text{H}$) It is suggested that the form be grooved on a lathe for ease in winding.
2000-Watt PEP Rating	
3.5-30 MHz:	110 turns #26e., space-wound wire diameter, about 4" long on 1" diam. \times 6" long ceramic form. Series resonant at 25 MHz. ($78\mu\text{H}$).
21-54 MHz:	48 turns #26e., space-wound wire diameter, about $1\frac{1}{2}$ " long on $\frac{1}{2}$ " \times 3" long ceramic form. Or Air-Dux 432-T (B & W 3004) on wood form. Series resonant near 130 MHz. ($75\mu\text{H}$).

Parallel Operation Operating tubes in parallel has some advantages in transmitters designed for operation below 30 MHz, particularly when tetrode or pentode tubes are to be used. Only one neutralizing capacitor is required for parallel operation of triode tubes, as against two for push-pull. Above about 30 MHz, depending on the tube type, parallel-tube operation is not ordinarily recommended with triode tubes. However, parallel operation of grounded-grid stages and stages using low-C beam tetrodes often will give excellent results well into the vhf range.

Push-Pull Operation The push-pull connection provides a well-balanced circuit insofar as miscellaneous capacitances are concerned; in addition, the circuit can be neutralized more completely, especially in high-frequency amplifiers. The LC ratio in a push-pull amplifier can be made higher than in a plate-neutralized parallel-tube operated amplifier. Push-pull amplifiers, when perfectly balanced, have less second-harmonic output than parallel- or single-tube amplifiers, but in practice undesired capacitive coupling and circuit unbalance more or less offset the theoretical harmonic-reducing advantages of push-pull r-f circuits.

11-16 Cooling Transmitting Tubes

Adequate cooling of the tube envelope and seals is one of the factors leading to

long tube life. Deteriorating effects increase directly with the temperature of the tube envelope and seals. Even if no cooling air is specified by the technical data sheet for a particular tube, ample free space for circulation of air about the tube is required, or else air must be forced past the tube.

As the frequency of operation of the tube is extended into the vhf region, additional cooling is usually required because of the larger r-f losses inherent in the tube structure.

Temperature-sensitive paint or crayons may be used to monitor the temperature of a tube under operating conditions. If the paint is applied to the tube envelope in a *very* thin coat, it will melt and virtually disappear at its critical temperature. After subsequent cooling, it will have a crystalline appearance indicating that the surface with which it is in contact has exceeded the critical temperature. Temperature-sensitive tapes and decals are also available to measure envelope temperature of transmitting tubes.

11-17 High-Power R-F Chokes

The design of r-f chokes is discussed in Chapter 17, Section 3. By observing the series-resonant frequency of the choke, a homemade, high-power r-f choke may be made very inexpensively. Representative designs are shown in Table 2. The first choke covers the 7.0- to 30-MHz frequency region

and the first series resonance occurs at 43 MHz. The choke is rated for a maximum voltage of 5 kV and a maximum plate current of 2 amperes d.c. The second choke covers the 3.5- to 30-MHz region, with the exception of the series-resonance fre-

quency of 25 MHz. The choke is rated for 3 kV at 1 ampere d.c. The third choke is designed for the 21- to 54-MHz region with a series-resonance near 130 MHz. It has the same voltage and current rating as the second choke.

R-F Feedback

Comparatively high gain is required in single-sideband equipment because the signal is usually generated at levels of one watt or less. To get from this level to a kilowatt requires about 30 db of gain. High gain tetrodes may be used to obtain this increase with a minimum number of stages and circuits. Each stage contributes some distortion; therefore, it is good practice to keep the number of stages to a minimum. It is generally considered good practice to operate the low-level amplifiers below their maximum power capability in order to confine most of the distortion to the last two amplifier stages. *R-f feedback* can then be utilized to reduce the distortion in the last two stages. This type of feedback is no different from the common audio feedback used in high-fidelity sound systems. A sample of the output waveform is applied to the amplifier input to correct the distortion developed in the amplifier. The same advantages can be obtained at radio frequencies that are obtained at audio frequencies when feedback is used.

12-1 R-F Feedback Circuits

R-f feedback circuits have been developed by the *Collins Radio Co.* for use with linear amplifiers. Tests with large receiving and small transmitting tubes showed that amplifiers using these tubes without feedback developed signal-to-distortion ratios no better than 30 db or so. Tests were run employing cathode-follower circuits, such as shown in figure 1A. Lower distortion was achieved, but at the cost of low gain per stage. Since the voltage gain through the tube is less than unity, all gain has to be achieved by voltage step-up in the tank circuits. This gain is limited by the dissipation of the tank coils, since the circuit capacitance across the coils in a typical transmitter is quite high. In addition, the tuning of such a stage is sharp because of the high-*Q* circuits.

The cathode-follower performance of the tube can be retained by moving the *r-f* ground

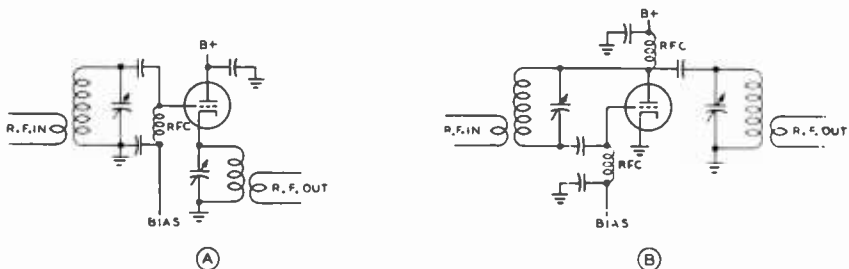

Figure 1
SIMILAR CATHODE FOLLOWER CIRCUITS HAVING DIFFERENT R-F GROUND POINTS

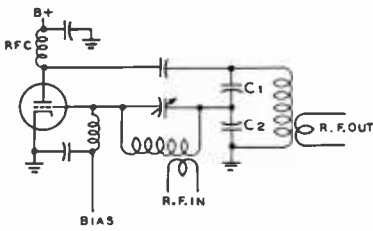

Figure 2
SINGLE STAGE AMPLIFIER WITH R-F FEEDBACK CIRCUIT

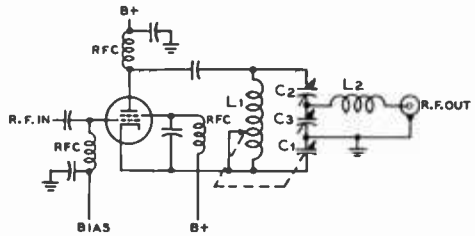

Figure 4
R-F AMPLIFIER WITH FEEDBACK AND IMPEDANCE MATCHING OUTPUT NETWORK

Tuning and loading are accomplished by C_2 and C_3 . C_1 and L_1 are tuned in unison to establish the correct degree of feedback.

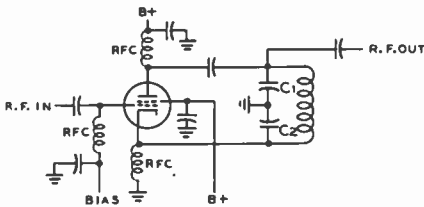

Figure 3
SINGLE STAGE FEEDBACK AMPLIFIER WITH GROUND RETURN POINT MODIFIED FOR UNBALANCED INPUT AND OUTPUT CONNECTIONS

Inductive coupling is required for this circuit, as shown in the illustration.

The circuit of figure 3 eliminates the need for inductive coupling by moving the r-f ground to the point common to both tank circuits. The advantages of direct coupling between stages far outweigh the disadvantages of having the r-f feedback voltage appear on the cathode of the amplifier tube.

In order to match the amplifier to a load, the circuit of figure 4 may be used. The ratio of X_{L1} to X_{C1} determines the degree of feedback, so it is necessary to tune them in unison when the frequency of operation is changed. Tuning and loading functions are accomplished by varying C_2 and C_3 . L_2 may also be varied to adjust the loading.

Feedback Around a Two-Stage Amplifier

The maximum phase shift obtainable over two simple tuned circuits does not exceed 180 degrees, and feedback around a two-stage amplifier is possible.

The basic circuit of a two stage feedback amplifier is shown in figure 5. This circuit is a conventional two-stage retrode amplifier except that r.f. is fed back from the plate circuit of the PA tube to the cathode of the driver tube. This will reduce the distortion

point of the circuit from the plate to the cathode as shown in figure 1B. Both ends of the input circuit are at high r-f potential so inductive coupling to this type of amplifier is necessary.

Inspection of figure 1B shows that by moving the top end of the input tank down on a voltage-divider tap across the plate tank circuit, the feedback can be reduced from 100%, as in the case of the cathode-follower circuit, down to any desired value. A typical feedback circuit is illustrated in figure 2. This circuit is more practical than those of figure 1, since the losses in the input tank are greatly reduced. A feedback level of 12 db may be achieved as a good compromise between distortion and stage gain. The voltage developed across C_2 will be three times the grid-cathode voltage.

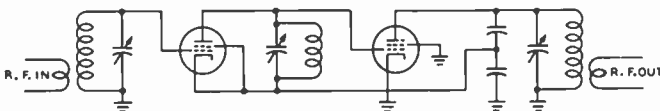

Figure 5
BASIC CIRCUIT OF TWO-STAGE AMPLIFIER WITH R-F FEEDBACK

Feedback voltage is obtained from a voltage divider across the output circuit and applied directly to the cathode of the first tube. The input tank circuit is thus outside the feedback loop.

of both tubes as effectively as using individual feedback loops around each stage, yet will allow a higher level of over-all gain. With only two tuned circuits in the feedback loop, it is possible to use 12 to 15 db of feedback and still leave a wide margin for stability. It is possible to reduce the distortion by nearly as many db as are used in feedback. This circuit has two advantages that are lacking in the single-stage feedback amplifier. First, the filament of the output stage can now be operated at r-f ground potential. Second, any conventional pi output network may be used.

R-f feedback will correct several types of distortion. It will help correct distortion caused by poor power supply regulation, too low grid bias, and limiting on peaks when the plate voltage swing becomes too high.

Neutralization and R-F Feedback The purpose of neutralization of an r-f amplifier stage is to balance out effects of the grid-plate capacitance coupling in the amplifier. In a conventional amplifier using a tetrode tube, the effective input capacity is given by:

Input capacitance $= C_{in} + C_{gp} (1 + A \cos \theta)$
where,

C_{in} equals tube input capacitance,

C_{gp} equals grid-plate capacitance,

A equals grid-to-plate voltage amplification,

θ equals angle of load.

In a typical unneutralized tetrode amplifier having a stage gain of 33, the input capacitance of the tube with the plate circuit in resonance is increased by 8 pf due to the unneutralized grid-plate capacitance. This is unimportant in amplifiers where the gain (A) remains constant but if the tube gain varies, serious detuning and r-f phase shift may result. A grid or screen modulated r-f amplifier is an example of the case where the stage gain varies from a maximum down to zero. The gain of a tetrode r-f amplifier operating below plate current saturation varies with loading so that if it drives a following stage into grid current the loading increases and the gain falls off.

The input of the grid circuit is also affected by the grid-plate capacitance, as shown in this equation:

$$\text{Input resistance} = \frac{1}{2\pi f \times C_{gp} (A \sin \theta)}$$

This resistance is in shunt with the grid current loading, grid tank circuit losses, and driving source impedance. When the plate cir-

cuit is inductive there is energy transferred from the plate to the grid circuit (positive feedback) which will introduce negative resistance in the grid circuit. When this shunt negative resistance across the grid circuit is lower than the equivalent positive resistance of the grid loading, circuit losses, and driving source impedance, the amplifier will oscillate.

When the plate circuit is in resonance (phase angle equal to zero) the input resistance due to the grid-plate capacitance becomes infinite. As the plate circuit is tuned to the capacitive side of resonance, the input resistance becomes positive and power is actually transferred from the grid to the plate circuit. This is the reason that the grid current in an unneutralized tetrode r-f amplifier varies from a low value with the plate circuit tuned on the low-frequency side of resonance to a high value on the high-frequency side of resonance. The grid current is proportional to the r-f voltage on the grid which is varying under these conditions. In a tetrode class-AB₁ amplifier, the effect of grid-plate feedback can be observed by placing a r-f voltmeter across the grid circuit and observing the voltage change as the plate circuit is tuned through resonance.

If the amplifier is over-neutralized, the effects reverse so that with the plate circuit tuned to the low-frequency side of resonance, the grid voltage is high, and on the high-frequency side of resonance, it is low.

Amplifier Neutralization Check A useful "rule of thumb" method of checking neutralization of an amplifier stage (assuming that it is nearly correct to start with) is to tune both grid and plate circuits to resonance. Then, observing the r-f grid current, tune the plate circuit to the high-frequency side of resonance.

If the grid current rises, more neutralization capacitance is required. Conversely, if the grid current decreases, less capacitance is needed. This indication is very sensitive in a neutralized triode amplifier, and correct neutralization exists when the grid current peaks at the point of plate current dip. In tetrode power amplifiers this indication is less pronounced. Sometimes in a supposedly neutralized tetrode amplifier, there is practically no change in grid voltage as the plate circuit is tuned through resonance, and in some amplifiers it is unchanged on one side of resonance and drops slightly on the other side. Another observation sometimes made is a small dip in the center of a broad peak of grid current. These various effects are probably caused by

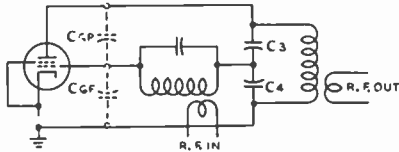

Figure 6
SINGLE STAGE R-F AMPLIFIER
WITH FEEDBACK RATIO OF
 C_3/C_4 TO C_{gp}/C_{gf} DETERMINES
STAGE NEUTRALIZATION

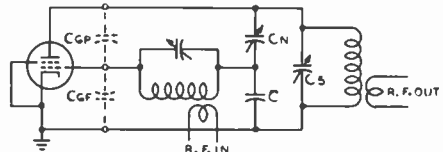

Figure 7
NEUTRALIZED AMPLIFIER AND
INHERENT FEEDBACK CIRCUIT
Neutralization is achieved by varying
the capacity of C_N .

coupling from the plate to the grid circuit through other paths which are not balanced out by the particular neutralizing circuit used.

Feedback and Neutralization of a One-Stage R-F Amplifier

Figure 6 shows an r-f amplifier with negative feedback. The voltage developed across C_4 due to the divider action of C_3 and C_1

is introduced in series with the voltage developed across the grid tank circuit and is in phase-opposition to it. The feedback can be made any value from zero to 100% by properly choosing the values of C_3 and C_1 .

For reasons stated previously, it is necessary to neutralize this amplifier, and the relationship for neutralization is:

$$\frac{C_3}{C_4} = \frac{C_{gp}}{C_{gf}}$$

It is often necessary to add capacitance from plate to grid to satisfy this relationship

Figure 7 is identical to figure 6 except that it is redrawn to show the feedback inherent in this neutralization circuit more clearly. C_N and C replace C_3 and C_1 , and the main plate tank tuning capacitance is C_5 . The circuit of figure 7 presents a problem in coupling to the grid circuit. Inductive coupling is ideal, but the extra tank circuits complicate the tuning of a transmitter which uses several cascaded amplifiers with feedback around each one. The grid could be coupled to a high source impedance such as a tetrode plate, but the driver then cannot use feedback because this would cause the source impedance to be low. A possible solution is to move the circuit ground point from the cathode to the bottom end of the grid tank circuit. The feedback voltage then appears between the cathode and ground (figure 8). The input can be capacitively coupled, and the plate of the amplifier can be capacitively coupled to the next stage. Also, cathode type transmitting tubes are available that allow the heater to remain at ground po-

tential when r.f. is impressed upon the cathode. The output voltage available with capacity coupling, of course, is less than the plate-cathode r-f voltage developed by the amount of feedback voltage across C_1 .

12-2 Feedback and Neutralization of a Two-Stage R-F Amplifier

Feedback around two r-f stages has the advantage that more of the tube gain can be realized and nearly as much distortion reduction can be obtained using 12 db around two stages as is realized using 12 db around each of two stages separately. Figure 9 shows a basic circuit of a two-stage feedback amplifier. Inductive output coupling is used, although a pi-network configuration will also work well. The small feedback voltage required is obtained from the voltage divider (C_1 - C_2) and is applied to the cathode of the driver tube. C_1 is only a few pf, so this feedback voltage divider may be left fixed for a wide frequency range. If the combined tube gain is 160, and 12 db of feedback is desired, the ratio of C_2 to C_1 is about 40 to 1. This ratio in practice may be 100 pf to 2.5 pf, for example.

A complication is introduced into this simplified circuit by the cathode-grid capacitance

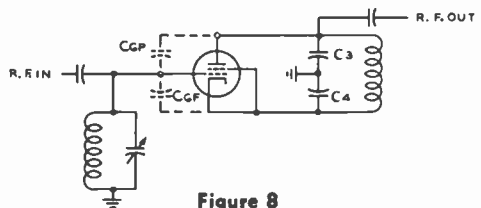

Figure 8
UNBALANCED INPUT AND OUTPUT
CIRCUITS FOR SINGLE-STAGE
R-F AMPLIFIER WITH FEEDBACK

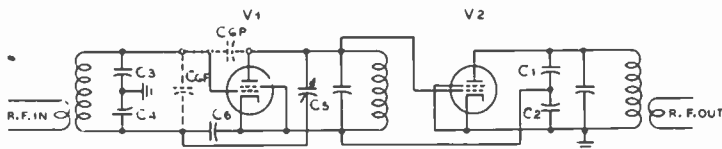

Figure 9
TWO-STAGE AMPLIFIER WITH FEEDBACK

Included is a capacitor (C₂) for neutralizing the cathode-grid capacity of the first tube. V₁ is neutralized by capacitor C₆, and V₂ is neutralized by the correct ratio of C₁/C₂.

of the first tube which causes an undesired coupling to the input grid circuit. It is necessary to neutralize out this capacitance coupling, as illustrated in figure 9. The relationship for neutralization is:

$$\frac{C_3}{C_4} = \frac{C_{gf}}{C_6}$$

The input circuit may be made unbalanced by making C₁ five times the capacity of C₂. This will tend to reduce the voltage across the coil and to minimize the power dissipated by the coil. For proper balance in this case, C₆ must be five times the grid-filament capacitance of the tube.

Except for tubes having extremely small grid-plate capacitance, it is still necessary to properly neutralize both tubes. If the ratio of C₁ to C₂ is chosen to be equal to the ratio of the grid-plate capacitance to the grid-filament capacitance in the second tube (V₂), this tube will be neutralized. Tubes such as a 4X-150A have very low grid-plate capacitance and probably will not need to be neutralized when used in the first (V₁) stage. If neutralization is necessary, capacitor C₅ is added for this purpose and the proper value is given by the following relationship:

$$\frac{C_{gp}}{C_5} = \frac{C_{rf}}{C_6} = \frac{C_3}{C_4}$$

If neither tube requires neutralization, the bottom end of the interstage tank circuit may be returned to r-f ground. The screen and suppressor of the first tube should then be grounded to keep the tank output capacitance directly across this interstage circuit and to avoid common coupling between the feedback on the cathode and the interstage circuit. A slight amount of degeneration occurs in the first stage since the tube also acts as a grounded grid amplifier with the screen as the grounded grid. The μ of the screen is much lower than that of the control grid so that this effect may be unnoticed and would only require slightly

more feedback from the output stage to overcome.

Tests For Neutralization Neutralizing the circuit of figure 9 balances out coupling between the input tank circuit and the output tank circuit, but it does not remove all coupling from the plate circuit to the grid-cathode tube input. This latter coupling is degenerative, so applying a signal to the plate circuit will cause a signal to appear between grid and cathode, even though the stage is neutralized. A bench test for neutralization is to apply a signal to the plate of the tube and detect the presence of a signal in the grid coil by inductive coupling to it. No signal will be present when the stage is neutralized. Of course, a signal could be inductively coupled to the input and neutralization accomplished by adjusting one branch of the neutralizing circuit bridge (C₅ for example) for minimum signal on the plate circuit.

Neutralizing the cathode-grid capacitance of the first stage of figure 9 may be accomplished by applying a signal to the cathode of the tube and adjusting the bridge balance for minimum signal on a detector inductively coupled to the input coil.

Tuning a Two-Stage Feedback Amplifier Tuning the two-stage feedback amplifier of figure 9 is accomplished in an unconventional way because the output circuit cannot be tuned for maximum output signal. This is because the output circuit must be tuned so the feedback voltage applied to the cathode is in-phase with the input signal applied to the first grid. When the feedback voltage is not in-phase, the resultant grid-cathode voltage increases as shown in figure 10. When the output circuit is properly tuned, the resultant grid-cathode voltage on the first tube will be at a minimum, and the voltage on the interstage tuned circuit will also be at a minimum.

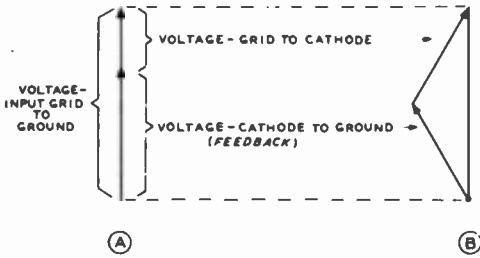

Figure 10
VECTOR RELATIONSHIP OF
FEEDBACK VOLTAGE
 A = Output Circuit Properly Tuned
 B = Output Circuit Mis-Tuned

The two-stage amplifier may be tuned by placing a r-f voltmeter across the interstage tank circuit ("hot" side to ground) and tuning the input and interstage circuits for maximum meter reading, and tuning the output circuit for minimum meter reading. If the second tube is driven into the grid current region, the grid current meter may be used in place of the r-f voltmeter. On high powered stages where operation is well into the class-AB region, the plate current dip of the output tube indicates correct output circuit tuning, as in the usual amplifier.

Parasitic Oscillations in the Feedback Amplifier

Quite often low frequency parasitics may be found in

the interstage circuit of the two-stage feedback amplifier. Oscillation occurs in the first stage due to low frequency feedback in the cathode circuit. R-f chokes, coupling capacitors, and bypass capacitors provide the low frequency tank circuits. When the feedback and second stage neutralizing circuits are combined, it is necessary to use the configuration of figure 11. This circuit has the advantage that only one capacitor (C_3) is required from the plate of the output tube, thus keeping the added capacitance across the output tank at a minimum.

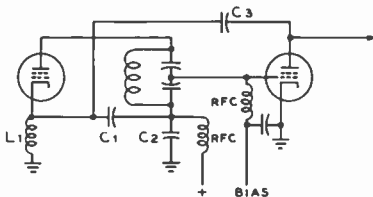

Figure 11
INTERSTAGE CIRCUIT COMBINING
NEUTRALIZATION AND
FEEDBACK NETWORKS

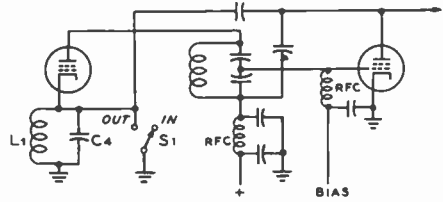

Figure 12
INTERSTAGE CIRCUIT WITH
SEPARATE NEUTRALIZING
AND FEEDBACK CIRCUITS

It is convenient, however, to separate these circuits so neutralization and feedback can be adjusted independently. Also, it may be desirable to be able to switch the feedback out of the circuit. For these reasons, the circuit shown in figure 12 is often used. Switch S_1 removes the feedback loop when it is closed.

A slight tendency for low-frequency parasitic oscillations still exists with this circuit. L_1 should have as little inductance as possible without upsetting the feedback. If the value of L_1 is too low, it cancels out part of the reactance of feedback capacitor C_1 and causes the feedback to increase at low values of radio frequency. In some cases, a swamping resistor may be necessary across L_1 . The value of this resistor should be high compared to the reactance of C_1 to avoid phase-shift of the r-f feedback.

12-3 Neutralization Procedure in Feedback-Type Amplifiers

Experience with feedback amplifiers has brought out several different methods of neutralizing. An important observation is that when all three neutralizing adjustments are correctly made the peaks and dips of various tuning meters all coincide at the point of circuit resonance. For example, the coincident indications when the various tank circuits are tuned through resonance with feedback operating are:

- A—When the PA plate circuit is tuned through resonance:
- 1—PA plate current dip
- 2—Power output peak
- 3—PA r-f grid voltage dip
- 4—PA grid current dip

(Note: The PA grid current peaks when feedback circuit is disabled and the tube is heavily driven)

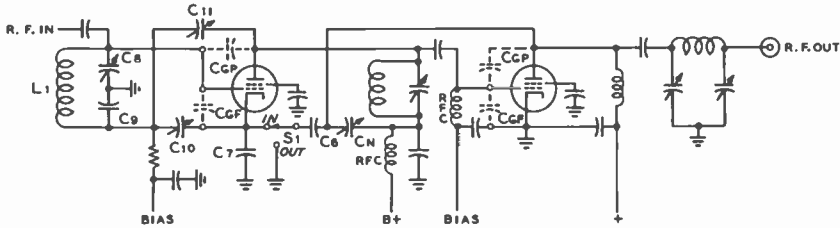

Figure 13

TWO-STAGE AMPLIFIER WITH FEEDBACK CIRCUIT

B—When the PA grid circuit is tuned through resonance:

- 1—Driver plate current dip
- 2—PA r-f grid voltage peak
- 3—PA grid current peak
- 4—PA power output peak

C—When the driver grid circuit is tuned through resonance:

- 1—Driver r-f grid voltage peak
- 2—Driver plate current peak
- 3—PA r-f grid current peak
- 4—PA plate current peak
- 5—PA power output peak

Four meters may be employed to measure the most important of these parameters. The meters should be arranged so that the following pairs of readings are displayed on meters located close together for ease of observation of coincident peaks and dips:

- 1—PA plate current and power output
- 2—PA r-f grid current and PA plate current
- 3—PA r-f grid voltage and power output
- 4—Driver plate current and PA r-f grid voltage

The third pair listed above may not be necessary if the PA plate current dip is pronounced. When this instrumentation is provided, the neutralizing procedure is as follows:

- 1—Remove the r-f feedback

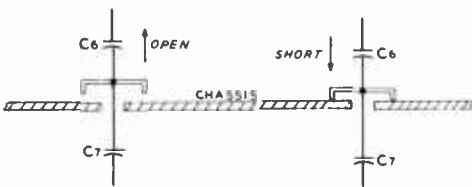

Figure 14
FEEDBACK SHORTING DEVICE

- 2—Neutralize the grid-plate capacitance of the driver stage
- 3—Neutralize the grid-plate capacitance of the power amplifier (PA) stage
- 4—Apply r-f feedback
- 5—Neutralize driver grid-cathode capacitance

These steps will be explained in more detail in the following paragraphs:

Step 1. The removal of r-f feedback through the feedback circuit must be complete. The switch (S₁) shown in the feedback circuit (figure 13) is one satisfactory method. Since C₁₁ is effectively across the PA plate tank circuit it is desirable to keep it across the circuit when feedback is removed to avoid appreciable detuning of the plate tank circuit. Another method that can be used if properly done is to ground the junction of C₆ and C₇. Grounding this common point through a switch or relay is not good enough because of common coupling through the length of the grounding lead. The grounding method shown in figure 14 is satisfactory.

Step 2. Plate power and excitation are applied. The driver grid tank is resonated by tuning for a peak in driver r-f grid voltage or driver plate current. The power amplifier grid tank circuit is then resonated and adjusted for a dip in driver plate current. Driver neutralization is now adjusted until the PA r-f grid voltage (or PA grid current) peaks at exactly the point of driver plate current dip. A handy rule for adjusting grid-plate neutralization of a tube without feedback: with all circuits in resonance, detune the plate circuit to the high frequency side of resonance: If grid current to next stage (or power output of the stage under test) increases, more neutralizing capacitance is required and vice versa.

If the driver tube operates class A so that a plate current dip cannot be observed, a dif-

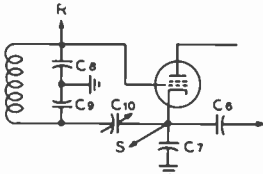

Figure 15
FEEDBACK NEUTRALIZING
CIRCUIT USING
AUXILIARY RECEIVER

ferent neutralizing procedure is necessary. This will be discussed in a subsequent section.

Step 3. This is the same as step 2 except it is applied to the power amplifier stage. Adjust the neutralization of this stage for a peak in power output at the plate current dip.

Step 4. Reverse step 1 and apply the r-f feedback.

Step 5. Apply plate power and an exciting signal to drive the amplifier to nearly full output. Adjust the feedback neutralization for a peak in amplifier power output at the exact point of minimum amplifier plate current. Decrease the feedback neutralization capacitance if the power output rises when the tank circuit is tuned to the high frequency side of resonance.

The above sequence applies when the neutralizing adjustments are approximately correct to start with. If they are far off, some "cut-and-try" adjustment may be necessary. Also, the driver stage may break into oscillation if the feedback neutralizing capacitance is not near the correct setting.

It is assumed that a single-tone test signal is used for amplifier excitation during the above steps, and that all tank circuits are at resonance except the one being detuned to make the observation. There is some interaction between the driver neutralization and the feedback neutralization so if an appreciable change is made in any adjustment the others should be rechecked. It is important that the grid-plate neutralization be accomplished first when using the above procedure, otherwise the feedback neutralization will be off a little, since it partially compensates for that error.

Neutralization Techniques The method of neutralization employing a sensitive r-f detector inductively coupled to a tank coil is difficult to apply in some cases because of mechanical construction of the equipment, or because of undesired coupling. Another method for observing neutralization can be used, which appears to be more accurate in actual practice. A sensitive r-f detector such as a receiver is loosely coupled to the grid of the stage being neutralized, as shown in figure 15. The coupling capacitance is of the order of one or two pf. It must be small enough to avoid upsetting the neutralization when it is removed because the total grid-ground capacitance is one leg of the neutralizing bridge. A signal generator is connected at point S and the receiver at point R. If C_{10} is not properly adjusted the S-meter on the receiver will either kick up or down as the grid tank circuit is tuned through resonance. C_{10} may be adjusted for minimum deflection of the S-meter as the grid circuit is tuned through resonance.

The grid-plate capacitance of the tube is then neutralized by connecting the signal generator to the plate of the tube and adjusting C_{11} of figure 13 for minimum deflection again as the grid tank is tuned through resonance. The power amplifier stage is neutralized in the same manner by connecting a receiver loosely to the grid circuit, and attaching a signal generator to the plate of the tube. The r-f signal can be fed into the amplifier output terminal if desired.

Some precautions are necessary when using this neutralization method. First, some driver tubes (the 6CL6, for example) have appreciably more effective input capacitance when in operation and conducting plate current than when in standby condition. This increase in input capacitance may be as great as three or four pf, and since this is part of the neutralizing bridge circuit it must be taken into consideration. The result of this change in input capacitance is that the neutralizing adjustment of such tubes must be made when they are conducting normal plate current. Stray coupling must be avoided, and it may prove helpful to remove filament power from the preceding stage or disable its input circuit in some manner.

It should be noted that in each of the above adjustments that minimum reaction on the grid is desired, not minimum voltage. Some residual voltage is inherent on the grid when this neutralizing circuit is used.

Amplitude Modulation and Audio Processing

If the output of a c-w transmitter is varied in amplitude at an audio frequency rate instead of interrupted in accordance with code characters, a tone will be heard on a receiver tuned to the signal. If the audio signal consists of a band of audio frequencies comprising voice or music intelligence, then the voice or music which is superimposed on the radio-frequency carrier will be heard on the receiver.

When voice, music, video, or other intelligence is superimposed on a radio frequency carrier by means of a corresponding variation in the *amplitude* of the radio frequency output of a transmitter, *amplitude modulation* is the result. Telegraph keying of a c-w transmitter is the simplest form of amplitude modulation, while video modulation in a television transmitter represents a highly complex form.

Low-level amplitude modulation (a-m) is commonly used to generate an SSB signal, the a-m wave being passed through a highly selective filter to remove the carrier and unwanted sideband. Systems for modulating the amplitude of a carrier envelope in accordance with voice, music, or similar types of complicated audio waveforms are many and varied, and will be discussed later in this chapter.

13-1 Sidebands

Modulation is essentially a form of *mixing*, or *combining*, already covered in a previous

chapter. To transmit voice at radio frequencies by means of amplitude modulation, the voice frequencies are mixed with a radio-frequency carrier so that the voice frequencies are converted to radio-frequency *sidebands*. Though it may be difficult to visualize, *the amplitude of the radio-frequency carrier does not vary during conventional amplitude modulation.*

Even though the amplitude of radio-frequency voltage representing the composite signal (resultant of the carrier and sidebands, called the *envelope*) will vary from zero to twice the unmodulated signal value during full modulation, the amplitude of the *carrier* component does not vary. Also, as long as the amplitude of the modulating voltage does not vary, the amplitude of the sidebands will remain constant. For this to be apparent, however, it is necessary to measure the amplitude of each component with a highly selective filter. Otherwise, the measured power or voltage will be a *resultant* of two or more of the components, and the amplitude of the resultant will vary at the modulation rate.

If a carrier frequency of 5000 kHz is modulated by a pure tone of 1000 Hz, or 1 kHz, two sidebands are formed: one at 5001 kHz (the sum frequency) and one at 4999 kHz (the difference frequency). The frequency of each sideband is independent of the amplitude of the modulating tone, or *modulation percentage*; the frequency of each sideband is determined only by the frequency of the modulating tone. This assumes,

of course, that the transmitter is not modulated in excess of its linear capability.

When the modulating signal consists of multiple frequencies, as is the case with voice or music modulation, two sidebands will be formed by each modulating frequency (one on each side of the carrier), and the radiated signal will consist of a *band* of frequencies. The *bandwidth*, or *channel*, taken up in the frequency spectrum by a conventional double-sideband amplitude-modulated signal, is equal to twice the highest modulating frequency. For example, if the highest modulating frequency is 5000 Hz, then the signal (assuming modulation of complex and varying waveform) will occupy a band extending from 5000 Hz below the carrier to 5000 Hz above the carrier.

Frequencies up to at least 2500 Hz, and preferably 3500 Hz, are necessary for good speech intelligibility. If a filter is incorporated in the audio system to cut out all frequencies above approximately 3000 Hz, the bandwidth of a radiotelephone signal can be limited to 6 kHz without a significant loss in intelligibility. However, if harmonic distortion is introduced subsequent to the filter, as would happen in the case of an overloaded modulator or overmodulation of the carrier, new frequencies will be generated and the signal will occupy a band wider than 6 kHz.

13-2 Mechanics of Modulation

A c-w or unmodulated r-f carrier wave is represented in figure 1A. An audio-frequency sine wave is represented by the curve of figure 1B. When the two are combined or "mixed," the carrier is said to be amplitude modulated, and a resultant similar to 1C or 1D is obtained. It should be noted that under modulation, each half cycle of r-f voltage differs slightly from the preceding one and the following one; therefore at no time during modulation is the r-f waveform a pure sine wave. This is simply another way of saying that during modulation, the transmitted r-f energy no longer is confined to a single radio frequency.

It will be noted that the *average* amplitude of the peak r-f voltage, or modulation envelope,

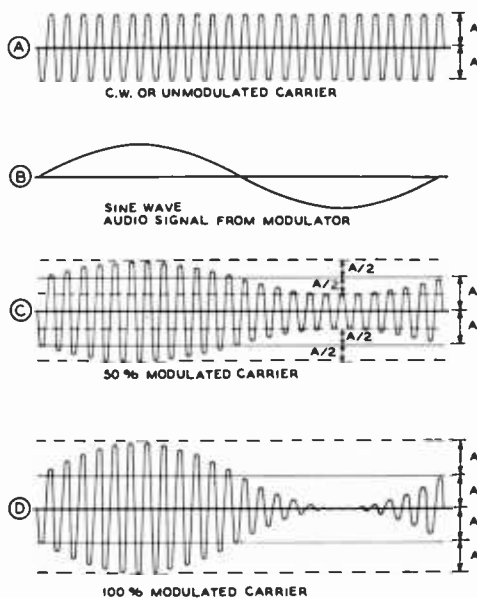

Figure 1

AMPLITUDE-MODULATED WAVE

Top drawing A represents an unmodulated carrier wave; B shows the audio output of the modulator. Drawing C shows the audio signal impressed on the carrier wave to the extent of 50 percent modulation; D shows the carrier with 100 percent amplitude modulation.

lope, is the same with or without modulation. This simply means that the modulation is symmetrical (assuming a symmetrical modulating wave) and that for distortionless modulation the upward modulation is limited to a value of twice the unmodulated carrier wave amplitude because the amplitude cannot go below zero on downward portions of the modulation cycle. Figure 1D illustrates the maximum obtainable distortionless modulation with a sine modulating wave, the r-f voltage at the peak of the r-f cycle varying from zero to twice the unmodulated value, and the r-f power varying from zero to four times the unmodulated value (the power varies as the square of the voltage).

While the average r-f *voltage* of the modulated wave over a modulation cycle is the same as for the unmodulated carrier, the average *power* increases with modulation. If the radio-frequency power is integrated over the audio cycle, it will be found with 100

percent sine-wave modulation the average r-f power has increased 50 percent. This additional power is represented by the sidebands, because, as previously mentioned, the carrier power does not vary under modulation. Thus, when a 100-watt carrier is modulated 100 percent by a sine wave, the total r-f power is 150 watts—100 watts in the carrier and 25 watts in each of the two sidebands.

Modulation Percentage So long as the *relative proportion* of the various sidebands making up voice modulation is maintained, the signal may be received and detected without distortion. However, the higher the average amplitude of the sidebands, the greater the audio signal produced at the receiver. For this reason it is desirable to increase the *modulation percentage*, or degree of modulation, to the point where maximum peaks just hit 100 percent. If the modulation percentage is increased so that the peaks exceed this value, distortion is introduced, and if carried very far, bad interference to signals on nearby channels will result.

Modulation Measurement The amount by which a carrier is being modulated may be expressed either as a modulation factor, varying from zero to 1.0 at maximum modulation, or as a percentage. The percentage of modulation is equal to 100 times the modulation factor. Figure 2A shows a carrier wave modulated by a sine-wave audio tone. A picture such as this might be seen on the screen of a cathode-ray oscilloscope with sawtooth sweep on the horizontal plates and the modulated carrier impressed on the vertical plates. The same carrier without modulation would appear on the oscilloscope screen as figure 2B.

The percentage of modulation of the positive peaks and the percentage of modulation of the negative peaks can be determined separately from two oscilloscope pictures such as shown.

The modulation factor of the positive peaks may be determined by the formula:

$$M = \frac{E_{\max} - E_{\text{car}}}{E_{\text{car}}}$$

The factor for negative peaks may be determined from the formula:

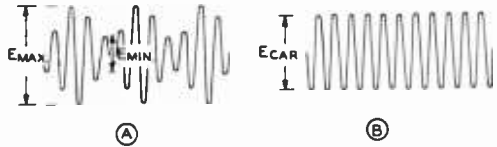

Figure 2

GRAPHICAL DETERMINATION OF MODULATION PERCENTAGE

The procedure for determining modulation percentage from the peak voltage points indicated is discussed in the text.

$$M = \frac{E_{\text{car}} - E_{\min}}{E_{\text{car}}}$$

In the above two formulas E_{\max} is the maximum carrier amplitude with modulation and E_{\min} is the minimum amplitude; E_{car} is the steady-state amplitude of the carrier without modulation. Since the deflection of the spot on a cathode-ray tube is linear with respect to voltage, the relative voltages of these various amplitudes may be determined by measuring the deflections, as viewed on the screen, with a rule calibrated in inches or centimeters. The percentage of modulation of the carrier may be found by multiplying the modulation factor thus obtained by 100. The above procedure assumes that there is no *carrier shift*, or change in average carrier amplitude with modulation.

If the modulating voltage is symmetrical, such as a sine wave, and modulation is accomplished without the introduction of distortion, then the percentage modulation will be the same for both negative and positive peaks. However, the distribution and phase relationships of harmonics in voice and music waveforms are such that the percentage modulation of the negative modulation peaks may exceed the percentage modulation of the positive peaks, or vice versa. The percentage modulation when referred to without regard to polarity is an indication of the average of the negative and positive peaks.

Modulation Capability The modulation capability of a transmitter is the maximum percentage to which that transmitter may be modulated before spurious sidebands are generated in the output or

before the distortion of the modulating waveform becomes objectionable. The highest modulation capability which *any* transmitter may have on the *negative* peaks is 100 percent. The maximum permissible modulation of many transmitters is less than 100 percent, especially on positive peaks. The modulation capability of a transmitter may be limited by tubes with insufficient filament emission, by insufficient excitation or grid bias to a plate-modulated stage, too light loading of any type of amplifier carrying modulated r.f., insufficient power output capability in the modulator, or too much excitation to a grid-modulated stage or a class-B linear amplifier.

Speech Waveform Dissymmetry The manner in which the human voice is produced by the vocal cords gives

rise to a certain dissymmetry in the waveform of voice sounds when they are picked up by a good quality microphone. This is especially pronounced in the male voice, and more so on certain voice sounds than on others. The result of this dissymmetry in the waveform is that the voltage peaks on one side of the average value of the wave will be considerably greater, often two or three times as great, as the voltage excursions on the other side of the zero axis. The *average* value of voltage on both sides of the wave is, of course, the same.

As a result of this dissymmetry in the male voice waveform, there is an optimum polarity of the modulating voltage that must be observed if maximum sideband energy is to be obtained without negative peak clipping and generation of *splatter* on adjacent channels.

A conclusive illustration of the lopsidedness of a speech waveform may be obtained by observing the modulated waveform of an a-m transmitter on an oscilloscope. A portion of the carrier energy of the transmitter should be coupled by means of a link directly to the vertical plates of the 'scope, and the horizontal sweep should be a sawtooth or similar wave occurring at a rate of approximately 30 to 70 sweeps per second.

With the speech signal from the speech amplifier connected to the transmitter with one polarity it will be noticed that negative-

peak clipping—as indicated by bright "spots" in the center of the 'scope pattern whenever the carrier amplitude goes to zero—will occur at a considerably lower level of average modulation than with the speech signal being fed to the transmitter with the other polarity. When the input signal to the transmitter is polarized in such a manner that the "fingers" of the speech wave extend in the direction of positive modulation these fingers usually will be clipped in the plate circuit of the modulator at an acceptable peak modulation level.

The use of the proper polarity of the incoming speech wave in modulating a transmitter can afford an increase of approximately two to one in the amount of speech audio power which may be placed on the carrier of an amplitude-modulated transmitter for the same amount of sideband splatter.

13-3 Systems of Amplitude Modulation

There are many different systems and methods for amplitude-modulating a carrier, but most may be grouped under three general classifications: (1) *variable-efficiency* systems in which the average input to the stage remains constant with and without modulation and the variations in the efficiency of the stage in accordance with the modulating signal accomplish the modulation; (2) *constant-efficiency* systems in which the input to the stage is varied by an external source of modulating energy to accomplish the modulation; and (3) so-called *high-efficiency* systems in which circuit complexity is increased to obtain high plate-circuit efficiency in the modulated stage without the requirement of an external high-level modulator. The various systems under each classification have individual characteristics which make certain ones best suited to particular applications.

Variable-Efficiency Modulation Since the *average* input remains constant in a stage employing variable-efficiency modulation, and since the average power output of the stage increases with

modulation, the additional average power output from the stage *with* modulation must come from the plate dissipation of the tubes in the stage. Hence, for the best relation between tube cost and power output, the tubes employed should have as high a plate dissipation rating per dollar as possible.

The plate efficiency in such an amplifier is doubled when going from the unmodulated condition to the peak of the modulation cycle. Hence, the unmodulated efficiency of such an amplifier *must always be less than 45 percent*, since the maximum peak efficiency obtainable in a conventional amplifier is in the vicinity of 90 percent. Since the peak efficiency in certain types of amplifiers will be as low as 60 percent, the unmodulated efficiency in such amplifiers will be in the vicinity of 30 percent.

There are many systems of efficiency modulation, but they *all* have the general limitation discussed in the previous paragraph—so long as the carrier amplitude is to remain constant with and without modulation, the efficiency at carrier level must be not greater than one-half the peak modulation efficiency, if the stage is to be capable of 100-percent modulation.

The classic example of efficiency modulation is the class-B linear r-f amplifier, to be discussed below. The other three common forms of efficiency modulation are control-grid modulation, screen-grid modulation, and suppressor-grid modulation. In each case, including that of the class-B linear amplifier, note that the modulation, or the modulated signal, is impressed on a control electrode of the stage.

The Class-B Linear Amplifier This is the simplest practicable type amplifier for an amplitude-modulated wave or a single-sideband signal. The system requires that excitation, grid bias, and loading must be carefully controlled to preserve the linearity of the stage. Also, the grid circuit of the tube, in the usual application where grid current is drawn on peaks, presents a widely varying value of load impedance to the source of excitation. Hence it is necessary to include some sort of *swamping resistor* to reduce the effect of grid-impedance variations with modulation.

If such a swamping resistance across the grid tank is not included, or is too high in value, the positive modulation peaks of the incoming modulated signal will tend to be flattened with resultant distortion of the wave being amplified.

The class-B linear amplifier has long been used in broadcast transmitters, but recently has received much more general usage in the h-f range for SSB service since the plate efficiency with full signal will be in the vicinity of 70 percent, while with no modulation the input to the stage drops to a relatively low value.

Since a class-B linear amplifier is biased to *extended* cutoff with no excitation (the grid bias at extended cutoff will be approximately equal to the plate voltage divided by the amplification factor for a triode, and will be approximately equal to the screen voltage divided by the grid-screen μ factor for a tetrode or pentode) the plate current will essentially flow in 180-degree pulses. Due to the relatively large operating angle of plate current flow the theoretical peak plate efficiency is limited to 78.5 percent, with 65 to 70 percent representing a range of efficiency normally attainable.

The carrier power output from a class-B linear amplifier of a normal 100 percent modulated a-m signal will be about one-half the rated plate dissipation of the stage, with optimum operating conditions. The peak output from a class-B linear, which represents the maximum-signal output as a single-sideband amplifier, or peak output with a 100 percent a-m signal, will be about twice the plate dissipation of the tubes in the stage. Thus the carrier-level input power to a class-B linear should be about 1.5 times the rated plate dissipation of the stage.

The schematic circuit of a grid-driven class-B linear amplifier is the same as a conventional single-ended or push-pull stage, whether triodes or beam tetrodes are used. However, a swamping resistor, as mentioned before, must be placed across the grid tank of the stage if the operating conditions of the tube are such that appreciable grid current will be drawn on modulation peaks. Also, a *fixed* source of grid bias must be provided for the stage. A regulated grid-bias power supply or zener diode are the usual source of negative bias voltage.

Adjustment of a Class-B Linear Amplifier With grid bias adjusted to the correct value, and with provision for varying the excitation voltage to the stage and the loading of the plate circuit, a fully modulated signal is applied to the grid circuit of the stage. Then with an oscilloscope coupled to the output of the stage, excitation and loading are varied until the stage is drawing the normal plate input and the output waveshape is a good replica of the input signal. The adjustment procedure normally will require a succession of approximations, until the optimum set of adjustments is attained. Then the modulation being applied to the input signal should be removed to check the linearity. With modulation removed, in the case of a 100 percent a-m signal, the input to the stage should remain constant, and the peak output of the r-f envelope should fall to one-half the value obtained on positive modulation peaks.

Class-C Grid Modulation One effective system of efficiency modulation for communications work is class-C control-grid bias modulation. The distortion is slightly higher than for a properly operated class-B linear amplifier, but the efficiency is also higher, and the distortion can be kept within tolerable limits for communications work.

Class-C grid modulation requires high plate voltage on the modulated stage if maximum output is desired. The plate voltage is normally run about 50 percent higher than for maximum output with plate modulation.

The driving power required for operation of a grid-modulated amplifier under these conditions is somewhat more than is required for operation at lower bias and plate voltage, but the increased power output obtainable overbalances the additional excitation requirement. Actually, almost half as much excitation is required as would be needed if the same stage were to be operated as a class-C plate-modulated amplifier. A resistor across the grid tank of the stage serves as *swamping* to stabilize the r-f driving voltage. At least 50 percent of the output of the driving stage should be dissipated in this swamping resistor under carrier conditions.

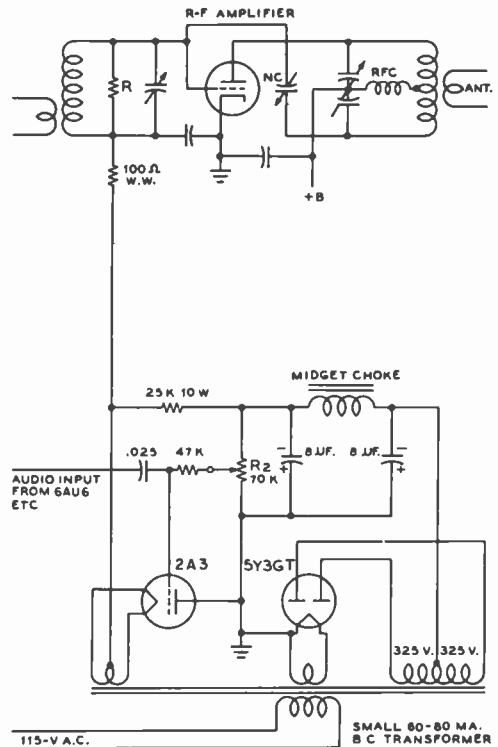

Figure 3

GRID-BIAS MODULATOR CIRCUIT

A comparatively small amount of audio power will be required to modulate the amplifier stage 100 percent. An audio amplifier having 20 watts output will be sufficient to modulate an amplifier with one kilowatt input. Proportionately smaller amounts of audio will be required for lower-powered stages. However, the audio amplifier that is being used as the grid modulator should, in any case, either employ low-plate-resistance tubes such as 2A3's, employ degenerative feedback from the output stage to one of the preceding stages of the speech amplifier, or be resistance loaded with a resistor across the secondary of the modulation transformer. This provision of low driving impedance in the grid modulator is to ensure good regulation in the audio driver for the grid-modulated stage because the grid impedance of the stage varies widely over the audio cycle.

A practical circuit for obtaining grid-bias

modulation is shown in figure 3. The modulator and bias regulator tube have been combined in a single 2A3 tube.

The regulator-modulator tube operates as a cathode-follower. The average d-c voltage on the control grid is controlled by the 70,000-ohm wirewound potentiometer and this potentiometer adjusts the average grid bias on the modulated stage. However, a-c signal voltage is also impressed on the control grid of the tube and since the cathode follows this a-c wave the incoming speech wave is superimposed on the average grid bias, thus effecting grid-bias modulation of the r-f amplifier stage. An audio voltage swing is required on the grid of the 2A3 of approximately the same peak value as will be required as bias-voltage swing on the grid-bias modulated stage.

With the normal amount of comparatively tight antenna coupling to the modulated stage, an unmodulated carrier efficiency of 40 percent can be obtained, with substantially distortion-free modulation up to practically 100 percent.

Tuning the Grid-Bias Modulated Stage The most satisfactory procedure for tuning a stage for grid-bias modulation of the class-C type is as follows. The amplifier should first be neutralized, and any possible tendency toward parasitics under any condition of operation should be eliminated. Then the antenna should be coupled to the plate circuit, the grid bias should be run up to the maximum available value, and the plate voltage and excitation should be applied. The grid-bias voltage should then be reduced until the amplifier draws the approximate amount of plate current it is desired to run, and modulation corresponding to about 80 percent is then applied. If the plate current kicks up when modulation is applied, the grid bias should be reduced; if the plate meter kicks down, increase the grid bias.

When the amount of bias voltage has been found (by adjusting the fine control (R_2) on the bias supply) where the plate meter remains constant with modulation, it is more than probable that the stage will be drawing either too much or too little input. The antenna coupling should then be either increased or decreased (depending on whether

the input was too little or too much, respectively) until the input is more nearly the correct value. The bias should then be re-adjusted until the plate meter remains constant with modulation as before. By slight jockeying back and forth of antenna coupling and grid bias, a point can be reached where the tubes are running at rated plate dissipation, and where the plate milliammeter on the modulated stage remains substantially constant with modulation.

The linearity of the stage should then be checked by any of the conventional methods; the trapezoidal pattern method employing a cathode-ray oscilloscope is probably the most satisfactory. The check with the trapezoidal pattern will allow the determination of the proper amount of gain to employ on the speech amplifier.

Screen-Grid Modulation Amplitude modulation may be accomplished by varying the screen-grid voltage in a class-C amplifier which employs a pentode, beam tetrode, or other type of screen-grid tube. The modulation obtained in this way is not especially linear as the impedance of the screen grid with respect to the modulating signal is nonlinear. However, *screen-grid modulation* does offer other advantages and the linearity is quite adequate for communications work.

There are two significant and worthwhile advantages of screen-grid modulation for communications work: (1) The excitation requirements for an amplifier which is to be screen modulated are not at all critical, and good regulation of the excitation voltage is not required. The normal rated grid-circuit operating conditions specified for class-C c-w operation are quite adequate for screen-grid modulation. (2) The audio modulating power requirements for screen-grid modulation are relatively low.

A screen-grid modulated r-f amplifier operates as an efficiency-modulated amplifier, the same as does a class-B linear amplifier and a grid-modulated stage. Hence, *plate circuit* loading is relatively critical as in any efficiency-modulated stage, and must be adjusted to the correct value if normal power output with full modulation capability is to be obtained. As in the case of any efficiency-modulated stage, the operating efficiency at

the peak of the modulation cycle will be between 70 and 80 percent, with efficiency at the carrier level (if the stage is operating in the normal manner with full carrier) about half of the peak-modulation value.

Screen-Grid Impedance Instead of being linear with respect to modulating voltage, as is the plate circuit of a plate-modulated class-C amplifier, the screen grid presents approximately a square-law impedance to the modulating signal over the region of signal excursion where the screen is positive with respect to ground. This nonlinearity may be explained in the following manner: At the carrier level of a conventional screen-modulated stage the plate-voltage swing of the modulated tube is one-half the voltage swing at peak-modulation level. This condition must exist in any type of conventional efficiency-modulated stage if 100 percent positive modulation is to be attainable. Since the plate-voltage swing is at half amplitude, and since the screen voltage is at half its full modulation value, the screen current is relatively low. But at the positive modulation peak the screen voltage is approximately doubled, and the plate-voltage swing also is at twice the carrier amplitude. Due to the increase in plate-voltage swing with rising screen voltage, the screen current increases more than linearly with rising screen voltage.

Another factor which must be considered in the design of a screen-modulated stage, if full modulation is to be obtained, is that the power output of a screen-grid stage with zero screen voltage is still relatively large. Hence, if anything approaching full modulation on negative peaks is to be obtained, the screen potential must be made negative with respect to ground on negative modulation peaks. In the usual types of beam tetrode tubes the screen potential must be 20 to 50 volts negative with respect to ground before cutoff of output is obtained. This condition further complicates the problem of obtaining good linearity in the audio modulating voltage for the screen-modulated stage, since the screen voltage must be driven negative with respect to ground over a portion of the cycle. Hence the screen draws no current over a portion of the modulating cycle, and over the major portion of the

cycle when the screen does draw current, it presents approximately a square-law impedance.

The cathode-follower modulator circuit of figure 4 is capable of giving good quality screen-grid modulation, and in addition the circuit provides convenient adjustments for the carrier level and the output level on negative modulation peaks. This latter control (P_2), allows the amplifier to be adjusted in such a manner that negative-peak clipping cannot take place, yet the negative modulation peaks may be adjusted to a level just above that at which sideband splatter will occur.

The Cathode-Follower Modulator The cathode follower is ideally suited for use as the modulator for a screen-grid stage since it acts as a relatively low-impedance source of modulating voltage for the screen-grid circuit. In addition the cathode-follower modulator allows the supply voltage both for the modulator and for the screen grid of the modulated tube to be obtained from the high-voltage supply for the plate of the screen-grid tube or beam tetrode. In the usual case the plate supply for the cathode follower, and hence for the screen grid of the modulated tube, may be taken from the bleeder on the high-voltage power supply. It is important that a bypass capacitor be used from the plate of the cathode-follower modulator to ground.

The voltage applied to the plate of the cathode follower should be about 100 volts greater than the rated screen voltage for the tetrode tube as a c-w class-C amplifier.

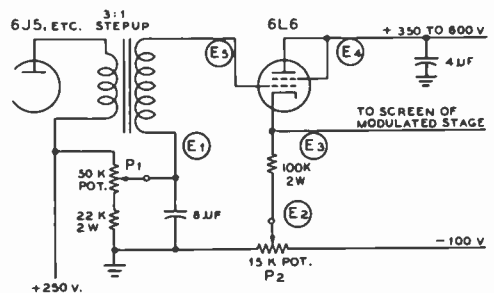

Figure 4

CATHODE-FOLLOWER SCREEN-MODULATION CIRCUIT

Then potentiometer (P_1) in figure 4 should be adjusted until the carrier-level screen voltage on the modulated stage is about one-half the rated screen voltage specified for the tube as a class-C c-w amplifier. The current taken by the screen of the modulated tube under carrier conditions will be about one-fourth the normal screen current for c-w operation.

The only current taken by the cathode follower itself will be that which will flow through the 100,000-ohm resistor between the cathode of the 6L6 modulator and the negative supply. The current taken from the bleeder on the high-voltage supply will be the carrier-level screen current of the tube being modulated (which current passes of course through the cathode follower) plus that current which will pass through the 100,000-ohm resistor.

The loading of the modulated stage should be adjusted until the input to the tube is about 50 percent greater than the rated plate dissipation of the tube or tubes in the stage. If the carrier-level screen voltage value is correct for linear modulation of the stage, the loading will have to be somewhat *greater* than that amount of loading which gives maximum output from the stage. The stage may then be modulated by applying an audio signal to the grid of the cathode-follower modulator, while observing the modulated envelope on an oscilloscope.

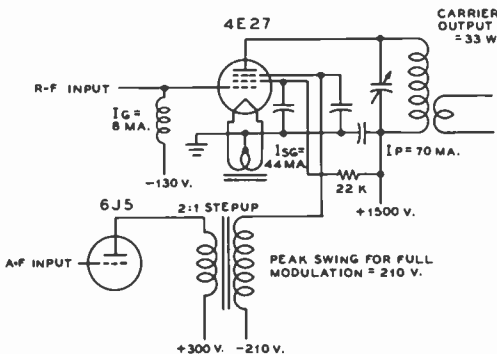

Figure 5

AMPLIFIER WITH SUPPRESSOR-GRID MODULATION

Recommended operating conditions for linear suppressor-grid modulation of a 4E27/5-125B stage are given on the drawing.

Note that the correct plate current for an efficiency-modulated amplifier is only slightly less than the out-of-resonance plate current of the stage. Hence carrier-level screen voltage must be low so that the out-of-resonance plate current will not be too high, and relatively heavy antenna coupling must be used so that the operating plate current will be near the out-of-resonance value, and so that the operating input will be slightly greater than 1.5 times the rated plate dissipation of the tube or tubes in the stage. Since the carrier efficiency of the stage will be only 35 to 40 percent, the tubes will be operating with plate dissipation of approximately the rated value without modulation.

Speech Clipping in the Modulated Stage The maximum r-f output of an efficiency-modulated stage is limited by the maximum permissible plate-voltage swing on positive modulation peaks. In the modulation circuit of figure 4 the *minimum* output is limited by the minimum voltage which the screen will reach on a negative modulation peak, as set by potentiometer P_2 . Hence the screen-grid-modulated stage, when using the modulator of figure 4, acts effectively as a speech clipper, provided the modulating signal amplitude is not too much more than that value which will accomplish full modulation. With correct adjustments of the operating conditions of the stage it can be made to clip positive and negative modulation peaks symmetrically. However, the inherent peak-clipping ability of the stage should *not* be relied upon as a means of obtaining a large amount of speech compression, since excessive audio distortion and excessive screen current on the modulated stage will result.

Characteristics of a Typical Screen-Modulated Stage An important characteristic of the screen-modulated stage, when using the cathode-follower modulator, is that excessive plate voltage on the modulated stage is not required.

As an example of a typical screen-modulated stage, full output of 75 watts of carrier may be obtained from an 813 tube operating with a plate potential of only 1250 volts. No increase in output from the 813

may be obtained by increasing the plate voltage, since the tube may be operated with full rated plate dissipation of 125 watts, with normal plate efficiency for a screen-modulated stage—37.5 percent, at the 1250-volt potential.

The operating conditions of a screen-modulated 813 stage are as follows:

- Plate voltage—1250 volts
- Plate current—160 ma
- Plate input—200 watts
- Grid current—11 ma
- Grid bias—-110 volts
- Carrier screen voltage—190 volts
- Carrier screen current—6 ma
- Power output—approx. 75 watts

With full 100-percent modulation the plate current decreases about 2 ma and the screen current increases about 1 ma; hence plate, screen, and grid current remain essentially constant with modulation. Referring to figure 4, which was the circuit used as modulator for the 813, E_1 measured + 155 volts, E_2 measured - 50 volts, E_3 measured + 190 volts, E_4 measured + 500 volts, and the rms swing at E_5 for full modulation measured 210 volts, which represents a peak swing of about 296 volts. Due to the high positive voltage, and the large audio swing, on the cathode of the 6L6 (triode-connected) modulator tube, it is important that the heater of this tube be fed from a separate filament transformer or filament winding.

Suppressor-Grid Modulation Still another form of efficiency modulation may be obtained by applying the audio modulating signal to the suppressor grid of a pentode class-C r-f amplifier (figure 5). Basically, *suppressor-grid modulation* operates in the same general manner as other forms of efficiency modulation; carrier plate-circuit efficiency is about 35 percent, and antenna coupling must be rather heavy. However, suppressor-grid modulation has one sizeable disadvantage, in addition to the fact that pentode tubes are not nearly so widely used as beam tetrodes which of course do not have the suppressor element. This disadvantage is that the screen-grid current to a suppressor-grid modulated amplifier is

rather high. The high screen current is a natural consequence of the rather high negative bias on the suppressor grid, which reduces the plate-voltage swing and plate current with a resulting increase in the screen current.

In tuning a suppressor-grid modulated amplifier, the grid bias, grid current, screen voltage, and plate voltage are about the same as for class-C c-w operation of the stage. But the suppressor grid is biased negatively to a value which reduces the plate-circuit efficiency to about one-half the maximum obtainable from the particular amplifier, with antenna coupling adjusted until the plate input is about 1.5 times the rated plate dissipation of the stage. It is important that the input to the screen grid be measured to make sure that the rated screen dissipation of the tube is not being exceeded. Then the audio signal is applied to the suppressor grid. In the normal application the audio voltage swing on the suppressor will be somewhat greater than the negative bias on the element. Hence suppressor-grid current will flow on modulation peaks, so that the source of audio signal voltage must have good regulation.

13-4 Input Modulation Systems

Constant-efficiency variable-input modulation systems operate by virtue of the addition of external power to the modulated stage to effect the modulation. There are two general classifications that come under this heading; those systems in which the additional power is supplied as audio-frequency energy from a modulator (usually called *plate-modulation systems*) and those systems in which the additional power to effect modulation is supplied as direct current from the plate supply.

Under the former classification comes *Heising* modulation (probably the oldest type of modulation to be applied to a continuous carrier), class-B plate modulation, and series modulation. These types of plate modulation are by far the easiest to get into operation, and they give a very good ratio of power input to the modulated stage to

power output; 65 to 80 percent efficiency is the general rule. It is for these two important reasons that these modulation systems, particularly class-B plate modulation, are at present the most popular for a-m communications work.

Modulation systems coming under the second classification have been widely applied to broadcast work. There are quite a few systems in this class. Two of the more widely used are the *Doberty* linear amplifier, and the *Terman-Woodyard* high-efficiency grid-modulated amplifier. Both systems operate by virtue of a carrier amplifier and a peak amplifier connected together by electrical quarter-wave lines. They will be described later in this section.

Plate Modulation Plate modulation is the application of the audio power to the *plate circuit* of an r-f amplifier. The r-f amplifier must be operated class C for this type of modulation in order to obtain a radio-frequency output which changes in exact accord with the variation in plate voltage. *The r-f amplifier is 100 percent modulated when the peak a-c voltage from the modulator is equal to the d-c voltage applied to the r-f tube.* The positive peaks of audio voltage increase the instantaneous plate voltage on the r-f tube to *twice* the d-c value, and the negative peaks reduce the voltage to zero.

The instantaneous plate *current* to the r-f stage also varies in accord with the modulating voltage. The peak alternating current in the output of a modulator must be equal to the d-c plate current of the class-C r-f stage at the point of 100 percent modulation. This combination of change in audio voltage and current can be most easily referred to in terms of *audio power in watts*.

In a sinusoidally modulated wave, the antenna current increases approximately 22 percent for 100 percent modulation with a pure tone input; an r-f meter in the antenna circuit indicates this increase in antenna current. The *average power* of the r-f wave increases 50 percent for 100 percent modulation, the efficiency remaining constant.

This indicates that in a plate-modulated radiotelephone transmitter, the audio-fre-

quency channel must supply this additional 50 percent increase in average power for sine-wave modulation. If the power input to the modulated stage is 100 watts, for example, the *average power* will increase to 150 watts at 100 percent modulation, and this additional 50 watts of power must be supplied by the *modulator* when plate modulation is used. The actual antenna power is a constant percentage of the total value of input power.

One of the advantages of plate (or power) modulation is the ease with which proper adjustments can be made in the transmitter. Also, there is less plate loss in the r-f amplifier for a given value of carrier power than with other forms of modulation because the plate efficiency is higher.

By properly matching the plate impedance of the r-f tube to the output of the modulator, the ratio of voltage and current swing to d-c voltage and current is automatically obtained. The modulator should have a peak voltage output equal to the average d-c plate voltage on the modulated stage. The modulator should also have a *peak* power output equal to the d-c plate input power to the modulated stage.

The *average* power output of the modulator will depend on the type of waveform. If the amplifier is being Heising modulated by a class-A stage, the modulator must have an average power output capability of one-half the input to the class-C stage. If the modulator is a class-B audio amplifier, the average power required of it may vary from one-quarter to more than one-half the class-C input depending on the waveform. However, the *peak* power output of any modulator must be equal to the class-C input to be modulated.

Heising Modulation *Heising* modulation is the oldest system of plate modulation, and usually consists of a class-A audio amplifier coupled to the r-f amplifier by means of a modulation choke, as shown in figure 6.

The d-c plate voltage and plate current of the r-f amplifier must be adjusted to a value which will cause the plate impedance to match the output of the modulator, since

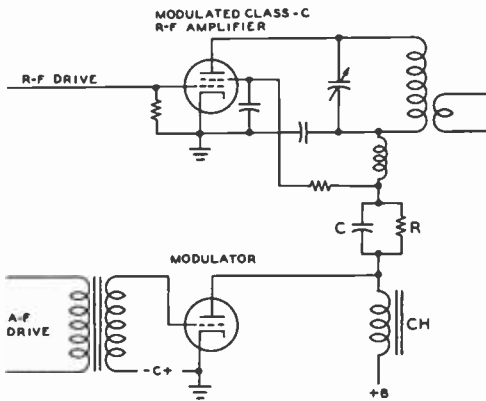

Figure 6

HEISING PLATE MODULATION

This type of modulation was the first form of plate modulation. It is sometimes known as "constant-current" modulation. Because of the effective 1:1 ratio of the coupling choke, it is impossible to obtain 100 percent modulation unless the plate voltage to the modulated stage is dropped slightly by resistor R. The capacitor (C) merely bypasses the audio around R, so that the full a-f output voltage of the modulator is impressed on the class-C stage.

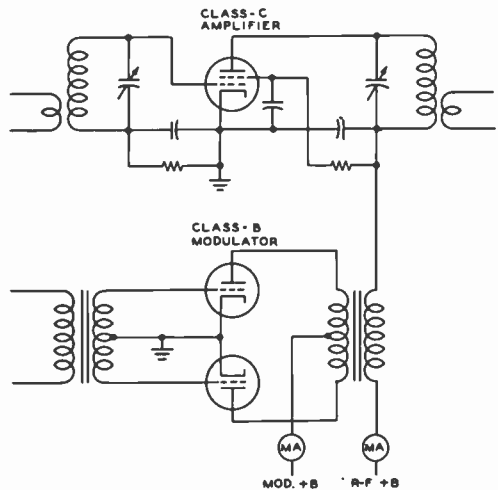

Figure 7

CLASS-B PLATE MODULATION

This type of modulation is the most flexible in that the loading adjustment can be made in a short period of time and without elaborate test equipment after a change in operating frequency of the class-C amplifier has been made.

the modulation choke gives a 1-to-1 coupling ratio. A series resistor, bypassed for audio frequencies by means of a capacitor, must be connected in series with the plate of the r-f amplifier to obtain modulation up to 100 percent. The peak output voltage of a class-A amplifier does not reach a value equal to the d-c voltage applied to the amplifier and, consequently, the d-c plate voltage impressed across the r-f tube must be reduced to a value equal to the maximum available a-c peak voltage if 100% modulation is to be obtained.

A higher degree of distortion can be tolerated in low-power emergency phone transmitters which use a pentode modulator tube, and the series resistor and bypass capacitor are usually omitted in such transmitters.

Class-B Plate Modulation High-level class-B plate modulation is the least expensive method of plate modulation. Figure 7 shows a conventional class-B plate-modulated class-C amplifier.

The statement that the modulator output power must be one-half the class-C input for

100 percent modulation is correct only if the waveform of the modulating power is a *sine wave*. Where the modulator waveform is unclipped speech waveforms, the average modulator power for 100 percent modulation is considerably less than one-half the class-C input. A detailed discussion of modulation transformer calculations is given in Chapter Six.

Power Relations in Speech Waveforms It has been determined experimentally that the ratio of peak-to-average power in a speech waveform is approximately 4 to 1 as contrasted to a ratio of 2 to 1 in a sine wave. This is due to the high harmonic content of such a waveform, and to the fact that this high harmonic content manifests itself by making the wave unsymmetrical and causing sharp peaks or "fingers" of high energy content to appear. Thus for unclipped speech, the *average* modulator plate current, plate dissipation, and power output are approximately one-half the sine wave values for a given *peak* output power.

Both peak power and average power are necessarily associated with waveform. *Peak* power is just what the name implies; the power at the peak of a wave. Peak power, although of the utmost importance in modulation, is of no great significance in a-c power work, except insofar as the *average* power may be determined from the peak value of a known waveform.

There is no time element implied in the definition of peak power; peak power may be instantaneous—and for this reason average power, which is definitely associated with time, is the important factor in plate dissipation. It is possible that the peak power of a given waveform be several times the average value; for a sine wave, the peak power is twice the average value and for unclipped speech the peak power is approximately four times the *average* value. For 100 percent modulation, the *peak* (instantaneous) audio power must equal the class-C input, although the average power for this value of peak varies widely depending on the modulation waveform, being greater than 50 percent for speech that has been clipped and filtered, 50 percent for a sine wave, and about 25 percent for typical unclipped speech tones.

Plate-and-Screen Modulation When *only* the plate of a screen-grid tube is modulated, it is difficult to obtain high-percentage linear modulation under ordinary conditions. The plate current of such a stage is not linear with plate voltage. However, if the screen is modulated simultaneously with the plate, the instantaneous screen voltage drops in proportion to the drop in the plate voltage, and linear modulation can then be obtained. Four satisfactory circuits for accomplishing combined plate and screen modulation are shown in figure 8.

The screen r-f bypass capacitor (C_2) should not have a greater value than 0.005 μfd , preferably not larger than 0.001 μfd . It should be large enough to bypass effectively all r-f voltage without short-circuiting high-frequency audio voltages. The plate bypass capacitor can be of any value from 0.002 μfd to 0.005 μfd . The screen-dropping resistor (R_1) should reduce the applied high voltage to the value specified for operating the particular tube in the circuit. Capacitor

C_1 is seldom required yet some tubes may require this capacitor in order to keep C_2 from attenuating the high frequencies. Different values between .0002 and .002 μfd . should be tried for best results.

Figure 8C shows another method which uses a third winding on the modulation transformer, through which the screen grid is connected to a low-voltage power supply. The ratio of turns between the two output windings depends on the type of screen-grid tube which is being modulated. Normally it will be such that the screen voltage is being modulated 60 percent when the plate voltage is receiving 100 percent modulation.

If the screen voltage is derived from a dropping resistor (*not* a divider) that is bypassed for r.f. but not a.f., it is possible to secure quite good modulation by applying modulation only to the plate. Under these conditions, the screen tends to modulate itself, the screen voltage varying over the audio cycle as a result of the screen impedance increasing with plate voltage, and decreasing with a decrease in plate voltage. This circuit arrangement is illustrated in figure 8B.

A similar application of this principle is shown in figure 8D. In this case the screen voltage is fed directly from a low-voltage supply of the proper potential through choke L. A conventional filter choke having an inductance from 10 to 20 henrys will be satisfactory for L.

To afford protection of the tube when plate voltage is not applied but screen voltage is supplied from the exciter power supply, when using the arrangement of figure 8D, a resistor of 3000 to 10,000 ohms can be connected in series with choke L. In this case the screen supply voltage should be at least 1.5 times as much as is required for actual screen voltage, and the value of resistor is chosen such that with normal screen current the drop through the resistor and choke will be such that normal screen voltage will be applied to the tube. When the plate voltage is removed the screen current will increase greatly and the drop through resistor R will increase to such a value that the screen voltage will be lowered to the point where the screen dissipation on the tube will not be exceeded. However, the supply voltage and value of resistor R must

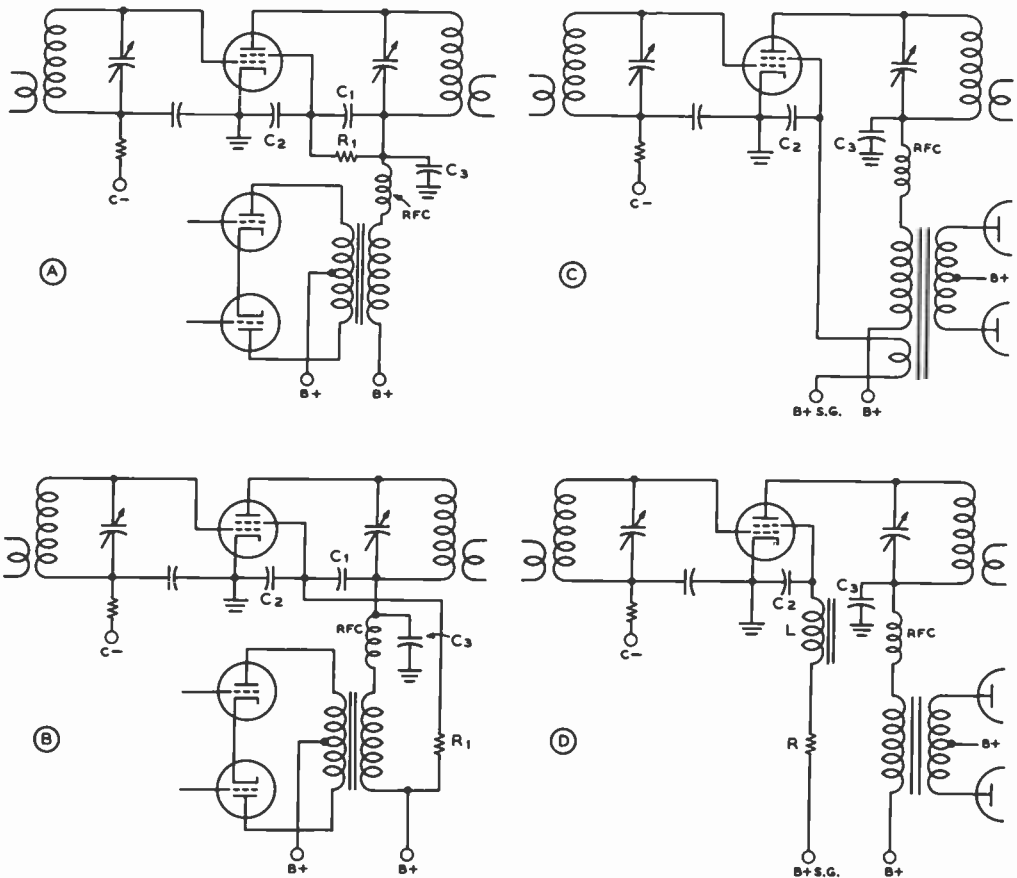

Figure 8

PLATE MODULATION OF A BEAM-TETRODE OR SCREEN-GRID TUBE

These alternative arrangements for plate modulation of tetrodes or pentodes are discussed in detail in the text. The arrangements shown at B or D are recommended for most applications.

be chosen carefully so that the maximum rated screen dissipation cannot be exceeded. The maximum possible screen dissipation using this arrangement is equal to: $W = E^2/4R$ where E is the screen supply voltage and R is the combined resistance of the resistor in figure 8D and the d-c resistance of the choke (L). It is wise, when using this arrangement to check, using the above formula, to see that the value of W obtained is less than the maximum rated screen dissipation of the tube or tubes used in the modulated stage. This same system can of course also be used in figuring the screen supply

circuit of a pentode or tetrode amplifier stage where modulation is not to be applied.

The modulation transformer for plate-and-screen modulation, when utilizing a dropping resistor as shown in figure 8A, is similar to the type of transformer used for any plate-modulated transmitter. The combined screen and plate current is divided into the plate voltage in order to obtain the class-C amplifier load impedance. The peak audio power required to obtain 100-percent modulation is equal to the d-c power input to the screen, screen resistor, and plate of the modulated r-f stage.

13-5 Cathode Modulation

Cathode modulation offers a workable compromise between the good plate efficiency but expensive modulator of high-level plate modulation, and the poor plate-efficiency but inexpensive modulator of grid modulation. Cathode modulation consists essentially of a mixture of the two.

The efficiency of the average well-designed plate-modulated transmitter is in the vicinity of 75 to 80 percent, with a compromise at perhaps 77.5 percent. On the other hand, the efficiency of a good grid-modulated transmitter may run from 28 to perhaps 40 percent with the average falling at about 34 percent. Now since cathode modulation consists of simultaneous grid and plate modulation, in phase with each other, we can theoretically obtain any efficiency from about 34 to 77.5 percent from our cathode-modulated stage, depending on the relative percentages of grid and plate modulation.

Since the system is a compromise between the two fundamental modulation arrangements, a value of efficiency approximately half way between the two would seem to be the best compromise. Experience has proved this to be the case. A compromise efficiency of about 56.5 percent, roughly half way between the two limits, has proved to be optimum. Calculation has shown that this value of efficiency can be obtained from a cathode-modulated amplifier when the audio-frequency modulating power is approximately 20 percent of the d-c input to the cathode-modulated stage.

An Economical Series Cathode Modulator Series cathode modulation is ideally suited as an economical modulating arrangement for a high-power triode c-w transmitter. The modulator can be constructed quite compactly and for a minimum component cost since no power supply is required for it. When it is desired to change over from c-w to 'phone, it is only necessary to cut the series modulator into the cathode-return circuit of the c-w amplifier stage. The plate voltage for the modulator tubes and for the speech amplifier is taken from the cathode voltage drop of the modulated stage across the modulator unit.

Figure 9 shows the circuit of such a modulator, designed to cathode-modulate a class-C amplifier using high- μ triodes.

Cathode Modulation of Tetrodes Cathode modulation has not proved too satisfactory for use with beam tetrode tubes. This is a result of the small excitation and grid-swing requirements for such tubes, plus the fact that some means for holding the screen voltage at the potential of the cathode as far as audio is concerned is usually necessary. Because of these factors, cathode modulation is not recommended for use with tetrode r-f amplifiers.

13-6 The Doherty and the Terman-Woodyard Modulated Amplifiers

These two amplifiers will be described together since they operate on very similar principles. Figure 10 shows a greatly simplified schematic diagram of the operation of both types. Both systems operate by virtue of a *carrier tube*, (V_1 in both figures 10 and 11) which supplies the unmodulated carrier, and whose output is reduced to supply negative peaks, and a *peak tube*, (V_2) whose function is to supply approximately half the positive peak of the modulation cycle and whose additional function is to lower the load impedance on the carrier tube so that it will be able to supply the other half of the positive peak of the modulation cycle.

The peak tube is able to increase the output of the carrier tube by virtue of an impedance-inverting line between the plate circuits of the two tubes. This line is designed to have a characteristic impedance of one-half the value of load into which the carrier tube operates under the carrier conditions. Then a load of one-half the characteristic impedance of the quarter-wave line is coupled into the output. By experience with quarter-wave lines in antenna-matching circuits we know that such a line will vary the impedance at one end of the line in such a manner that the geometric mean between the two terminal impedances will be equal to the characteristic impedance of the line. Thus, if we have a value of load of *one-half* the characteristic impedance of the line at

one end, the other end of the line will present a value of *twice* the characteristic impedance of the lines to carrier tube V_1 .

This is the situation that exists under the carrier conditions when the peak tube merely floats across the load end of the line and contributes no power. Then as a positive peak of modulation comes along, the peak tube starts to contribute power to the load until at the peak of the modulation cycle it is contributing enough power so that the impedance at the load end of the line is equal to R , instead of the $R/2$ that is presented under the carrier conditions. This is true because at a positive modulation peak (since it is delivering full power) the peak tube subtracts a negative resistance of $R/2$ from the load end of the line.

Now, since under the peak condition of modulation the load end of the line is terminated in R ohms instead of $R/2$, the impedance at the *carrier-tube* will be *reduced* from $2R$ ohms to R ohms. This again is due to the impedance-inverting action of the line. Since the load resistance on the carrier tube has been reduced to half the carrier value, its output at the peak of the modulation cycle will be doubled. Thus we have the necessary condition for a 100-percent modulation peak; the amplifier will deliver four times as

much power as it does under the carrier conditions.

On negative modulation peaks the peak tube does not contribute; the output of the carrier tube is reduced until, on a 100 percent negative peak, its output is zero.

The Electrical Quarter-Wave Line

While an electrical quarter-wave line (consisting of a pi network with the inductance and capacitance units having a reactance equal to the characteristic impedance of the line) does have the desired impedance-inverting effect, it also has the undesirable effect of introducing a 90° phase shift across such a line. If the shunt elements are capacitances, the phase shift across the line lags by 90° ; if they are inductances, the phase shift leads by 90° . Since there is an undesirable phase shift of 90° between the plate circuits of the carrier and peak tubes, an equal and opposite phase shift must be introduced in the exciting voltage of the grid circuits of the two tubes so that the resultant output in the plate circuit will be in phase. This additional phase shift has been indicated in figure 10 and a method of obtaining it has been shown in figure 11.

Comparison Between Doherty and Terman-Woodyard Amplifiers

The difference between the Doherty linear amplifier and the Terman-Woodyard grid-modulated amplifier is the same as the difference between any linear and grid-modulated stages. Modulated r.f. is applied to the grid circuit of the Doherty linear amplifier with the carrier tube biased to cutoff and the peak tube biased to the point where it draws substantially zero plate current at the carrier condition.

In the Terman-Woodyard grid-modulated amplifier the carrier tube runs class-C with comparatively high bias and high plate efficiency, while the peak tube again is biased so that it draws almost no plate current. Unmodulated r.f. is applied to the grid circuits of the two tubes and the modulating voltage is inserted in series with the fixed bias voltages. From one-half to two-thirds as much *audio* voltage is required at the grid of the peak tube as is required at the grid of the carrier tube.

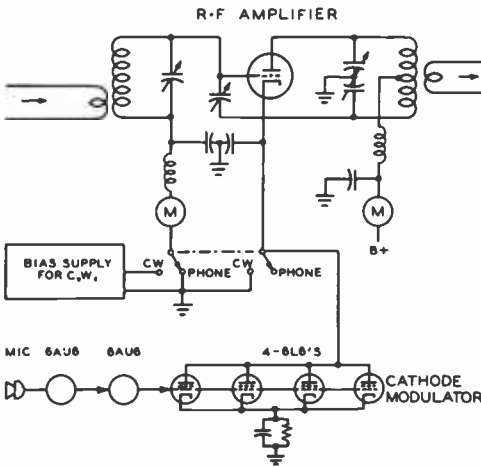

Figure 9

CATHODE-MODULATOR INSTALLATION SHOWING PHONE-CW TRANSFER SWITCH

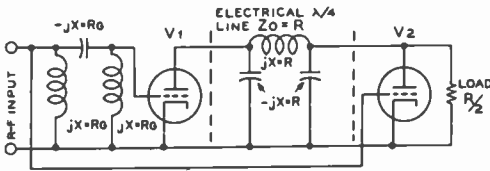

Figure 10

DIAGRAMMATIC REPRESENTATION OF THE DOHERTY LINEAR

Operating Efficiencies The resting carrier efficiency of the grid-modulated amplifier may run as high as is obtainable in any class-C stage—80 percent or better. The resting carrier efficiency of the linear will be about as good as is obtainable in any class-B amplifier—60 to 70 percent. The over-all efficiency of the bias-modulated amplifier at 100 percent modulation will run about 75 percent; of the linear—about 60 percent.

In figure 11 the plate tank circuits are detuned enough to give an effect equivalent to the shunt elements of the quarter-wave "line" of figure 10. At resonance, coils L_1 and L_2 in the grid circuits of the two tubes have each an inductive reactance equal to the capacitive reactance of capacitor C_1 . Thus we have the effect of a pi network consisting of shunt inductances and series capacitance. In the plate circuit we want a phase shift of the same magnitude but in the opposite direction; so our series element is inductance L_3 whose reactance is equal to the characteristic impedance desired of the network. Then the plate tank capacitors of the two tubes (C_2 and C_3) are increased an amount past resonance, so that they have a capacitive reactance equal to the inductive reactance of the coil L_3 . It is quite important that there be no coupling between the inductors.

Although both these types of amplifiers are highly efficient and require no high-level audio equipment, they are difficult to adjust—particularly so on the higher frequencies—and it would be an extremely difficult problem to design a multiband transmitter employing the circuit. However, the grid-bias modulation system has advantages for the high-power transmitter which will be operated on a single frequency band.

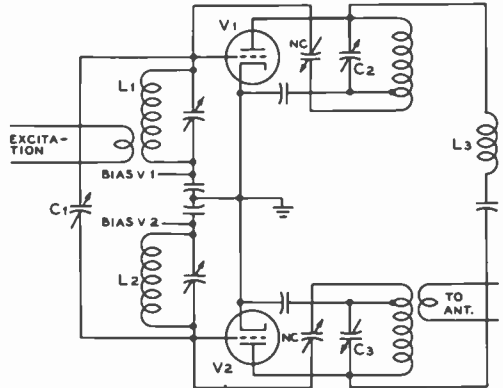

Figure 11

SIMPLIFIED SCHEMATIC OF A "HIGH-EFFICIENCY" AMPLIFIER

The basic system, comprising a "carrier" tube (V_1) and a "peak" tube (V_2) interconnected by lumped-constant quarter-wave lines, is the same for either grid-bias modulation or for use as a linear amplifier of a modulated wave.

Other High-Efficiency Modulation Systems Many other high-efficiency modulation systems have been described since about 1936. The majority of these, however, have received little application either by commercial interests or by amateurs. In most cases the circuits are difficult to adjust, or they have other undesirable features which make their use impracticable alongside the more conventional modulation systems. Nearly all these circuits have been published in the *I.E.E.E. Proceedings* and the interested reader can refer to them in back copies of that journal.

13-7 Speech Clipping

Speech waveforms are characterized by frequently recurring high-intensity peaks of very short duration. These peaks will cause overmodulation if the average level of modulation on loud syllables exceeds approximately 30 percent. Careful checking into the nature of speech sounds has revealed that these high-intensity peaks are due primarily to the vowel sounds. Further research has revealed that the vowel sounds add little to intelligibility, the major contribution to intelligibility coming from the consonant sounds such as *v, b, k, s, t,* and *l*. Measure-

ments have shown that the power contained in these consonant sounds may be down 30 db or more from the energy in the vowel sounds in the same speech passage. Obviously, then, if we can increase the relative energy content of the consonant sounds with respect to the vowel sounds it will be possible to understand a signal modulated with such a waveform in the presence of a much higher level of background noise and interference. Experiment has shown that it is possible to accomplish this desirable result simply by cutting off or *clipping* the high-intensity peaks and thus building up in a relative manner the effective level of the weaker sounds.

Such clipping theoretically can be accomplished simply by increasing the gain of the speech amplifier until the average level of modulation on loud syllables approaches 90 percent. This is equivalent to increasing the speech power of the consonant sounds by about 10 times or, conversely, we can say that 10 db of clipping has been applied to the voice wave. However, the clipping when accomplished in this manner *will produce*

higher order sidebands known as "splatter," and the transmitted signal would occupy a relatively tremendous spectrum width. So another method of accomplishing the desirable effects of clipping must be employed.

A considerable reduction in the amount of splatter caused by a moderate increase in the gain of the speech amplifier can be obtained by phasing the signal from the speech amplifier to the amplitude-modulated transmitter such that the high-intensity peak occurs on *upward* or positive modulation. Overloading on positive modulation peaks produces less splatter than the negative-peak clipping which occurs with overloading on the negative peaks of modulation. This aspect of the problem has been discussed in more detail in the section on *Speech Waveform Dissymmetry* earlier in this chapter. The effect of deriving proper speech polarity from the speech amplifier is shown in figure 12.

A much more desirable and effective method of obtaining speech clipping is actually to employ a clipper circuit in the earlier stages of the speech amplifier, and then to filter out

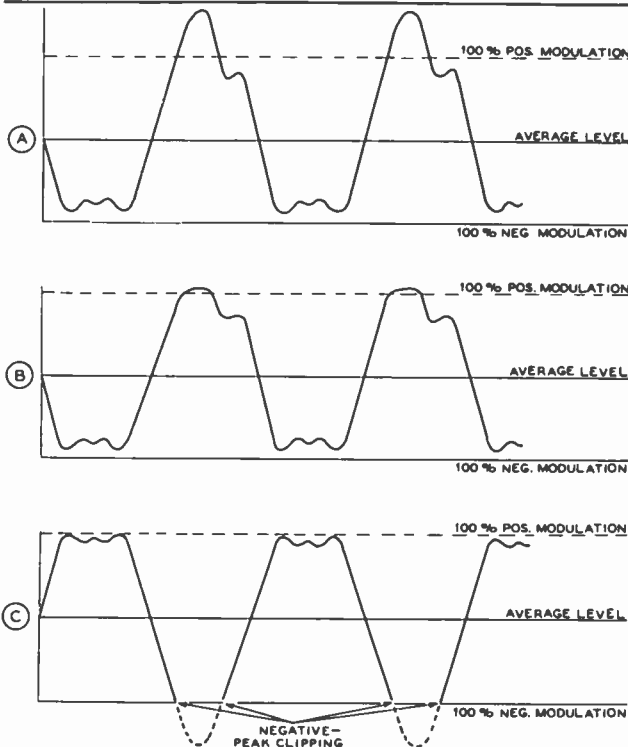

Figure 12
SPEECH-WAVEFORM
AMPLITUDE
MODULATION

Showing the effect of using the proper polarity of a speech wave for modulating an a-m transmitter. A shows the effect of proper speech polarity on a transmitter having an upward modulation capability of greater than 100 percent. B shows the effect of using proper speech polarity on a transmitter having an upward modulation capability of only 100 percent. Both these conditions will give a clean signal without objectionable splatter. C shows the effect of the use of improper speech polarity. This condition will cause serious splatter due to negative-peak clipping in the modulated-amplifier stage.

the objectionable distortion components by means of a sharp low-pass filter having a cutoff frequency of approximately 3000 Hz. Tests on *clipper-filter* speech systems have shown that 6 db of clipping on voice is just noticeable, 12 db of clipping is quite acceptable, and values of clipping from 20 to 25 db are tolerable under such conditions that a high degree of clipping is necessary to get through heavy QRM or QRN. A signal with 12 db of clipping doesn't sound quite *natural* but it is not unpleasant to listen to and is much more readable than an unclipped signal in the presence of strong interference.

The use of a clipper-filter in the speech amplifier of an a-m transmitter, to be completely effective, requires that phase shift between the clipper-filter stage and the final modulated amplifier be kept to a minimum. However, if there is phase shift after the clipper-filter the system does not completely break down. The presence of phase shift merely requires that the audio gain following the clipper-filter be reduced to the point

where the *cant* apparent on the clipped speech waves still cannot cause overmodulation. This effect is illustrated in figures 13 and 14.

The *cant* appearing on the tops of the square waves leaving the clipper-filter centers about the clipping level. Hence, as the frequency being passed through the system is lowered, the amount by which the peak of the *canted* wave exceeds the clipping level is increased.

Phase-Shift Correction In a normal a-m transmitter having a moderate amount of phase shift the *cant* applied to the tops of the waves will cause overmodulation on frequencies below those for which the gain following the clipper-filter has been adjusted unless remedial steps have been taken. The following steps are advised:

1. Introduce bass *suppression* into the speech amplifier *ahead* of the clipper-filter.
2. *Improve* the low-frequency response

Figure 13

ACTION OF A CLIPPER-FILTER ON A SPEECH WAVE

Drawing A shows the incoming speech wave before it reaches the clipper stage. B shows the output of the clipper-filter, illustrating the manner in which the peaks are clipped and then the sharp edges of the clipped wave removed by the filter. C shows the effect of phase shift in the stages following the clipper-filter and the manner in which the a-m transmitter may be adjusted for 100-percent modulation of the "canted" peaks of the wave, the sloping top of the wave reaching about 70% modulation.

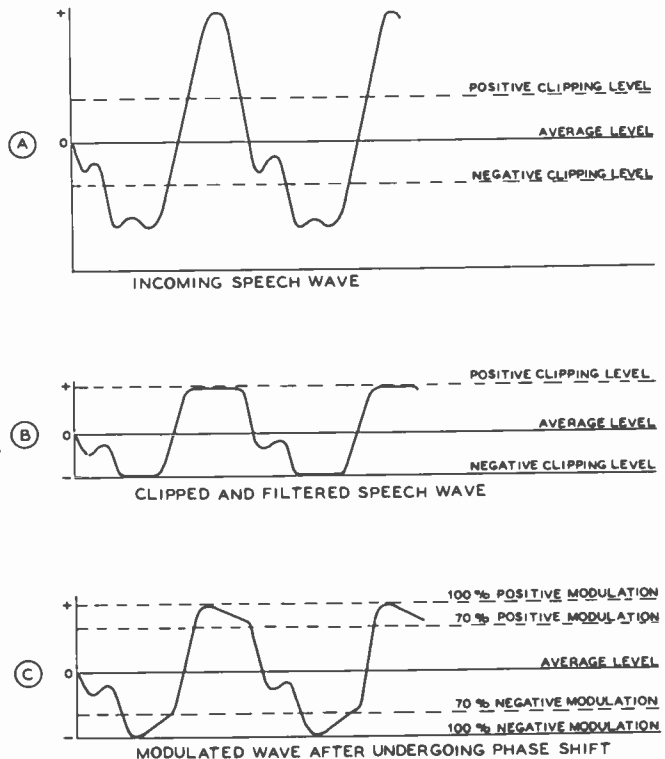

characteristic insofar as it is possible in the stages *following* the clipper-filter. Feeding the plate current to the final amplifier through a choke rather than through the secondary of the modulation transformer will help materially.

Even with the normal amount of improvement which can be attained through the steps mentioned above there will still be an amount of wave cant which must be compensated in some manner. This compensation can be done in either of two ways. The first and simpler way is as follows:

1. Adjust the speech gain *ahead* of the clipper-filter until with normal talking into the microphone the distortion being introduced by the clipper-filter circuit is quite apparent but not objectionable. This amount of distortion will be apparent to the normal listener when 10 to 15 db of clipping is taking place.
2. Tune a selective communications receiver about 15kHz to one side or the other of the frequency being transmitted. Use a short antenna or no antenna at all on the receiver so that the transmitter is not blocking the receiver.
3. Again, with normal talking into the microphone, adjust the gain *following* the clipper-filter to the point where the sideband splatter is being heard, and then slightly back-off the gain after the clipper-filter until the splatter disappears.

If the phase shift in the a-m transmitter or modulator is not excessive, the adjustment procedure given above will allow a clean signal to be radiated regardless of any reasonable voice level being fed into the microphone.

If a cathode-ray oscilloscope is available the modulated envelope of the a-m transmitter should be checked with 30- to 70-Hz sawtooth waves on the horizontal axis. If the upper half of the envelope appears in general the same as the drawing of figure 13C, all is well and phase-shift is not excessive. However, if much more slope appears on the tops of the waves than is illustrated in this figure, it will be well to apply the second step in compensation in order to ensure that side-

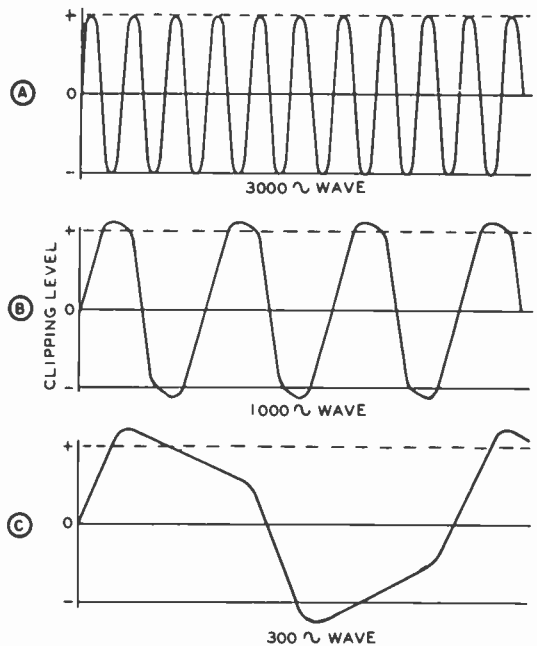

Figure 14

ILLUSTRATING THE EFFECT OF PHASE SHIFT AND FILTERED WAVES OF DIFFERENT FREQUENCY

Sketch A shows the effect of a clipper and a filter having a cutoff of about 3500 Hz on a wave of 3000 Hz. Note that no harmonics are present in the wave so that phase shift following the clipper-filter will have no significant effect on the shape of the wave. B and C show the effect of phase shift on waves well below the cutoff frequency of the filter. Note that the "cant" placed on the top of the wave causes the peak value to rise higher and higher above the clipping level as the frequency is lowered. It is for this reason that bass suppression before the clipper stage is desirable. Improved low-frequency response following the clipper-filter will reduce the phase shift and therefore the "canting" of the wave at the lower voice frequencies.

band splatter cannot take place and to afford a still higher average percentage of modulation. This second step consists of the addition of a high-level *splatter suppressor* such as is illustrated in figure 15.

The use of a high-level splatter suppressor after a clipper-filter system will afford the result shown in figure 16 since such a device will not permit the negative-peak clipping which the wave cant caused by audio-system phase shift can produce. The high-level splat-

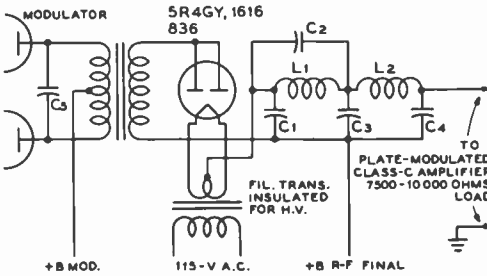

Figure 15

HIGH-LEVEL A-M SPLATTER SUPPRESSOR

This circuit is effective in reducing splatter caused by negative-peak clipping in the modulated amplifier stage. The use of a two-section filter as shown is recommended, although either a single m-derived or a constant-k section may be used for greater economy. Suitable chokes, along with recommended capacitor values, are available from several manufacturers.

ter suppressor operates by virtue of the fact that it will not permit the plate voltage on the modulated amplifier to go completely to zero regardless of the incoming signal amplitude. Hence negative-peak clipping with its attendant splatter cannot take place. Such a device can, of course, also be used in a transmitter which does not incorporate a clipper-filter system. However, the full increase in average modulation level without serious distortion, afforded by the clipper-filter system, will not be obtained.

A word of caution should be noted at this time in the case of tetrode-final modulated amplifier stages which afford screen-voltage modulation by virtue of a tap or a separate winding on the modulation transformer such as is shown in figure 8C of this chapter. If such a system of modulation is in use, the high-level splatter suppressor shown in fig-

ure 15 will not operate properly since negative-peak clipping in the modulated stage can take place when the screen voltage goes too low.

Clipper Circuits Two effective low-level clipper circuits are shown in figures 17 and 18. The circuit of figure 17 is transistorized, with a modified input circuit suitable for use with high-impedance (crystal) microphones having an average output level of about 10 millivolts, peak-to-peak. Three amplifier stages boost the microphone level to about 5 volts peak-to-peak and the output of the last stage is fed to a double-diode clipper, utilizing a pair of germanium diodes. A maximum of 12 to 14 db of clipping may be achieved with this circuit, and the two-stage speech amplifier must therefore be considered as a part of the clipper circuit since it compensates for the loss of gain incurred in the clipping process. A simple RC lowpass filter starts to round-off the waveform at about 2.5 kHz. The output level of about 0.5 volt peak-to-peak is ample to drive most speech amplifiers with gain to spare. The degree of clipping is adjusted by variation of the microphone level in conjunction with the proper setting of the gain potentiometer.

A vacuum-tube version of this circuit is shown in figure 18, making use of a 6AL5 double-diode series clipper and a commercially made low-pass filter. This configuration provides somewhat better high-frequency cutoff characteristics than the simple filter of figure 17. The actual performance of both circuits is about the same.

The circuit of figure 18 has an *adjust clipping* control in addition to the *adjust gain* potentiometer. The gain control deter-

Figure 16

ACTION OF HIGH-LEVEL SPLATTER SUPPRESSOR

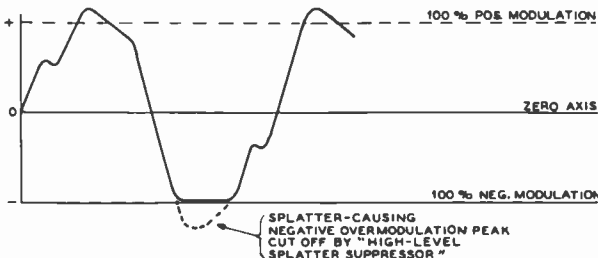

A high-level splatter suppressor may be used in a transmitter without a clipper-filter to reduce negative-peak clipping, or such a unit may be used following a clipper-filter to allow a higher average modulation level by eliminating the negative-peak clipping which the wave cant caused by phase shift might produce.

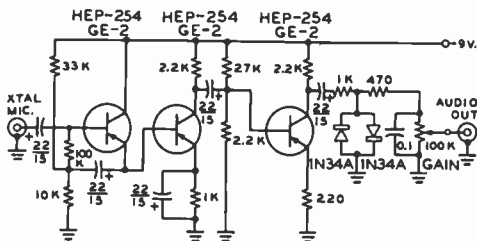

Figure 17

SPEECH CLIPPER FOR USE WITH CRYSTAL MICROPHONE

This simple clipper/amplifier may be inserted between microphone and existing speech amplifier. Power is supplied by a 9-volt transistor radio battery. Transistors are either Motorola (HEP type) or General Electric (GE type).

mines the modulation level of the transmitter. This control should be set so that over-modulation is impossible, regardless of the amount of clipping used. Once the gain control has been set, the clipping control may be used to set the modulation level to any percentage below 100 percent. As the modulation level is decreased, more and more clipping is introduced into the circuit, until a full 12 to 14 db of clipping is used. This means the gain control may be advanced some 12 db past the point at which the clipping action started. Clipping action should start at about 90-percent modulation when a sine wave is used for circuit adjustment purposes. In all cases, the use of a monitor oscilloscope to adjust clipping level is highly recommended.

These circuits are *not recommended* for single-sideband transmitters and suitable

compression circuits for SSB equipment are covered in a later section.

High-Level Filters Even though we may have cut off all frequencies above 3 or 3.5 kHz through the use of a filter system such as shown in the circuits of figures 17 and 18, higher frequencies may again be introduced into the modulated wave by distortion in stages following the speech amplifier. Harmonics of the incoming audio frequencies may be generated in the driver stage for the modulator; they may be generated in the plate circuit of the modulator; or they may be generated by nonlinearity in the modulated amplifier itself.

Regardless of the point in the system following the speech amplifier where the high audio frequencies may be generated, these frequencies can still cause a broad signal to be transmitted even though all frequencies above 3000 or 3500 Hz have been cut off in the speech amplifier. The effects of distortion in the audio system *following* the speech amplifier can be eliminated quite effectively through the use of a *post-modulator* filter. Such a filter may be used between the modulator plate circuit and the r-f amplifier which is being modulated (figure 19).

13-8 Speech Compression

Volume compression or a form of automatic gain control may be used to maintain constant voice intensity over a large range of audio input to the speech system of a voice transmitter. This is accomplished by making the system gain a function of the

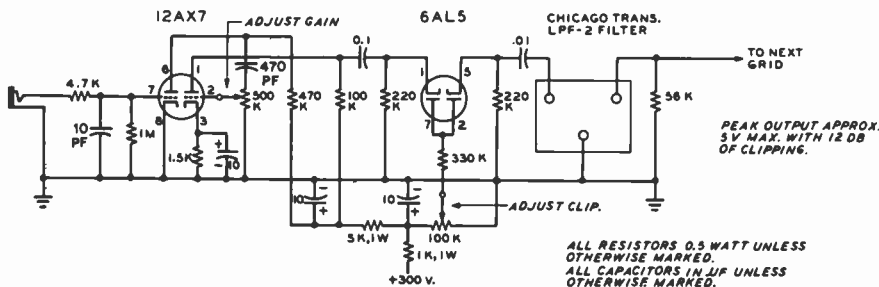

Figure 18

CLIPPER FILTER USING 6AL5 STAGE

PEAK OUTPUT APPROX. 5V MAX. WITH 12 DB OF CLIPPING.

ALL RESISTORS 0.5 WATT UNLESS OTHERWISE MARKED. ALL CAPACITORS IN UF UNLESS OTHERWISE MARKED.

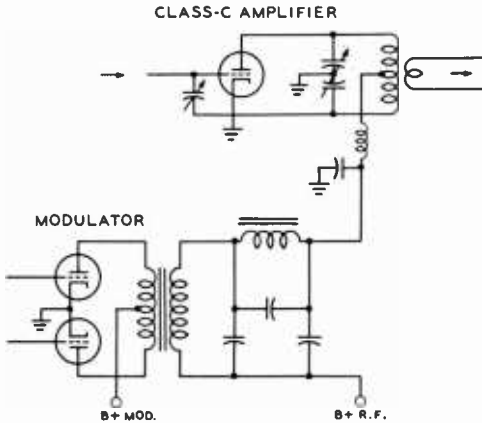

Figure 19

ADDITIONAL HIGH-LEVEL LOW-PASS FILTER TO FOLLOW MODULATOR WHEN A LOW-LEVEL CLIPPER FILTER IS USED

Suitable choke, along with recommended capacitor values, is available from several manufacturers.

average variations in speech amplitude. Practical systems rectify and filter the speech signal as it passes through the speech amplifier and apply the d-c component of the signal to a gain-control element in the amplifier. The compression system usually has a time constant such that the control voltage is held at a steady value between syllables and words. Simple compressors usually exhibit an attack time of about 10 milliseconds and a release time of 300 milliseconds or longer. Compression range of the order of 20 to 35 decibels is realizable in practical circuits, corresponding roughly to the dynamic range of the human speaking voice. Reverberation and background noise usually limit the practical compression range to 15 decibels or so.

Compression is usually preferred in SSB systems as contrasted to clipping because of reduced distortion and better threshold intelligibility for weak-signal reception.

A basic compression amplifier is shown in figure 20. A sample of the audio signal is taken and rectified to provide a negative control voltage which fluctuates with average voice level. The compression control voltage is applied as bias to the control grid of a variable- μ pentode amplifier. Com-

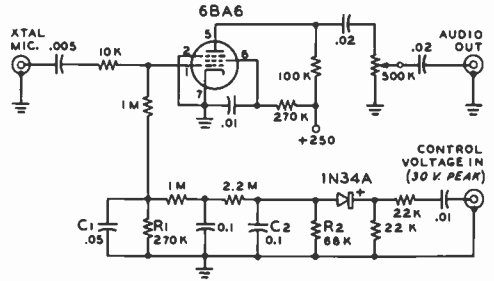

Figure 20

SPEECH COMPRESSOR FOR USE WITH CRYSTAL MICROPHONE

This basic volume compressor derives control voltage from a high-level stage in the existing speech amplifier. A signal of about 30 volts peak is required to provide up to 20 decibels of compression. Compressor is designed to be placed between microphone and station amplifier.

pression is substantially proportional to the average input signal and thus holds the output level at a constant level. Rise time is regulated by the choice of R_2 and C_2 , while release time is controlled by R_1 and C_1 .

A simple and inexpensive compression circuit suitable for amplitude modulation or SSB is shown in figure 21. A two stage 12AX7 preamplifier is used, the input circuit of which is shunted with a silicon transistor working as a d-c amplifier whose gain is inversely proportional to the audio output voltage of the amplifier. The compression amplifier is suitable for use with a dynamic microphone having an impedance as high as 0.05 megohm.

A driving signal of about 0.8 volts r.m.s. at point A will overcome the threshold level of the system and an audio input of 10 mV at the microphone jack will produce about 10 db of compression. Rise time is about 30 mS and release time is about 100 mS, both of which are controlled by the 1-pf capacitor in the base circuit of the transistor.

A solid-state compressor/amplifier is shown in figure 22. It is designed to be used with a dynamic microphone having an impedance in the range of 500 to 2000 ohms, and provides a compression range of approximately 20 db.

Compression is achieved by change of gain brought about by variation of the emitter

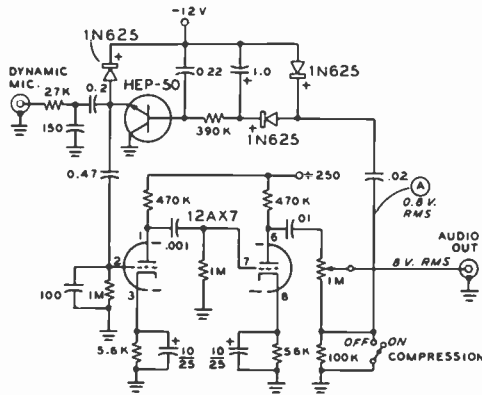

Figure 21

TRANSISTOR-CONTROLLED SPEECH COMPRESSOR

A single transistor (Motorola HEP-type) acts as a d-c amplifier, receiving its driving signal from point A. Maximum compression of 20 decibels is achieved using a dynamic microphone.

bypass capacitance in the first-stage transistor. With the emitter load impedance about twice the value of the collector load, and with unbypassed emitter, the first stage gain is about 0.5. In series with the emitter bypass capacitor (C_1) is a variable resistance composed of a diode network. Control voltage derived from the output of the amplifier is applied to the diode which, in effect, isolates bypass capacitor C_1 from signal voltages, effectively lowering the stage gain. Maximum stage gain is approximately the ratio of the collector load resistance (2.7K) to the forward resistance of the cathode control diode (D_1) and minimum stage gain is about 0.5.

Small coupling capacitors are used between amplifier stages to limit the low-frequency response of the system.

A similar amplifier having somewhat higher gain and lower distortion is shown in figure 23. A FET is used for the control element.

Bass Suppression Most of the power represented by ordinary speech (particularly the male voice) lies below 1000 Hz. If all frequencies below 400 or 500 Hz are eliminated or substantially attenuated, there is a considerable reduction in power but insignificant reduction in intelligibility. This means that the speech level may be increased considerably without overmodulation or overload of the audio system. In addition, if speech processing is used, attenuation of the lower audio frequencies before the clipper or compressor will reduce phase shift and canting of the clipper output.

A simple method of bass suppression is to reduce the size of the interstage coupling capacitors in a resistance-coupled amplifier. Figure 24 shows the frequency characteristics caused by such a suppression circuit. A second simple bass-suppression circuit is to place a small iron-core filter choke from grid to ground in a speech-amplifier stage, as shown in figure 25.

Modulated-Amplifier Distortion The systems described in the preceding paragraphs will have no effect in reducing a broad signal caused by nonlinearity in the modulated amplifier or in linear-amplifier stages. Even though the modulating waveform impressed on the modulated stage may be distortion free, if

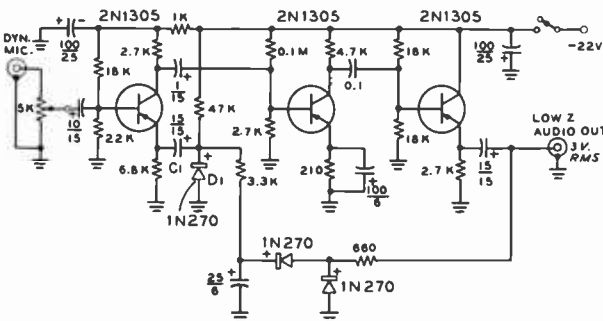

Figure 22

SOLID-STATE COMPRESSOR AMPLIFIER FOR DYNAMIC MICROPHONE

Compression is brought about by variation of emitter bypass capacitor C_1 in the first-stage transistor. Variable-resistance network is driven by two 1N270 diodes as a voltage doubler of output signal taken from emitter of the third-stage 2N1305 emitter follower.

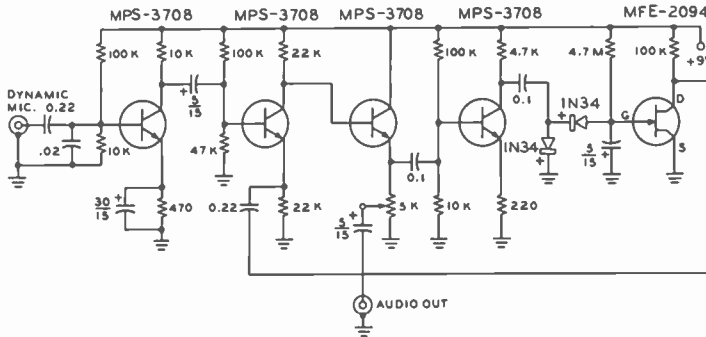

Figure 23

COMPRESSOR AMPLIFIER USING FET IN CONTROL LOOP

Emitter bypass variation of second amplifier stage is controlled by FET amplifier, with signal taken from drain element. MPS and MFE transistors by Motorola.

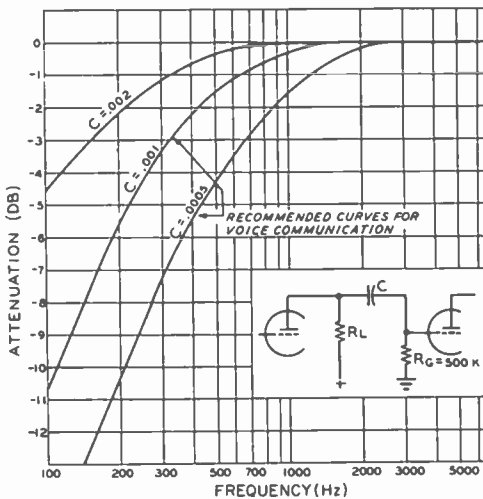

Figure 24

BASS-ATTENUATION CHART

Frequency attenuation caused by various values of coupling capacitor with a grid resistor of 0.5 megohm in the following stage ($R_G > R_L$)

the modulated amplifier is nonlinear, distortion will be generated in the amplifier. The only way in which this type of distortion

can be corrected is by making the modulated amplifier more linear. Degenerative feedback which includes the modulated amplifier in the loop will help in this regard.

Plenty of grid excitation and high grid bias will go a long way toward making a plate-modulated class-C amplifier linear, although such operating conditions will make more difficult the problem of TVI reduction. If this still does not give adequate linearity, the preceding buffer stage may be modulated 50 percent or so at the same time and in the same phase as the final amplifier. The use of a grid resistor to obtain the majority of the bias for a class-C stage will improve its linearity.

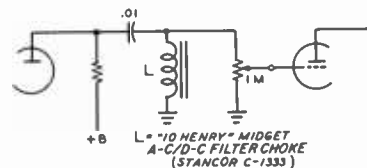

Figure 25

USE OF PARALLEL INDUCTANCE FOR BASS SUPPRESSION

Frequency and Phase Modulation

Exciter systems for f-m and single-sideband transmission are basically similar in that modulation of the signal in accordance with the intelligence to be transmitted is normally accomplished at a relatively low level. Then the intelligence-bearing signal is amplified to the desired power level for ultimate transmission. True, amplifiers for the two types of signals are basically different; linear amplifiers of the class-A or class-B type being used for SSB signals, while class-C or nonlinear class-B amplifiers may be used for f-m amplification. But the principle of low-level modulation and subsequent amplification is standard for both types of transmission.

14-1 Frequency Modulation

The use of *frequency modulation* and the allied system of *phase modulation* has become of increasing importance in recent years. For amateur vhf communication, frequency and phase modulation offer important advantages in the reduction of broadcast and TV interference, in reduction of random noise, and in the elimination of the costly high-level modulation equipment most commonly employed with amplitude modulation. For broadcast work, frequency modulation offers an improvement in signal-to-noise ratio for the high field intensities available in the local-coverage area of f-m and TV broadcast stations.

Vhf commercial two-way mobile radio is now standardized on channelized frequency-modulation techniques which provide superior rejection to random noise, interference, and fading as compared to conventional a-m systems. When the amplitude of the r-f signal is held constant (limited) and the intelligence transmitted by varying the frequency or phase of the signal, some of the disruptive effects of noise can be eliminated. In addition, audio squelch circuits silence noise peaks and background effects in the receiver until an intelligible signal appears on the frequency. The combination of noise rejection and squelch control provides superior range for a given primary power, as compared to an equivalent a-m power allocation.

Amateur vhf f-m techniques are based on the channel concept. Transmitters and receivers are mainly crystal controlled on a given frequency and random tuning techniques common to the lower frequency amateur bands are absent. F-m channels on the 2-meter band, for example, are usually 60 kHz apart, starting at about 146.04 MHz by general agreement, and are commonly 100 kHz apart in the 450-MHz range. A spot frequency of 29.60 MHz is often used for f-m operation in the 10-meter band, and numerous f-m channels are in use on the 6-meter band above 52.5 MHz.

In this chapter various points of difference between frequency-modulation and amplitude-modulation transmission and reception will be discussed and the advantages of

frequency-modulation for certain types of communication pointed out. Since the distinguishing features of the two types of transmission lie entirely in the modulating circuits at the transmitter and in the detector and limiter circuits in the receiver, these parts of the communication system will receive the major portion of attention.

Modulation *Modulation* is the process of altering a radio wave in accord with the intelligence to be transmitted. The nature of the intelligence is of little importance as far as the process of modulation is concerned; it is the *method*, by which this intelligence is made to give a distinguishing characteristic to the radio wave which will enable the receiver to convert it back into intelligence, that determines the type of modulation being used.

Figure 1 is a drawing of an r-f carrier amplitude-modulated by a sine-wave audio voltage. After modulation the resultant modulated r-f wave is seen still to vary about the zero axis at a constant rate, but the strength of the individual r-f waves is proportional to the amplitude of the modulation voltage.

In figure 2, the carrier of figure 1 is shown frequency-modulated by the same modulating voltage. Here it may be seen that modulation voltage of one polarity causes the carrier frequency to decrease, as shown by the fact that the individual r-f waves of the carrier are spaced farther apart. A modulating voltage of the opposite polarity causes the frequency to increase, and this is shown by the r-f waves being compressed together to allow more of them to be completed in a given time interval.

Figures 1 and 2 reveal two very important characteristics about amplitude- and frequency-modulated waves. First, it is seen that while the amplitude (power) of the signal is varied in a-m transmission, no such variation takes place in frequency modulation. In many cases this advantage of frequency modulation is probably of equal or greater importance than the widely publicized noise-reduction capabilities of the system. When 100 percent amplitude modulation is obtained, the average power output of the transmitter must be increased by 50 percent. This additional output must be

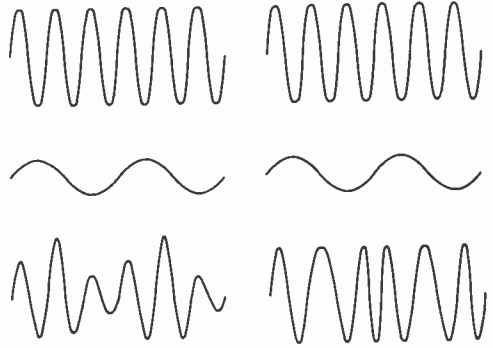

Figure 1

Figure 2

A-M AND F-M WAVES

Figure 1 shows a sketch of the scope pattern of an amplitude-modulated wave at the bottom. The center sketch shows the modulating wave and the upper sketch shows the carrier wave.

Figure 2 shows at the bottom a sketch of a frequency-modulated wave. In this case the center sketch also shows the modulating wave and the upper sketch shows the carrier wave. Note that the carrier wave and the modulating wave are the same in either case, but that the waveform of the modulated wave is quite different in the two cases.

supplied either by the modulator itself, in the high-level system, or by operating one or more of the transmitter stages at such a low output level that they are capable of producing the additional output without distortion in the low-level system. On the other hand, a frequency-modulated transmitter requires an insignificant amount of power from the modulator and needs no provision for increased power output on modulation peaks. All of the stages between the oscillator and the antenna may be operated as high-efficiency class-B or class-C amplifiers or frequency multipliers.

Carrier-Wave Distortion The second characteristic of f-m and a-m waves revealed

by figures 1 and 2 is that both types of modulation result in distortion of the r-f carrier. That is, after modulation, the r-f waves are no longer sine waves, as they would be if no frequencies other than the fundamental carrier frequency were present. It may be shown in the amplitude-modulation case illustrated, that there are only two additional frequencies present, and these are

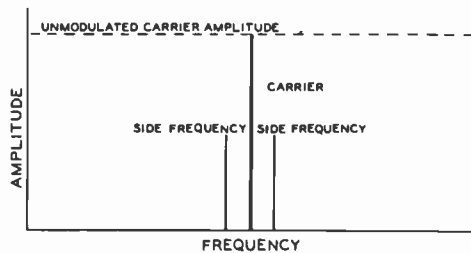

Figure 3

A-M SIDE FREQUENCIES

For each a-m modulating frequency, a pair of side frequencies is produced. The side frequencies are spaced away from the carrier by an amount equal to the modulation frequency, and their amplitude is directly proportional to the amplitude of the modulation. The amplitude of the carrier does not change under modulation.

the familiar *side frequencies*, one located on each side of the carrier, and each spaced from the carrier by a frequency interval equal to the modulation frequency. In regard to frequency and amplitude, the situation is as shown in figure 3. The strength of the carrier itself does not vary during modulation, but the strength of the side frequencies depends on the percentage of modulation. At 100 percent modulation the power in the side frequencies is equal to one-half that of the carrier.

Under frequency modulation, the carrier wave again becomes distorted, as shown in figure 2. But, in this case, many more than two additional frequencies are formed. The first two of these frequencies are spaced from the carrier by the modulation frequency, and the additional side frequencies are located out on each side of the carrier and are also spaced from each other by an amount equal to the modulation frequency. Theoretically, there are an infinite number of side frequencies formed, but, fortunately, the strength of those beyond the frequency *swing* of the transmitter under modulation is relatively low.

One set of side frequencies that might be formed by frequency modulation is shown in figure 4. Unlike amplitude modulation, the strength of the component at the carrier frequency varies widely in frequency modulation and it may even disappear entirely under certain conditions. The variation of strength of the carrier component is useful

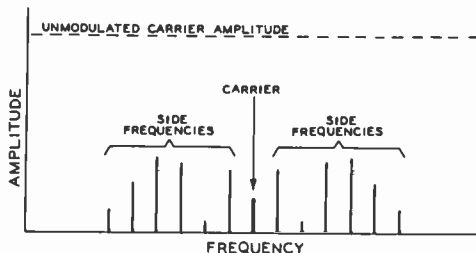

Figure 4

F-M SIDE FREQUENCIES

With frequency modulation, each modulation frequency component causes a large number of side frequencies to be produced. The side frequencies are separated from each other and the carrier by an amount equal to the modulation frequency, but their amplitude varies greatly as the amount of modulation is changed. The carrier strength also varies greatly with frequency modulation. The side frequencies shown represent a case where the deviation each side of the "carrier" frequency is equal to five times the modulating frequency. Other amounts of deviation with the same modulation frequency would cause the relative strengths of the various sidebands to change widely.

in measuring the amount of frequency modulation, and will be discussed in detail later in this chapter.

One of the great advantages of frequency modulation over amplitude modulation is the reduction in noise at the receiver which the system allows. If the receiver is made responsive only to changes in frequency, a considerable increase in signal-to-noise ratio is made possible through the use of frequency modulation, when the signal is of greater strength than the noise. The noise-reducing capabilities of frequency modulation arise from the inability of noise to cause appreciable frequency modulation of the noise-plus-signal voltage which is applied to the detector in the receiver.

F-M Terms Unlike amplitude modulation, the term *percentage modulation* means little in f-m practice, unless the receiver characteristics are specified. There are, however, three terms, *deviation*, *modulation index*, and *deviation ratio*, which convey considerable information concerning the character of the f-m wave.

Deviation is the amount of frequency shift each side of the unmodulated carrier

frequency which occurs when the transmitter is modulated. Deviation is ordinarily measured in kilohertz, and in a properly operating f-m transmitter it will be directly proportional to the amplitude of the modulating signal. When a symmetrical modulating signal is applied to the transmitter, equal deviation each side of the resting frequency is obtained during each cycle of the modulating signal, and the total frequency range covered by the f-m transmitter is sometimes known as the *swing*. If, for instance, a transmitter operating on 1000 kHz has its frequency shifted from 1000 kHz to 1010 kHz, back to 1000 kHz, then to 990 kHz, and again back to 1000 kHz during one cycle of the modulating wave, the *deviation* would be 10 kHz and the *swing* 20 kHz.

The *modulation index* of an f-m signal is the ratio of the deviation to the audio modulating frequency, when both are expressed in the same units. Thus, in the example above if the signal is varied from 1000 kHz to 1010 kHz to 990 kHz, and back to 1000 kHz at a rate (frequency) of 2000 times a second, the modulation index would be 5, since the deviation (10 kHz) is 5 times the modulating frequency (2 kHz).

The relative strengths of the f-m carrier and the various side frequencies depend directly on the modulation index, these relative strengths varying widely as the modulation index is varied. In the preceding example, for instance, side frequencies occur on the high side of 1000 kHz at 1002, 1004, 1006, 1008, 1010, 1012, etc., and on the low frequency side at 998, 996, 994, 992, 990, 988, etc. In proportion to the unmodulated carrier strength (100 percent), these side frequencies have the following strengths, as indicated by a modulation index of 5: 1002 and 998—33 percent; 1004 and 996—5 percent; 1006 and 994—36 percent; 1008 and 992—39 percent; 1010 and 990—26 percent; 1012 and 998—13 percent. The carrier strength (1000 kHz) will be 18 percent of its modulated value. Changing the amplitude of the modulating signal will change the deviation, and thus the modulation index will be changed, with the result that the side frequencies, while still located in the same places, will have different strength values from those given above.

The *deviation ratio* is similar to the modulation index in that it involves the ratio between a modulating frequency and deviation. In this case, however, the deviation in question is the peak frequency shift obtained under full modulation, and the audio frequency to be considered is the maximum audio frequency to be transmitted. When the maximum audio frequency to be transmitted is 5000 Hz, for example, a deviation ratio of 3 would call for a peak deviation of 3×5000 , or 15 kHz at full modulation. The noise-suppression capabilities of frequency modulation are directly related to the deviation ratio. As the deviation ratio is increased, the noise suppression becomes better if the signal is somewhat stronger than the noise. Where the noise approaches the signal in strength, however, low deviation ratios allow communication to be maintained in many cases where high-deviation-ratio frequency modulation and conventional amplitude modulation are incapable of giving service. This assumes that a narrow-band f-m receiver is in use. For each value of r-f signal-to-noise ratio at the receiver, there is a maximum deviation ratio which may be used, beyond which the output audio signal-to-noise ratio decreases. Up to this critical deviation ratio, however, the noise suppression becomes progressively better as the deviation ratio is increased.

For high-fidelity f-m broadcasting purposes, a deviation ratio of 5 is ordinarily used, the maximum audio frequency being 15,000 Hz, and the peak deviation at full modulation being 75 kHz. Since a swing of 150 kHz is covered by the transmitter, it is obvious that wide-band f-m transmission must necessarily be confined to the vhf range or higher, where room for the signals is available.

In the case of television sound, the deviation ratio is 1.67; the maximum modulation frequency is 15,000 Hz, and the transmitter deviation for full modulation is 25 kHz. The sound carrier frequency in a standard TV signal is located exactly 4.5 MHz higher than the picture carrier frequency. In the *intercarrier* TV sound system, which is widely used, this constant difference between the picture carrier and the sound carrier is employed within the receiver to obtain an f-m subcarrier at 4.5 MHz. This 4.5 MHz sub-

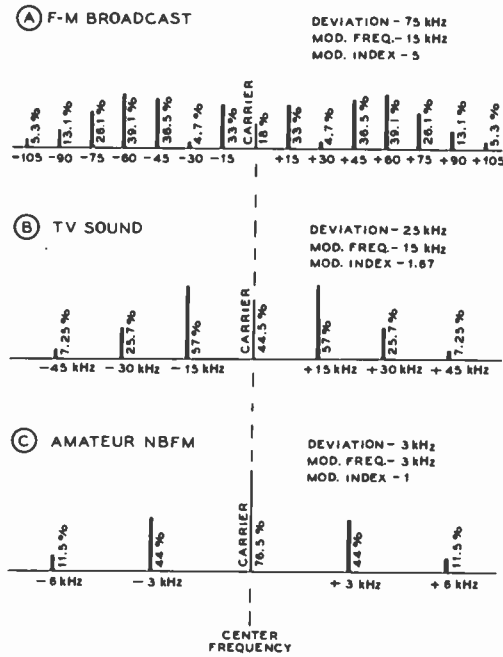

Figure 5

EFFECT OF F-M MODULATION INDEX

Showing the side-frequency amplitude and distribution for the three most common modulation indices used in f-m work. The maximum modulating frequency and maximum deviation are shown in each case.

carrier then is demodulated by the f-m detector to obtain the sound signal which accompanies the picture.

Narrow-Band F-M Transmission Narrow-band f-m transmission has become standardized for use by the mobile services such as police, fire, and taxicab communications, and is also authorized for amateur work in portions of each of the amateur radiotelephone bands. A maximum deviation of 15 kHz has been standardized for the mobile and commercial communication services, while a maximum deviation of 3 kHz is authorized for amateur nbfm h-f communication. For a maximum audio frequency of 3000 Hz, the maximum deviation ratio is 1.0. For vhf f-m, the deviation ranges from 3 kHz to 15 kHz for a deviation ratio of up to 5.0.

The newer 2-meter f-m gear employs a deviation of 5 kHz.

Bandwidth Required by Frequency Modulation

As the above discussion has indicated, many side frequencies are set up when a radio-frequency carrier is frequency modulated; theoretically, in fact, an infinite number of side frequencies is formed. Fortunately, however, the amplitudes of those side frequencies falling outside the frequency range over which the transmitter is swung are so small that most of them may be ignored. In f-m transmission, when a complex modulating wave (speech or music) is used, still additional side frequencies resulting from a beating together of the various frequency components in the modulating wave are formed. This is a situation that does not occur in amplitude modulation and it might be thought that the large number of side frequencies thus formed might make the frequency spectrum produced by an f-m transmitter prohibitively wide. Analysis shows, however, that the additional side frequencies are of very small amplitude, and, instead of increasing the bandwidth, modulation by a complex wave actually reduces the effective bandwidth of the f-m wave. This is especially true when speech modulation is used, since most of the power in voiced sounds is concentrated at low frequencies in the vicinity of 400 Hz.

The bandwidth required in an f-m receiver is a function of a number of factors, both theoretical and practical. Basically, the bandwidth required is a function of the deviation ratio and the maximum frequency of modulation, although the practical consideration of drift and ease of receiver tuning also must be considered. Shown in figure 5 are the frequency spectra (carrier and sideband frequencies) associated with the standard f-m broadcast signal, the TV sound signal, and an amateur-band narrow-band f-m signal with full modulation using the highest permissible modulating frequency in each case. It will be seen that for low deviation ratios the receiver bandwidth should be at least four times the maximum frequency deviation, but for a deviation ratio of 5 the receiver bandwidth need be only about 2.5 times the maximum frequency deviation.

14-2 Direct F-M Circuits

Frequency modulation may be obtained either by the direct method, in which the frequency of an oscillator is changed directly by the modulating signal, or by the indirect method which makes use of phase modulation. Phase-modulation circuits will be discussed in section 14-3.

A successful frequency-modulated transmitter must meet two requirements: (1) The frequency deviation must be symmetrical about a fixed frequency, for symmetrical modulation voltage. (2) The deviation must be directly proportional to the amplitude of the modulation, and independent of the modulation frequency. There are several methods of direct frequency modulation which will fulfill these requirements. Some of these methods will be described in the following paragraphs.

Reactance Modulators One of the most practical ways of obtaining direct frequency modulation is through the use of a *reactance modulator*. In this arrangement the modulator output circuit is connected across the oscillator tank circuit, and made to appear as either a capacitive or inductive reactance by exciting the modulator with a voltage which either leads or lags the oscillator tank voltage by 90 degrees. The leading or lagging input voltage causes a corresponding leading or lagging output current, and the output circuit appears as capacitive or inductive reactance across the oscillator tank circuit. When the transconductance of the modulator is varied by varying one of the element voltages, the magnitude of the reactance across the oscillator tank is varied. By applying audio modulating voltage to one of the elements, the transconductance (and hence the frequency) may be varied at an audio rate. When properly designed and operated, the reactance modulator provides linear frequency modulation, and is capable of producing large amounts of deviation.

There are numerous possible configurations of the reactance modulator circuit. The difference in the various arrangements lies principally in the type of phase-shifting circuit used to give a grid voltage which is

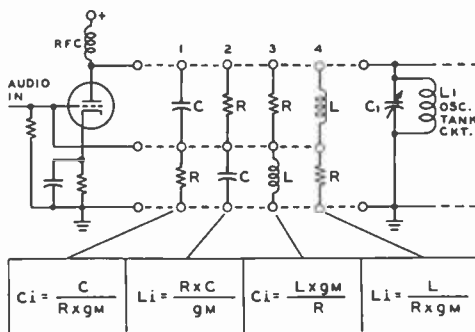

Figure 6

FOUR POSSIBLE PLATE-LOAD ARRANGEMENTS FOR REACTANCE MODULATOR

A combination of a reactance and a resistance form a quadrature circuit, so-called because the r-f voltage developed across the output is leading or lagging the r-f current in the plate circuit by approximately 90 degrees. The four arrangements possible are shown in the diagram, together with the formulas for calculating the apparent resulting inductance or capacitance.

in phase quadrature with the r-f voltage at the modulator plate (figure 6).

Figure 7 is a diagram of two of the most popular forms of reactance-tube modulators. The modulator tube, which is usually a pentode such as a 6BA6, 6AU6, or 6CL6, has its plate coupled through a blocking capacitor (C_1) to the "hot" side of the oscillator grid circuit. Another blocking capacitor (C_2) feeds r-f to the phase-shifting network ($R-C_3$) in the modulator grid circuit. If the resistance of R is made large in comparison with the reactance of C_3 at the oscillator frequency, the current through the $R-C_3$ combination will be nearly in phase with the voltage across the tank circuit, and the voltage across C_3 will lag the oscillator tank voltage by almost 90 degrees. The result of the 90-degree lagging voltage on the modulator grid is that its plate current lags the tank voltage by 90 degrees, and the reactance tube appears as an inductance in shunt with the oscillator inductance, thus raising the oscillator frequency.

The phase-shifting capacitor (C_3) can consist of the input capacitance of the modulator tube and stray capacitance between

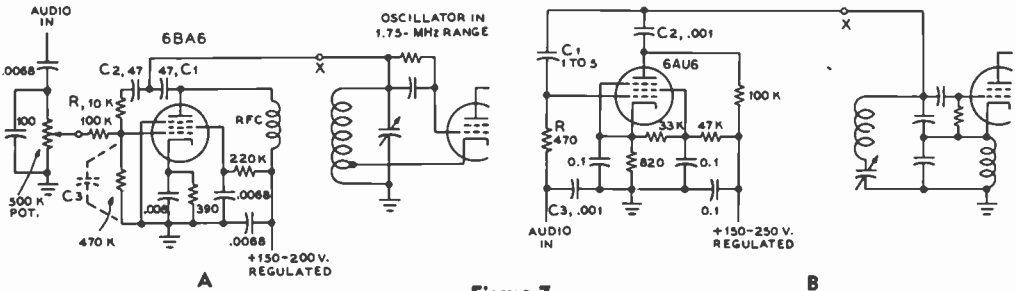

Figure 7

REACTANCE-TUBE MODULATORS

A—Circuit suitable for direct frequency-modulation of low-frequency vfo. Capacitor C₁ can be the input capacitance of the modulator tube, or a small trimmer capacitor may be included to permit a variation of the sensitivity of the reactance tube. **B**—An alternative circuit suitable for low-frequency oscillators. The reactance tube is connected across the voltage-divider capacitors of a Clapp oscillator, although the modulator may be used with any common vfo circuit.

grid and ground. However, better control of the operating conditions of the modulator may be had through the use of a variable capacitor as C₃. Resistance R will usually have a value of between 4700 and 100,000 ohms.

An alternative reactance-modulator circuit is shown in figure 7B. The operating conditions are generally the same, except that the r-f excitation voltage to the grid of the reactance tube is obtained effectively through reversing the R and C₃ of figure 7A. In this circuit a small capacitance is used to couple r.f. into the grid of the reactance tube, with a relatively small value of resistance from grid to ground. This circuit has the advantage that the grid of the tube is at relatively low impedance with respect to r.f. However, the circuit normally is not suitable for operation above a few MHz due to the shunting capacitance within the tube from grid to ground.

Either of the reactance-tube circuits may be used with any of the common types of oscillators. The reactance modulator of figure 7A is shown connected to the high-impedance point of a conventional hot-cathode Hartley oscillator, while that of figure 7B is shown connected across the low-impedance capacitors of a series-tuned Clapp oscillator.

Adjusting the Phase Shift One of the simplest methods of adjusting the phase shift to the correct amount is to place a pair of earphones in series with the oscilla-

tor cathode-to-ground circuit and adjust the phase-shift network until minimum sound is heard in the phones when frequency modulation is taking place. If an electron-coupled or Hartley oscillator is used, this method requires that the cathode circuit of the oscillator be inductively or capacitively coupled to the grid circuit, rather than tapped on the grid coil. The phones should be adequately bypassed for radio frequencies.

Stabilization Due to the presence of the reactance-tube frequency modulator, the stabilization of an f-m oscillator in regard to voltage changes is considerably more involved than in the case of a simple self-controlled oscillator for transmitter frequency control. If desired, the oscillator itself may be made perfectly stable under voltage changes, but the presence of the frequency modulator destroys the beneficial effect of any such stabilization. It thus becomes desirable to apply the stabilizing arrangement to the modulator as well as the oscillator.

Reactance-Tube Modulators A simple reactance-tube modulator that may be applied to an existing vfo is illustrated in figure 8. The circuit is extremely simple, yet effective. Only two tubes are used exclusive of the voltage regulator tubes which perhaps may be already

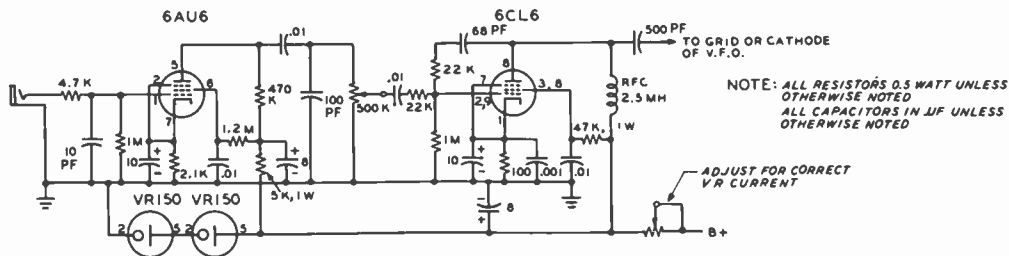

Figure 8

SIMPLE F-M REACTANCE-TUBE MODULATOR

incorporated in the vfo. A 6AU6 serves as a high-gain voltage amplifier stage, and a 6CL6 is used as the reactance modulator since its high value of transconductance will permit a large value of lagging current to be drawn under modulation swing. The unit should be mounted in close proximity to the vfo so that the lead from the 6CL6 to the grid circuit of the oscillator can be as short as possible. A practical solution is to mount the reactance modulator in a small box on the side of the vfo cabinet.

By incorporating speech clipping in the reactance modulator unit, a much more effective use is made of a given amount of deviation. When the f-m signal is received on an a-m receiver by means of slope detection, the use of speech clipping will be noticed by the greatly increased modulation level of the f-m signal, and the attenuation of the center frequency null of no modulation.

Linearity Test It is almost a necessity to run a static test on the reactance-tube frequency modulator to determine its linearity and effectiveness, since small changes in the values of components, and in stray capacitances will almost certainly alter the modulator characteristics. A frequency-versus-control-voltage curve should be plotted to ascertain that equal increments in control voltage, both in a positive and a negative direction, cause equal changes in frequency. If the curve shows that the modulator has an appreciable amount of non-linearity, changes in bias, electrode voltages, r-f excitation, and resistance values may be made to obtain a straight-line characteristic.

Figure 9 shows a method of connecting two 4.5-volt C batteries and a potentiometer to plot the characteristic of the modulator. It will be necessary to use a zero-center voltmeter to measure the grid voltage, or else reverse the voltmeter leads when changing from positive to negative grid voltage. When a straight-line characteristic for the modulator is obtained by the static test method, the capacitances of the various bypass capacitors in the circuit must be kept small to retain this characteristic when an audio voltage is used to vary the frequency in place of the d-c voltage with which the characteristic was plotted.

The Diode Modulator When a resistor and a capacitor are placed in series across an oscillator tank circuit, the current flowing in the series circuit is out of phase with the voltage. If the resistance or capacitance is made variable, the phase difference may be varied. If the variation is controlled at an audio rate, the resultant current can be used to frequency-modulate an oscil-

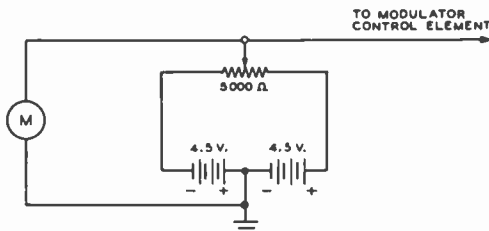

Figure 9

REACTANCE-TUBE LINEARITY CHECKER

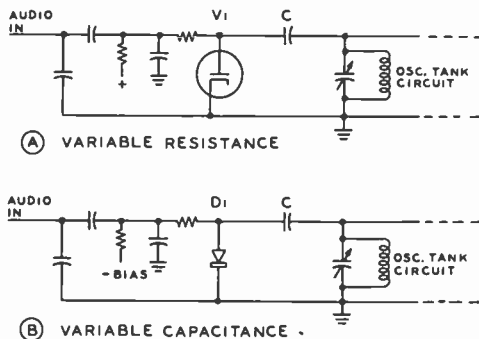

Figure 10

THE DIODE MODULATOR

A—Vacuum diode acts as variable resistance in series with capacitance C to produce phase shift. **B**—Voltage-variable semiconductor D , responds to change in bias level to produce phase shift.

lator (figure 10). The *diode modulator* may be a vacuum tube acting as a variable resistance or a solid-state voltage-variable capacitor whose capacitance varies inversely as the magnitude of the reverse bias. The variable element is placed in series with a small capacitance across the tank circuit of an oscillator to produce a frequency-modulated signal. The bias voltage applied to the diode should be regulated for best results.

14-3 Phase Modulation

By means of *phase modulation* (pm) it is possible to dispense with self-controlled oscillators and to obtain directly crystal-controlled frequency modulation. In the final analysis, phase modulation is simply frequency modulation in which the deviation is directly proportional to the modulation frequency. If an audio signal of 1000 Hz causes a deviation of 0.5 kHz, for example, a 2000-Hz modulating signal of the same amplitude will give a deviation of 1 kHz, and so on. To produce an f-m signal, it is necessary to make the deviation independent of the modulation frequency, and proportional only to the modulating signal. With phase modulation this is done by including a frequency-correcting network in the transmitter. The audio-correction network must have an attenuation that varies directly with frequency, and this requirement is easily met

by a very simple resistance-capacitance network.

The only disadvantage of phase modulation, as compared to direct frequency modulation such as is obtained through the use of a reactance-tube modulator, is the fact that very little frequency deviation is produced directly by the phase modulator. The deviation produced by a phase modulator is independent of the actual carrier frequency on which the modulator operates, but is dependent only on the phase deviation which is being produced and on the modulation frequency. Expressed as an equation:

$$F_d = M_p \text{ modulating frequency}$$

where,

F_d is the frequency deviation one way from the mean value of the carrier,

M_p is the phase deviation accompanying modulation expressed in radians (a radian is approximately 57.3°).

Thus, to take an example, if the phase deviation is $\frac{1}{2}$ radian and the modulating frequency is 1000 Hz, the frequency deviation applied to the carrier being passed through the phase modulator will be 500 Hz.

It is easy to see that an enormous amount of multiplication of the carrier frequency is required in order to obtain from a phase modulator the frequency deviation of 75 kHz required for commercial f-m broadcasting. However, for amateur and commercial narrow-band f-m work (nbfm) only a quite reasonable number of multiplier stages are required to obtain a deviation ratio of approximately one.

Many vhf f-m transmitters employ crystal control with the crystal frequency one twenty-fourth or one thirty-second of the carrier frequency. A deviation of 15 kHz at 144 MHz, for example, is equivalent to a deviation of 0.625 kHz at a crystal frequency of 6 MHz, which is well within the linear capability of a phase modulator. Some high-frequency f-m gear for the 30-MHz region employs crystals in the 200- to 500-kHz region to achieve sufficient frequency multiplication for satisfactory phase modulation at the crystal frequency.

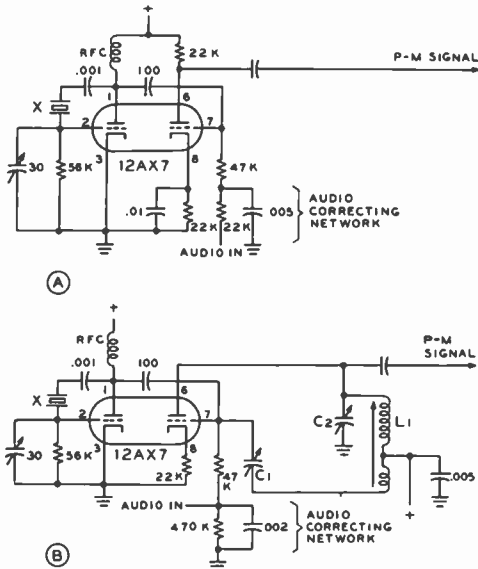

Figure 11

PHASE-MODULATION CIRCUITS

A—Basic phase modulator utilizing RC network, with the resistance arm replaced by the variable plate resistance of the vacuum tube. **B**—Capacitor C_1 provides adjustment for the phase of the r-f voltage acting between grid and plate of the phase modulator. Capacitor C_2 serves as phase and magnitude control. Both capacitors are adjusted for maximum phase-modulation capability of the circuit.

Odd-harmonic distortion is produced when frequency-modulation is obtained by the phase-modulation method, and the amount of this distortion that can be tolerated is the limiting factor in determining the amount of phase modulation that can be used. Since the aforementioned frequency-correcting network causes the lowest modulating frequency to have the greatest amplitude, maximum phase modulation takes place at the lowest modulating frequency, and the amount of distortion that can be tolerated at this frequency determines the maximum deviation that can be obtained by the p-m method. For high-fidelity broadcasting, the deviation produced by phase modulation is limited to an amount equal to about one-third of the lowest modulating frequency. But for nbfm work the deviation may be as high as 0.6 of the modulating frequency before distortion becomes objectionable on voice modulation. In other terms this means that phase

deviations as high as 0.6 radian may be used for amateur and commercial nbfm transmission.

The Phase Modulator A change in the phase of a signal can be produced by passing the signal through a network containing a resistance and a reactance. If the series combination is considered to be the input, and the output voltage is taken from across the resistor, a definite amount of phase shift is introduced, the amount depending on the frequency of the signal and the ratio of the reactance to the resistance. When the resistance is varied with an applied audio signal, the phase angle of the output changes in direct proportion to the audio signal amplitude and produces a phase-modulated signal.

Two practical phase modulators are shown in figure 11. Circuit A is the basic resistance and capacitance phase-shift network with the resistance replaced by the variable plate resistance of a vacuum tube. The plate resistance of the second section of the 12AX7 changes with grid voltage and therefore serves as the variable resistor element. As the plate resistance of the triode changes with the audio signal applied to the grid circuit, the phase between the input of the circuit and the output changes in accord with the audio signal. A variation of this circuit, one in which the transconductance changes with varying input signal, is often used as the basis for a p-m signal.

Circuit B is also suitable for phase modulation. Capacitor C_1 of the second section of the 12AX7 should not be thought of as a neutralizing capacitor, but rather as an adjustment for the phase of the r-f voltage acting between the grid and plate of the phase modulator. Capacitor C_2 acts as a phase-angle and magnitude control, and both capacitors should be adjusted for maximum phase-modulation capability of the circuit. Resonance is established by tuning the slug of coil L_1 . This circuit has about six times the deviation capability of the circuit of illustration A.

Measurement of Deviation When a single-frequency modulating voltage is used with an f-m transmitter the relative amplitudes of the various sidebands and

the carrier vary widely as the deviation is varied by increasing or decreasing the amount of modulation. Since the relationship between the amplitudes of the various sidebands and carrier to the audio modulating frequency and the deviation is known, a simple method of measuring the deviation of a frequency-modulated transmitter is possible. In making the measurement, the result is given in the form of the modulation index for a certain amount of audio input. As previously described, the modulation index is the frequency of the audio modulation.

The measurement is made by applying a sine-wave audio voltage of known frequency to the transmitter, and increasing the modulation until the amplitude of the carrier component of the frequency-modulated wave reaches zero. The modulation index for zero carrier may then be determined from the table below. As may be seen from the table, the first point of zero carrier is obtained when the modulation index has a value of 2.405—in other words, when the deviation is 2.405 times the modulation frequency. For example, if a modulation frequency of 1000 Hz is used, and the modulation is increased until the first carrier null is obtained, the deviation will then be 2.405 times the modulation frequency, or 2.405 kHz. If the modulating frequency happened to be 2000 Hz, the deviation at the first null would be 4.810 kHz. Other carrier nulls will be obtained when the index is 5.52, 8.654, and at increasing values separated approximately by π . The following is a listing of the modulation index at successive carrier nulls up to the tenth:

Zero carrier point no.	Modulation index
1	2.405
2	5.520
3	8.654
4	11.792
5	14.931
6	18.071
7	21.212
8	24.353
9	27.494
10	30.635

The only equipment required for making the measurements is a calibrated audio oscillator of good wave form, and a communication receiver equipped with a beat oscillator and crystal filter. The receiver should be used with its crystal filter set for minimum bandwidth to exclude sidebands spaced from the carrier by the modulation frequency. The unmodulated carrier is accurately tuned on the receiver with the beat oscillator operating. Then modulation from the audio oscillator is applied to the transmitter, and the modulation is increased until the first carrier null is obtained. This carrier null will correspond to a modulation index of 2.405, as previously mentioned. Successive null points will correspond to the indices listed in the table.

A volume indicator in the transmitter audio system may be used to measure the audio level required for different amounts of deviation, and the indicator thus calibrated in terms of frequency deviation. If the measurements are made at the fundamental frequency of the oscillator, it will be necessary to multiply the frequency deviation by the harmonic upon which the transmitter is operating, of course. It will probably be most convenient to make the determination at some frequency intermediate between that of the oscillator and that at which the trans-

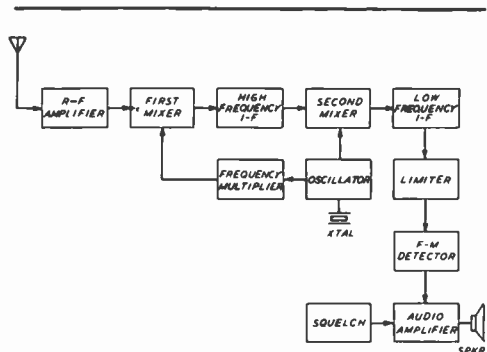

Figure 12
DOUBLE-CONVERSION RECEIVER
FOR VHF F-M RECEPTION

Most vhf f-m receivers are of the double-conversion type, many of which use a single crystal for both the first and second frequency-converter stages. Modern commercial receivers employ a frequency synthesizer to generate the proper mixing frequencies, permitting the reception on a large number of channels with the use of few mixing crystals.

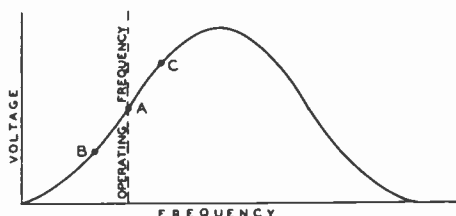

Figure 13

SLOPE DETECTION OF F-M SIGNAL

One side of the response characteristic of a tuned circuit or of an i-f amplifier may be used as shown to convert frequency variations of an incoming signal into amplitude variations.

mitter is operating, and then to multiply the result by the frequency multiplication between that frequency and the transmitter output frequency.

14-4 Reception of F-M Signals

A conventional communications receiver may be used to receive narrow-band f-m transmission, although performance will be much poorer than can be obtained with an nbfm receiver or adapter. However, a receiver specifically designed for f-m reception must be used when it is desired to receive high deviation f-m such as used by f-m broadcast stations, TV sound, and mobile communications.

The f-m receiver must have, first of all, a bandwidth sufficient to pass the range of frequencies generated by the f-m transmitter. And since the receiver must be superheterodyne if it is to have good sensitivity at the frequencies to which frequency modulation is restricted, i-f bandwidth is an important factor in its design.

The second requirement of the f-m receiver is that it incorporate some sort of device for converting frequency changes into amplitude changes, in other words, a detector operating on frequency variations rather than amplitude variations. Most f-m equipment operates in the vhf region, and at these frequencies it is not always possible to obtain optimum performance at reasonable cost with a single-conversion superheterodyne receiver. When good adjacent-

channel selectivity is necessary, a low i-f channel is desirable; this, however, lowers the image rejection ability of the receiver. Similarly, if good image rejection is desired, a high i-f channel should be used, but this is not compatible with good adjacent-channel rejection unless an expensive i-f filter is employed.

These difficulties are compromised by the use of a double-conversion receiver, such as the one shown in the block diagram of figure 12. In many receiver designs, the high i-f channel is chosen so that a harmonic of the mixing oscillator used for the second mixer may be used with the first mixer to reduce the number of crystals in the receiver. In other cases, a frequency synthesizer is used to generate the proper mixing frequencies.

The third requirement, and one which is necessary if the full noise-reducing capabilities of the f-m system of transmission are desired, is a limiting device to eliminate amplitude variations before they reach the detector. A block diagram of the essential parts of an f-m receiver is shown in figure 12.

The Frequency Detector The simplest device for converting frequency variations to amplitude variations is an "off-tune" resonant circuit, as illustrated in figure 13. With the carrier tuned in at point A, a certain amount of r-f voltage will be developed across the tuned circuit, and, as the frequency is varied either side of this frequency by the modulation, the r-f voltage will increase and decrease to point C and B in accordance with the modulation. If the voltage across the tuned circuit is applied to an ordinary detector, the detector output will vary in accordance with the modulation, the amplitude of the variation being proportional to the deviation of the signal, and the rate being equal to the modulation frequency. It is obvious from figure 13 that only a small portion of the resonance curve is usable for linear conversion of frequency variations into amplitude variations, since the linear portion of the curve is rather short. Any frequency variation which exceeds the linear portion will cause distortion of the recovered audio. It is also obvious by inspection of figure 13 that an a-m receiver

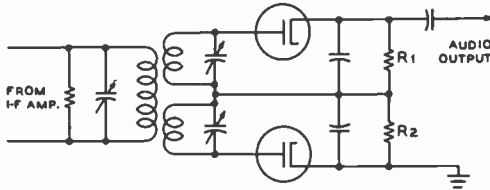

Figure 14

TRAVIS DISCRIMINATOR

This type of discriminator makes use of two off-tuned resonant circuits coupled to a single primary winding. The circuit is capable of excellent linearity, but is difficult to align.

used in this manner is vulnerable to signals on the peak of the resonance curve and also to signals on the other side of the resonance curve. Further, no noise-limiting action is afforded by this type of reception. This system, therefore, is not recommended for f-m reception, although it may be widely used by amateurs for occasional nbfm reception.

Travis Discriminator Another form of frequency detector or *discriminator*, is shown in figure 14. In this arrangement two tuned circuits are used, one tuned on each side of the i-f amplifier frequency, and with their resonant frequencies spaced slightly more than the expected transmitter swing. Their outputs are combined in a differential rectifier so that the voltage across series load resistors R_1 and R_2 is equal to the algebraic sum of the individual output voltages of each rectifier. When a signal at the i-f midfrequency is received, the voltages across the load resistors are equal and opposite, and the sum voltage is zero. As the r-f signal varies from the midfrequency, however, these individual voltages become unequal, and a voltage having the polarity of the larger voltage and equal to the difference between the two voltages appears across the series resistors, and is applied to the audio amplifier. The relationship between frequency and discriminator output voltage is shown in figure 15. The separation of the discriminator peaks and the linearity of the output voltage-versus-frequency curve depend on the discriminator frequency, the Q of the tuned circuits, and the value of the diode load resistors. As the intermediate (and discriminator) frequency is increased, the peaks must be separated

As its "center" frequency the discriminator produces zero output voltage. On either side of this frequency it gives a voltage of a polarity and magnitude which depend on the direction and amount of frequency shift.

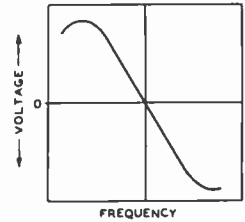

Figure 15

DISCRIMINATOR VOLTAGE-FREQUENCY CURVE

further to secure good linearity and output. Within limits, as the diode load resistance or the Q is reduced, the linearity improves, and the separation between the peaks must be greater.

Foster-Seeley Discriminator The most widely used form of discriminator is that shown in figure 16. This type of discriminator yields an output voltage-versus-frequency characteristic similar to that shown in figure 17. Here, again, the output voltage is equal to the algebraic sum of the voltages developed across the load resistors of the two diodes, the resistors being connected in series to ground. However, this *Foster-Seeley* discriminator requires only two tuned circuits instead of the three used in the previous discriminator. The operation of the circuit results from the phase relationships existing in a transformer having a tuned secondary. In effect, as a close examination of the circuit will reveal, the primary circuit is in series for r.f. with each half of the secondary to ground. When the received signal is at the resonant frequency of the secondary, the r-f voltage across the secondary is 90 degrees out of phase with that across the primary. Since each diode is connected across one half of the secondary winding and the primary winding in series, the resultant r-f voltages applied to each are equal, and the voltages developed across each diode load resistor are equal and of opposite polarity. Hence, the net voltage between the top of the load resistors and ground is zero. This is shown vectorially in figure 17A where the resultant voltages R and R' which are applied to the two diodes are shown to be equal when the phase angle between pri-

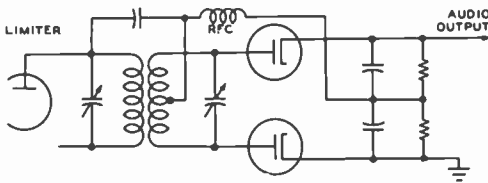

Figure 16

FOSTER-SEELEY DISCRIMINATOR

This discriminator is the most widely used circuit since it is capable of excellent linearity and is relatively simple to align when proper test equipment is available.

primary and secondary voltages is 90 degrees. If, however, the signal varies from the resonant frequency, the 90-degree phase relationship no longer exists between primary and secondary.

The result of this effect is shown in figure 17B where the secondary r-f voltage is no longer 90 degrees out of phase with respect to the primary voltage. The resultant voltages applied to the two diodes are now no longer equal, and a d-c voltage proportional to the difference between the r-f voltages applied to the two diodes will exist across the series load resistors. As the signal frequency varies back and forth across the resonant frequency of the discriminator, an a-c voltage of the same frequency as the original modulation, and proportional to the deviation, is developed and passed on to the audio amplifier.

Ratio One of the more recent types of **Detector** f-m detector circuits, called the *ratio detector* is diagrammed in figure 18. The input transformer can be designed so that the parallel input voltage to the diodes can be taken from a tap on the primary of the transformer, or this voltage may be obtained from a tertiary winding coupled to the primary. The r-f choke used must have high impedance at the intermediate frequency used in the receiver, although this choke is not needed if the transformer has a tertiary winding.

The circuit of the ratio detector appears very similar to that of the more conventional discriminator arrangement. However, it will be noted that the two diodes in the ratio detector are polarized so that their d-c output voltages add, as contrasted to the

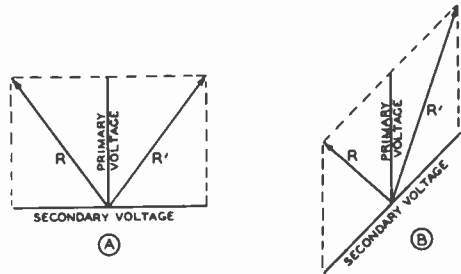

Figure 17

DISCRIMINATOR VECTOR DIAGRAM

A signal at the resonant frequency of the secondary will cause the secondary voltage to be 90 degrees out of phase with the primary voltage, as shown at A, and the resultant voltages R and R' are equal. If the signal frequency changes, the phase relationship also changes, and the resultant voltages are no longer equal, as shown at B. A differential rectifier is used to give an output voltage proportional to the difference between R and R' .

Foster-Seeley circuit wherein the diodes are polarized so that the d-c output voltages buck each other. At the center frequency to which the discriminator transformer is tuned, the voltage appearing at the top of the 1-megohm potentiometer will be one-half the d-c voltage appearing at the *avc output* terminal, since the contribution of each diode will be the same. However, as the input frequency varies to one side or the other of the tuned value (while remaining within the

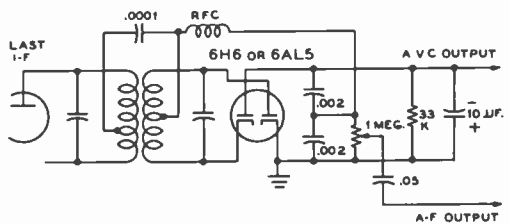

Figure 18

RATIO-DETECTOR CIRCUIT

The parallel voltage to the diodes in a ratio detector may be obtained from a tap on the primary winding of the transformer or from a third winding. Note that one of the diodes is reversed from the system used with the Foster-Seeley discriminator, and that the output circuit is completely different. The ratio detector does not have to be preceded by a limiter, but is more difficult to align for distortion-free output than the conventional discriminator.

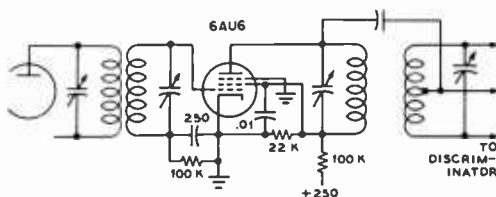

Figure 19

LIMITER CIRCUIT

One, or sometimes two, limiter stages normally precede the discriminator so that a constant signal level will be fed to the f-m detector. This procedure eliminates amplitude variations in the signal fed to the discriminator, so that it will respond only to frequency changes.

passband of the i-f amplifier feeding the detector) the relative contributions of the two diodes will be different. The voltage appearing at the top of the 1-megohm volume control will increase for frequency deviations in one direction and will decrease for frequency deviations in the other direction from the mean or tuned value of the transformer. The audio output voltage is equal to the ratio of the relative contributions of the two diodes, hence the name ratio detector.

The ratio detector offers several advantages over the simple discriminator circuit. The circuit does not require the use of a limiter preceding the detector since the circuit is inherently insensitive to amplitude modulation on an incoming signal. This factor alone means that the r-f and i-f gain ahead of the detector can be much less than the conventional discriminator for the same over-all sensitivity. Further, the circuit provides avc voltage for controlling the gain of the preceding r-f and i-f stages. The ratio detector is, however, susceptible to variations in the amplitude of the incoming signal as in any other detector circuit except the discriminator *with* a limiter preceding it, so that avc should be used on the stage preceding the detector.

Limiters The limiter of an f-m receiver using a conventional discriminator serves to remove amplitude modulation and pass on to the discriminator a frequency-modulated signal of constant amplitude; a typical circuit is shown in figure 19. The limiter tube is operated as an i-f stage with

very low plate voltage and with grid-resistor bias, so that it overloads quite easily. Up to a certain point the output of the limiter will increase with an increase in signal. Above this point, however, the limiter becomes overloaded, and further large increases in signal will not give any increase in output. To operate successfully, the limiter must be supplied with a large amount of signal, so that the amplitude of its output will not change for rather wide variations in amplitude of the signal. Noise, which causes little frequency modulation but much amplitude modulation of the received signal, is virtually wiped out in the limiter.

The voltage across the grid resistor varies with the amplitude of the received signal. For this reason, conventional amplitude-modulated signals may be received on the f-m receiver by connecting the input of the audio amplifier to the top of this resistor, rather than to the discriminator output. When properly filtered by a simple RC circuit, the voltage across the grid resistor may also be used as avc voltage for the receiver. When the limiter is operating properly avc is neither necessary nor desirable, however, for f-m reception alone.

Receiver Design Considerations One of the most important factors in the design of an f-m receiver is the frequency swing which it is intended to handle. It will be apparent from figure 15 that if the straight portion of the discriminator circuit covers a wider range of frequencies than those generated by the transmitter, the audio output will be reduced from the maximum value of which the receiver is capable.

In this respect, the term *modulation percentage* is more applicable to the f-m receiver than it is to the transmitter, since the modulation capability of the communication system is limited by the receiver bandwidth and the discriminator characteristic; full utilization of the linear portion of the characteristic amounts, in effect, to 100 percent modulation. This means that some sort of standard must be agreed on, for any particular type of communication, to make it unnecessary to vary the transmitter swing to accommodate different receivers.

Two considerations influence the receiver bandwidth necessary for any particular type

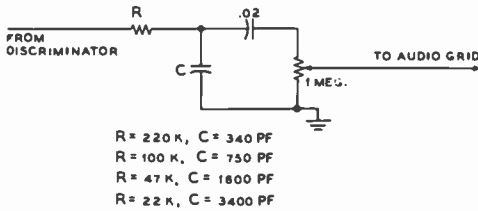

Figure 20

75-MICROSECOND DE-EMPHASIS CIRCUIT

The audio signal transmitted by f-m and TV stations has received high-frequency pre-emphasis, so that a de-emphasis circuit should be included between the output of the f-m detector and the input of the audio system.

of communication. These are the maximum audio frequency which the system will handle, and the deviation ratio which will be employed. For voice communication, the maximum audio frequency is more or less fixed at 3000 to 4000 Hz. In the matter of deviation ratio, however, the amount of noise suppression which the f-m system will provide is influenced by the ratio chosen, since the improvement in signal-to-noise ratio which the f-m system shows over amplitude modulation is equivalent to a constant multiplied by the deviation ratio. This assumes that the signal is somewhat stronger than the noise at the receiver, however, as the advantages of wideband frequency modulation in regard to noise suppression disappear when the signal-to-noise ratio approaches unity.

On the other hand, a low deviation ratio is more satisfactory for strictly communication work, where readability at low signal-to-noise ratios is more important than additional noise suppression when the signal is already appreciably stronger than the noise.

As mentioned previously, broadcast f-m practice is to use a deviation ratio of 5. When this ratio is applied to a voice-communication system, the total swing becomes 30 to 40 kHz. With lower deviation ratios, such as are most frequently used for voice work, the swing becomes proportionally less, until at a deviation ratio of 1 the swing is equal to twice the highest audio frequency. Actually, however, the receiver bandwidth must be slightly greater than the expected transmitter swing, since for distortionless reception the receiver must pass the complete band of energy generated by the transmitter, and this band will always cover a range somewhat wider than the transmitter swing.

Pre-Emphasis and De-Emphasis Standards in f-m broadcast and TV sound work call for the pre-emphasis of all audio modulating frequencies above about 2000 Hz, with a rising slope such as would be produced by a 75-microsecond RL network. Thus the f-m receiver should include a compensating de-emphasis RC network with a time constant of 75 microseconds so that the over-all frequency response from microphone to speaker will approach linearity. The use of pre-emphasis and de-emphasis in this manner results in a considerable im-

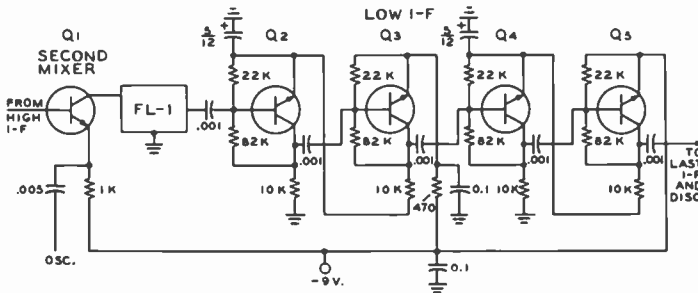

Figure 21

TRANSISTOR I-F STRIP USES CASCODE CIRCUIT

Transistors in pairs (Q₂-Q₃ and Q₄-Q₅) are placed in series in regard to the supply voltage in the manner of a cascode amplifier so that each transistor of a pair has half the d-c voltage across it. A crystal or mechanical filter provides good adjacent-channel selectivity.

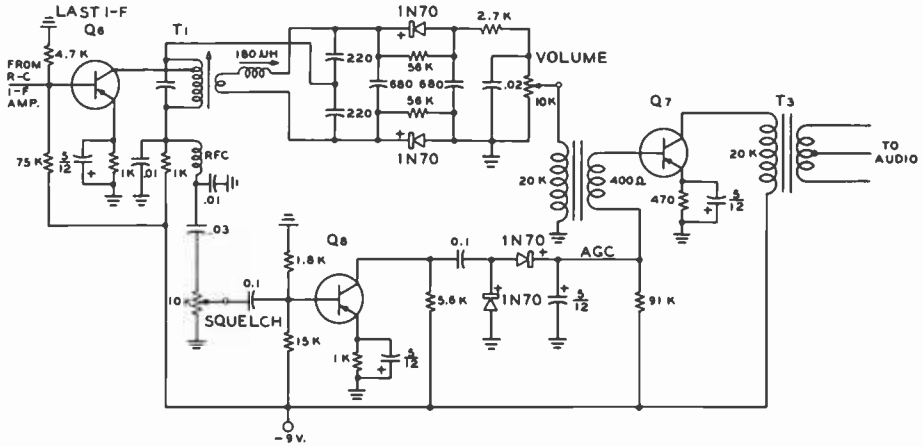

Figure 22

F-M DETECTOR, SQUELCH, AND AGC CIRCUIT

Squelch voltage is derived from the last i-f stage, amplified and rectified, and applied as a control voltage to the base of first audio-amplifier transistor, Q₇.

provement in the over-all signal-to-noise ratio of an f-m system. Appropriate values for the de-emphasis network, for different values of circuit impedance are given in figure 20.

F-M Receiver Circuitry F-m receivers, as with receivers for other modes, exhibit interesting circuits that are unique to the service. Shown in figure 21 is a transistorized low frequency i-f strip used in many compact f-m receivers and transceivers. A filter package (FL-1) provides adjacent-channel selectivity and i-f gain is achieved in a resistance-capacitance coupled four-stage amplifier. The stages are paired

in regard to the supply voltage, with the paired transistors placed in series so that each has half the supply voltage, somewhat in the manner of a cascode amplifier. The whole i-f strip may be built on a printed-circuit board somewhat larger than a postage stamp. Type 2N291 transistors may be used in this design.

A companion transistor f-m detector, audio squelch, and agc circuit are shown in figure 22. These stages may also be assembled on a printed-circuit board, along with a suitable audio amplifier for speaker operation.

A NBFM 455-kHz Adapter Unit The unit diagrammed in figure 23 is designed to provide nbfm reception when attached to any communication receiver having a 455-kHz i-f amplifier. Although nbfm can be received on an a-m receiver by tuning the receiver to one side or the other of the incoming signal, a tremendous improvement in signal-to-noise ratio and in signal to amplitude ratio will be obtained by the use of a true f-m detector system.

The adapter uses two tubes. A 6AU6 is used as a limiter, and a 6AL5 as a discriminator. The audio level is approximately 10 volts peak for the maximum deviation which

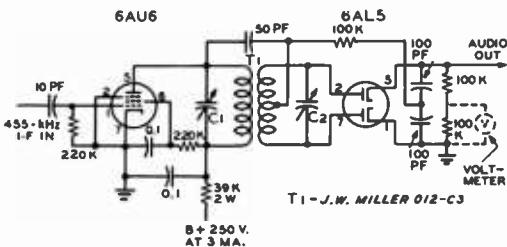

NOTE: ALL CAPACITORS IN I-F UNLESS OTHERWISE NOTED
ALL RESISTORS 0.5 WATT UNLESS OTHERWISE NOTED

Figure 23

NBFM ADAPTER FOR 455-kHz I-F SYSTEM

can be handled by a conventional 455-kHz i-f system. The unit may be tuned by placing a high resistance d-c voltmeter across R_1 and tuning the trimmers of the i-f transformer for maximum voltage when an unmodulated signal is injected into the i-f strip of the receiver. The voltmeter should next be connected across the audio output terminal of the discriminator. The receiver is now tuned back and forth across the frequency of the incoming signal, and the movement of the voltmeter noted. When the receiver is exactly tuned on the signal the voltmeter reading should be zero. When the receiver is tuned to one side of center, the voltmeter reading should increase to a maximum value and then decrease gradually to zero as the signal is tuned out of the passband of the receiver. When the receiver is tuned to the other side of the signal the voltmeter should increase to the same maximum value but in the opposite direction or polarity, and then fall to zero as the signal is tuned out of the passband. It may be necessary to make small adjustments to C_1 and C_2 to make the voltmeter read zero when the signal is tuned in the center of the passband.

F-M Mobile Relays Since radio transmission in the vhf region is essentially short range, a form of radio relay station termed a *repeater* may be employed to expand the communication range of base or mobile stations over an extended distance. Various types of relays are in use in the United States, their operation depending on the requirements of the communications circuit.

The *relay unit* is a fixed repeating station whose specific purpose is to extend station-to-station communication capability. The user's transmitter is on the input frequency while his receiver is on the output frequency of the relay (figure 24). When desired, direct communication between stations may take place by using a closely spaced frequency domain and a two-frequency transmitter.

The *remote base* is a form of relay unit whose location has a height or tactical advantage. Means must be provided to control such an installation which in amateur service most often is working in conjunction with a pair of frequencies—input and out-

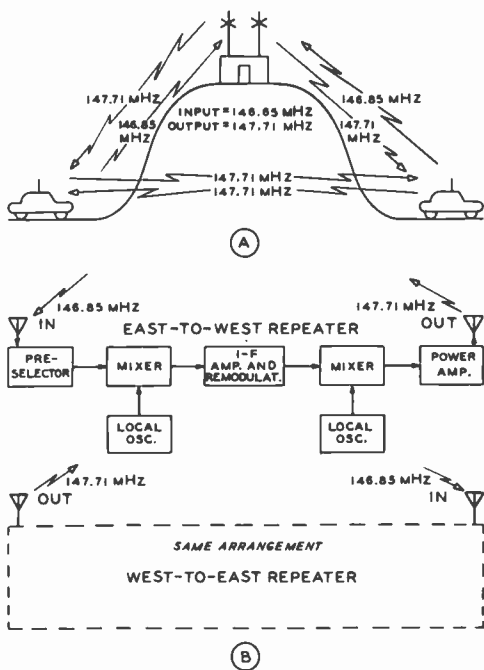

Figure 24

F-M Remote Repeater for Mobile Service

Radio relay station serves as a repeater to extend the range of base or mobile f-m stations. Communication between units may be achieved either directly, or through repeater. The repeater consists of a back-to-back receiver and transmitter having a common i-f and remodulator system. Most repeaters are limited to a single channel, but multiplex operation permits simultaneous transmission of different information forms on the channel.

put. In so doing, remote bases serve on common frequencies by which individual groups operating their own installation can cross-communicate. Frequencies above 220 MHz or direct-wire lines must be used for remote control.

Simplex communication, on the other hand, refers to communication between individual units operating on a common transmit and receive frequency. Thus simplex operation can be interfaced with relay operation, using either a local or remote base. Remote base operation must take place under FCC license to a responsible controlling authority and each application for such service is judged individually on the merits of the case.

While most repeaters are limited to a single communication channel, *multiplex* operation, or simultaneous transmission of two or more signals on a common carrier wave is often employed by means of narrow-band filter techniques. For example, simultaneous voice and RTTY transmissions may occur on a single channel. It is also possible to insert traffic at a relay station for transmission in either or both directions and, in addition, *duplex* (two way simultaneous) transmission through the relay may be achieved in many cases.

The performance of the f-m repeater may be degraded by the broad spectrum of *white noise* generated by the low-Q circuits of the transmitter, the broad noise spectrum masking weak signals on the receive frequency, causing the repeater receiver to be less sensitive with the repeater transmitter on than it is when the transmitter is off. This desensitization can result in repeater "pumping," the transmitter coming on and generating noise that causes the repeater

receiver to lose the incoming signal and thus turning the transmitter off. As soon as the transmitter is off, the receiver again detects the incoming signal and the cycle is repeated. Sufficient separation between receiving and transmitting antennas at the repeater site and the addition of high-Q intermediate tuned circuits in the transmitter will be of benefit in increasing coupling loss between input and output circuits of the repeater. In addition, the SWR on both receiving and transmitting feedlines to the respective antennas must be low. When the SWR is high, the feedlines become part of the radiating antenna, and since the feedlines often run parallel to each other, the coupling loss between antennas may be degraded.

It is beyond the scope of this handbook to cover f-m repeaters in detail. Extensive coverage on this subject can be found in the "F-M Repeater Handbook" published by Editors and Engineers, New Augusta, Indiana.

Radioteletype Systems

Teleprinting is a form of intelligence based on a simple binary (on-off) code designed for electromechanical transmission. The code consists of d-c pulses generated by a special electric typewriter, which can be reproduced at a distance by a separate machine. The pulses may be transmitted from one machine to another by wire or by a radio circuit. When radio transmission is used, the system is termed *radioteletype* (RTTY). The name *teletype* is a registered trademark of *Teletype Corporation* and the term *teleprinter* is used in preference to the registered term.

15-1 Radioteletype Systems

The d-c pulses that comprise the teleprinter signal may be converted into three basic forms of emission suitable for radio transmission. These are: (1) *frequency-shift keying* (FSK), designated as F1 emission; (2) *make-break keying* (MBK), designated as A1 emission; and (3) *audio frequency-shift keying* (AFSK), designated as F2 emission.

Frequency-shift keying is achieved by varying the transmitted frequency of the radio signal a fixed amount (usually 850 Hertz or less) during the keying process. The shift is accomplished in discrete intervals designated *mark* and *space*. Both types of intervals convey information to the teleprinter. *Make-break keying* is analogous to simple c-w transmission in that the radio carrier

conveys information by changing from an *on* to an *off* condition. Early RTTY circuits employed MBK equipment, which is now considered obsolete since it is less reliable than the frequency-shift technique. *Audio frequency-shift keying* employs a steady radio carrier modulated by an audio tone which is shifted in frequency according to the RTTY pulses. Other forms of information transmission may be employed by a RTTY system which also encompass translation of binary pulses into r-f signals.

The Teleprinter Code The teleprinter code consists of 26 letters of the alphabet and additional characters that accomplish machine functions, such as line feed, carriage return, bell, and upper- and lower-case shift. These special characters are required for the complete automatic process of teleprinter operation in printing received copy. Numerals, punctuation, and symbols may be taken care of in the case shift, since all transmitted letters are capitals.

The teleprinter code is made up of spaces and pulses, each of 22 milliseconds duration for radio amateur transmission at 60 words per minute. Each character is made up of five elements, plus a 22 millisecond *start space* and a 31 millisecond *stop pulse*. All characters are equal in total transmission time to 163 milliseconds duration to achieve machine synchronization at both ends of the RTTY circuit. Timing is usually accomplished by the use of synchronous motors in

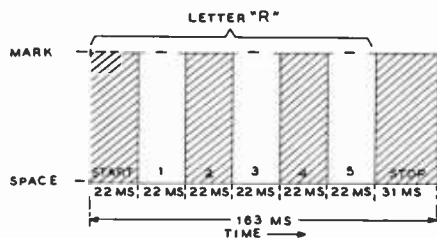

Figure 1

THE TELEPRINTER CODE

Teleprinting is based on a simple binary code made up of spaces and pulses, each of 22 milliseconds duration. Normal transmission is at the rate of 60 w.p.m. The sequence of mark and space pulses for the letter R are shown here. Start space provides time for machine synchronization and stop pulse provides time for sending and receiving mechanisms to position themselves for transmission of the following character.

the equipment, locked to the a-c line frequency. The sequence of mark and space pulses for the letter R is shown in figure 1. The start space provides time for synchronization of the receiving machine with the sending machine. The stop pulse provides time for the sending mechanism as well as the receiving mechanism to properly position themselves for transmission of the following character.

The FSK system normally employs the higher radio frequency as the mark and the lower frequency as the space. This relationship often holds true in the AFSK system also. The lower audio frequency may be 2125 Hz and the higher audio frequency 2975 Hz, giving a frequency difference or shift of 850 Hz. Other, more narrow shifts are gradually coming into popularity in radio amateur RTTY work.

The Teleprinter The teleprinter resembles a typewriter in appearance, having a keyboard, a type basket, a carriage, and other familiar appurtenances. The keyboard, however, is not mechanically linked to the type basket or printer. When a key is pressed on the keyboard of the sending apparatus a whole code sequence for that character is generated in the form of pulses and spaces. When this code sequence is received on a remote machine, a type bar is selected

and made to print the letter corresponding to the key pressed. Synchronization of machines is accomplished by means of start and stop pulses transmitted with each character. An electromechanical device driven by the motor of the teleprinter is released when a key is pressed and transmission of the complete character is automatic.

The receiving apparatus operates in reverse sequence, being set in operation by the first pulse of a character sent by the transmitter mechanism. While each character is sent at the speed of 60 w.p.m., actual transmission of a sequence of characters may be much slower, depending on the speed of the operator. A simplified diagram of a one-way RTTY circuit is shown in figure 2.

15-2 RTTY Reception

The RTTY receiving mechanism must respond to a sequence of pulses and spaces transmitted by wire or radio. Frequency-shift keying may be demodulated by a beat-frequency technique, or by means of a discriminator as employed in f-m service. The received signal is converted into d-c pulses which are used to operate the printing magnets in the teleprinter. Conversion of RTTY signals into proper pulses is accomplished by a *receiving converter (terminal unit, abbreviated TU)*. RTTY converters may be either i-f

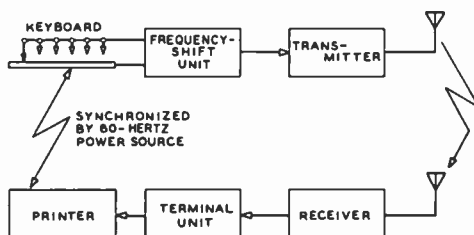

Figure 2

BLOCK DIAGRAM OF ONE-WAY-RTTY CIRCUIT

The teleprinter generates code sequence in the form of on-off pulses for the alphabet and additional special characters. Teleprinter code is transmitted at rate of 60 w.p.m. by means of frequency-shift technique. The receiving apparatus drives a mechanical printer that is usually synchronized with the keyboard by the common 60-Hz power source.

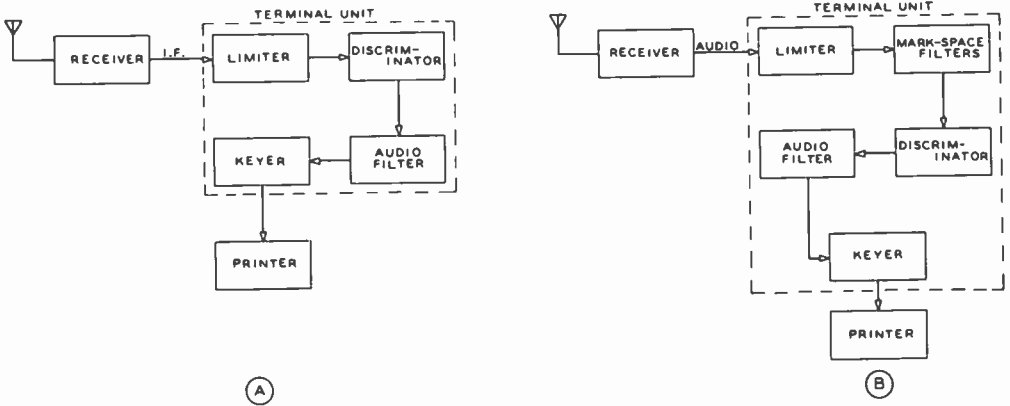

Figure 3

A shows block diagram of i-f terminal unit employing f-m discriminator technique. I-f converter requires that selectivity and interference rejection be achieved by means of selective tuned circuits of the receiver. B shows block diagram of audio-frequency terminal unit. Mark and space filters are used ahead of audio discriminator, followed by a low-pass audio filter. Beat oscillator of receiver is used to provide audio beat tones of 2125 and 2975 Hz required for nominal 850-Hz shift system.

discriminator or audio discriminator units. A block diagram of an intermediate-frequency converter is shown in figure 3A. The RTTY signal in the i-f system of the receiver is considered to be a carrier frequency-modulated by a 22.8-Hz square wave having a deviation of plus and minus 425 Hz (for 850-Hz shift). Amplitude variations are removed by the limiter stage and the discriminator stage converts the frequency shift into a 22.8-Hz waveform, applied to the teleprinter by means of an electronic

keyer. In its simplest form, the i-f converter requires that adequate selectivity and interference rejection be achieved by means of the i-f system of the receiver.

The schematic of a typical i-f RTTY converter is shown in figure 4.

A block diagram of an audio-frequency converter is shown in figure 3B. An audio limiter is followed by mark-frequency and space-frequency filters placed ahead of the discriminator stage. A low-pass filter and electronic keyer provide the proper d-c sig-

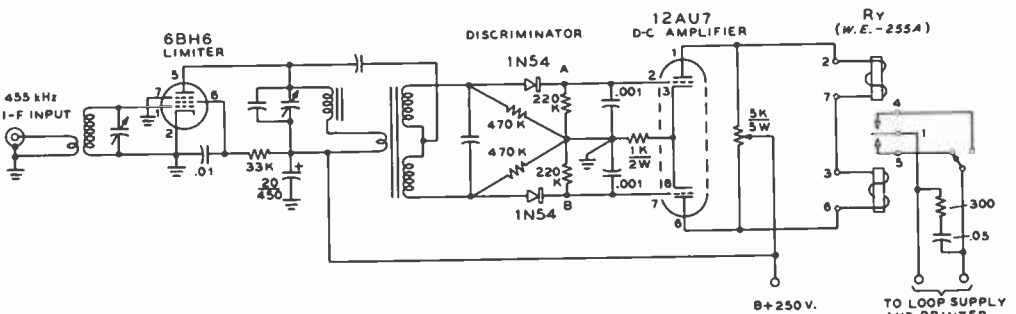

Figure 4

I-F RTTY CONVERTER

Typical i-f converter circuit illustrates this technique. Some type of indication that the RTTY signal is properly tuned is required, particularly on the hf bands. With the i-f terminal unit, a zero-center microammeter may be connected across discriminator load resistors (A-B).

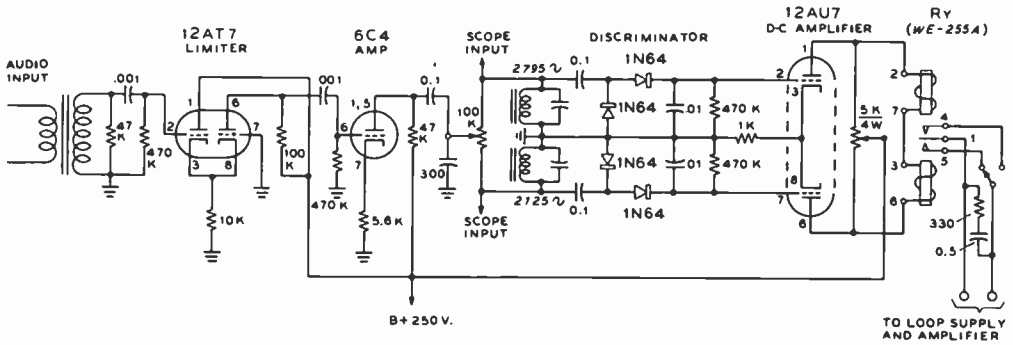

Figure 5

AUDIO RTTY CONVERTER

The audio terminal unit usually has an oscilloscope presentation in the form of a cross, with the horizontal input for "mark" and the vertical input for "space."

nal required by the teleprinter. The beat oscillator of the receiver is used to provide the beat tones of 2125 and 2975 Hz required in the usual 850-Hz shift system. Either frequency may be used for either mark or space, and the signals may be easily inverted by tuning the beat oscillator to the opposite side of the i-f passband of the receiver. The schematic of a simple audio-frequency RTTY converter is shown in figure 5.

Receiving converters of both types usually include clipping and limiting stages which hold the signal at constant amplitude and converters occasionally include pulse-forming circuits which help to overcome distortion that occurs during transmission of the intelligence.

Teleprinters are actuated by electromagnets which release the motor-driven mechanism driving the type bars. The magnets require 20 or 60 milliamperes of current which may be obtained from an electronic keyer such as the one shown in figure 6. A single teleprinter may be run as an electric typewriter on a *local loop supply* which couples the keyboard and typing mechanisms in a single circuit (figure 7).

15-3 Frequency-Shift Keying

The keyed d-c voltage from the teleprinter is used to operate a keyer circuit to shift the transmitter carrier back and forth in frequency in accord with the mark and

space intelligence of the RTTY code. Frequency-shift keying (FSK) may be accomplished by varying the frequency of the transmitter oscillator in a stable manner between two chosen frequencies. The amount of shift must be held within close tolerances as the shift must match the frequency difference between the selective filters in the receiving terminal unit. The degree of fre-

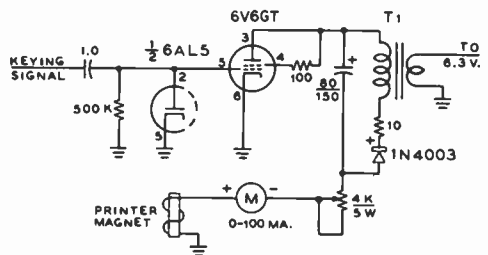

Figure 6

ELECTRONIC KEYS FOR RTTY PRINTER

The polar relay may be eliminated and the teleprinter mechanism driven directly by a keyer such as shown here. This circuit provides loop supply and keeps the printer magnets in the ground circuit. Printer coils are placed in series for 20-ma loop operation, or in parallel for 60-ma operation. Additional printer magnets are connected either in series or parallel, to a limit of two or three before inductive effects of coils introduce undesirable side effects.

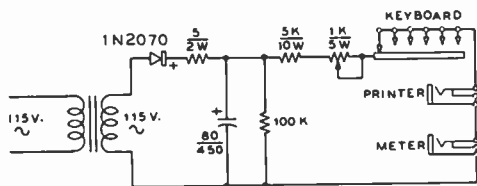

Figure 7

LOCAL LOOP SUPPLY FOR TELEPRINTER

A single teleprinter may be run as electric typewriter on local loop supply which couples the keyboard and typing mechanism in a single circuit. Depending on how the machine is wired, the keyboard and magnets can be on plugs, or connected in series internally, with only one plug (usually "red") to the loop supply.

quency shift of the oscillator is, of course, multiplied by any factor of multiplication realized in succeeding doubler stages of the transmitter. A simple diode switch suitable for many variable-frequency oscillators is shown in figure 8. Older systems often made use of a reactance tube to obtain an adjustable shift.

Auxiliary RTTY Equipment RTTY transmission by pre-punched tape is made possible by means of a *trans-*

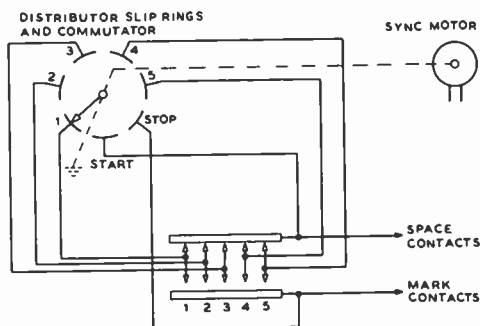

Figure 9

TRANSMITTER-DISTRIBUTOR (T-D) UNIT

T-D unit is electromechanical device which senses perforations in a teleprinter tape and translates this information into the electrical impulses of the teleprinter code. Information derived from the tape by contact fingers is transmitted in proper time sequence by a commutator-distributor driven by a constant-speed motor.

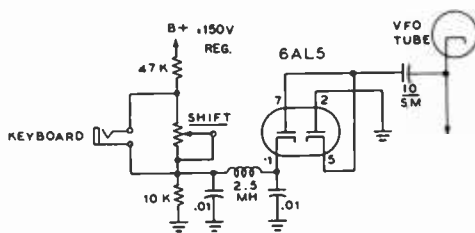

Figure 8

DIODE KEYS FOR FREQUENCY-SHIFT KEYING OF VFO

A simple diode switch may be used to vary the frequency of the transmitter in a stable manner between two chosen frequencies. The amount of shifts must match the frequency difference between the selective filters in the receiving terminal unit.

mitter-distributor (T-D) unit. This is an electromechanical device which senses perforations in a teleprinter tape and translates this information into electrical impulses of the five-unit teleprinter code at a constant speed (55-65 w.p.m. in the amateur radio service). The information derived from the

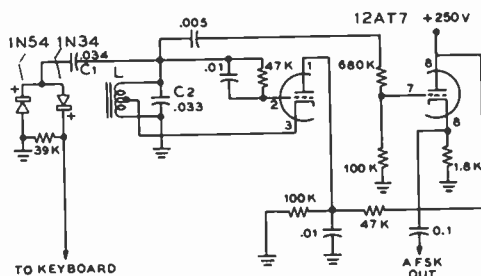

Figure 10

AFSK OSCILLATOR

Audio frequency-shift keying is often used on vhf bands to avoid problems of holding close radio-frequency stability. The L-C circuit is tuned to 2975 Hz (with keyboard open). Closing the keyboard parallels capacitor C, and lowers the oscillator frequency to 2125 Hz. The coil L is an 88 mH toroid (with about 44" of wire removed). Capacitors C, and C, are high quality paper or mylar. Compression mica capacitors may be used as padders to place the oscillator on the correct frequencies.

punched tape by contact fingers is transmitted in the proper time sequence by a commutator-distributor driven at a constant speed by a synchronous motor (figure 9). Used in conjunction with the T-D is a *tape perforator* which punches the teleprinter code in a paper tape. The perforator operates mechanically from a teleprinter keyboard for originating messages. A *reperforator* may be connected to receiving equipment to "tape" an incoming message for storage or retransmission.

Audio Frequency-Shift Keying Audio frequency-shift keying (AFSK) is often used by radio amateurs on the vhf bands in order to avoid the problems of holding close radio-frequency stability. An audio oscillator is employed to generate a 2125-Hz tone (mark) and a 2975-Hz tone (space) when driven by the keyboard of a teleprinter, or by a tape T-D unit. The audio signal is then applied to the modulator of the vhf transmitter and the resulting amplitude-modulated signal is detected and put

to use by an audio converter of the type shown in figure 4. The beat oscillator in the receiver is not used for this form of reception. AFSK is permitted only on those amateur bands on which A2 emission is authorized. A simple AFSK oscillator circuit is shown in figure 10.

Obtaining Teleprinter Machines Sources available to radio amateurs include several nonprofit RTTY societies, established in various areas of the United States for the purpose of disposing of teleprinter equipment discarded by commercial services. These societies can be contacted through active RTTY amateurs. The commercial services, including the Bell Telephone Company, generally cannot dispose of used equipment directly to radio amateurs. Commercial services should not be contacted regarding used teleprinters. Many radio amateurs, active in RTTY, rebuild machines from junked or damaged equipment at nominal cost. These amateurs are also an excellent source of maintenance support.

Single-Sideband Transmission and Reception

Single-sideband (SSB) communication is a unique, sophisticated information transmission system well suited for wire and radio services. Although known in theory for several decades, "sideband" was sparingly used in commercial service for a number of years, and only recently has it achieved popularity and general acceptance in the Amateur Service. Now, it is an important and vital communication medium and it is safe to predict that some form of single-sideband technique will someday supplant other types of intelligence transmission by electrical means. Economical in cost, sparing of valuable spectrum space, and usable under the most trying propagation conditions, SSB is the stepping stone to a future era of better and more reliable rapid communication.

16-1 The SSB System

Single sideband is a recent attempt to translate human intelligence into electrical impulses capable of being economically transmitted over great distances. The general flow of information in a communication system includes a *source*, followed by a *translator* which propagates the intelligence through a conducting *medium*. A second translator is used to extract the intelligence conveyed by the medium and to make it available in a usable form. The vocal chords, vibrations in the atmosphere, and the ear

drum accomplish this sequence of events for sound; the light source, the "ether," and the human eye provide the same sequence for sight.

Experiments before the turn of the century proved the existence of electromagnetic waves which could be propagated and put to use for transmission of information. When voice transmission via radio waves was successfully accomplished *circa* 1907, the concept of carrier waves and sidebands was unknown, although it was understood that "a channel separation high compared with the pitch of the sound waves transmitted" was required. An implication that a *transmission band* of frequencies was involved was apparently not grasped at the time, and the idea that intelligence could be transmitted by a single carrier wave of constant frequency and varying amplitude persisted until about 1921 at which time the sideband concept had been established by a series of discoveries, experiments, and inventions.

Early SSB experiments with single-sideband transmission were conducted by the telephone industry which was interested in transmitting electrical impulses corresponding to the human voice over long-distance telephone circuits. Since the transmission properties of wire and cable deteriorate rapidly with cable length and increasing frequency, a means of frequency conservation was desired which would permit the "stacking" of different voices in an electro-

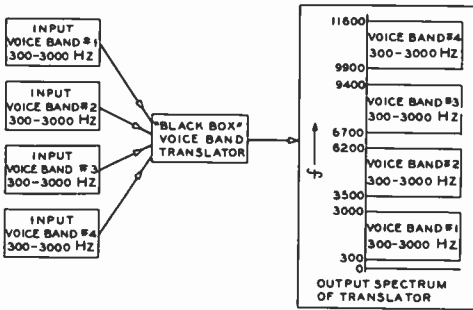

Figure 1

THE "BLACK BOX" VOICE BAND TRANSLATOR

A simple device for "stacking" voice bands in an electromagnetic "package" for transmitting many voices over a single circuit cannot be built as it is impossible to translate a band of frequencies directly to another band. Translation must be accomplished by an indirect method, making use of an auxiliary carrier wave and a mixing process termed "modulation."

magnetic package so that many voices could be sent over a single circuit. The voice impulses were mainly concentrated in the band 300—3,000 Hz and the problem at hand was to translate this voice band to a higher band of frequencies (15,300—18,000 Hz, for example) for transmission on the telephone circuit, then to reverse the translation process at the receiving terminal to recover the original band of frequencies. Experiments proved, however, that a simple and economical apparatus for translation of the voice frequencies from one band to another was not forthcoming. No device could be built that would do the job that looked so simple when sketched on paper (figure 1). It proved possible, however, to generate a continuous electrical signal at some high frequency (15,000 Hz, for example) and to impress the voice impulses on this signal. For convenience, the continuous signal was termed the *carrier wave*, as it was assumed to "carry" the intelligence in some way or other. A suitable device at the receiving terminal detected the intelligence on the carrier, recovering the original speech frequencies impressed on the carrier at the transmitter. Mathematical analysis of this process (called *modulation*) showed that the carrier remained unchanged and additional

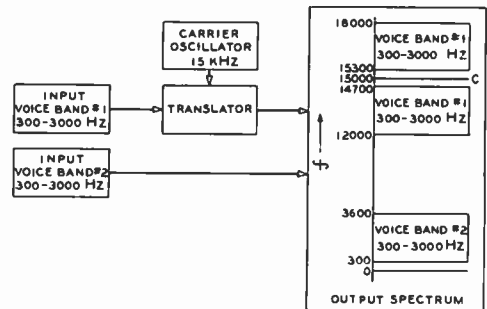

Figure 2

THE TRANSLATOR MIXER

Voice band #1 is impressed on a carrier signal in a translator (mixer) stage. Voice band #2 is unchanged. The output spectrum of the device shows that two voice bands are available, one "stacked" above the other in frequency. Addition of other translators will permit additional voice bands to be "stacked" in the frequency region between 3600 Hz and 12,000 Hz. The voice packages thus created could be sent over a single circuit. Note that the translation process creates two symmetrical voice bands from the original #1 signal, spaced each side of a carrier frequency between the bands. Elimination of carrier signal and one voice band would permit addition of another signal in this portion of the spectrum.

frequencies were created lying on either side of the carrier, spaced from it by a frequency proportional to the modulation frequency (figure 2). These additional frequencies were termed *sidebands* and conclusive evidence of separate sidebands was achieved in 1915 by the use of electric filters that separated sidebands and carriers, proving their individuality.

The sideband theory was of little more than passing interest to radio engineers, but it was a matter of considerable importance to the telephone industry. The carrier wave was useless except as an operator necessary to generate and then upon which to "hang" the two sidebands, both of which carried the same information (figure 3). For economic reasons and spectrum conservation it was desirable to remove one sideband and the carrier from the translator, passing only one sideband through the conducting medium. At the receiver, a locally generated carrier wave of the correct frequency and amplitude was combined with the incoming single-sideband signal. The re-

sulting output was a reproduction of the signal impressed on the translator. Commercial wire telephone systems using this technique were placed in operation in 1918 and the first h-f SSB telephone link was activated in 1927.

Practical Application of SSB The spectrum waste arising from a frequency translation process utilizing simple amplitude modulation could be eliminated by suppression of one sideband and the carrier, and the transmission of only the remaining sideband. To date, no method exists to directly generate an SSB signal. All translation techniques involve the use of a carrier wave, and the resulting signal includes the original carrier and two auxiliary sidebands. Elimination of the unwanted signal components was (and still is) a complex and sophisticated task.

The post-World War II acceptance of SSB transmission for military and commercial circuits has stimulated research and development in this field and has contributed to a heightened interest in the technique by the radio amateur. Mass production of sharp-cutoff filters and stable translation oscillators, plus the use of advanced and simplified circuitry has brought SSB close to the point of obsoleting simple amplitude-modulation transmission on the high-frequency amateur bands. Undoubtedly, in the years ahead, further design refinements and technical advances will make the use of SSB even more advantageous to all concerned with transmission of intelligence by electrical means.

The popularity of SSB for general amateur use has been brought about as this technique has consistently proved to allow more reliable communication over a greater range than has amplitude modulation. It has greater ability to pierce interference, static, and man-made noise than has amplitude modulation and is inherently resistant to propagation abnormalities that render a.m. completely useless. In addition, the annoying interference caused by heterodynes between a-m carriers is completely missing in SSB service. Finally, the cost of high-power SSB equipment has dropped sufficiently to compete with a-m equipment of the same or greater power capability.

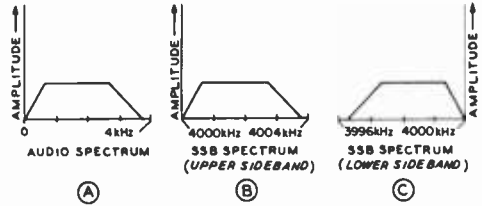

Figure 3

RELATIONSHIP OF AUDIO AND SSB SPECTRUMS

The single-sideband components are the same as the original audio components except that the frequency of each is raised by the frequency of the carrier. The relative amplitude of the various components remains the same.

Single sideband is now well established in the field of amateur radio as more and more amateurs turn toward this natural means of communication as they discover for themselves the benefits and advantages SSB can offer.

Basic SSB A single-sideband signal can be best described as an audio signal raised (mixed, or translated) to the desired radio frequency. The translation process may not result in the inversion of the audio-frequency components in the signal,

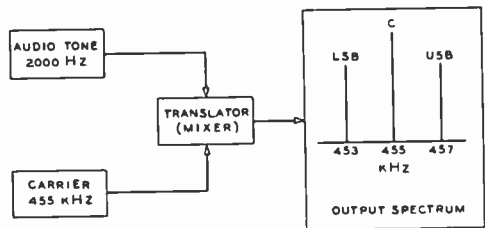

Figure 4

THE TRANSLATOR SPECTRUM

The SSB signal is an audio signal raised (mixed, or translated) to the desired radio frequency. A 455-kHz carrier signal upon which is impressed a 2-kHz audio tone in a translator stage will possess two sidebands, separated from the carrier frequency by the frequency of the tone. The carrier has been generated by the separate oscillator and the two adjacent signals (sidebands) are a product of the mixing process taking place between the audio signal and the carrier. The output spectrum pictured is of a double sideband, with carrier. To produce an SSB signal, it is necessary to eliminate the carrier and one sideband.

depending on the sideband selected (figure 4). For example, a single audio tone of 2000 Hz is to be translated into an SSB signal in the 455-kHz region. The tone is amplified and applied to one input of a translator stage (usually termed a *balanced modulator*). A radio-frequency carrier is applied to the other input terminal of the modulator. For this example, the frequency of the carrier is 455 kHz. The translation process takes place in the balanced modulator; creating two *sidebands* positioned each side of the carrier, and separated from it by the modulation frequency. Thus, at least four signals are flowing within the modulator: the 2000-Hz (2-kHz) *audio signal*, the *lower sideband* ($455 - 2 = 453$ kHz), the *carrier* (455 kHz), and the *upper sideband* ($455 + 2 = 457$ kHz). The carrier, of course, has been generated by the separate local oscillator, and the two sidebands are a product of the mixing process taking place between the audio signal and the carrier.

The balanced modulator is usually designed to balance (or cancel) the carrier signal to a large degree, leaving only the two sidebands and the audio signal to appear in the output circuit. Some modulators also balance out the audio signal. Part of the job of creating an SSB signal has now been accomplished. The high-frequency components of the output signal of the balanced modulator comprise a *double-sideband, suppressed-carrier signal*. The remaining step to create an SSB signal is to eliminate one of the sidebands and to reduce to minor proportions any vestige of carrier permitted to pass through the balanced-modulator stage. A *sideband filter* accomplishes this last step. At the output of the filter is the desired SSB signal. The passband of the filter should be just wide enough to pass the intelligence without passing the carrier wave or the unwanted sideband. For voice communication, such filters usually pass a band of radio frequencies about 2 or 3 kHz wide.

The unwanted carrier and sideband that are eliminated by the filter and balanced modulator are actually absorbed by the filter and modulator and converted to heat. In order to hold the cost and size of the filter to a reasonable figure, it is necessary that the above process take place at a relatively

low signal level, of the order of a volt or two, so that power dissipation is low.

The SSB Spectrum A single audio tone in a perfect SSB system remains a simple sine wave at all points in the system and cannot be distinguished from a c-w signal generated by more conventional means. A voice signal, on the other hand, is a complex band of audio components having many frequencies of varying amplitudes. A simple and useful compromise signal for testing SSB equipment is the *two-tone* signal, composed of two equal and separate sine waves separated a very small percentage in frequency. If two audio tones are applied to the input circuit of the SSB exciter previously discussed, the output of the 455-kHz balanced modulator will contain *four* sideband frequencies (figure 5). Assume the audio tones are 700 and 2000 Hz. The output frequencies of the balanced modulator will be: 453 kHz, 454.3 kHz, 455 kHz (the partially suppressed carrier), 455.7 kHz and 457 kHz. The two lower frequencies represent the lower sideband, and the two higher frequencies represent the upper sideband. With a properly designed filter following the balanced modulator, both the frequencies in one sideband and the remainder of the carrier will be almost completely eliminated. If the filter com-

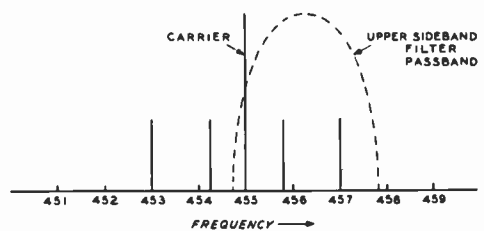

Figure 5

THE SSB SIGNAL

The SSB signal may be generated by passing a double-sideband-with-carrier signal through a filter which removes one sideband and partially suppresses the carrier. In this example, a two-tone audio signal (700 and 2000 Hz) is mixed with a 455-kHz carrier signal. The output signal from the mixer, or modulator, contains four sideband frequencies: 453 kHz, 454.3 kHz, 455.7 kHz, and 457 kHz, in addition to the carrier at 455 kHz. Additional carrier suppression may be obtained by the use of a balanced modulator.

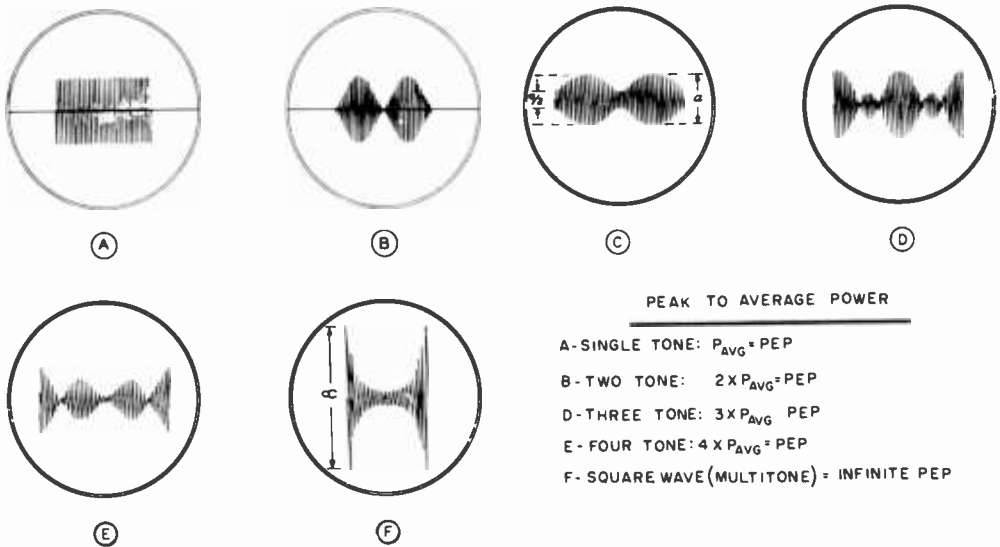

Figure 6

SSB WAVEFORMS

The waveform of the SSB signal changes with the nature of the modulating signal, and the envelope shape of the SSB wave may not be the same as the original audio waveshape. The peak power in the SSB wave is a direct function of the r-f waveform, as shown here. Peak and average power in the SSB wave will be discussed later in this chapter.

pletely eliminates the lower sideband and the carrier, the output of the exciter will be two radio frequencies at 455.7 kHz and 457 kHz. An observer examining these r-f signals could not tell if the signals were generated by two oscillators operating at the observed frequencies, or if the two signals were the result of two audio tones applied to an SSB exciter.

The waveform of the SSB signal changes drastically as the number of audio tones is increased, as shown in figure 6. A single-tone waveform is shown in illustration A and is simply a single, steady sine-wave r-f output. A signal composed of two audio tones is shown in illustration B. The two radio-frequency signals are separated by the difference in frequency between the audio tones and beat together to give the SSB envelope shown. The figure has the shape of half-sine waves, and from one null to the next represents one full cycle of the difference frequency. If one tone has twice the amplitude of the other, the envelope shape is as shown in illustration C. The SSB envelope of three equal tones of equal fre-

quency spacings and at one particular phase relationship is shown in illustration D. Illustration E shows the SSB envelope of four equal tones having equal frequency spacings and at one particular phase relationship. Finally, illustration F shows the SSB envelope of a square wave having an infinite number of odd harmonics. A pure square wave requires infinite bandwidth, so in theory the SSB envelope requires infinite amplitude. This emphasizes the point that the SSB envelope shape may not be the same as the original audio waveshape, and usually bears no similarity to it. This is because the percentage difference between the radio frequencies is small, even though one audio tone may be several times the other in terms of frequency. Because of nonlinearity and phase shift in the practical SSB transmitter, the peak amplitude of a transmitted square wave is not so great as predicted by theory through the addition of the harmonic coefficients, making it impossible to faithfully reproduce a square wave. Speech processing in the form of heavy audio clipping therefore is of limited value in SSB because

the SSB r-f envelopes are so different from the audio envelopes. A heavily clipped wave approaches a square wave which will have the tendency to exhibit the high amplitude peaks shown in illustration 6F, a waveform the SSB transmitter is theoretically unable to transmit.

The Received SSB Signal In summary, if an *audio spectrum* containing many different tones (the human voice, for example) is applied to the SSB exciter, an *r-f spectrum* is generated that corresponds to the audio tones. If the audio spectrum encompasses the range of 300—3000 Hz, the output of the 455-kHz balanced modulator will be 452 to 454.7 kHz (the lower sideband), 455 kHz (the partially suppressed carrier), and 455.3 to 458 kHz (the upper sideband). An "upper-sideband" type filter having a passband of 455.3 to 458 kHz will substantially eliminate the residual carrier and lower sideband.

Listening to the output of the SSB exciter on a typical a-m receiver will divulge a series of unintelligible sounds having no apparent relation to the original speech impressed on the SSB exciter. (A low-pitched voice can be read with difficulty as the syllabic content is preserved and is apparent). Injection in the receiver of a local carrier frequency of 455 kHz (corresponding to the suppressed carrier eliminated in the exciter) will produce intelligible speech that is a replica of the original voice frequencies.

In order to transmit simple double sideband with carrier (amplitude modulation) with this SSB exciter, it is only necessary to bypass the sideband filter and unbalance the balanced modulator. The resulting a-m signal with carrier may be intelligible on the ordinary receiver without the necessity of local-oscillator injection, the latter function being fulfilled by the transmitted carrier, if it has sufficient strength relative to the sidebands.

SSB Power Rating The SSB transmitter is usually rated at *peak envelope input or output power*. Peak envelope power (PEP) is the root-mean-square (rms) power generated at the peak of the modulation envelope. With either a two-equal-tone test signal or a single-tone test signal, the

following equations approximate the relationships between single-tone and two-tone meter readings, peak envelope power, and average power for class-B or class-AB linear amplifier operation:

Single tone:

D-C Plate Current (Meter Reading):

$$I_b = \frac{i_{pm}}{\pi}$$

Plate Input (Watts):

$$P_{in} = \frac{i_{pm} \times E_b}{\pi}$$

Average Output Watts and PEP:

$$P_o = \frac{i_{pm} \times e_p}{4}$$

Plate Efficiency:

$$N_p = \frac{\pi \times e_p}{4 \times E_b}$$

Two equal tones:

D-C Plate Current (Meter Reading):

$$I_b = \frac{2 \times i_{pm}}{\pi^2}$$

Plate Input (Watts):

$$P_{in} = \frac{2 \times i_{pm} \times E_b}{\pi^2}$$

Average Output Watts:

$$P_o = \frac{i_{pm} \times e_p}{8}$$

PEP Output Watts:

$$P_o = \frac{i_{pm} \times e_p}{4}$$

Plate Efficiency:

$$N_p = \left(\frac{\pi}{4} \right)^2 \times \frac{e_p}{E_b}$$

where,

i_{pm} equals peak of the plate-current pulse,
 e_p equals peak value of plate-voltage swing,
 π equals 3.14,

E_b equals d-c plate voltage,
 N_p equals efficiency in percent.

Power Advantage of SSB over AM

Section 97.67 of the Amateur Radio Service Rules of the FCC indi-

cates that the average power input of an SSB transmitter in the amateur service shall not exceed one kilowatt on modulation peaks, as indicated by a plate-current meter having a time constant of not more than 0.25 second. It is common practice among amateurs to define this as equivalent to a *peak envelope power* input of two kilowatts. This is convenient, since a two-tone test signal having a peak-to-average power ratio of two to one can thereby be employed for tuneup and adjustment purposes with the reasonable assumption that the SSB equipment will be properly adjusted for one kilowatt average power voice operation.

It is difficult to determine the ratio of peak to average power in the human voice, as the range of intensity of speech sounds may vary as much as 40 decibels. "Average" speech seems to have an intensity range of about 20 decibels and a ratio of instantaneous peak to average power of about 15 decibels for 99 percent of the time of speech. Speech processing (clipping or compression) may alter this figure, bringing the peak to average power ratio closer to unity. In any event, adjustment of the amateur SSB transmitter to achieve a peak power input of twice the average power input level has proven by experience to allow sufficient peak-power capability to cover the majority of cases. In those situations where the peak capability of the equipment is exceeded at an average-power input level of one kilowatt, the average-power level must be reduced to conform with the maximum capability of the transmitter. In any case, the use of an oscilloscope is mandatory to determine the peak-power capability of an SSB transmitter.

Power Advantage of SSB over AM Single sideband is a very efficient form of voice communication by radio. The amount of radio-frequency spectrum occupied can be no greater than the fre-

quency range of the audio or speech signal transmitted, whereas other forms of radio transmission require from two to several times as much spectrum space. The r-f power in the transmitted SSB signal is directly proportional to the power in the original audio signal and no strong carrier is transmitted. Except for a weak pilot carrier present in some commercial usage, there is no r-f output when there is no audio input.

The power output rating of an SSB transmitter is given in terms of *peak envelope power* (PEP). This may be defined as the rms power at the crest of the modulation envelope. The peak envelope power of a conventional amplitude-modulated signal at 100% modulation is four times the carrier power. The average power input to an SSB transmitter is therefore a very small fraction of the power input to a conventional amplitude-modulated transmitter of the same power rating.

Single sideband is well suited for long-range communications because of its spectrum and power economy and because it is less susceptible to the effects of selective fading and interference than amplitude modulation. The principal advantages of SSB arise from the elimination of the high-energy carrier and from further reduction in sideband power permitted by the improved performance of SSB under unfavorable propagation conditions.

In the presence of narrow-band manmade interference, the narrower bandwidth of SSB reduces the probability of destructive interference. A statistical study of the distribution of signals on the air versus the signal strength shows that the probability of successful communication will be the same if the SSB power is equal to one-half the power of one of the two a-m sidebands. Thus SSB can give from 0 to 9 db improvement under various conditions when the *total* sideband power is equal in SSB and regular amplitude modulation. In general, it may be assumed that 3 db of the possible 9 db advantage will be realized on the average contact. In this case, the SSB power required for equivalent performance is equal to the power in one of the a-m sidebands. For example, this would rate a 100-watt SSB and a 400-watt (carrier) a-m transmitter as having equal performance. It should be noted that in this

comparison it is assumed that the receiver bandwidth is just sufficient to accept the transmitted intelligence in each case.

To help evaluate other methods of comparison the following points should be considered. In conventional amplitude modulation two sidebands are transmitted, each having a peak envelope power equal to $\frac{1}{4}$ carrier power. For example, a 100-watt a-m signal will have 25-watt peak envelope power in each sideband, or a total of 50 watts. When the receiver detects this signal, the voltages of the two sidebands are added in the detector. Thus the detector output voltage is equivalent to that of a 100-watt SSB signal. This method of comparison says that a 100-watt SSB transmitter is just equivalent to a 100-watt a-m transmitter. This assumption is valid only when the receiver bandwidth used for SSB is the same as that required for amplitude modulation (e.g., 6 kHz), when there is no noise or interference other than broadband noise, and if the a-m signal is not degraded by propagation. By using half the bandwidth for SSB reception (e.g., 3 kHz) the noise is reduced 3 db so the 100-watt SSB signal becomes equivalent to a 200-watt carrier a-m signal. It is also possible for the a-m signal to be degraded another 3 db on the average due to narrow-band interference and poor propagation conditions, giving a possible 4 to 1 power advantage to the SSB signal.

It should be noted that 3 db signal-to-noise ratio is lost when receiving only one sideband of an a-m signal. The narrower receiving bandwidth reduces the noise by 3 db but the 6 db advantage of coherent detection is lost, leaving a net loss of 3 db. Poor propagation will degrade this "one-sideband" reception of an a-m signal less than double-sideband reception, however. Also under severe narrow-band interference conditions (e.g., an adjacent strong signal) the ability to reject all interference on one side of the carrier is a great advantage.

Advantage of SSB with Selective Fading On long-distance communication circuits using amplitude modulation, selective fading often causes severe distortion and at times makes the signal unintelligible. When one sideband is weaker than the other, distortion results; but when the

carrier becomes weak and the sidebands are strong, the distortion is extremely severe and the signal may sound like "monkey chatter." This is because a carrier of at least twice the amplitude of either sideband is necessary to demodulate the signal properly. This can be overcome by using *exalted-carrier reception* in which the carrier is amplified separately and then reinserted before the signal is demodulated or detected. This is a great help, but the reinserted carrier must be very close to the same phase as the original carrier. For example, if the reinserted carrier were 90 degrees from the original source, the a-m signal would be converted to phase modulation and the usual a-m detector would deliver no output.

The phase of the reinserted carrier is of no importance in SSB reception and by using a strong reinserted carrier, exalted-carrier reception is in effect realized. Selective fading with one sideband simply changes the amplitude and the frequency response of the system and very seldom causes the signal to become unintelligible. Thus the receiving techniques used with SSB are those which inherently greatly minimize distortion due to selective fading.

SSB Amplification and Frequency Changing The single-sideband signal appearing at the output of the filter must be amplified to a sufficiently strong level for practical use. The amplifying stage must have low distortion and the output signal must be a faithful replica of the input signal. An amplifier meeting these requirements is called a *linear amplifier*. Any deviation from amplitude linearity produces signal distortion and spurious products which rapidly degrade the SSB signal. It is therefore impossible to pass the SSB signal through frequency doublers or class-C amplifiers without creating severe distortion, because these are inherently nonlinear devices. Linear amplifier stages must be used, and if a change of frequency of the SSB signal is desired, it must be heterodyned to the new frequency by means of a mixer stage and another local oscillator (figure 7). The resulting signal may be vfo controlled by varying the frequency of the local oscillator, but the frequency at which the SSB signal is generated is held constant. Thus,

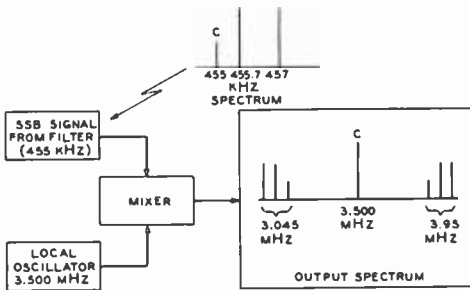

Figure 7

SSB FREQUENCY TRANSLATION

The SSB signal may be translated higher in frequency in the same manner the voice signals are translated to a radio-frequency spectrum. In this example, the 455-kHz two-tone, suppressed-carrier signal is translated (mixed) with a 3.5-MHz oscillator to provide two new sidebands, one at 3.045 MHz and the other at 3.95 MHz. If the 3.95-MHz signal is desired, filter circuits may be used to eliminate the unwanted 3.045-MHz sideband and the 3.5-MHz carrier signal from the local oscillator. The 3.95-MHz signal may now be shifted in frequency by changing the frequency of the local oscillator.

by means of linear amplifiers and mixer stages, a low frequency SSB signal may be amplified and converted to any other frequency desirable for communication purposes.

16-2 A Basic Single-Sideband Transmitter

The general outline of a practical SSB transmitter suitable for high-frequency oper-

ation can be assembled from the preceding information. A block diagram of such a unit is shown in figure 8. The transmitter consists of a speech amplifier, a carrier oscillator, a balanced modulator, a sideband filter, a high-frequency mixer stage and conversion oscillator, and a linear amplifier having a high-Q tuned output circuit. Incidental equipment such as power supplies and metering circuits are also necessary. Many variations of this basic block diagram are possible.

The Speech Amplifier—A typical speech amplifier consists of a microphone which converts the voice into electrical signals in the audio band, followed by one or more stages of voltage amplification. No appreciable audio power output is required making the audio system of the SSB transmitter quite different from that of the usual a-m transmitter, which requires an audio power level equal to one-half the class C amplifier power input. Included in the speech system is a *speech level* (audio volume) *control* and additional stages to allow *automatic voice operation* (VOX) of the equipment.

The Carrier Oscillator—A highly stable r-f oscillator (often crystal-controlled) is used to generate the carrier signal required in the mixing process. The choice of carrier frequency is determined by the design of the sideband filter, and frequencies in the range of 250 kHz to 20 MHz are common. Power output is low and frequency stability is a prime necessity in this circuit.

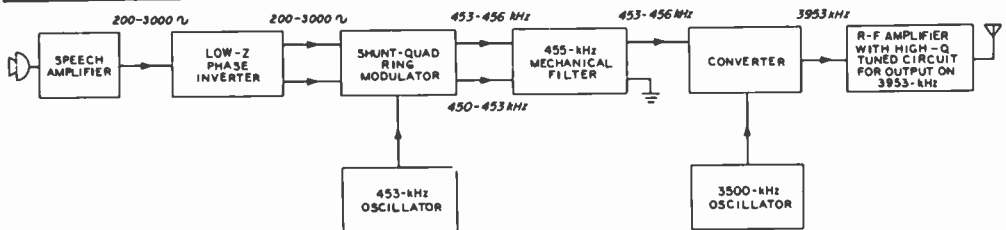

Figure 8

BLOCK DIAGRAM OF FILTER-TYPE SSB TRANSMITTER

Voice frequencies in the range of 200 to 3000 Hz are amplified and fed to a balanced modulator. Depending on the choice of frequency of the local oscillator, either the upper or lower sideband may be passed through to the mechanical filter. The carrier has, to some extent, been reduced by the balanced modulator. Additional carrier rejection is afforded by the filter. The SSB signal at the output of the filter is translated directly to a higher operating frequency. Suitable tuned circuits follow the converter stage to eliminate the conversion oscillator signal and the image signal.

The Balanced Modulator—The balanced modulator translates the audio frequencies supplied by the speech amplifier into r-f sidebands adjacent to the carrier generated by the carrier oscillator. In addition, the balanced modulator partially rejects the carrier which has no further use after the mixing process is completed. A *carrier-balance (null) control* is an integral part of this circuit and is adjusted for optimum carrier suppression.

The Sideband Filter—Selection of one of the two sidebands at the output of the balanced modulator is the function of the filter. A practical filter may consist of small tuned LC circuits, or it may consist of mechanical resonators made of quartz or steel. A representative passband for a sideband filter is shown in figure 9. The filter must provide a sharp cutoff between the wanted sideband and the carrier, as well as rejection of the unwanted sideband.

The Converter (Mixer) Stage and Conversion Oscillator—It is usually necessary to obtain an SSB signal at a frequency other than that of the sideband filter passband. Frequency conversion is accomplished in the same manner the voice frequencies were translated to the filter frequency re-

gion; that is, by the use of a converter stage and conversion oscillator. The process carried out in this step may be referred to as *translation, mixing, heterodyning, or converting*. For this example, it is desired to convert a 455-kHz SSB signal to 3.95 MHz. The operation takes place in a second balanced-modulator circuit. One input is the 455-kHz SSB signal, and the other input signal is from an oscillator operating on 3.500 MHz. The output of the second mixer is a partially suppressed carrier (3.500 MHz), the lower sideband in the 3.045-MHz range ($3.500 - 0.455 = 3.045$ MHz), and the upper sideband in the 3.95-MHz range ($3.500 + 0.455 = 3.95$ MHz). The upper sideband is the desired one, so a simple auxiliary *image filter* is used to separate it from the unwanted sideband and the partially suppressed carrier. In most cases, this filter consists of the two or three parallel-tuned circuits normally associated with the following amplifier stages tuned to 3.95 MHz.

The Linear Amplifier—The output of the last mixer stage is usually of the order of a few milliwatts and must be amplified to a usable level in one or more *linear amplifier* stages. For lowest distortion, the output of the linear amplifier should be a nearly exact reproduction of its input signal. Any amplitude nonlinearity in the amplifier not only will produce undesirable distortion within the SSB signal, but will also produce annoying spurious products in adjacent channels. Distortion may be held to a low value by the proper choice of tubes, their operating voltages and driving-circuit considerations, and by the use of external negative feedback, as discussed in Chapter Twelve.

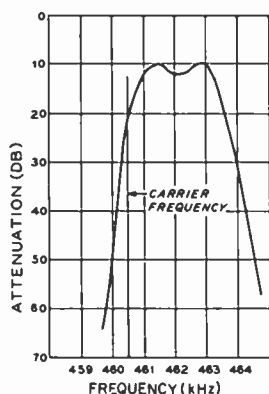

Figure 9

PASSBAND OF CRYSTAL LATTICE FILTER

A 460.5-kHz crystal-lattice filter composed of eight crystals has an excellent passband for voice waveforms. Carrier rejection is about -20 decibels, and unwanted sideband rejection is better than -35 decibels. Passband is essentially flat up to 463 kHz, providing an audio passband of about 300 to 2500 Hz.

16-3 The Balanced Modulator

The *balanced modulator* is used to mix the audio signal with that of the local carrier to produce sideband components which may be selected for further amplification. Any *nonlinear* element will serve in a modulator, producing sum and difference signals as well as the original frequencies. This phenomenon is objectionable in amplifiers

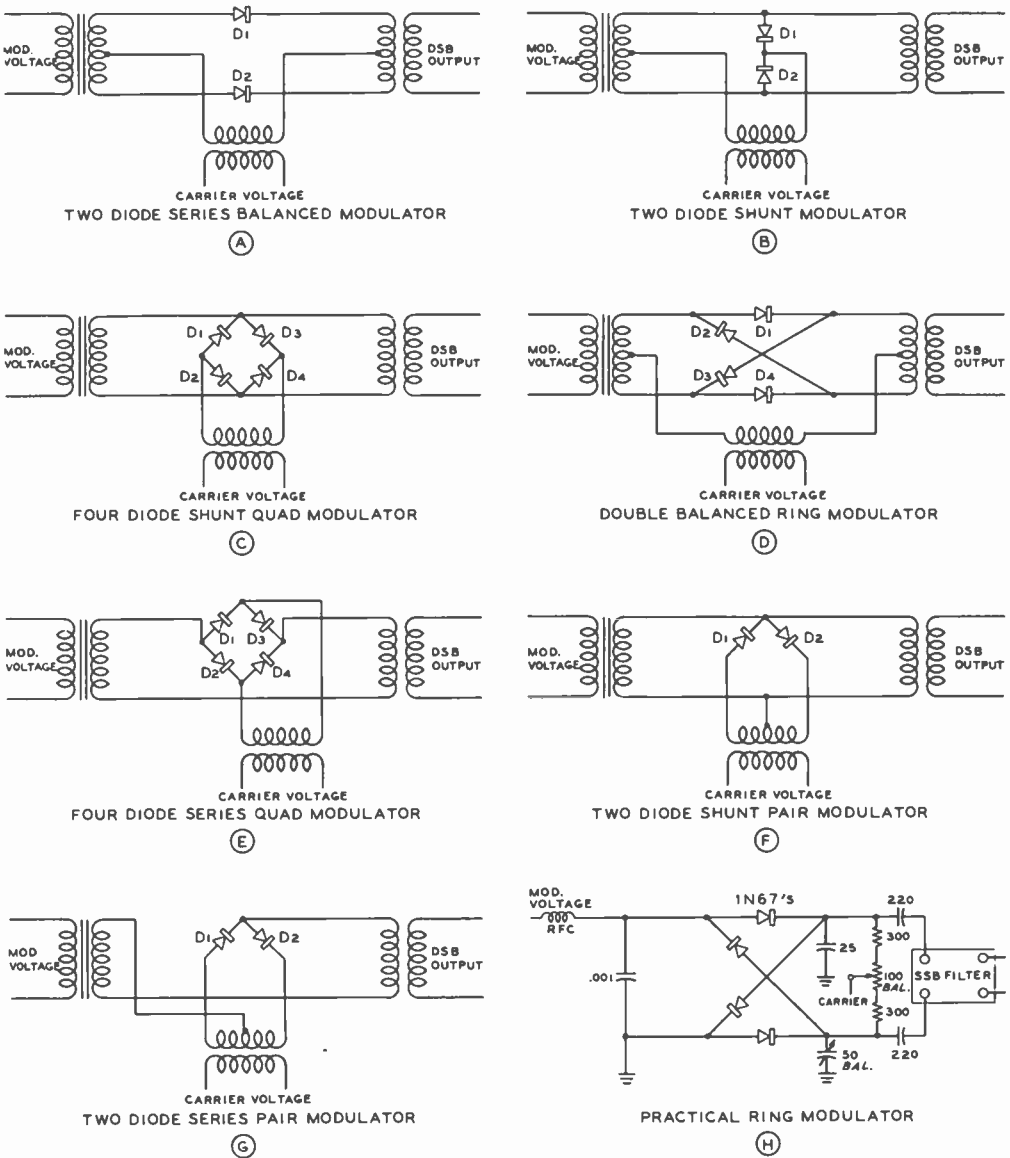

Figure 10

BALANCED-MODULATOR CIRCUITS

The balanced modulator is used to mix the audio signal with that of the carrier to produce sideband components. It may also be used as a converter or mixer stage to convert an SSB signal to a higher frequency. The diodes act as an r-f driven switch and may be arranged in series or shunt mode as shown in the illustrations. A practical diode modulator incorporating balancing circuits is shown in illustration H.

and desirable in mixers or modulators. The simplest modulator is a rapid-action switch, commonly simulated by diode rectifiers for r-f service. Either semiconductors or vacu-

um-tube rectifiers may be employed and some of the more commonly used circuits are shown in figure 10. The simplest modulator is that of figure 10A, the two-diode

series-balanced modulator. The input transformer introduces the audio signal to the balanced diode switches, which are turned off and on by the carrier voltage introduced in an in-phase relationship. If the carrier amplitude is large with respect to the audio signal, the only current flowing in the output transformer is due to the action of the audio voltage added to the carrier voltage. A properly designed DSB output transformer will filter out the switching transients, the audio component, and the carrier signal, leaving only the desired double-sideband output. A shunt version of this circuit is shown in illustration B wherein the diodes form a short-circuit path across the input transformer on alternate half-cycles of carrier switching voltage.

Four-diode balanced modulators are shown in illustrations C through E. Circuits C and E are similar to the two-diode circuits except that untapped transformers may be used to save cost. The double-balanced ring circuit of illustration D is popular as both carrier and audio signal are balanced with respect to the output, which is advantageous when the output frequency is not sufficiently different from the inputs to allow ready separation by inexpensive filters. The series and shunt-quad configuration may be adapted to two diodes as shown in illustrations F and G, substituting a balanced carrier transformer for one side of the bridge. In applying any of these circuits, r-f chokes and capacitors must be employed to control the path of audio and carrier currents and balancing capacitors are usually added to null the carrier as shown in the circuit of illustration H.

Vacuum-tube diodes such as the 6AL5 may be used in these circuits, having the advantage of zero reverse current as compared to semiconductor devices, but suffer from contact potential at low signal levels and, when conducting, have a higher resistance, than good semiconductor units.

The double-diode circuits appear attractive, but in general it is more difficult to balance a transformer at the carrier frequency than it is to use an additional pair of diodes. Untapped transformers are desirable, eliminating this critical component from the circuit. Paired diodes combined with balancing potentiometers and capacitors usual-

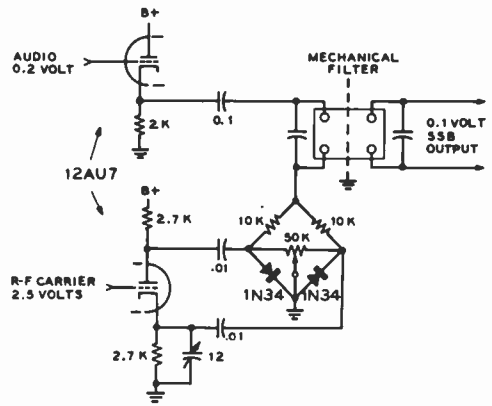

Figure 11

SERIES-CONNECTED BALANCED MODULATOR

Audio and carrier signals are impressed on a diode modulator connected in series with sideband filter. Both resistive and capacitive carrier balance controls are used. The audio signal is taken from a low-impedance cathode follower and the balanced carrier signal is derived from a phase-splitter in cathode and plate circuits of a triode tube.

ly provide the best compromise, permitting a high degree of carrier balance at minimum cost and maximum effectiveness. An example of a typical diode modulator circuit is shown in figure 11.

Vacuum-Tube Modulators

Two modulated amplifiers may be connected with the carrier inputs 180° out of phase, and with the carrier outputs in parallel. The carrier will be balanced out of the output circuit, leaving only the two sidebands. The audio signal or the injected carrier may be applied either in push-pull or parallel mode, some of the most commonly used circuits being shown in figure 12. The use of vacuum-tube triode and pentagrid modulators permits the use of high-impedance audio and carrier sources, but this advantage may often be counterbalanced by the fact that carrier balance may be dependent on signal levels and that the balance drifts with time and environment.

16-4 The Sideband Filter

The heart of a filter-type SSB exciter is the sideband filter. Conventional coils and

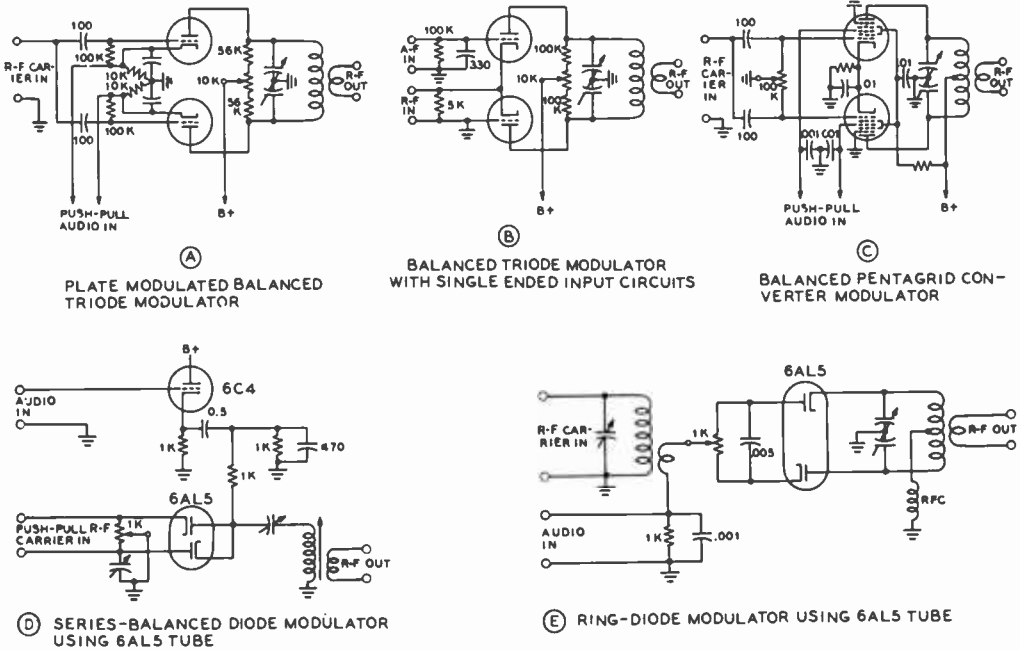

Figure 12

THE BALANCED MODULATOR

Two modulated amplifiers or mixers may be connected with the outputs out of phase with the carrier input signal. The carrier will be balanced out of the output circuit, leaving only the two sidebands. Illustrations A and B show typical triode circuits. Illustration C shows pentagrid converters using 6BE6 or 6BA7 tubes. Circuits D and E may also use semiconductor diodes (such as the 1N34) in place of the 6AL5.

capacitors may be used to construct a filter based on standard wave-filter techniques. Such filters are restricted to relatively low frequencies because of the rapid cutoff required between the filter passband and adjacent stopbands. The Q of the filter inductors must be relatively high when compared with the reciprocal of the fractional bandwidth. If a bandwidth of 3 kHz is needed at a carrier frequency of 50 kHz, for example, the bandwidth expressed in terms of the carrier frequency is 3/50, or 6 percent. This is expressed in terms of fractional bandwidth as 1/16. For satisfactory operation, the Q of the filter inductances should be ten times the reciprocal of this, or 160.

For voice communication purposes, the lower frequency response of the sideband filter is usually limited to about 300 Hz. Frequencies above 2500 Hz or so contribute little to speech intelligence, moreover, and their elimination permits closer grouping

for SSB signals. Practical filters for speech transmission, therefore, have a passband from about 300 to 2500 Hz or so, rejecting signals in the unwanted passband and those above 3000 Hz by over 40 decibels. A ten-pole LC SSB filter and the characteristic response is shown in figure 13.

Crystal Filters Practical and inexpensive SSB filters may be designed around quartz crystal resonators at center frequencies well into the h-f range. Home-made lattice-type filters of the type shown in figure 14 may be made of surplus low-frequency crystals. Experimental designs usually synthesize a selectivity curve by grouping sharp notches at the sides of the passband. Where the width of the passband is greater than twice the spacing of the series and parallel resonances of the crystal, special circuit techniques must be used.

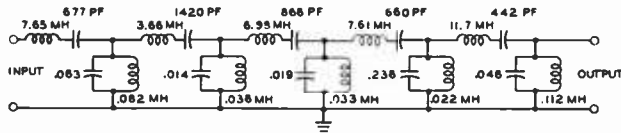

Figure 13
TEN-POLE BUTTERWORTH-TYPE SSB FILTER

The carrier frequency is 70 kHz and filter impedance is 600 ohms. Each series-resonant and parallel-resonant circuit is tuned to the carrier frequency. Using high-Q inductors, the filter passband is about 4 kHz wide at a response of -40 decibels. Noise of filter is about 2500 Hz wide. Low-frequency SSB filters of this type require two or more conversion stages to provide h-f SSB signal without troublesome images. High-frequency quartz-crystal filters, on the other hand, make possible SSB exciters capable of single conversion operation up to 50 MHz or so.

Mechanical Filters Filters using mechanical resonators have been studied by a number of companies and are offered commercially by the *Collins Radio Co.* They are available in a variety of bandwidths at center frequencies of 250 and 455 kHz. The 250-kHz series is specifically intended for sideband selection. The selectivity attained by these filters is intermediate between good LC filters at low center frequencies and engineered quartz-crystal filters. A passband of two 250-kHz filters is shown in figure 15. In application of the mechanical filters some special precautions are necessary. The driving and pickup coils should be carefully resonated to the operating frequency. If circuit capacitances are unknown, trimmer capacitors should be used across the coils. Maladjustment of these tuned coils will increase insertion loss and the peak-to-valley ratio. On high-impedance filters (ten- to twenty-thousand ohms) signals greater than 2 volts at the input should be avoided. Direct current should be blocked out of the end coils. While the filters are rated for 5 ma of coil current, they are not rated for d-c plate voltage.

16-5 The Phasing Type SSB Exciter

An SSB signal may be generated by the phasing of two a-m signals in such a way that one sideband is enhanced, and the other sideband and carrier are cancelled or balanced out. This technique is known as the *phasing system* and exchanges the problems of filter design for those of accurately controlled phase shifts. In general, the phasing transmitter is more economical in cost than is the filter-type transmitter and may be less complex. It requires adjustment of various audio and r-f balancing controls for maximum suppression of the unwanted sideband and carrier that is otherwise accomplished by bandpass-filter action in the filter-type equipment. The phasing system has the advantage that all electrical circuits which give rise to the SSB signal can operate in a practical transmitter at the nominal output frequency of the transmitter. Thus, if an SSB signal is desired at 50.1 MHz, it is not necessary to go through several frequency conversions in order to obtain an

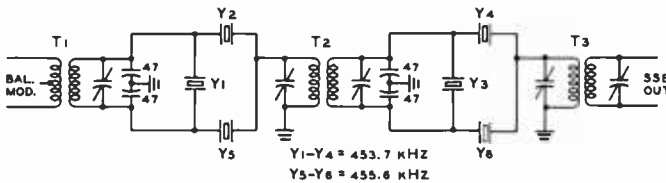

Figure 14

CRYSTAL-LATTICE FILTER

This crystal lattice filter is designed for a carrier frequency of 453.7 kHz. Surplus crystals are used. Y_1 - Y_4 are marked Channel 45, 24.5 MHz. Y_5 - Y_6 are marked Channel 46, 24.6 MHz. Transformers T_2 and T_3 are standard 455-kHz units. Transformer T_1 is a standard unit with one winding removed. A bifilar primary winding of 25 turns is wound in place of the removed winding. One 25-turn winding is applied, and a second 25-turn winding placed over it, with the end of the first winding connected to the beginning of the second. The common connection is the center tap. The transformers are aligned at the center of the passband (455.5 kHz). When properly aligned, carrier rejection is better than -25 decibels and the nominal filter bandwidth is about 2500 Hz.

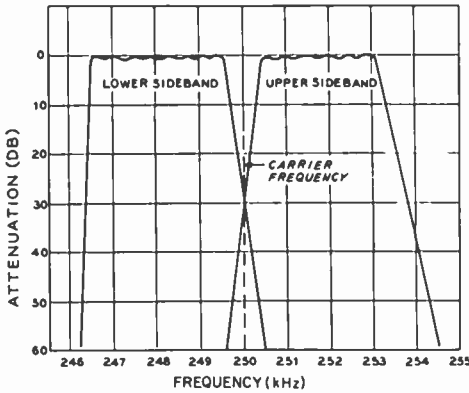

Figure 15

PASSBAND OF LOWER- AND UPPER-SIDEBAND MECHANICAL FILTER

SSB signal at the desired output frequency. The balanced modulator in the phasing transmitter is merely fed with a 50.1 MHz carrier and with the audio signal from a balanced phase splitter. Practical considerations, however, make the construction of a 6-meter SSB phasing-type exciter a challenge to the home constructor because of the closely controlled r-f phase shifts that must be achieved at that frequency.

A Practical Phasing Exciter A simplified block diagram illustrating the phasing method of SSB generation is shown in figure 16. An audio signal is

amplified, restricted in bandwidth by a speech filter and then split into two branches (ϕ_1 and ϕ_2) by the *audio phase network*. The resulting signals are applied independently to two balanced modulators. The audio networks have the property of holding a 90° *phase difference* between their respective output signals within the restricted range of audio frequencies passed by the speech filter and applied to their input terminals. In addition, the amplitude response of the networks remains essentially constant over this frequency range.

Each balanced modulator is driven by a fixed-frequency carrier oscillator whose output is also split into two branches (θ_1 and θ_2) by a 90° r-f phase shift network operating at the carrier frequency. The algebraic sum of the output signals of the two balanced modulators appears at the output of a combining circuit and is the desired single-sideband, suppressed-carrier signal. The degree of sideband suppression is dependent on the control of audio phase shift and amplitude balance through the system; a phase error of two degrees, for example, will degrade the sideband attenuation by over 10 decibels.

By way of illustration, assume that the carrier oscillator frequency is 3.8 MHz and that a single modulating tone of 2000 Hz is used. The output from balanced modulator #1 is represented by the spectrum plot of figure 17A, in which the carrier frequency

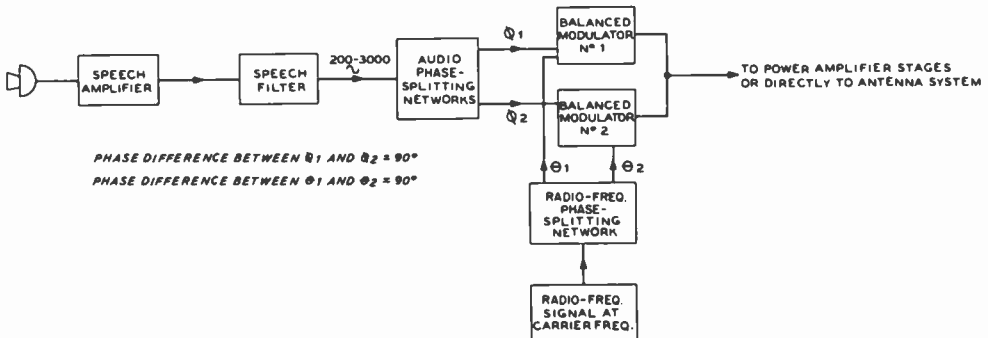

Figure 16

BLOCK DIAGRAM OF THE "PHASING" METHOD

The phasing method of obtaining a single-sideband signal is simpler than the filter system in regard to the number of tubes and circuits required. The system is also less expensive in regard to the components required, but is more critical in regard to adjustments for the transmission of a pure single-sideband signal.

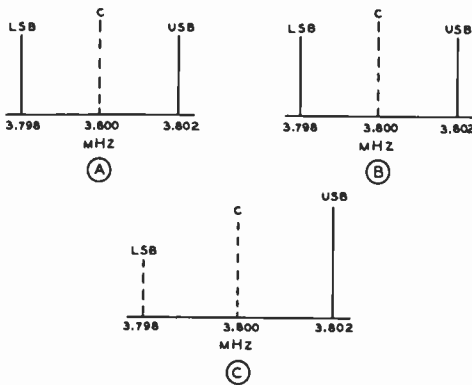

Figure 17

THE PHASING-TYPE SSB SIGNAL

Two signals having identical spectrum plots may be combined to produce an SSB signal. The signals of illustrations A and B, however, have simultaneous 90-degree phase shifts applied to the audio and carrier signals and when properly combined produce an SSB signal whose lower sidebands are out of phase and whose upper sidebands are in phase. By use of twin balanced modulators, the carrier may be suppressed and proper sideband addition and subtraction achieved (illustration C).

is represented by the vertical dashed line at 3.8 MHz with the symmetrical sidebands at 3.798 MHz and 3.802 MHz. The carrier frequency is balanced within the modulator and so does not appear in its output. Similarly, the output of balanced modulator #2 produces a signal which has an identical spectrum plot, as shown in figure 17B. While the spectrum plots appear identical, they do not show everything about the output signals of the two modulators as addition of two identical quantities yields a result which is simply twice as great as either quantity. However, the result of the two simultaneous 90° phase shifts applied to the audio and carrier signals impressed on the modulators produces sideband signals in their respective outputs that are *in phase* for the identical upper-sideband frequency of 3.802 MHz but 180° *out of phase* for the lower-sideband frequency of 3.798 MHz as shown in figure 17C. Addition of the output signals of the two balanced modulators thus doubles the strength of the upper-sideband component while balancing out the lower-sideband component. Conversely, subtraction of the output signals of one bal-

anced modulator from those of the other will double the strength of the lower-sideband component while cancelling the upper-sideband component. In either case, an SSB signal is created. A double-pole, double-throw reversing switch in two of the four audio leads to the balanced modulators is all that is required to switch from one sideband to the other.

The phase-shift method works not so much because the system passes a certain band of frequencies but because it is able to cancel a closely adjacent band of frequencies. The result, however, is equivalent to that obtained by the use of bandpass filters.

Filter versus Phasing?

The phasing system of SSB generation does not necessarily produce a better or worse signal than does the filter-type of SSB generator. Suppression of the unwanted sideband in the phasing generator depends on the characteristic of the audio phase-shift networks and on matching the differential phase shift these networks provide to the r-f phase shift at carrier frequency. These adjustments must be accomplished by the equipment operator. On the other hand, in this filter-type SSB generator, unwanted sideband suppression depends on the built-in characteristics of the sideband filter and on the placement of the carrier relative to the filter passband. How well the job is done in each case is primarily a matter of design and cost—not one of basic superiority of one method over the other. Reduced cost of high-frequency crystal filters has dropped the price of the filter equipment to that of the previously less-expensive phasing system and most of today's commercial and amateur SSB gear makes use of the filter technique of sideband generation. Even so, for equivalent quality of components and design, it would be hard for an observer to tell whether a given SSB signal was generated by the phasing method or by the filter method.

Balanced Modulator Circuits Illustrated in figure 18 are the basic balanced modulator circuits which give good results with a radio-frequency carrier and an audio modulating signal. Note

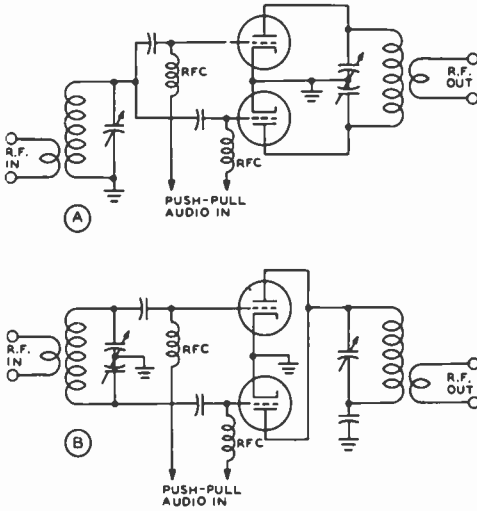

Figure 18

SHOWING TWO COMMON TYPES OF BALANCED MODULATORS

Notice that a balanced modulator changes the circuit condition from single ended to push-pull, or vice versa. Choice of circuit depends on external circuit conditions since both the A and B arrangements can give satisfactory generation of a double-sideband suppressed-carrier signal.

that one push-pull and one single-ended tank circuit is required, but that the push-pull circuit may be placed either in the plate or the grid circuit. Also, the audio modulating voltage always is fed into the stage in push-pull, and the tubes normally are operated class A.

When combining two balanced modulators to make up a double balanced modulator as used in the generation of an SSB signal by the phasing system, only one plate circuit is required for the two balanced modulators. However, separate grid circuits are required since the grid circuits of the two balanced modulators operate at an r-f phase difference of 90 degrees. Note that the circuit of figure 19A is derived from the balanced modulator of figure 18A, and similarly figure 19B is derived from figure 18B.

Another circuit that gives excellent performance, and is very easy to adjust is shown in figure 20. The audio signal and r-f source are applied in series to two diodes serving as balanced modulators having a push-pull

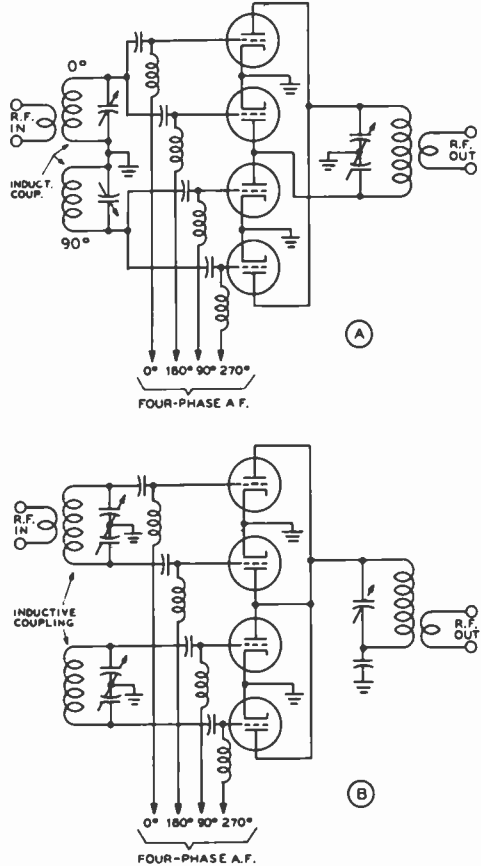

Figure 19

TWO CIRCUITS FOR SINGLE-SIDE-BAND GENERATION BY THE PHASING METHOD.

The circuit of A offers the advantages of simplicity in the single-ended input circuits plus a push-pull output circuit. Circuit B requires double-ended input circuits but allows all the plates to be connected in parallel for the output circuit.

output circuit tuned to the carrier frequency.

Radio-Frequency Phasing A single-sideband generator of the phasing type requires that the two balanced modulators be fed with r-f signals having a 90-degree phase difference. This r-f phase difference may be obtained through the use of two loosely coupled resonant circuits, such as illustrated in figure 19A and 19B.

The r-f signal is coupled directly or inductively to one of the tuned circuits, and the coupling between the two circuits is varied until, at resonance of both circuits, the r-f voltages developed across each circuit have the same amplitude and a 90-degree phase difference.

The 90-degree r-f phase difference also may be obtained through the use of a low-Q phase-shifting network, such as illustrated in figure 21; or it may be obtained through the use of a lumped-constant quarter-wave line. The low-Q phase-shifting system has proved quite practical for use in single-sideband systems, particularly on the lower frequencies. In such an arrangement the two resistances (R) have the same value, usually in the range between 100 and a few thousand ohms. Capacitor C, in shunt with the input capacitances of the tubes and circuit capacitances, has a reactance at the operating frequency equal to the value of resistor R. Also, inductor L has a net inductive reactance equal in value at the operating frequency to resistance R.

The inductance chosen for use at L must take into account the cancelling effect of the input capacitance of the tubes and the circuit capacitance; hence the inductance should be variable and should have a lower value of inductance than that value of inductance which would have the same reactance as resistor R. Inductor L may be considered as being made up of two values of inductance in parallel: (1) a value of inductance which will resonate at the operating frequency with the circuit and tube capacitances, and (2) the value of inductance which is equal in reactance to resistance R. In a network such as shown in figure 21,

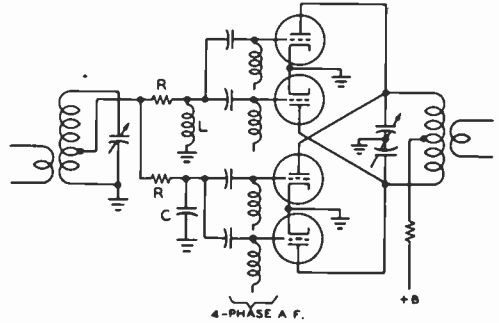

Figure 21

LOW-Q R-F PHASE-SHIFT NETWORK

The r-f phase-shift system illustrated above is convenient in a case where it is desired to make small changes in the operating frequency of the system without the necessity of being precise in the adjustment of two coupled circuits as used for r-f phase shift in the circuit of figure 19.

equal and opposite 45-degree phase shifts are provided by the RL and RC circuits, thus providing a 90-degree phase difference between the excitation voltages applied to the two balanced modulators.

Audio-Frequency Phasing

The audio-frequency phase-shifting networks used in generating a single-sideband signal by the phasing method usually are based on those described by Dome in an article in the December, 1946, *Electronics*. A relatively simple network for accomplishing the 90-degree phase shift over the range from 160 to 3500 Hz is illustrated in figure 22. The values of resistance and capacitance must be carefully checked to ensure minimum deviation from a 90-degree phase shift over the 200- to 3000-Hz range.

Another version of the Dome network is shown in figure 23. This network employs three 12AU7 tubes and provides balanced output for the two balanced modulators. As with the previous network, values of the resistances within the network must be held to very close tolerances. It is necessary to restrict the speech range to 300 to 3000 Hz with this network. Audio frequencies outside this range will not have the necessary phase-shift at the output of the network and will show up as spurious emissions on the sideband signal, and also in the region of the

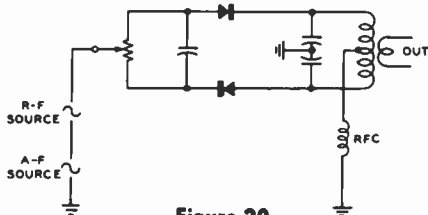

Figure 20

SERIES DIODE MODULATOR CIRCUIT

R-f and a-f sources are applied in series to balanced modulator.

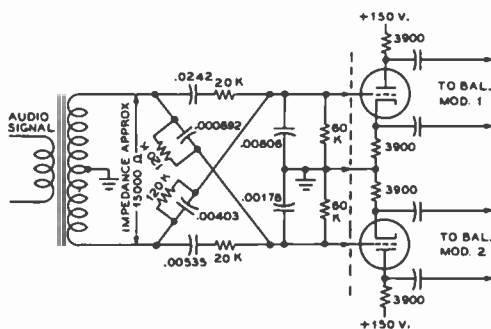

Figure 22

DOME AUDIO-PHASE-SHIFT NETWORK

This circuit arrangement is convenient for obtaining the audio phase shift when it is desired to use a minimum of circuit components and tube elements.

rejected sideband. A low-pass 3500-Hz speech filter, such as the *Stancor Electronics Co. LPF-2* should be used ahead of this phase-shift network.

A passive audio phase-shift network that employs no tubes is shown in figure 24. This network has the same type of operating restrictions as those described above. Additional information concerning phase-shift networks will be found in *The Single Sideband Digest* published by the American Radio Relay League. A comprehensive sideband review is contained in the December, 1956 issue of *Proceedings of the I.E.E.E.*

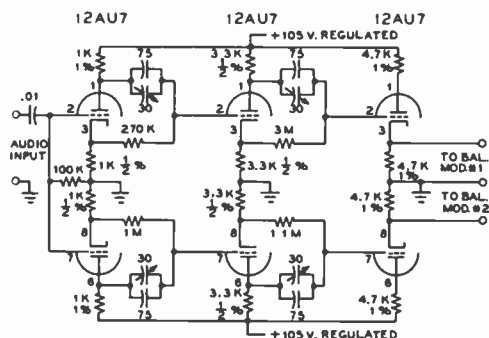

Figure 23

A VERSION OF THE DOME AUDIO-PHASE-SHIFT NETWORK

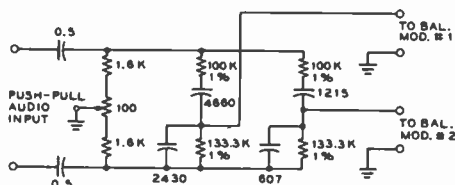

Figure 24

PASSIVE AUDIO-PHASE-SHIFT NETWORK, USEFUL OVER RANGE OF 300 TO 3000 Hz.

16-6 Single-Sideband Frequency Conversion

The output signal from the low-level SSB generator is usually at a fixed frequency and must be converted, or translated, to the desired operating frequency. This conversion is accomplished by a heterodyne process involving converter or mixer stages and suitable oscillators. Frequency multipliers cannot be used with the SSB signal since this process would alter the frequency relationships present in the original audio signal.

The heterodyne process mixes two signals in a manner to produce new signal components equal in frequency to the sum and difference of the original frequencies. One of the two products is useful and is passed by the tuned circuits of the equipment which rejects the undesired products as well as the original signals. Mixing imposes many problems in keeping the output signal free from spurious products created in the mixer. Selection of mixing frequencies and signal levels is required to aid in holding the level of unwanted products within reasonable limits. A discussion of frequency-conversion problems will follow later in this chapter.

Mixer Stages One circuit which can be used for this purpose employs a receiving-type mixer tube, such as the 6BE6. The output signal from the SSB generator is fed into the #1 grid and the conversion frequency into the #3 grid. This is the reverse of the usual grid connections, but it offers about 10 db improvement in distortion. The plate circuit is tuned to select the desired

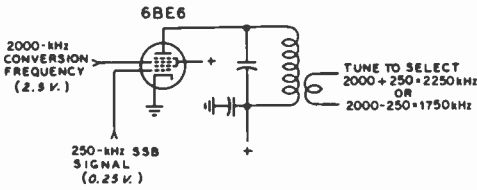

Figure 25

PENTAGRID MIXER CIRCUIT FOR SSB FREQUENCY CONVERSION

output frequency product. Actually, the output of the mixer tube contains all harmonics of the two input signals and all possible combinations of the sum and difference frequencies of all the harmonics. In order to avoid distortion of the SSB signal, it is fed to the mixer at a low level, such as 0.1 to 0.2 volts. The conversion frequency is fed in at a level about 20 db higher, or about 2 volts. By this means, harmonics of the incoming SSB signal generated in the mixer tube will be very low. Usually the desired output frequency is either the sum or the difference of the SSB generator carrier frequency and the conversion frequency. For example, using an SSB generator carrier frequency of 250 kHz and a conversion injection frequency of 2000 kHz as shown in figure 25, the output may be tuned to select either 2250 or 1750 kHz.

Not only is it necessary to select the desired mixing product in the mixer output but also the undesired products must be highly attenuated to avoid having spurious output signals from the transmitter. In general, all spurious signals that appear within the assigned frequency channel should be at least 60 db below the desired signal, and those appearing outside of the assigned frequency channel at least 80 db below the signal level.

When mixing 250 kHz with 2000 kHz as in the above example, the desired product is the 2250-kHz signal, but the 2000-kHz injection frequency will appear in the output about 20 db stronger than the desired signal. To reduce it to a level 80 db below the desired signal means that it must be attenuated 100 db.

The principal advantage of using balanced-modulator mixer stages is that the injection frequency theoretically does not ap-

pear in the output. In practice, when a considerable frequency range must be tuned by the balanced modulator and it is not practical to trim the push-pull circuits and the tubes into exact amplitude and phase balance, about 20 db of injection-frequency cancellation is all that can be depended on. With suitable trimming adjustments the cancellation can be made as high as 40 db, however, in fixed-frequency circuits.

The Twin-Triode Mixer The mixer circuit shown in figure 26 has about 10 db lower distortion than the conventional 6BE6 converter tube. It has a lower voltage gain of about unity and a lower output impedance which loads the first tuned circuit and reduces its selectivity. In some applications the lower gain is of no consequence but the lower distortion level is important enough to warrant its use in high performance equipment. The signal-to-distortion ratio of this mixer is of the order of 70 db compared to approximately 60 db for a 6BE6 mixer when the level of each of two tone signals is 0.5 volt. With stronger signals, the 6BE6 distortion increases very rapidly, whereas the 12AU7 distortion is comparatively much better.

In practical equipment where the injection frequency is variable and trimming adjustments and tube selection cannot be used, it may be easier and more economical to obtain this extra 20 db of attenuation by using an extra tuned circuit in the output than by using a balanced modulator circuit. Two balanced modulator circuits of interest are shown in figure 27, providing a minimum of 20 db of carrier attenuation.

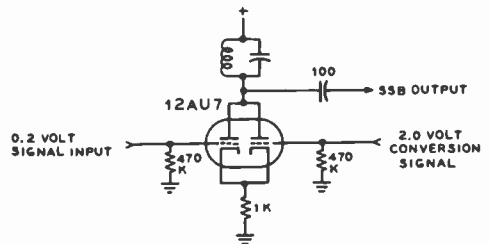

Figure 26

TWIN-TRIODE MIXER CIRCUIT FOR SSB FREQUENCY CONVERSION

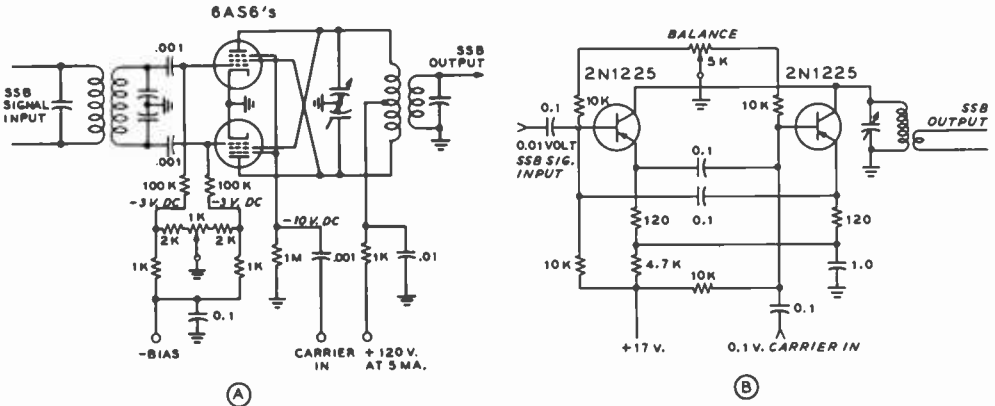

Figure 27

BALANCED MODULATOR CIRCUITS FOR SSB FREQUENCY CONVERSION

A is a balanced modulator using 6AS6 tubes with screen elements cross-connected for maximum carrier suppression. Bias potentiometer allows adjustment for variation in tube parameters. B is a transistor balanced modulator. Balance is achieved by varying the base bias on the 2N1225 transistors.

Selective Tuned Circuits The selectivity requirements of the tuned circuits following a mixer stage often become quite severe. For example, using an input signal at 250 kHz and a conversion injection frequency of 4000 kHz the desired output may be 4250 kHz. Passing the 4250-kHz signal and the associated sidebands without attenuation and realizing 100 db of attenuation at 4000 kHz (which is only 250 kHz away) is a practical example. Adding the requirement that this selective circuit must tune from 2250 to 4250 kHz further complicates the basic requirement. The best solution is to cascade a number of tuned circuits. Since a large number of such circuits may be required, the most practical solution is to use permeability tuning, with the circuits tracked together. An example of such circuitry is found in the *Collins 32S* sideband transmitter.

If an amplifier tube is placed between each tuned circuit, the over-all response will be the sum of one stage multiplied by the number of stages (assuming identical tuned circuits). Figure 28 is a chart which may be used to determine the number of tuned circuits required for a certain degree of attenuation at some nearby frequency. The Q of the circuits is assumed to be 50, which is

normally realized in small permeability-tuned coils. The number of tuned circuits with a Q of 50 required for providing 100 db of attenuation at 4000 kHz while passing 4250 kHz may be found as follows:

$$\Delta f \text{ is } 4250 - 4000 = 250 \text{ kHz}$$

where,

$$f_r \text{ is the resonant frequency (4250 kHz),}$$

and,

$$\frac{\Delta f}{f_r} = \frac{250}{4250} = 0.059$$

The point on the chart where .059 intersects 100 db is between the curves for 6 and 7 tuned circuits, so 7 tuned circuits are required.

Another point which must be considered in practice is the tuning and tracking error of the circuits. For example, if the circuits were actually tuned to 4220 kHz instead of

$$4250 \text{ kHz, the } \frac{\Delta f}{f_r} \text{ would be } \frac{220}{4220} \text{ or}$$

0.0522. Checking the curves shows that 7 circuits would just barely provide 100 db of attenuation. This illustrates the need for very accurate tuning and tracking in circuits having high attenuation properties.

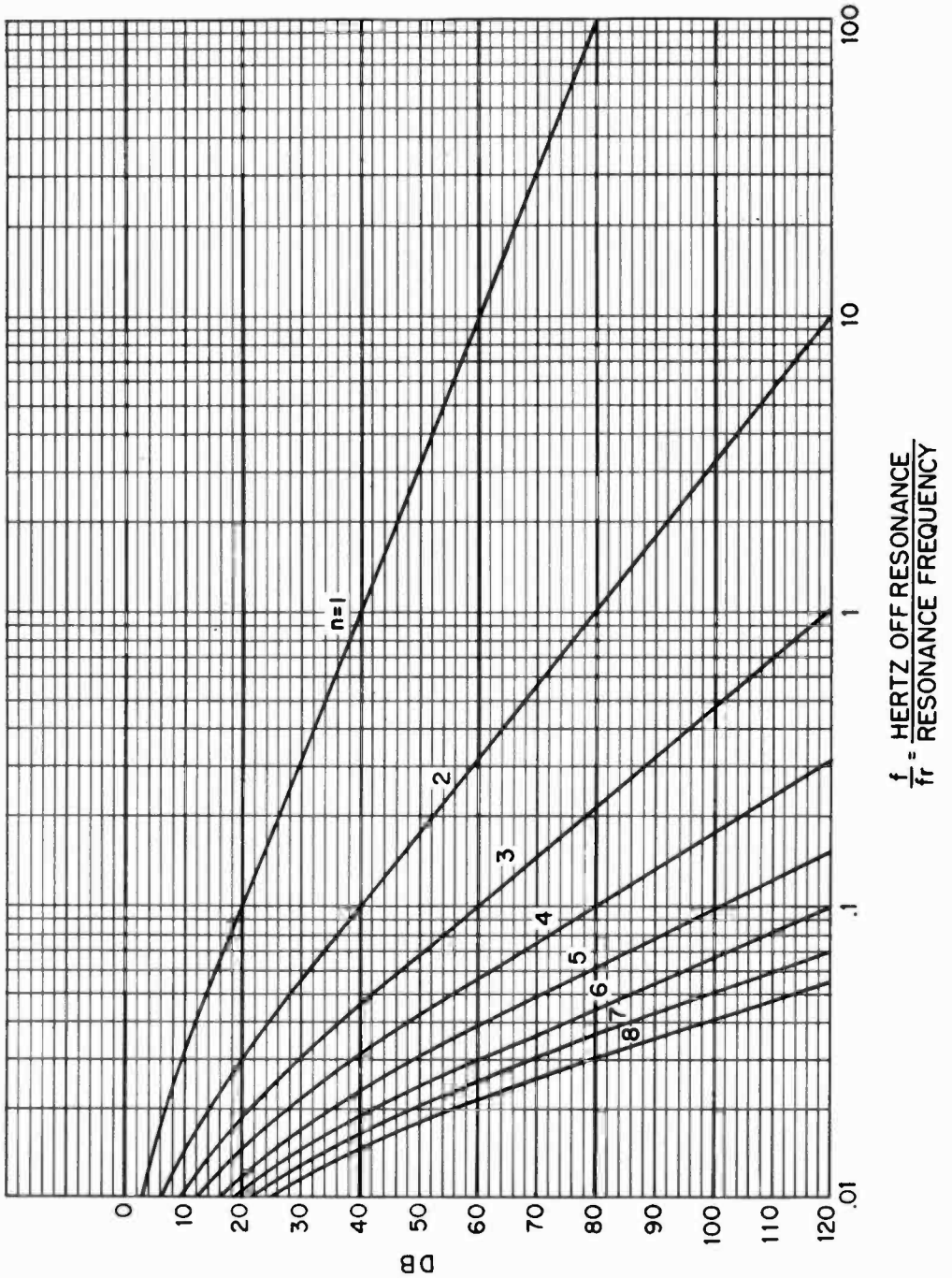

Figure 28

RESPONSE OF "N" NUMBER OF TUNED CIRCUITS,
ASSUMING EACH CIRCUIT Q IS 50

Coupled Tuned Circuits When as many as 7 tuned circuits are required for proper attenuation, it is not necessary to have the gain that 6 isolating amplifier tubes would provide. Several vacuum tubes can be eliminated by using two or three coupled circuits between the amplifiers. With a coefficient of coupling between circuits 0.5 of critical coupling, the over-all response is very nearly the same as isolated circuits. The gain through a pair of circuits having 0.5 coupling is only eight-tenths that of two critically coupled circuits, however. If critical coupling is used between two tuned circuits, the nose of the response curve is broadened and about 6 db is lost on the skirts of each pair of critically coupled circuits. In some cases it may be necessary to broaden the nose of the response curve to avoid adversely affecting the frequency response of the desired passband. Another tuned circuit may be required to make up for the loss of attenuation on the skirts of critically coupled circuits. In some cases it may be necessary to broaden the nose of the response curve to avoid adversely affecting the frequency response of the desired passband. Another tuned circuit may be required to make up for the loss of attenuation on the critically coupled circuits.

Frequency-Conversion Problems The example in the previous section shows the difficult selectivity problem encountered when strong undesired signals appear near the desired frequency. A high-frequency SSB transmitter may be required to operate at any carrier frequency in the range of 1.7 to 30 MHz. The problem is to find a practical and economical means of heterodyning the generated SSB frequency to any carrier frequency in this range. There are many modulation products in the output of the mixer and a frequency scheme must be found that will not have undesired output of appreciable amplitude at or near the desired signal. When tuning across a frequency range some products may "cross over" the desired frequency. These undesired crossover frequencies should be at least 60 db below the desired signal to meet modern standards. The amplitude of the undesired products depends on the particular characteristics of the mixer and the particu-

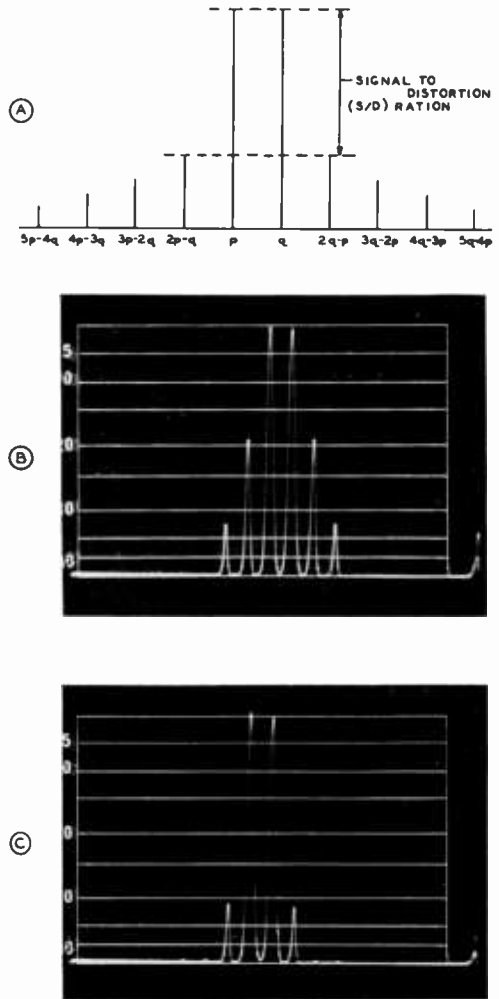

Figure 29

A shows SSB distortion products pictured up to ninth order. B shows SSB distortion products as seen on a panoramic analyzer. Third-order products are 19 decibels below two-tone test signal and fifth-order products are 32 decibels below the test signal. C illustrates that third-order products are about 31 decibels below test signal and higher-order products are better than 40 decibels down from test signal.

lar order of the product. In general, most products of the 7th order and higher will be at least 60 db down. Thus any crossover frequency lower than the 7th order must be avoided since there is no way of attenuating them if they appear within the desired passband. The book *Single Sideband Principles*

R-F LINEAR AMPLIFIER SERVICE FOR SSB AND CW													
GRID DRIVEN, CLASS AB ₁ MODE													
TUBE	FIL $\frac{V}{A}$	BASE	PLATE VOLTAGE E_b	SCREEN VOLTAGE E_{c2}	GRID VOLTAGE E_{c1}	ZERO SIG. PLATE CUR. I_{b0}	MAX. SIG. PLATE CUR. I_b	MAX. SIG. SCREEN CUR. I_{c2}	PL. LOAD IMPEDAN $R_p - \Omega$	PLATE INPUT PWR. W	USEFUL POWER OUT. P_o	AVERAGE PLATE DISSIP. P_d	3d ORDER IMD Db
6146	6.3	7CK	600	200	-46	25	103	9	3570	61	41	16	-25
6146B	1.2		750	200	-51	25	118	7	2825	88	55	28	-22
			800	290	-89	30	125	10	3620	100	59	35	-24
			800	290	-77	25	180	13	2300	145	91	45	-19
807	6.3	5AW	600	300	-34	18	70	8	4300	42	28	12	-23
	0.9		750	300	-35	15	70	8	5200	53	36	14	-23
6550	6.3	7S	680	340	-39	48	140	20	3010	95	67	26	-32
	1.6		800	290	-33	45	127	15	3920	102	70	29	-30
6DQ5	6.3	8JC	500	150	-46	48	170	17	1800	65	54	27	-28
	2.5		500	150	-46	48	182	13	1825	91	56	29	-26
			700	150	-49	35	182	11	2210	127	78	41	-23
			800	180	-67	30	250	13	1710	200	121	70	-19
6GB5		6.3	9NH	600	200	-41	23	192	14	1900	115	80	30
	1.36												
6GE5	6.3	12BJ	600	200	-45	30	132	15	2500	79	51	23	-22
	1.2		800	250	-61	25	172	18	2750	138	90	39	-19
6HF5	6.3	12FB	500	140	-46	40	133	5	1900	67	35	29	-27
	2.25		800	125	-45	30	197	7	2170	158	100	46	-21
6JE6A	6.3	9QL	500	125	-44	40	110	4	2300	55	30	24	-28
	2.5		750	175	-63	27	218	15	1850	163	102	51	-20
6LQ6	6.3	9QL	750	175	-60	25	215	9	1850	161	102	49	-18
	2.5		800	200	-69	25	242	13	1850	197	124	60	-18

Figure 30
SWEEP TUBE DATA FOR CLASS AB₁ LINEAR AMPLIFIER SERVICE

and Circuits by Pappenfus, McGraw Hill Book Co., Inc., N. Y., covers the subject of spurious products and incorporates a "mix selector" chart that is useful in determining spurious products for various different mixing schemes.

In general, for most applications when the intelligence-bearing frequency is lower than the conversion frequency, it is desirable that the ratio of the two frequencies be between 5 to 1 and 10 to 1. This a compromise between avoiding low-order harmonics of this signal input appearing in the output, and minimizing the selectivity requirements of the circuits following the mixer stage.

16-7 Distortion Products Due to Nonlinearity of R-F Amplifiers

When the SSB envelope of a *voice* or *multi-tone* signal is distorted, a great many new frequencies are generated. These represent all of the possible combinations of the sum and difference frequencies of all harmonics of the original frequencies. For purposes of test

and analysis, a *two-tone* test signal (two equal-amplitude tones) is used as the SSB source. Since the SSB radio-frequency amplifiers use tank circuits, all distortion products are filtered out except those which lie close to the desired frequencies. These are all odd-order products; third order, fifth order, etc. The third-order products are $2p - q$ and $2q - p$ where p and q represent the two SSB r-f tone frequencies. The fifth order products are $3p - 2q$ and $3q - 2p$. These and some higher order products are shown in figure 29 A, B, and C. It should be noted that the fre-

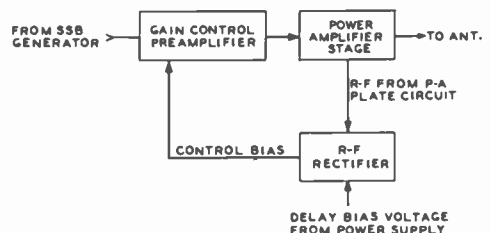

Figure 31

BLOCK DIAGRAM OF AUTOMATIC LOAD CONTROL (A.L.C.) SYSTEM

quency spacings are always equal to the difference frequency of the two original tones. Thus when an SSB amplifier is badly overloaded, these spurious frequencies can extend far outside the original channel width and cause an unintelligible "splatter" type of interference in adjacent channels. This is usually of far more importance than the distortion of the original tones with regard to intelligibility or fidelity. To avoid interference in another channel, these distortion products should be down at least 30 db below the adjacent channel signal. Using a two-tone test, the distortion is given as the ratio of the amplitude of one test tone to the amplitude of a third-order product. This is called the *signal-to-distortion ratio* (S/D) and is usually given in decibels. The use of feedback r-f amplifiers make S/D ratios of greater than 40 db possible and practical.

Vacuum-Tube Nonlinearity Distortion products caused by amplifier departure from a linear condition are termed *intermodulation products* and the distortion is termed *intermodulation distortion*. This distortion can be caused by nonlinearity of amplifier gain or phase shift with respect to input level, and only appears when a multi-tone signal is used to drive the linear amplifier. This is the case for a voice signal which is composed of many tones, and intermodulation distortion will show up as a "gravelly" tone on the voice and will create interference to signals on adjacent channels. The main source of intermodulation distortion in a linear amplifier is the vacuum tube or transistor as these components have inherently nonlinear characteristics. Maximum linearity may be achieved by proper choice of tube or transistor and their operating conditions.

A practical test of linearity is to employ a two-tone, low-distortion signal to drive the tube or transistor and to use a spectrum analyzer to display a sample of the output spectrum on an oscilloscope (figure 29). The test signal, along with spurious intermodulation products may be seen on the screen, separated on the horizontal axis by the difference in frequency between the two tones. A reading is made by comparing the amplitude of a specific intermodulation product with the amplitude of the test signal. For

convenience, the ratio between one of the test signals and one of the intermodulation products is read as a power ratio expressed in decibels below the test signal level. Measurements made on a number of power tubes have shown typical intermodulation distortion levels in the range of -20 to -40 decibels below one tone of a two-tone test signal.

The present state of the art in commercial and military SSB equipment calls for third-order intermodulation products better than -40 to -60 decibels below one tone of a two-tone test signal. Amateur requirements are less strict, running as low as -20 decibels, and may be justified on an economic basis since signal distortion, at least to the listener, is a highly subjective thing. To date, the use of inexpensive TV-type sweep tubes as linear amplifiers in amateur SSB gear has been acceptable, regardless of the rather high level of distortion inherent in these tube types.

Listed in the chart of figure 30 are intermittent voice operation ratings for various sweep tubes used for linear operation in the amateur service. While the plate dissipation of these tubes is of the order of 30 watts or so, the intermittent nature of amateur transmission and the high ratio of peak to average power in the human voice allow a good balance between power input, tube cost and tube life. For lower levels of intermodulation distortion, the user must shift to transmitting-type tubes rated for linear service, and which are designed to have low intermodulation-distortion characteristics.

16-8 Automatic Load Control and Speech Compression

Several means may be used to keep the amplitude of distortion products down to acceptable levels and yet provide a high average degree of modulation. One method is to design the amplifier for excellent linearity over the expected amplitude or power range. A second method is to employ audio compression to ensure that high amplitude peaks are suitably restricted before they cause trouble. The third method is to limit the amplitude of the SSB envelope by em-

playing an r-f driven source of compression termed *automatic load control* (ALC)

It should be noted that the r-f wave shapes of the SSB signal are always sine waves because the tank circuits make them so. It is the change in gain or phase with signal level in an amplifier that distorts the SSB envelope and generates unwanted distortion products. An ALC system may be used to limit the input signal to an amplifier to prevent a change in gain level caused by excessive input level.

The ALC system is adjusted so the power amplifier is operating near its maximum power capability and at the same time is protected from being over-driven.

In amplitude-modulated systems it is common to use speech compressors and speech clipping systems to perform this function. These methods are not equally useful in SSB. The reason for this is that the SSB envelope is different from the audio envelope and the SSB peaks do not necessarily correspond with the audio peaks as explained earlier in this chapter. For this reason an r-f compressor of some sort located between the SSB generator and the power amplifier is most effective because it is controlled by SSB envelope peaks rather than audio peaks. Such an "SSB signal compressor" and the means of obtaining its control voltage comprise a satisfactory ALC system.

The ALC Circuit A block diagram of an ALC circuit is shown in figure 31. The compressor or gain control part of this circuit uses one or two stages of remote cutoff tubes such as 6BA6, operating

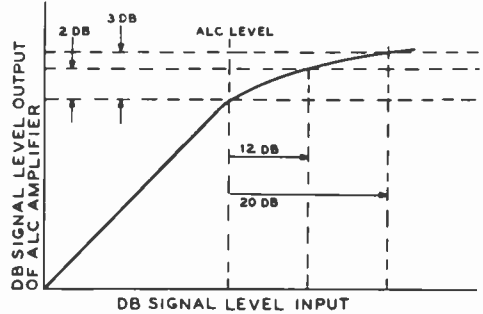

Figure 32
PERFORMANCE CURVE OF ALC CIRCUIT

very similarly to the intermediate-frequency stages of a receiver having automatic volume control.

The grid bias voltage which controls the gain of the tubes is obtained from a voltage detector circuit connected to the power amplifier tube plate circuit. A large delay bias is used so that no gain reduction takes place until the signal is nearly up to the full power capability of the amplifier. At this signal level, the rectified output overcomes the delay bias and the gain of the preamplifier is reduced rapidly with increasing signal so that there is very little rise in output power above the threshold of gain control.

When a signal peak arrives that would normally overload the power amplifier, it is desirable that the gain of the ALC amplifier be reduced in a few milliseconds to a value where overloading of the power amplifier is overcome. After the signal peak passes, the

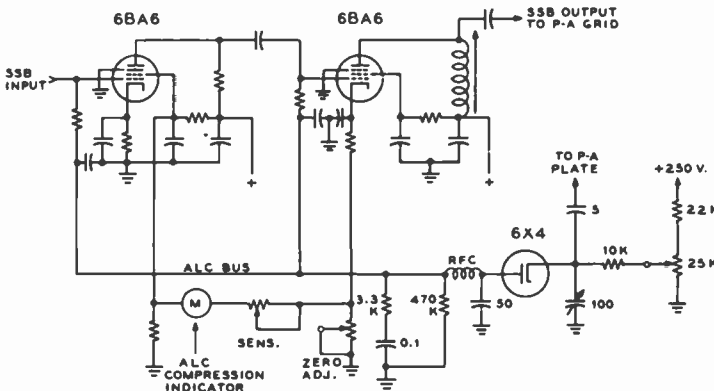

Figure 33
SIMPLIFIED SCHEMATIC OF AUTOMATIC LOAD CONTROL AMPLIFIER. OPERATING POINT OF ALC CIRCUIT MAY BE SET BY VARYING BLOCKING BIAS ON CATHODE OF 6X4 SIGNAL RECTIFIER

gain should return to the normal value in about one-tenth second. These attack and release times are commonly used for voice communications. For this type of work, a dynamic range of at least 10 db is desirable. Input peaks as high as 20 db above the threshold of compression should not cause loss of control although some increase in distortion in the upper range of compression can be tolerated because peaks in this range are infrequent. Another limitation is that the preceding SSB generator must be capable of passing signals above full power output by the amount of compression desired. Since the signal level through the SSB generator should be maintained within a limited range, it is unlikely that more than 12 db ALC action will be useful. If the input signal varies more than this, a speech compressor should be used to limit the range of the signal fed into the SSB generator.

Figure 32 shows the effectiveness of the ALC in limiting the output signal to the capabilities of the power amplifier. An adjustment of the delay bias will place the threshold of compression at the desired power output. Figure 33 shows a simplified schematic of an ALC system. This ALC uses two variable-gain amplifier stages and the maximum over-all gain is about 20 db. A meter is incorporated which is calibrated in db of compression. This is useful in adjusting the gain for the desired amount of load control. A capacitance voltage divider is used to step down the r-f voltage at the plate of the amplifier tube to about 50 volts

for the ALC rectifier. The output of the ALC rectifier passes through RC networks to obtain the desired attack and release times and through an r-f filter capacitor. The 3.3K resistor and 0.1- μ fd capacitors across the rectifier output stabilize the gain around the ALC loop to prevent "motorboating" (instability).

An effective grid-derived ALC system is shown in figure 34. Minute fluctuations in grid current occur in tetrodes as the grid is driven to zero potential and these fluctuations are rectified and filtered to provide an ALC signal which may be applied to a remote-cutoff tube in an earlier stage of the exciter.

Speech Compression The human voice is characterized by a rather high ratio of peak-to-average power. Since any SSB transmitter has a definite peak-power capacity, which should not be exceeded, a reduction in the ratio of peak-to-average power levels allows an increase in the average power transmitted. Reduction in this ratio may be accomplished by ALC systems or by audio-derived speech compression. A simple speech compressor is a form of automatic variable gain amplifier whose output signal bears some consistent relationship to the input and which is controlled by a feedback loop which samples the output signal of the compressor. The sample signal is rectified and the resulting d-c control voltage is applied to a preceding gain-controlled stage. The time constants of this type of circuit are slow in order to prevent oscillation and distortion.

A practical speech compressor which may be added ahead of the speech system of an SSB transmitter is shown in figure 35. A 2N3819 FET-type transistor is used as the input stage to provide a high-impedance termination for a crystal microphone. The second stage is a 2N2925 whose output load is divided between the emitter and the collector. Stage gain may be varied by controlling the emitter-to-ground impedance. A third 2N2925 amplifier provides the output signal from the compressor and also feeds the audio signal to a rectifier-filter system which provides an amplified syllabic-varying d-c feedback voltage to the second-stage transistor. The last stage acts as a

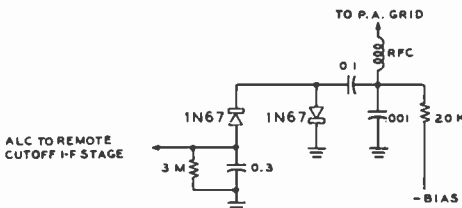

Figure 34

GRID-DERIVED ALC CIRCUIT

Minute fluctuations in grid current caused by driving tetrode tube to zero bias point are rectified, filtered, and applied to low-level i-f stage having a remote-cutoff pentode tube. ALC level is set by applying delay bias to diode rectifiers.

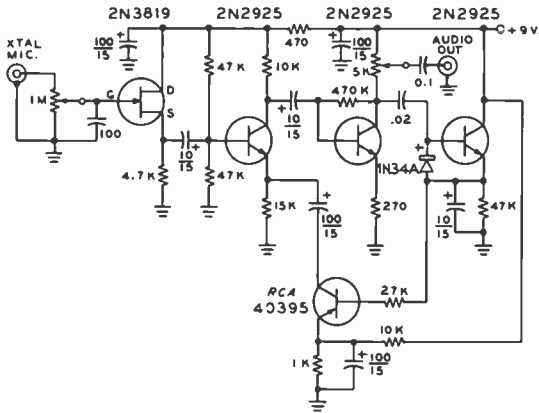

Figure 35

FET SPEECH COMPRESSOR-AMPLIFIER FOR SSB

This five-stage transistor compressor/amplifier may be added between a crystal microphone and an existing speech amplifier. Compression is achieved by applying rectified signal voltage to the emitter of the second amplifier stage. Stage gain is thus controlled by varying the emitter-to-ground impedance. Compression is adjusted by control of speech-amplifier gain in transmitter and the setting of input gain in the compressor amplifier. Maximum compression is about 30 decibels, and up to 15 decibels or so may be used to advantage without undue distortion of the voice.

current-sensitive variable resistor effectively in series with the emitter bypass capacitor of the 2N2925 amplifier, changing the gain of this stage as the resistance of the third transistor changes. Compression starts to take place at an input level of about 1 millivolt, holding the output substantially constant up to an input level of about 35 millivolts. Output level is about 200 millivolts and the maximum compression range is over 30 decibels.

Experience "on the air" with speech compression has proven its usefulness, especially when no provisions for automatic load control are incorporated in the transmitter. To achieve maximum effectiveness and signal "punch", it has been found that attenuation of the lower-frequency voice tones is of great benefit under conditions of high compression. A compression level of about 14 decibels, coupled with smooth and gradual attenuation of speech frequencies below 500 Hz or so provides excellent intelligibility to the SSB signal. Low-frequency audio attenuation may be achieved by tailoring the audio response of the transmitter; however, an easier approach is to employ a microphone having controlled low-frequency attenuation, such as the *Electro-Voice* model 676. A three-position switch on the microphone permits adjustment of low-frequency rolloff and that degree of attenuation best suited to the operator's voice may be chosen by experiment. The combination of a simple speech compressor and controlled-frequency-

response microphone are worthwhile adjuncts to any sideband operator wishing to achieve maximum transmission efficiency from his station.

16-9 Basic SSB Exciters

Several basic filter and phasing-style exciter circuits exist which are the foundation of the majority of amateur SSB exciters. One of the best known of these interesting circuits is the so-called *SSB Junior*. Employing only three tubes, this phasing unit is a classic example of single-sideband generation reduced to its simplest form.

The SSB, Jr. This little phasing exciter employs audio and r-f phasing circuits to produce an SSB signal at one spot frequency. The complete circuit is shown in figure 36.

The first tube, a 12AU7, is a twin triode serving as a speech amplifier and a crystal oscillator. The second tube is a 12AT7, acting as a twin-channel audio amplifier following the phase-shift audio network. The linear amplifier stage is a 6AG7, capable of a peak power output of 5 watts.

Sideband switching is accomplished by the reversal of audio polarity in one of the audio channels (switch S_1), and provision is made for equalization of gain in the audio channels (R_{12}). This adjustment is necessary in order to achieve normal sideband cancellation,

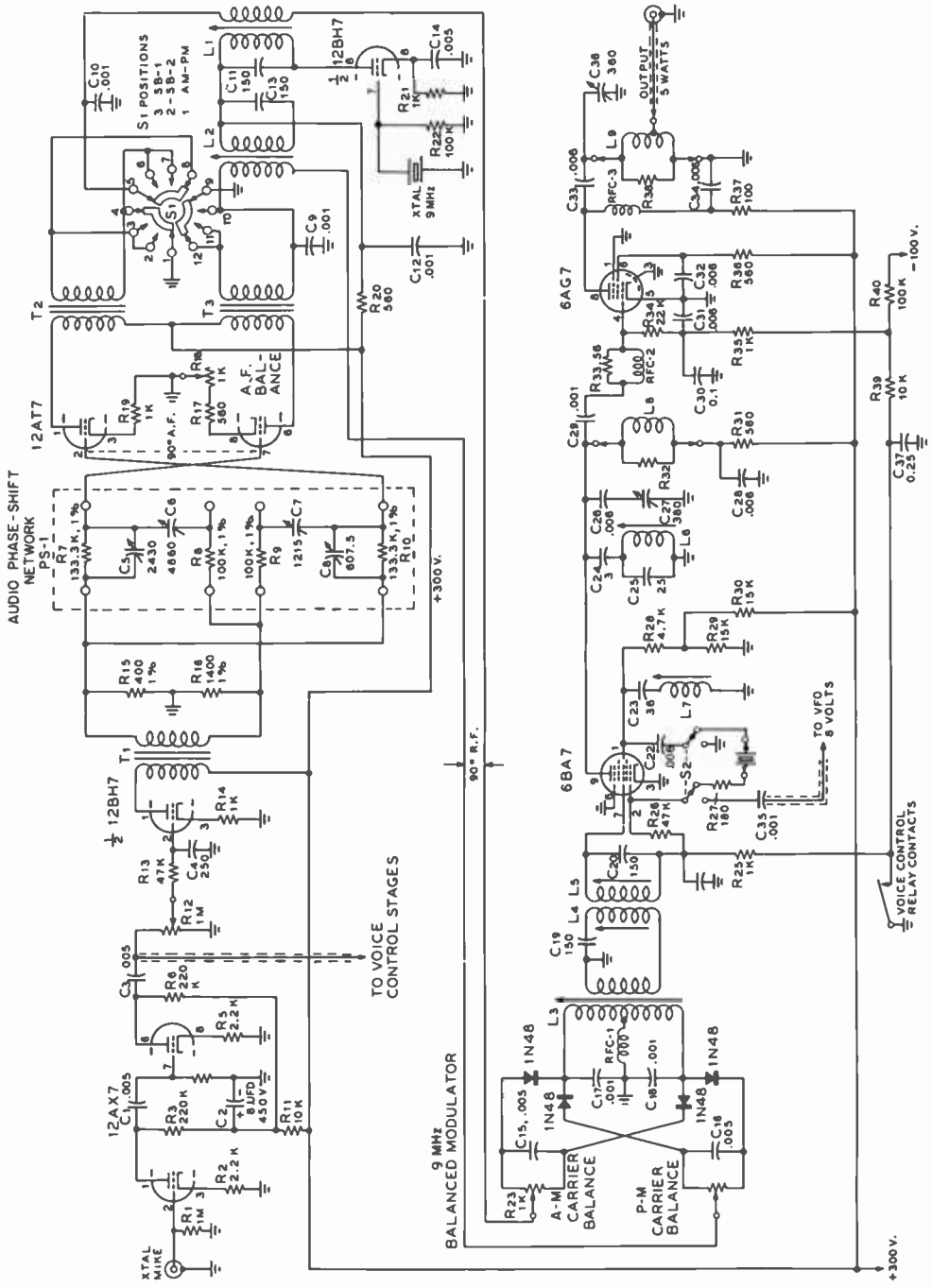

Figure 37

SIMPLIFIED SCHEMATIC OF "TEN-A" EXCITER

signal is amplified in a 6AG7 linear amplifier stage. Two "tweet" traps are incorporated in the 6BA7 stage to reduce unwanted responses of the mixer which are apparent when the unit is operating in the 14-MHz band. Band changing is accomplished by changing coils L_4 and L_5 and the frequency of the external mixing signal. Maximum power output is of the order of 5 watts at any operating frequency.

A Transistorized SSB Filter Exciter A transistorized SSB filter exciter is illustrated in Figure 38. It is designed for operation in the 2- to 30-MHz range and makes use of a 9-MHz crystal filter. A GE-1 transistor crystal oscillator provides the carrier for the balanced modulator via a link-coupled circuit. Capacitive and resistive carrier-balance controls provide over 30 decibels carrier suppression. The balanced modulator is of the configuration shown in Figure 20. A two-stage speech amplifier provides ample gain for use of a

low-impedance dynamic microphone. Audio gain is controlled by varying the base bias on the second speech amplifier stage.

The 9-MHz SSB signal from the filter is beat to the desired operating frequency in a transistor mixer stage. Typical r-f voltages in the mixer stage are indicated in the schematic. The collector of the mixer is tapped down on the output tank circuit to provide optimum impedance match. Output of the mixer stage is about 0.1 volt.

Selection of the upper or lower sideband is accomplished by placing the carrier oscillator on the proper slope of the sideband filter. The oscillator should be set at approximately the 20-decibel suppression point of the passband for best operation. If the oscillator is closer in frequency to the filter passband than this, carrier rejection will suffer. If the oscillator is moved further away in frequency from the passband, the lower voice frequencies will be attenuated and the SSB signal will sound high-pitched and tinny. The two carrier-balance controls are adjusted for

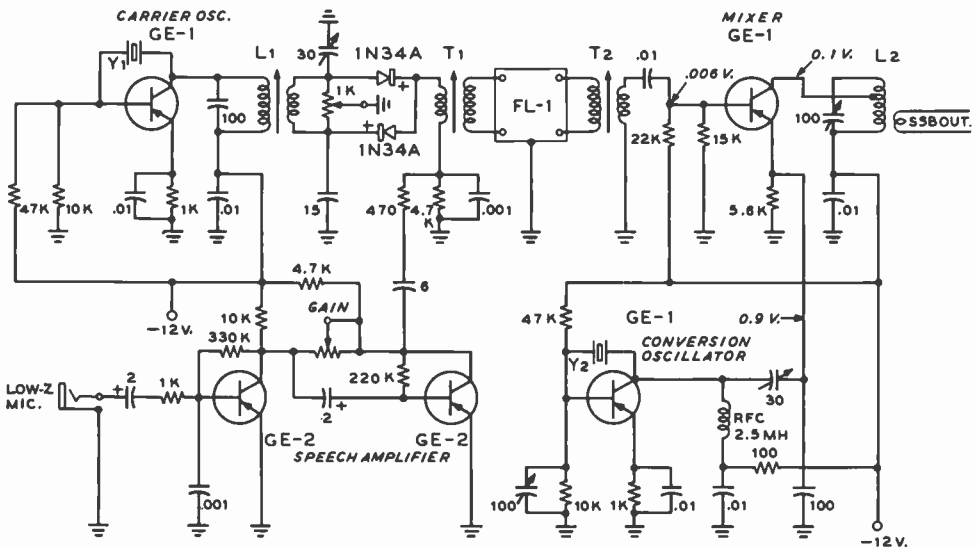

Figure 38

TRANSISTOR SSB EXCITER USING 9-MHz CRYSTAL FILTER

This simple SSB exciter employs "entertainment-type" transistors and a packaged 9-MHz crystal filter. Transistors are General Electric types. Transformers T₁ and T₂ may be supplied by filter manufacturer and vary according to filter design. Selection of sideband is accomplished by choice of crystal oscillator frequency, placing the carrier oscillator crystal (Y₁) on the proper slope of the sideband filter.

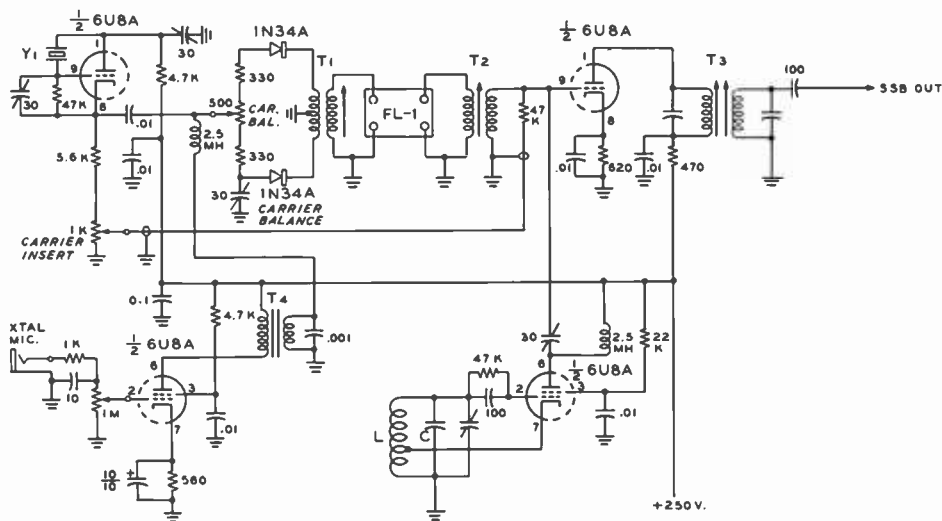

Figure 39

TWO-TUBE FILTER-TYPE SSB EXCITER

Simple two-tube exciter illustrates basic principles of filter technique. First 6U8A serves as carrier oscillator and speech amplifier. Second 6U8A serves as mixer and local h-f oscillator. Choice of filter and oscillator frequencies depend on the frequency of the desired SSB signal. Sideband selection is accomplished by placing carrier-oscillator crystal frequency on the proper slope point of the sideband filter.

a carrier null indication on the S meter of a receiver coupled to the output of the sideband filter.

A crystal is now placed in the conversion oscillator and proper operation is checked by monitoring the conversion frequency with the nearby receiver. The mixer stage is finally adjusted for maximum output at the desired frequency.

A Two-Tube SSB Exciter A "basic" two-tube SSB exciter is shown in figure 39. Depending upon the frequency of the sideband filter, the exciter may be used on any amateur band between 160 and 6 meters. A 6U8A is used as a combined carrier oscillator and speech amplifier. The audio and r-f signals are combined in a double-diode modulator having resistive and capacitive balance controls. The filter (FL-1) and coupling transformers may be purchased as a package and a common choice of filter frequency falls in the range between 5 MHz and 9MHz. For 6-meter operation, a 10.7 MHz crystal filter is often used.

The single sideband selected by the filter is converted to the chosen operating range in a 6U8A combined mixer/oscillator stage. The triode section of the 6U8A is used as a grid-injection mixer and the tetrode section is employed as an electron-coupled oscillator, whose frequency is determined by the difference frequency between the filter passband and the output frequency of the exciter. Generally speaking, for minimum "birdie" problems, the mixing oscillator is placed on the high-frequency side of the output frequency for the lower-frequency bands, and on the low-frequency side of the output frequency for the 20-, 15- and 10-meter bands.

Selection of sideband is done by placing the carrier oscillator crystal Y_1 on the proper side of the sideband filter passband. Output of the h-f mixer stage is of the order of 3 to 5 volts, peak; sufficient to drive a 6CL6 or 6GK6 tetrode to several watts output. For best frequency stability, the high voltage to the oscillator stages should be voltage regulated, particularly on the higher-frequency bands.

16-10 SSB Reception

Single-sideband reception may be considered the reverse of the process used in SSB transmission. The received SSB signal is amplified, translated downward in frequency, further amplified and converted into a replica of the original audio frequencies. The SSB receiver is invariably a superheterodyne in order to achieve high sensitivity and selectivity.

To recover the intelligence from the SSB signal, it is necessary to restore the carrier in such a way as to have the same relationship with the sideband components as the original carrier generated in the SSB exciter. To achieve this, it is important that the receiver oscillators have good frequency accuracy and stability.

To take advantage of the narrow bandwidth occupied by the SSB signal, selectivity characteristics of the receiver must be held to narrow limits. Excessive receiver bandwidth degrades the signal by passing unnecessary interference and noise.

SSB Receivers In a conventional a-m receiver, the audio intelligence is recovered from the radio signal by an envelope amplitude detector, such as a diode rectifier. This technique may be used to recover the audio signal from an SSB transmission provided the amplitude of the local carrier generated by the beat oscillator is sufficiently high to hold audio distortion at a reasonable low level. Better performance with respect to distortion may be achieved if a *product detector* is used to recover the audio signal.

The characteristics of the *automatic volume control* (or *automatic gain control*) system of an SSB receiver differ from those of a conventional a-m receiver. In the latter, the agc voltage is derived by rectifying the received carrier, as the carrier is relatively constant and does not vary rapidly in amplitude. The agc system can therefore have a rather long time constant so that an S-meter may be used to indicate relative carrier amplitude.

In an SSB receiver, however, the signal level varies over a large range at a syllabic rate and a fast time-constant agc system is required to prevent receiver overload on

initial bursts of a received signal. To prevent background noise from receiving full amplification when the SSB signal is weak or absent, a relatively slow agc release time is required.

The agc system, moreover, must be isolated from the local-oscillator voltage to prevent rectification of the oscillator voltage from placing an undesired no-signal static bias voltage on the agc line of the receiver.

Thus, the SSB receiver differs from the a-m receiver in that it requires a higher order of oscillator stability and i-f bandwidth, a more sophisticated agc system, and the capability of receiving signals over a very wide range of strength without overload or cross modulation. In addition, the tuning rate of the SSB receiver should be substantially less than that of an a-m receiver; generally speaking, tuning rates of 25 to 100 kHz per dial revolution are common in modern SSB receivers.

Because of variations in the propagation path, transmitter power, and distance between stations, the input signal to an SSB receiver can vary over a range of 120 decibels or so. The receiver requires, therefore, a large dynamic range of signal-handling capability and an enhanced degree of gain-adjusting capability.

SSB Receiver Circuitry For minimum spurious response it is desired to have good selectivity ahead of the amplifier stages in the SSB receiver. This is possible to a degree, provided circuit simplicity and receiver sensitivity are not sacrificed. For the case when sensitivity is not important, an attenuator may be placed in the receiver input circuit to reduce the amplitude of strong, nearby signals (figure 40). To further reduce the generation of cross-modulation interference, it is necessary to carefully select the tube type used in the r-f amplifier stage to determine if it will retain its linearity with the application of agc-bias control voltage. Suitable r-f stage circuits are shown in the *Radio Receiver Fundamentals* chapter of this Handbook.

Avoidance of images and spurious responses is a main problem in the design of SSB receiver mixers. Due to the presence of harmonics in the mixer/oscillator signal and nonlinearity in the mixer, higher-order prod-

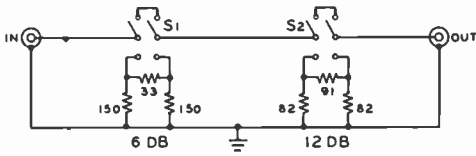

Figure 40

R-F ATTENUATOR FOR SSB RECEIVER

The dynamic signal range of an SSB receiver may be increased, and troubles resulting from overload may be decreased with the use of a simple r-f attenuator placed in the coaxial line from the antenna to the receiver. This attenuator is designed for use with either 50- or 70-ohm transmission lines and may be built in a small aluminum Minibox.

ucts are generated in addition to the desired mixing product. These undesired products vary in frequency as the oscillator is tuned and may fall within the received passband, creating *crossovers*, or *birdies* (spurious beatnotes which tune faster than the normal tuning rate).

Choice of an intermediate frequency low with respect to signal frequency minimizes the probability of strong birdie signals within the receiver passband. The low intermediate frequency, however, may lead to image problems at the higher received frequencies.

The twin problems of images and crossovers can be resolved through the use of double conversion. The first (high) conversion provides adequate image rejection and the second (low) conversion may be adjusted so as to reduce crossover points to a minimum. In addition, double conversion allows the use of a crystal-controlled oscillator for the first converter stage, which can provide a higher order of stability than a tunable oscillator. The oscillator for the lower mixer stage may be made tunable, covering only a single frequency range, eliminating some of the mechanical and electrical factors contributing to receiver instability.

The bandwidth of the low-frequency i-f system determines the over-all selectivity of the SSB receiver. For SSB voice reception, the optimum bandwidth at the 6-db point is about 2 kHz to 3 kHz. It is good practice to place the selective filter in the circuit ahead of the i-f amplifier stages so that strong adjacent-channel signals are attenuated

before they drive the amplifier tubes into the overload region. In addition to the sideband filter, additional tuned circuits are usually provided to improve over-all receiver selectivity, especially at frequencies which are down the skirt of the selectivity curve. Some types of SSB filters have spurious responses outside the passband which can be suppressed in this manner.

Automatic Gain Control and Signal Demodulation The function of an automatic gain control system is to reduce the gain of the controlled stages on signal peaks to prevent receiver overload and hold constant audio output. Since the carrier is not transmitted in SSB, the receiver agc system must obtain its signal voltage from the modulation envelope. The agc voltage may be derived either from the i-f signal or the audio signal (figure 41). Audio-derived agc has the advantage of easier isolation from the local carrier voltage, but the i-f system will function on both SSB and a-m signals in a satisfactory manner.

Product detectors are preferred for SSB reception because they minimize intermodu-

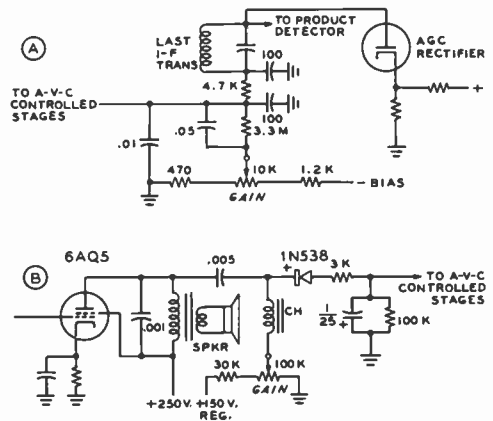

Figure 41

R-F AND A-F DERIVED AGC CIRCUITS

A—Control voltage is derived from r-f signal by agc rectifier placed at end of i-f strip. Threshold gain is set by adjustment of negative bias on the plate of the agc rectifier. B—Control voltage is derived from audio signal taken from output stage of receiver. Threshold gain is set by diode bias applied through low-resistance audio inductance (CH).

lation distortion products in the audio signal and, in addition, do not require a large local-oscillator voltage. The product detector also affords a high degree of isolation between the carrier oscillator and the agc circuit. The undesired mixing products present in the output circuit of the detector may be suppressed by a low-pass filter placed in the audio line.

Product detectors may take the form of mixer stages, as discussed in a previous chapter. Two simple diode product detectors are shown in figure 42. These are of the same form as the diode modulators shown earlier in this Chapter.

Two vacuum-tube product detectors are shown in figure 43. Illustration A shows a 6BE6 multigrid mixer tube functioning as a combined product detector and beat oscillator. The SSB signal is applied to the control grid of the tube and the #1, #2, and #4 grids, and the cathode element form the triode oscillator. Mixing takes place within the tube, since the cathode current of the tube is controlled by the simultaneous action of the two signals and contains frequencies equal to the sum and difference between the sideband signal and the local carrier signal. The desired audio signal is recovered across the plate resistor of the tube and other unwanted signals are suppressed by the low pass r-f filter in the plate circuit of the stage.

A low-distortion product detector is shown in figure 43B using a 6AS6 dual-grid pentode tube. The SSB signal is injected on one grid and the external local-oscillator signal is injected on the second grid. A portion of the signal is rectified by a small diode to provide ALC control voltage and an S-meter is placed between the 6AS6 cathode and the cathode of the last controlled i-f amplifier stage. The ALC time constant may be adjusted by switch S₁. Another popular product detector resembles the mixer shown in figure 26.

An interesting development in the single-sideband field is the *beam-deflection tube* (type 7360). This miniature tube employs a simple electron "gun" which generates, controls, and accelerates a beam of electrons directed toward identical plates. The total plate current is determined by the voltages applied to the control grid and screen grid

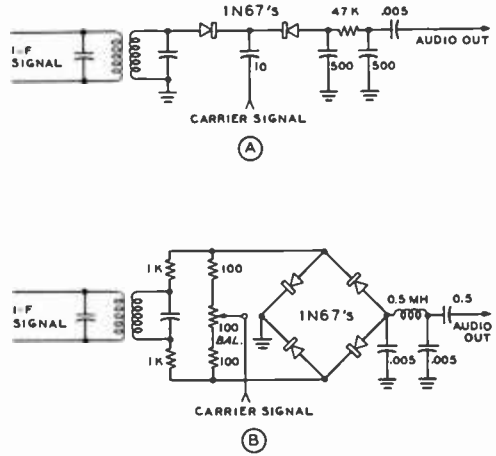

Figure 42
DIODE PRODUCT DETECTORS

A—Back-to-back diodes form simple product detector with local-oscillator signal injected at junction of diodes. Audio RC filter removes oscillator voltage from output signal.
B—Balanced Quad, commonly used for transmitting modulators, may also be used for product detector.

of the "gun." The division of plate current between the two plates is determined by the difference in voltage between two deflecting electrodes placed between the "gun" and the plates. R-f voltage is used to modulate the control grid of the electron "gun" and the electron stream within the tube may be switched between the plates by means of an audio signal applied to the deflecting electrodes. The 7360 makes an excellent balanced modulator (figure 44) or product detector having high-impedance input circuits, low distortion, and excellent carrier suppression.

A Representative SSB Receiver A typical SSB receiver made up of circuits resembling those discussed in the previous section. To achieve both high stability and good image rejection, many amateur SSB receivers are double-conversion types, such as outlined in figure 45. An accurate, stable low-frequency tunable oscillator is employed, together with a standard 455-kHz i-f channel and a crystal or mechanical SSB filter. The frequency coverage of the vfo may be as high as 500 kHz to cover all of the low-frequency amateur

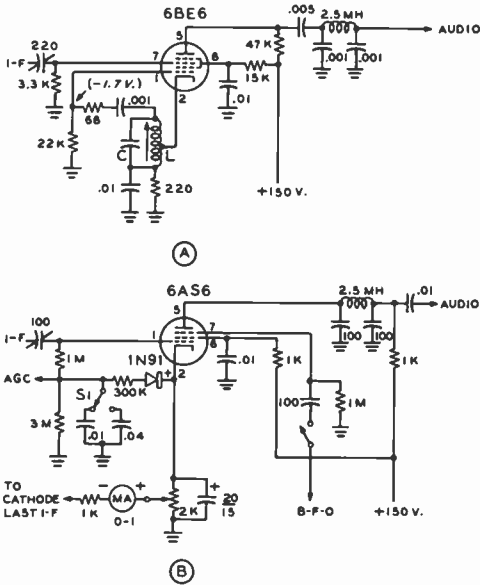

Figure 43

VACUUM-TUBE PRODUCT DETECTORS

A—The 6BE6 pentagrid converter may be used as combined product detector and local oscillator. Maximum input level is controlled by variable injection of i-f signal. Circuit LC is a common bfo transformer.

B—A 6AS6 and separate bfo make excellent product detector having a very low level of intermodulation distortion. Agc-voltage and S-meter circuits are incorporated in this schematic. Time constant of agc control voltage is adjusted by switch S₁.

bands, or it may be restricted to only 100 kHz or so, necessitating the use of a multiplicity of crystals in the first conversion oscillator to achieve complete band coverage. A tunable first i-f stage covering the required passband may be ganged with the variable-frequency oscillator and with the r-f amplifier tuning circuits. The high-frequency tuning range is chosen by the appropriate high-frequency crystal.

To permit sideband selection, the bfo may be tuned to either side of the i-f passband. Proper tuning is accomplished by ear, the setting of the bfo on the filter passband slope may be quickly accomplished by experience and by recognition of the proper voice tones.

In addition to the special circuitry covered in this chapter, SSB receivers make full use of the general receiver design information given in Chapter Ten of this Handbook.

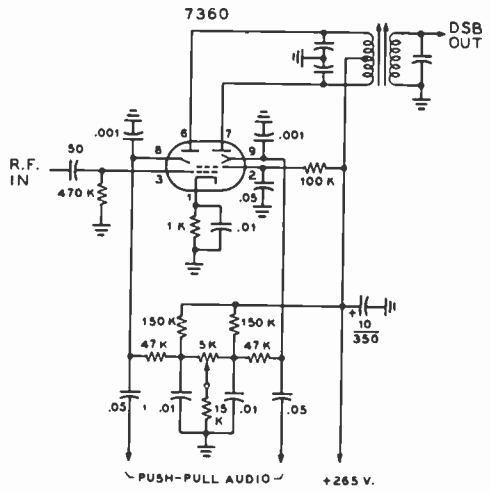

Figure 44

BALANCED MODULATOR CIRCUIT USING 7360 BEAM DEFLECTION TUBE.

16-11 The SSB Transceiver

The SSB transceiver is a unit in which the functions of transmission and reception are combined, allowing single-channel semi-duplex operation at a substantial reduction in cost and complexity along with greatly increased ease of operation. The transceiver is especially popular for mobile operation where a savings in size, weight, and power consumption are important. Dual usage of components and stages in the SSB transceiver permits a large reduction in the number of circuit elements and facilitates tuning to the common frequency desired for two-way communication.

Figure 46 shows a basic filter-type transceiver circuit. Common mixer frequencies are used in each mode and the high-frequency vfo is used to tune both transmit and receive channels to the same operating frequency. In addition, a common i-f system and sideband filter are used.

The transceiver is commonly switched from receive to transmit by a multiple-contact relay which transfers the antenna and removes blocking bias from the activated

Figure 45
DOUBLE CONVERSION
SSB RECEIVER

Typical double-conversion SSB receiver employs tunable first i-f and crystal-controlled local oscillator, with tunable oscillator and fixed-frequency i-f amplifier and sideband filter. This receiver tunes selected 500-kHz segments of the h-f spectrum. Additional conversion crystals are required for complete coverage of the 10-meter band.

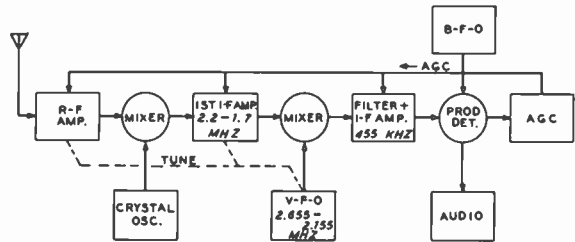

TUNING RANGE (MHZ)	CRYSTAL (MHZ)
3.5 - 4.0	5.7
7.0 - 7.5	9.0
14.0 - 14.5	18.2
21.0 - 21.5	23.2
28.5 - 29.0	30.7

Figure 46
THE SSB TRANSCEIVER

Common carrier oscillator, i-f amplifier/filter, and vfo are used in transceiver, designed to communicate on a single frequency selected by proper vfo setting. Transfer from receive to transmit is carried out by relays and by application of blocking voltage to unused tubes.

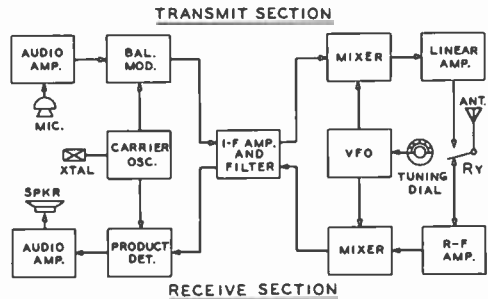

stages. Transceivers are ideal for net operation since the correct frequency may be ascertained by tuning the received signal to make the voice intelligible and pleasing. With practice, the SSB transceiver may be adjusted to a predetermined frequency with an error of 100 Hz or less by this simple procedure.

Single-Band Transceivers A recent development has been the single-band transceiver, a simplified circuit designed for operation over one narrow frequency band.

Various designs have been made available for the 50MHz band and a recent transceiver kit has been put on the market for the 160-meter band. Commercial transceiver designs are usually operated on crystal-controlled channels in the h-f and vhf spectrum using a crystal synthesizer for channel control. Elaborate synthesizers permit selection of discrete operating frequencies as closely separated as 100 Hz. Some units include a clarifier control which permits a slight frequency adjustment to place the unit exactly on the chosen operating channel.

Equipment Design

The performance of communication equipment is a function of the design, and is dependent on the execution of the design and the proper choice of components. This chapter deals with the study of equipment circuitry and the basic components that go to make up this circuitry. Modern components are far from faultless. Resistors have inductance and reactance, and inductors have resistance and distributed capacitance. None of these residual attributes show up on circuit diagrams, yet they are as much responsible for the success or failure of the equipment as are the necessary and vital bits of resistance, capacitance, and inductance. Because of these unwanted attributes, the job of translating a circuit on paper into a working piece of equipment often becomes an impossible task to those individuals who disregard such important trivia. Rarely do circuit diagrams show such pitfalls as ground loops and residual inductive coupling between stages. Parasitic resonant circuits are seldom visible from a study of the schematic. Too many times radio equipment is rushed into service before it has been entirely checked. The immediate and only too apparent results of this enthusiasm are receiver instability, transmitter instability, difficulty of neutralization, r.f. wandering all over the equipment, and a general "touchiness" of adjustment. Hand in glove with these problems go the more serious ones of receiver overload, TVI, keyclicks, and parasitics. By paying attention to detail, with a good working

knowledge of the limitations of the components, and with a basic concept of the actions of ground currents, the average amateur will be able to build equipment that will work "just like the book says."

The twin problems of TVI and parasitics are an outgrowth of the major problem of over all circuit design. If close attention is paid to the cardinal points of circuitry design, the secondary problems of TVI and parasitics will in themselves be solved.

17-1 Resistors

The resistance of a conductor is a function of the material, the form the material takes, the temperature of operation, and the frequency of the current passing through the resistance. In general, the variation in resistance due to temperature is directly proportional to the temperature change. With most wirewound resistors, the resistance increases with temperature and returns to its original value when the temperature drops to normal. So called composition or carbon resistors have less reliable temperature/resistance characteristics. They usually have a positive temperature coefficient, but the retrace curve as the resistor is cooled is often erratic, and in many cases the resistance does not return to its original value after a heat cycle. It is for this reason that care must be taken when soldering composition resistors in circuits that require close control of the

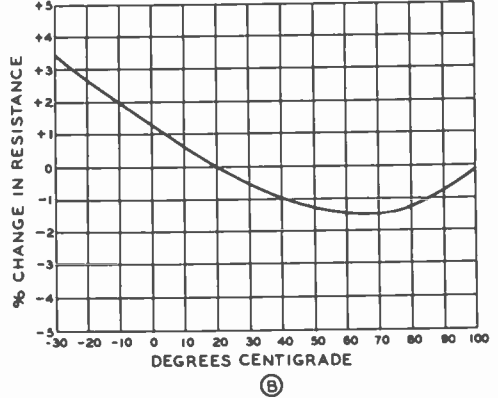
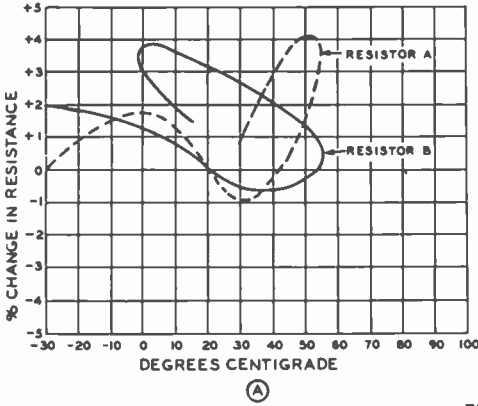

Figure 1

HEAT CYCLE OF UNCONDITIONED COMPOSITION RESISTORS

HEAT CYCLE OF CONDITIONED COMPOSITION RESISTORS

resistance value. Matched resistors used in phase-inverter service can be heated out of tolerance by the act of soldering them into the circuit. Long leads should be left on the resistors and long-nose pliers should grip the lead between the iron and the body of the resistor to act as a heat block. General temperature characteristics of typical carbon resistors are shown in figure 1. The behavior of an individual resistor will vary from these curves depending on the manufacturer, the size and wattage of the resistor, etc.

sirable amounts of inductance and distributed capacitance. These quantities are illustrated in figure 2A, the general equivalent circuit of a resistor. This circuit represents the actual impedance network of a resistor at any frequency. At a certain specified frequency the impedance of the resistor may be thought of as a series reactance (X_R) as shown in figure 2B. This reactance may be either inductive or capacitive depending on whether the residual inductance or the distributed capacitance of the resistor is the dominating factor. As a rule, skin effect tends to increase the reactance with frequency, while the capacitance between turns of a wirewound resistor, or capacitance be-

Inductance of Resistors Every resistor because of its physical size has in addition to its desired resistance, less de-

Figure 2

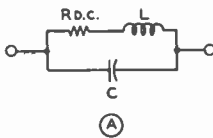

EQUIVALENT CIRCUIT OF A RESISTOR



(B)

EQUIVALENT CIRCUIT OF A RESISTOR AT A PARTICULAR FREQUENCY

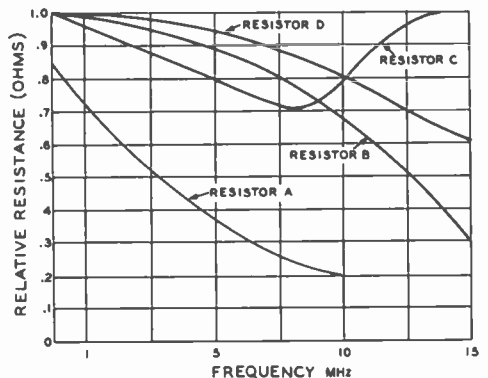

Figure 3
FREQUENCY EFFECTS ON SAMPLE COMPOSITION RESISTORS

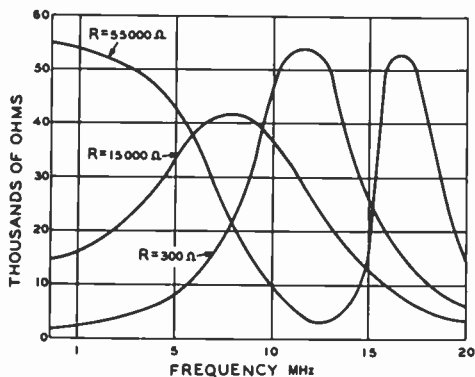

Figure 4

CURVES OF THE IMPEDANCE OF WIRE-WOUND RESISTORS AT RADIO FREQUENCIES

tween the granules of a composition resistor tends to cause the reactance and resistance to drop with frequency. The behavior of various types of composition resistors over a large frequency range is shown in figure 3. By proper component design, noninductive resistors having a minimum of residual reactance characteristics may be constructed. Even these have reactive effects that cannot be ignored at high frequencies.

Wirewound resistors act as low- Q inductors at radio frequencies. Figure 4 shows typical curves of the high-frequency characteristics of cylindrical wirewound resistors. In addition to resistance variations wirewound resistors exhibit both capacitive and inductive reactance, depending on the type of resistor and the operating frequency. In fact, such resistors perform in a fashion as low- Q r-f chokes below their parallel self-resonant frequency.

17-2 Capacitors

The inherent residual characteristics of capacitors include series resistance, series inductance and shunt resistance, as shown in figure 5. The series resistance and inductance depend to a large extent on the physical configuration of the capacitor and on the material from which it is composed. Of great interest to the amateur constructor is the series inductance of the capacitor. At a cer-

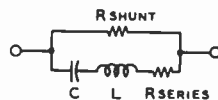

Figure 5

EQUIVALENT CIRCUIT OF A CAPACITOR

tain frequency the series inductive reactance of the capacitor and the capacitive reactance are equal and opposite, and the capacitor is in itself series resonant at this frequency. As the operating frequency of the circuit in which the capacitor is used is increased above the series-resonant frequency, the effectiveness of the capacitor as a bypassing element deteriorates until the unit is useless.

Bypass Capacitors The usual forms of bypass capacitors have dielectrics of paper, mica, or ceramic. For audio work, and low-frequency r-f work up to perhaps 2 MHz or so, the paper capacitors are satisfactory as their relatively high internal inductance has little effect on the proper operation of the circuit. The actual amount of internal inductance will vary widely with the manufacturing process, and some types of paper capacitors have satisfactory characteristics up to a frequency of 5 MHz or so.

When considering the design of transmitting equipment, it must be remembered that while the transmitter is operating at some relatively low frequency (for example, 7 MHz), there will be harmonic currents flowing through the various bypass capacitors of the order of 10 to 20 times the operating frequency. A capacitor that behaves properly at 7 MHz however, may offer considerable impedance to the flow of these harmonic currents. For minimum harmonic generation and radiation, it is obviously of greatest importance to employ bypass capacitors having the lowest possible internal inductance.

Mica-dielectric capacitors have much less internal inductance than do most paper capacitors. Figure 6 lists self-resonant frequencies of various mica capacitors having various lead lengths. It can be seen from inspection of this table that most mica capacitors become self-resonant in the 12- to 50-MHz region. The inductive reactance

CAPACITOR	LEAD LENGTHS	RESONANT FREQ.
.02 μ fd MICA	NONE	44.5 MHz
.002 μ fd MICA	NONE	23.5 MHz
.01 μ fd MICA	$\frac{1}{8}$ "	10 MHz
.0009 μ fd MICA	$\frac{1}{8}$ "	55 MHz
.002 μ fd CERAMIC	$\frac{3}{8}$ "	24 MHz
.001 μ fd CERAMIC	$\frac{1}{8}$ "	55 MHz
500 pf BUTTON	NONE	220 MHz
.0005 μ fd CERAMIC	$\frac{1}{8}$ "	90 MHz
.01 μ fd CERAMIC	$\frac{1}{2}$ "	14.5 MHz

Figure 6

SELF-RESONANT FREQUENCIES OF VARIOUS CAPACITORS WITH RANDOM LEAD LENGTH

they would offer to harmonic currents of 100 MHz, or so, would be of considerable magnitude. In certain instances it is possible to deliberately series-resonate a mica capacitor to a certain frequency somewhat below its normal self-resonant frequency by trimming the leads to a critical length. This is sometimes done for maximum bypassing effect in the region of 40 to 60 MHz.

The *button-mica* capacitors shown in figure 7 are especially designed to have extremely low internal inductance. Certain types of button-mica capacitors of small physical size have a self-resonant frequency in the region of 600 MHz.

Ceramic-dielectric capacitors in general have the lowest amount of series inductance per unit of capacitance of these three universally used types of bypass capacitors. Typical resonant frequencies of various ceramic units are listed in figure 6. Ceramic capacitors are available in various voltage and capacitance ratings and different physical configurations. Standoff types such as shown in figure 7 are useful for bypassing socket and transformer terminals. Two of these capacitors may be mounted in close proximity on a chassis and connected together by an r-f choke to form a highly effective r-f filter. The inexpensive *disc* type of ceramic capacitor is recommended for general bypassing in r-f circuitry, as it is effective as a bypass unit to well over 100 MHz.

The large TV *doorknob* capacitors are useful as by-pass units for high voltage lines. These capacitors have a value of 500 pf, and are available in voltage ratings up to 40,000 volts. The dielectric of these capacitors is usually titanium dioxide. This material ex-

hibits piezoelectric effects, and capacitors employing it for a dielectric will tend to "talk-back" when a-c voltages are applied across them. When these capacitors are used as plate bypass units in a modulated transmitter they will cause acoustical noise. Otherwise they are excellent for general r-f work.

A recent addition to the varied line of capacitors is the *coaxial*, or *Hypass*, type of capacitor. These capacitors exhibit superior bypassing qualities at frequencies up to 200 MHz and the bulkhead type are especially effective when used to filter leads passing through partition walls between two stages.

Variable Air Capacitors Even though air is the perfect dielectric, air capacitors exhibit losses because of the inherent resistance of the metallic parts that make up the capacitor. In addition, the leakage loss across the insulating supports may become of some consequence at high frequencies. Of greater concern is the inductance of the capacitor at high frequencies. Since the capacitor must be of finite size, it will have tie rods, metallic braces, and end plates; all of which contribute to the inductance of the unit. The actual amount of the inductance will depend on the physical size of the capacitor

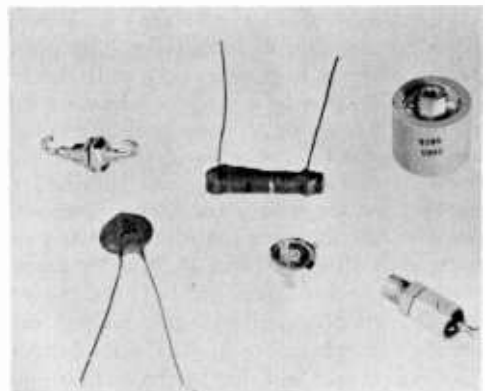

Figure 7

TYPES OF CERAMIC AND MICA CAPACITORS SUITABLE FOR HIGH-FREQUENCY BYPASSING

The Centralab 8585 (1000 pf) is recommended for screen and plate circuits of tetrode tubes.

and the method used to make contact to the stator and rotor plates. This inductance may be cut to a minimum value by using as small a capacitor as is practical, by using insulated tie rods to prevent the formation of closed inductive loops in the frame of the unit, and by making connections to the centers of the plate assemblies rather than to the ends as is commonly done. A large transmitting capacitor may have an inherent inductance as large as 0.1 microhenry, making the capacitor susceptible to parasitic resonances in the 50- to 150-MHz range of frequencies.

The question of optimum C/L ratio and capacitor plate spacing is covered in Chapter Eleven. For all-band operation of a high-power stage, it is recommended that a capacitor just large enough for 40-meter operation be chosen. (This will have sufficient capacitance for operation on all higher-frequency bands.) Then use fixed padding capacitors for operation on 80 meters. Such padding capacitors are available in air, ceramic, and vacuum types.

Specially designed variable capacitors are recommended for uhf work; ordinary capacitors often have "loops" in the metal frame which may resonate near the operating frequency.

17-3 Wire and Inductors

Any length of wire, no matter how short, has a certain value of inductance. This property is of great help in making coils and inductors, but may be of great hindrance when it is not taken into account in circuit design and construction. Connecting circuit elements (themselves having residual inductance) together with a conductor possessing additional inductance can often lead to puzzling difficulties. A piece of No. 10 copper wire ten inches long (a not uncommon length for a plate lead in a transmitter) can have a self-inductance of 0.15 microhenrys. This inductance and that of the plate tuning capacitor together with the plate-to-ground capacity of the vacuum tube can form a resonant circuit which may lead to parasitic oscillations in the vhf regions. To keep the self-inductance at a minimum, all r-f carrying leads should be as short as possible and should be made out of as heavy material as possible.

At the higher frequencies, solid enameled copper wire is most efficient for r-f leads. Tinned or stranded wire will show greater losses at these frequencies. Tank-coil and tank-capacitor leads should be of heavier wire than other r-f leads.

The best type of flexible lead from the envelope of a tube to a terminal is thin copper strip, cut from thin sheet copper. Heavy, rigid leads to these terminals may crack the envelope glass when a tube heats or cools.

Wires carrying only audio frequencies or direct current should be chosen with the voltage and current in mind. Some of the low-filament-voltage transmitting tubes draw heavy current, and heavy wire must be used to avoid voltage drop. The voltage is low, and hence not much insulation is required. Filament and heater leads are usually twisted together. An initial check should be made on the filament voltage of all tubes of 25 watts or more plate dissipation rating. This voltage should be measured right at the tube sockets. If it is low, the filament-transformer voltage should be raised. If this is impossible, heavier or parallel wires should be used for filament leads, cutting down their length if possible.

Coaxial cable may be used for high-voltage leads when it is desirable to shield them from r-f fields. RG-8/U cable may be used at d-c potentials up to 8000 volts, and the lighter RG-58/U may be used to potentials of 3000 volts. Spark plug-type high-tension wire may be used for unshielded leads, and will withstand 10,000 volts.

If this cable is used, the high-voltage leads may be cabled with filament and other low-voltage leads. For high-voltage leads in low-power exciters, where the plate voltage is not over 450 volts, ordinary radio hookup wire of good quality will serve the purpose.

No r-f leads should be cabled; in fact it is better to use enameled or bare copper wire for r-f leads and rely on spacing for insulation. All r-f joints should be soldered, and the joint should be a good mechanical junction before solder is applied.

The efficiency and Q of air coils commonly used in amateur equipment is a factor of the shape of the coil, the proximity of the coil to other objects (including the coil form), and the material from which the coil is made. Dielectric losses in so-called "air-

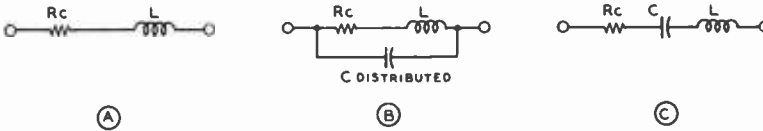

Figure 8

ELECTRICAL EQUIVALENT OF R-F CHOKE AT VARIOUS FREQUENCIES

wound" coils are low and the Q of such coils runs in the neighborhood of 300 to 500 at medium frequencies. Unfortunately, most of the transmitting-type plug-in coils on the market designed for link coupling have far too small a pickup link for proper operation at 3.5 and 7 MHz. The coefficient of coupling of these coils is about 0.5, and additional means must be employed to provide satisfactory coupling at these low frequencies. Additional inductance in series with the pickup link, the whole being resonated to the operating frequency, will often permit satisfactory coupling.

Coil Placement For best Q a coil should be in the form of a solenoid with length from one to two times the diameter. For minimum interstage coupling, coils should be made as small physically as is practicable. The coils should then be placed so that adjoining coils are oriented for minimum mutual coupling. To determine if this condition exists, apply the following test: the axis of one of the two coils must lie

in the plane formed by the center turn of the other coil. If this condition is not met, there will be appreciable coupling unless the unshielded coils are very small in diameter or are spaced a considerable distance from each other.

Insulation On frequencies above 7 MHz, ceramic, polystyrene, or *Mycalox* insulation is to be recommended. Cold flow must be considered when using polystyrene (*Amphenol 912*, etc.). Bakelite has low losses on the lower frequencies but should never be used in the field of high-frequency tank circuits.

Lucite (or *Plexiglas*), which is available in rods, sheets, or tubing, is satisfactory for use at all radio frequencies where the r-f voltages are not especially high. It is very easy to work with ordinary tools and is not expensive. The loss factor depends to a considerable extent on the amount and kind of plasticizer used.

The most important thing to keep in mind regarding insulation is that the best insulation is air. If it is necessary to reinforce air-wound coils to keep turns from vibrating or touching, use strips of *Lucite* or polystyrene cemented in place with *Amphenol 912* coil dope. This will result in lower losses than the commonly used celluloid ribs and *Duco* cement.

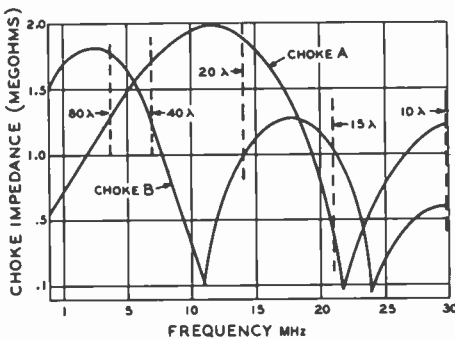

Figure 9

FREQUENCY-IMPEDANCE CHARACTERISTICS FOR TYPICAL PIE-WOUND R-F CHOKES

Radio-Frequency Chokes R-f chokes may be considered to be special inductances designed to have a high value of impedance over a large range of frequencies. A practical r-f choke has inductance, distributed capacitance, and resistance. At low frequencies, the distributed capacitance has little effect and the electrical equivalent circuit of the r-f choke is as shown in figure 8A. As the operating frequency of the choke is raised the effect of the distributed capacitance becomes more

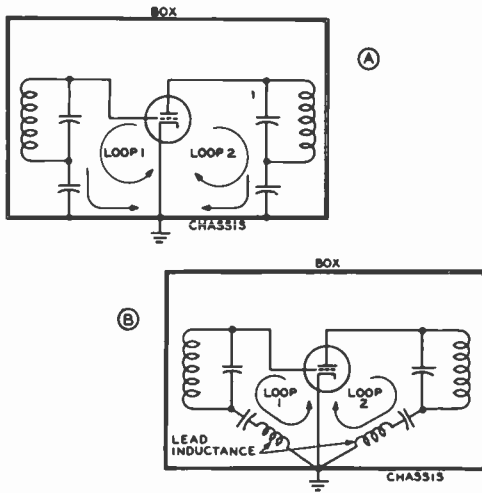

Figure 10

GROUND LOOPS IN AMPLIFIER STAGES

- A. Using chassis return
B. Common ground point

evident until at some particular frequency the distributed capacitance resonates with the inductance of the choke and a parallel-resonant circuit is formed. This point is shown in figure 8B. As the frequency of operating is further increased the over-all reactance of the choke becomes capacitive, and finally a point of series resonance is reached (figure 8C). This cycle repeats itself as the operating frequency is raised above the series-resonant point, the impedance of the choke rapidly becoming lower on each successive cycle. A chart of this action is shown in figure 9. It can be seen that as the r-f choke approaches and leaves a condition of series resonance, the performance of the choke is seriously impaired. The condition of series resonance may easily be found by shorting the terminals of the r-f choke in question with a piece of wire and exploring the windings of the choke with a grid-dip oscillator. Most commercial transmitting-type chokes have series resonances in the vicinity of 11 or 24 MHz.

17-4 Grounds

At frequencies of 30 MHz and below, a chassis may be considered as a fixed ground reference, since its dimensions are only a fraction of a wavelength. As the frequency

is increased above 30 MHz, the chassis must be considered as a conducting sheet on which there are points of maximum current and potential. However, for the lower amateur frequencies, an object may be assumed to be at ground potential when it is affixed to the chassis.

In transmitter stages, two important current loops exist. One loop consists of the grid circuit and chassis return, and the other loop consists of the plate circuit and chassis return. These two loops are shown in figure 10A. It can be seen that the chassis forms a return for both the grid and plate circuits, and that *ground currents* flow in the chassis towards the cathode circuit of the stage. For some years the theory has been to separate these ground currents from the chassis by returning all ground leads to one point, usually the cathode of the tube for the stage in question. This is well and good if the ground leads are of minute length and do not introduce cross couplings between the leads. Such a technique is illustrated in figure 10B, wherein all stage components are grounded to the cathode pin of the stage socket. However, in transmitter construction the physical size of the components prevent such close grouping. It is necessary to spread the components of such a stage over a fairly large area. In this case it is best to ground items directly to the chassis at the nearest possible point, with short, direct grounding leads. The ground currents will flow from these points through the low inductance chassis to the cathode return of the stage. Components grounded on the top of the chassis have their ground currents flow through holes to the cathode circuit which is usually located on the bottom of the chassis, since such currents travel on the surface of the chassis. The usual "top to bottom" ground path is through the hole cut in the chassis for the tube socket. When the gain per stage is relatively low, or there are only a small number of stages on a chassis this universal grounding system is ideal. It is only in high gain stages (i-f strips) where the "gain per inch" is very high that circulating ground currents will cause operational instability.

Intercoupling of Ground Currents It is important to prevent intercoupling of various different ground currents when

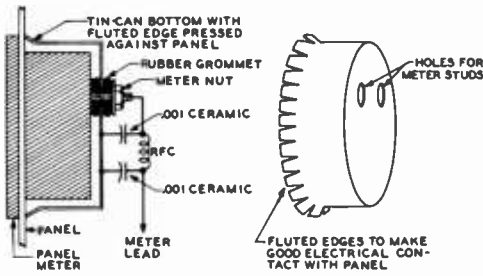

Figure 11A

SIMPLE METER SHIELD

the chassis is used as a common ground return. To keep this intercoupling at a minimum, the stage should be completely shielded. This will prevent external fields from generating spurious ground currents, and prevent the ground currents of the stage from upsetting the action of nearby stages. Since the ground currents travel on the surface of the metal, the stage should be enclosed in an electrically tight box. When this is done, all ground currents generated inside the box will remain in the box. The only possible means of escape for fundamental and harmonic currents are imperfections in this electrically tight box. Whenever we bring a wire lead into the box, make a ventilation hole, or bring a control shaft through the box we create an imperfection. It is important that the effect of these imperfections be reduced to a minimum.

17-5 Holes, Leads, and Shafts

Large size holes for ventilation may be put in an electrically tight box provided they are properly screened. Perforated metal stock having many small, closely spaced holes is the best screening material. Copper wire screen may be used provided the screen wires are bonded together every few inches. As the wire corrodes, an insulating film prevents contact between the individual wires, and the attenuation of the screening suffers. The screening material should be carefully soldered to the box, or bolted with a spacing of not less than two inches between bolts. Mating surfaces of the box and the screening should be clean.

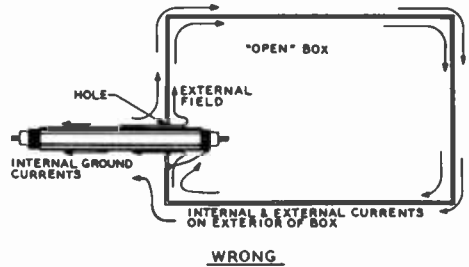
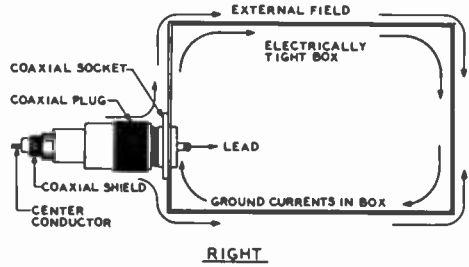

Figure 11B

Use of coaxial connectors on electrically tight box prevents escape of ground currents from interior of box. At the same time external fields are not conducted into the interior of the box.

A screened ventilation opening should be roughly three times the size of an equivalent unshielded opening, since the screening represents about a 70 percent coverage of the area. Careful attention must be paid to equipment heating when an electrically tight box is used.

Commercially available panels having half-inch ventilating holes may be used as part of the box. These holes have much less attenuation than does screening, but will perform in a satisfactory manner in all but the areas of weakest TV reception. If it is desired to reduce leakage from these panels to a minimum, the back of the grill must be covered with screening tightly bonded to the panel.

Doors may be placed in electrically tight boxes provided there is no r-f leakage around the seams of the door. Electronic weatherstripping or metal "finger stock" may be used to seal these doors. A long, narrow slot in a closed box has the tendency to act as a slot antenna and harmonic energy may pass more readily through such an opening than it would through a much larger circular hole.

Variable-capacitor or switch shafts may act as antennas, picking up currents inside the box and re-radiating them outside of the box. It is necessary either to ground the shaft securely as it leaves the box, or else to make the shaft of some insulating material.

A two- or three-inch panel meter causes a large leakage hole if it is mounted in the wall of an electrically tight box. To minimize leakage, the meter leads should be bypassed and shielded. The meter should be encased in a metal shield that makes contact to the box entirely around the meter. The connecting studs of the meter may project through the back of the metal shield. Such a shield may be made out of the end of a tin or aluminum can of correct diameter, cut to fit the depth of the meter. This complete shield assembly is shown in figure 11A.

Careful attention should be paid to leads entering and leaving the electrically tight box. Harmonic currents generated inside the box can easily flow out of the box on power or control leads, or even on the outer shields of coaxially shielded wires. Figure 11B illustrates the correct method of bringing shielded cables into a box where it is desired to preserve the continuity of the shielding.

Unshielded leads entering the box must be carefully filtered to prevent fundamental and harmonic energy from escaping down the lead. Combinations of r-f chokes and low-inductance bypass capacitors should be used in power leads. If the current in the lead is high, the chokes must be wound of large-gauge wire. Composition resistors may be substituted for the r-f chokes in high-impedance circuits. Bulkhead or feedthrough type capacitors are preferable when passing a lead through a shield partition. A summary of lead leakage with various filter arrangements is shown in figure 12.

Internal Leads Leads that connect two points within an electrically tight box may pick up fundamental and harmonic currents if they are located in a strong field of flux. Any lead forming a closed loop with itself will pick up such currents, as shown in figure 13. This effect is enhanced if the lead happens to be self-resonant at the frequency of the exciting energy. The solution for all of this is to bypass all internal power leads and control leads at each end, and to shield these leads their entire length. All

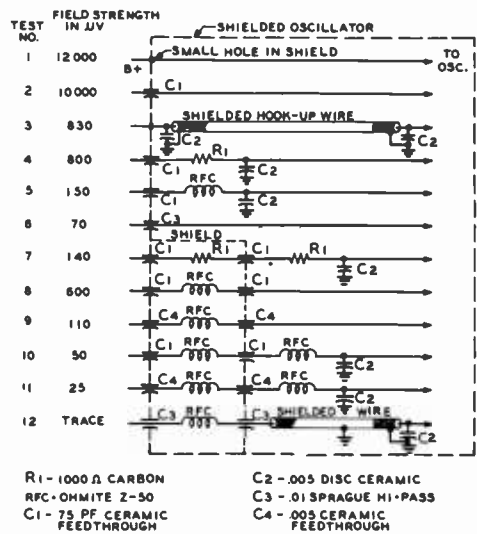

Figure 12

LEAD LEAKAGE WITH VARIOUS LEAD-FILTERING SYSTEMS

filament, bias, and meter leads should be so treated. This will make the job of filtering the leads as they leave the box much easier, since normally "cool" leads within the box will not have picked up spurious currents from nearby "hot" leads.

17-6 Parasitic Resonances

Filament leads within vacuum tubes may resonate with the filament bypass capacitors at some particular frequency and cause instability in an amplifier stage. Large tubes of the 4-1000A and 3-1000Z type are prone to this spurious effect. In particular, an amplifier using .001- μ fd filament bypass capacitors had a filament resonant loop that fell in the 7-MHz amateur band. When the amplifier was operated near this frequency, marked instability was noted, and the filaments of the tubes increased in brilliance when plate voltage was applied to the amplifier, indicating the presence of r.f. in the filament circuit. Changing the filament bypass capacitors to .01 μ fd lowered the filament resonance frequency to 2.2 MHz and cured this effect. A 1-kV mica capacitor of .01 μ fd used as a filament bypass capacitor on each filament leg seems to be satisfactory

Figure 13

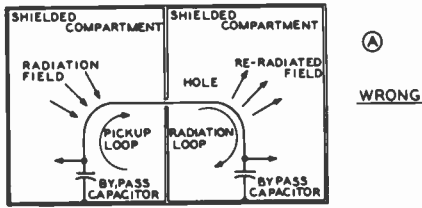

ILLUSTRATION OF HOW A SUPPOSEDLY GROUNDLED POWER LEAD CAN COUPLE ENERGY FROM ONE COMPARTMENT TO ANOTHER

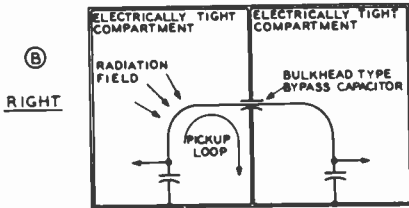

ILLUSTRATION OF LEAD ISOLATION BY PROPER USE OF BULKHEAD BYPASS CAPACITOR

from both a resonant and a TVI point of view. Filament bypass capacitors smaller in value than .01 μ fd should be used with caution.

Various parasitic resonances are also found in plate and grid tank circuits. Push-pull tank circuits are prone to double resonances, as shown in figure 14. The parasitic resonance circuit is usually several MHz higher than the actual resonant frequency of the full tank circuit. The cure for such a double resonance is the inclusion of an r-f choke in the center-tap lead to the split coil.

Chassis Material From a point of view of electrical properties, aluminum is a poor chassis material. It is difficult to make a soldered joint to it, and all grounds must rely on a pressure joint. These pressure joints are prone to give trouble at a later date because of high resistivity caused by the formation of oxides from electrolytic action in the joint. However, the ease of working and forming the aluminum material far outweighs the electrical shortcomings,

and aluminum chassis and shielding may be used with good results provided care is taken in making all grounding connections. Cadmium and zinc plated chassis are preferable from a corrosion standpoint, but are much more difficult to handle in the home workshop.

17-7 Parasitic Oscillation in R-F Amplifiers

Parasitics (as distinguished from *self-oscillation* on the normal tuned frequency of the amplifier) are undesirable oscillations either of very-high or very-low frequencies which may occur in radio-frequency amplifiers.

They may cause spurious signals (which are often rough in tone) other than normal harmonics, hash on each side of a modulated carrier, key clicks, voltage breakdown or flash-over, instability or inefficiency, and shortened life or failure of the tubes. They may be damped and stop by themselves after keying or modulation peaks, or they may be undamped and build up during ordinary unmodulated transmission, continuing if the excitation is removed. They may result from series- or parallel-resonant circuits of all types. Due to neutralizing lead length and the nature of most parasitic circuits, the amplifier usually is not neutralized for the parasitic frequency.

Sometimes the fact that the plate supply is keyed will obscure parasitic oscillations in a final amplifier stage that might be very

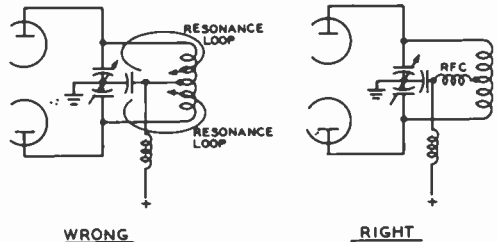

Figure 14
DOUBLE RESONANCE EFFECTS IN PUSH-PULL TANK CIRCUIT MAY BE ELIMINATED BY THE INSERTION OF AN R-F CHOKE IN THE COIL CENTER TAP LEAD

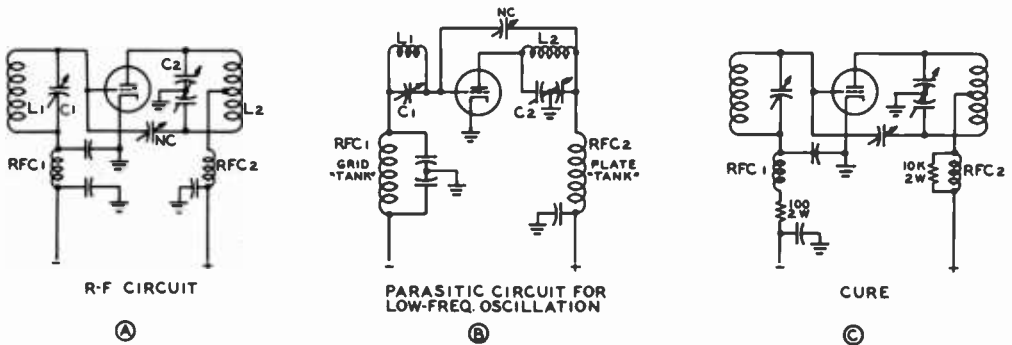

Figure 15

LOW-FREQUENCY PARASITIC SUPPRESSION

A—Low-frequency parasitic circuit is formed by grid and plate r-f chokes and associated bypass capacitors, as shown at B. Fundamental-frequency tank circuits have little effect on parasitic frequency. **C**—Parasitic circuits are "de-Q'ed" by addition of either series or parallel resistance until circuit will not sustain oscillation.

severe if the plate voltage were left on and the excitation were keyed.

In some cases, an all-wave receiver will prove helpful in locating vhf spurious oscillations, but it may be necessary to check from several hundred MHz downward in frequency to the operating range. A normal harmonic is weaker than the fundamental but of good tone; a strong harmonic or a rough note at any frequency generally indicates a parasitic.

In general, the cure for parasitic oscillation is twofold: The oscillatory circuit is damped until sustained oscillation is impossible, or it is detuned until oscillation ceases. An examination of the various types of parasitic oscillations and of the parasitic oscillatory circuits will prove handy in applying the correct cure.

Low-Frequency Parasitic Oscillations One type of unwanted oscillation often occurs in shunt-fed circuits in which the grid and plate chokes resonate, coupled through the tube's interelectrode capacitance. This also can happen with series feed. This oscillation is generally at a much lower frequency than the operating frequency and will cause additional carriers to appear, spaced from perhaps twenty to a few hundred kHz on either side of the main wave. Such a circuit is illustrated in figure 15. In this case, RFC₁ and RFC₂ form the

grid and plate inductances of the parasitic oscillator. The neutralizing capacitor, no longer providing out-of-phase feedback to the grid circuit, actually enhances the low-frequency oscillation. Because of the low Q of the r-f chokes, they will usually run warm when this type of parasitic oscillation is present and may actually char and burn up. A neon bulb held near the oscillatory circuit will glow a bright yellow, the color appearing near the glass of the neon bulb and not between the electrodes.

One cure for this type of oscillation is to change the type of choke in either the plate or the grid circuit. This is a marginal cure, because the amplifier may again break into the same type of oscillation when the plate voltage is raised slightly. The best cure is to remove the grid r-f choke entirely and replace it with a wirewound resistor of sufficient wattage to carry the amplifier grid current. If the inclusion of such a resistor upsets the operating bias of the stage, an r-f choke may be used, with a 100-ohm 2-watt carbon resistor in series with the choke to lower the operating Q of the choke. If this expedient does not eliminate the condition, and the stage under investigation uses a beam-tetrode tube, negative resistance can exist in the screen circuit of such tubes. Try larger and smaller screen bypass capacitors to determine whether or not they have any effect. If the condition is coming from the screen circuit an audio choke with a resistor across it in

series with the screen-feed lead will often eliminate the trouble.

Low-frequency parasitic oscillations can often take place in the audio system of an a-m transmitter, and their presence will not be known until the transmitter is checked on a receiver. It is easy to determine whether or not the oscillations are coming from the modulator simply by switching off the modulator tubes. If the oscillations are coming from the modulator, the stage in which they are being generated can be determined by removing tubes successively, starting with the first speech amplification stage, until the oscillation stops. When the stage has been found, remedial steps can be taken on that stage.

If the stage causing the oscillation is a low-level speech stage it is possible that the trouble is coming from r-f or power-supply feedback, or it may be coming about as a result of inductive coupling between two transformers. If the oscillation is taking place in a high-level audio stage, it is possible that inductive or capacitive coupling is taking place back to one of the low-level speech stages.

17-8 Elimination of VHF Parasitic Oscillations

Vhf parasitic oscillations are often difficult to locate and difficult to eliminate since their frequency often is only moderately above the desired frequency of operation. But it may be said that vhf parasitics always may be eliminated if the operating frequency is appreciably below the upper frequency limit for the tubes used in the stage. However, the elimination of a persistent parasitic oscillation on a frequency only moderately higher than the desired operating frequency will involve a sacrifice in either the power output or the power sensitivity of the stage, or in both.

Beam-tetrode stages, particularly those using 6146 or TV-style sweep tubes, will almost invariably have one or more vhf parasitic oscillations unless adequate precautions have been taken in advance. Many of the units described in the constructional section of this edition had parasitic oscillations

when first constructed. But these oscillations were eliminated in each case; hence, the expedients used in these equipments should be studied. Vhf parasitics may be readily identified, as they cause a neon lamp to have a purple glow close to the electrodes when it is excited by the parasitic energy.

Parasitic Oscillations with Triodes In the case of triodes, vhf parasitic oscillations

often come about as a result of inductance in the neutralizing leads. This is particularly true in the case of push-pull amplifiers. The cure for this effect will usually be found in reducing the length of the neutralizing leads and increasing their diameter. Both the reduction in length and increase in diameter will reduce the inductance of the leads and tend to raise the parasitic oscillation frequency until it is out of the range at which the tubes will oscillate. The use of straight-forward circuit design with short leads will assist in forestalling this trouble at the outset.

Vhf parasitic oscillations may take place as a result of inadequate bypassing or long bypass leads in the filament, grid-return, and plate-return circuits. Such oscillations also can take place when long leads exist between the grids and the grid tuning capacitor or between the plates and the plate tuning capacitor. Sometimes parasitic oscillations can be eliminated by using iron or nichrome wire for the neutralizing leads. But in any event it will always be found best to make the neutralizing leads as short and of as heavy conductor as is practicable.

To increase losses at the parasitic frequency, the parasitic coils may be wound on 100-ohm 2-watt resistors. These "lossy" suppressors should be placed in the grid leads of the tubes close to the grid connection, as shown in figure 16.

Parasitics with Beam Tetrodes Where beam-tetrode tubes are used in the stage which has been found to be generating the parasitic oscillation, all the foregoing suggestions apply in general. However, there are certain additional considerations involved in elimination of parasitics from beam-tetrode amplifier stages. These considerations

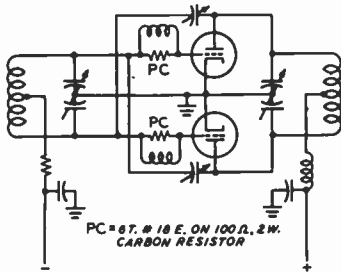

Figure 16

GRID PARASITIC SUPPRESSORS IN PUSH-PULL TRIODE STAGE

involve the facts that a beam-tetrode amplifier stage has greater power sensitivity than an equivalent triode amplifier, such a stage has a certain amount of screen-lead inductance which may give rise to trouble, and such stages have a small amount of feedback capacitance.

Beam-tetrode stages often will require the inclusion of a neutralizing circuit to eliminate oscillation on the operating frequency. However, oscillation on the operating frequency is not normally called a parasitic oscillation, and different measures are required to eliminate the condition.

When a parasitic oscillation is found on a very high frequency, the interconnecting leads of the tube, the tuning capacitors and the bypass capacitors are involved. This type of oscillation generally does not occur

when the amplifier is designed for vhf operation where the r-f circuits external to the tube have small tuning capacitors and inductors. Without tuning capacitors, the highest frequency of oscillation is then the fundamental frequency and no higher frequencies of resonance exist for the parasitic oscillation.

The vhf oscillation commonly occurs in h-f amplifiers, using the capacitors and associated grid and plate leads for the inductances of the tuned circuit. The frequency of unwanted oscillation is generally well above the self-neutralizing frequency of the tube. If the frequency of the parasitic can be lowered to or below the self-neutralizing frequency, complete suppression of the parasitic will result. It is also possible to suppress the oscillation by loading the circuit so that the circuit is "lossy" at the parasitic frequency. This may be done by the use of a parasitic choke in the plate and/or grid lead of the stage in question. A parallel coil and resistor combination operates on the principle that the resistor loads the vhf circuit but is shunted by the coil for the lower fundamental frequency. The parasitic choke (figure 17) is usually made up of a noninductive resistor of about 25 to 100 ohms, shunted by three or four turns of wire, approximately one-half inch in diameter and frequently wound over the body of the resistor.

In the process of adjusting the resistor-coil combination, it may be found that the

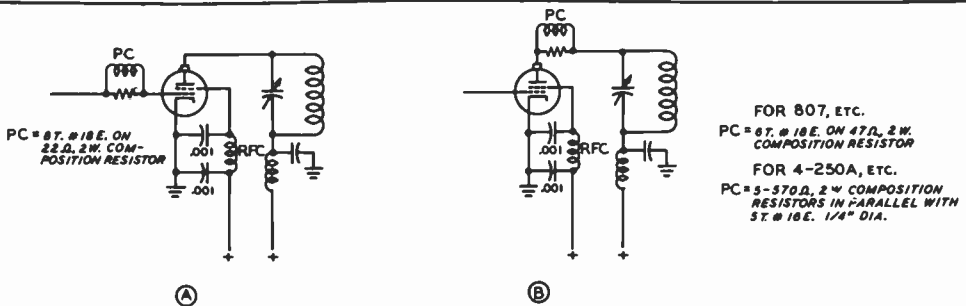

Figure 17

PLATE AND GRID PARASITIC SUPPRESSION IN TETRODE TUBES

R-C-type parasitic chokes are placed in grid (A) or plate (B) lead of tetrode and pentode tubes as shown above. Too few turns on the parasitic choke will not completely suppress the parasitic, whereas too many turns will permit the shunt resistor to absorb too much fundamental power. Five turns for the shunt coil will work well to 14 MHz. For 21 and 28 MHz, the shunt coil should be reduced to three turns.

resistor runs too hot. The heat is usually caused by the dissipation of fundamental power in the resistor, which is an indication of too many turns in the suppressor coil. Just enough turns should be used to suppress the parasitic oscillation, and no more. Once the circuit is properly loaded and the parasitic suppressed, no parasitic power will be present and no power other than primary power will be lost in the resistor of the suppressor.

For medium power levels, a plate suppressor may be made of a 22-ohm, 2-watt Ohmite or Allen-Bradley composition resistor wound with 4 turns of No. 18 enameled wire. For kilowatt stages operating up to 30 MHz, a satisfactory plate suppressor may be made of three 220-ohm, 2-watt composition resistors in parallel, shunted by 3 or 4 turns of No. 14 enameled wire, 1/2-inch diameter and 1/2-inch long.

The parasitic suppressor for the plate circuit of a small tube such as the 5763, 2E26, 6146, 6LQ6, or similar type normally may consist of a 47-ohm composition resistor of 2-watt size with 4 turns of No. 18 enameled wire wound around the resistor. However, for operation above 30 MHz, special tailoring of the value of the resistor and the size of the coil wound around it will be required in order to attain satisfactory parasitic suppression without excessive power loss in the parasitic suppressor.

Tetrode Screening Isolation between the grid and plate circuits of a tetrode tube is not perfect. For maximum stability, it is recommended that the tetrode

stage be neutralized. Neutralization is *absolutely necessary* unless the grid and plate circuits of the tetrode stage are each completely isolated from each other in electrically tight boxes. Even when this is done, the stage will show signs of regeneration when the plate and grid tank circuits are tuned to the same frequency. Neutralization will eliminate this regeneration. Any of the neutralization circuits described in the chapter *Generation of R-F Energy* may be used.

17-9 Checking for Parasitic Oscillations

It is an unusual transmitter which harbors no parasitic oscillations when first constructed and tested. Therefore it is always wise to follow a definite procedure in checking a new transmitter for parasitic oscillations.

Parasitic oscillations of all types are most easily found when the stage in question is running by itself, with full plate (and screen) voltage, sufficient protective bias to limit the plate current to a safe value, and no excitation. One stage should be tested at a time, and the complete transmitter should never be put on the air until all stages have been thoroughly checked for parasitics.

To protect tetrode tubes during tests for parasitics, the screen voltage should be applied through a series resistor which will limit the screen current to a safe value in case the plate voltage of the tetrode is suddenly removed when the screen supply is on. The correct procedure for parasitic testing is as follows (figure 18):

1. The stage should be coupled to a dummy load, and tuned up in correct operating shape. Sufficient protective bias should be applied to the tube at all times. For protection of the stage under test, a lamp bulb should be added in series with one leg of the primary circuit of the high-voltage power supply. As the plate-supply load increases during a period of parasitic oscillation, the voltage drop across the lamp increases, and the effective plate voltage drops. Bulbs of various sizes may be tried to adjust the voltage under testing conditions to the correct amount. If a *Variac* or *Powerstat* is at hand, it may be used in place of

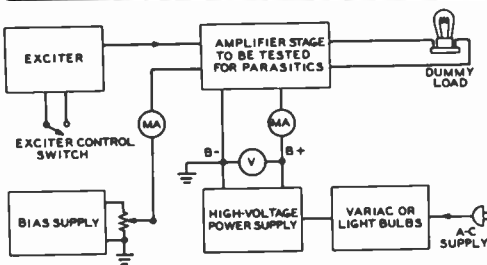

Figure 18

SUGGESTED TEST SETUP FOR PARASITIC TESTS

the bulbs for smoother voltage control. Don't test for parasitics unless some type of voltage control is used on the high-voltage supply! When a stage breaks into parasitic oscillations, the plate current increases violently and some protection to the tube under test *must* be used.

2. The r-f excitation to the tube should now be removed. When this is done, the grid, screen, and plate currents of the tube should drop to zero. Grid and plate tuning capacitors should be tuned to minimum capacity. No change in resting grid, screen, or plate current should be observed. If a parasitic is present, grid current will flow, and there will be an abrupt increase in plate current. The size of the lamp bulb in series with the high-voltage supply may be varied until the stage can oscillate continuously, without exceeding the rated plate or screen dissipation of the tube.

3. The frequency of the parasitic may now be determined by means of an absorption wavemeter, or a neon bulb. Low-frequency oscillations will cause a neon bulb to glow yellow. High-frequency oscillations will cause the bulb to have a soft, violet glow.

4. When the stage can pass the above test with no signs of parasitics, the bias supply of the tube in question should be decreased until the tube is dissipating its full plate rating when full plate voltage is applied, with no r-f excitation. Excitation may now be applied and the stage loaded to full input into a dummy load. The signal should now be monitored in a nearby receiver which has the antenna terminals grounded or otherwise

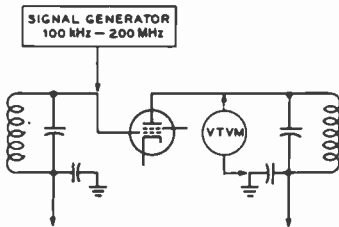

Figure 19

PARASITIC GAIN MEASUREMENT

Grid-dip oscillator and vacuum tube voltmeter may be used to measure parasitic stage gain over 100 kHz-200 MHz region.

shorted out. A series of rapid dots should be sent, and the frequency spectrum for several MHz each side of the carrier frequency carefully searched. If any vestige of parasitic is left, it will show up as an occasional "pop" on a keyed dot. This "pop" may be enhanced by a slight detuning of the grid or plate.

5. If such a parasitic shows up, it means that the stage is still not stable, and further measures must be applied to the circuit. Parasitic suppressors may be needed in both screen and grid leads of a tetrode, or perhaps in both grid and neutralizing leads of a triode stage. As a last resort, a 10,000-ohm 25-watt wirewound resistor may be shunted across the grid coil, or grid tuning capacitor of a high powered stage. This strategy removed a keying "pop" that showed up in a commercial transmitter, operating at a plate voltage of 5000.

Test for Parasitic Tendency in Tetrode Amplifiers

In most high-frequency transmitters there are a great many resonances in the tank circuit at frequencies other than the desired operating frequency. Most of these parasitic resonant circuits are not coupled to the tube and have no significant tendency to oscillate. A few, however, are coupled to the tube in some form of oscillatory circuit. If the regeneration is great enough, oscillation at the

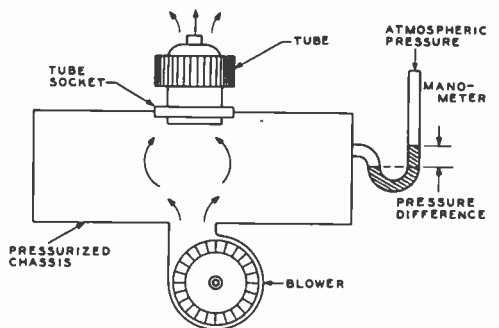

Figure 20

FORCED-AIR COOLING SYSTEM

Centrifugal blower pressurizes plenum chamber (air-tight chassis) and air is exhausted through the tube socket and anode cooler of vacuum tube. Pressure difference between plenum chamber and atmosphere is measured with manometer tube.

parasitic frequency results. Those spurious circuits existing just below oscillation must be found and suppressed to a safe level.

One test method is to feed a signal from a grid-dip oscillator into the grid of a stage and measure the resulting signal level in the plate circuit of the stage, as shown in figure 19. The test is made with all operating voltages applied to the tubes. Class-C stages should have bias reduced so a reasonable amount of static plate current flows. The grid-dip oscillator is tuned over the range of 100 kHz to 200 MHz, the relative level of the r-f voltmeter is watched, and the frequencies at which voltage peaks occur are noted. Each significant peak in voltage gain in the stage must be investigated. Circuit changes or suppression must then be added to reduce all peaks by 10 db or more in amplitude.

17-10 Forced-Air Cooling

A large percentage of the primary power drain of a transmitter is converted to heat emitted by tubes and components. The resulting temperature rise must be held within reasonable limits to ensure satisfactory life for the equipment.

Forced-air-cooled systems may be used to remove excess heat. A typical system consists of an *air blower*, a *conduit* to guide the air to the tube or component, a *heat radia-*

TUBE TYPE	AIR CFM	BACK PRESSURE	BLOWER SIZE	RPM	SOCKET CHIMNEY
3-400Z 3-500Z	13	0.20	3	1800	SK410 SK416 SK406
3-1000Z	25	0.64	3 3/4 2 1/2	3000 6000	SK510 SK516
4-1000A	25	0.64	3 3/4 2 1/2	3000 6000	SK510 SK506
4CX250B	6.4	1.12	2 1/2	6000	SK600 SK606
4CX1000A 4CX1500B	2.2	0.3	3	3100	SK600 SK606
5CX1500A	4.7	1.12	3	6000	SK640 SK606

Figure 21

COOLING REQUIREMENTS FOR TRANSMITTING TUBES

Air-system sockets and chimneys are required for high-power transmitting tubes. Complete air-cooling data for these types may be obtained from Application Engineering Department, Eimac Division of Varian, San Carlos, Calif. 94070.

tor on the component, and an air exhaust exit. The resistance to the air passage through such a system is termed system back pressure, pressure drop, or static pressure. Air requirements are normally expressed as a pressure drop defined in inches of water (as measured by a manometer) with a corresponding volumetric air flow defined in cubic feet per minute (c.f.m.). A typical air-cooling system is shown in figure 20. Cooling requirements for most transmitting tubes are provided on the data sheet and air requirements and blower data for some popular tubes are given in figure 21.

Radio Interference

The problem of interference to other equipment is best approached by the philosophy discussed in Chapter Seventeen. By correct design procedure, spurious harmonic generation in radio transmitters may be held to a minimum. The remaining problem is twofold: to make sure that the residual harmonics generated by the transmitter are not radiated, and to make sure that the fundamental signal of the transmitter does not overload the other equipment by reason of the proximity of one to the other.

In an area of high TV-signal field intensity the TVI problem is capable of complete solution with routine measures both at the amateur transmitter and at the affected receivers. But in fringe areas of low TV-signal field strength the complete elimination of TVI is a difficult and challenging problem. The fundamentals illustrated in Chapter Seventeen must be closely followed, and additional antenna filtering of the transmitter is required.

18-1 Types of Television Interference

There are three main types of TVI which may be caused singly or in combination by the emissions from an amateur transmitter.

These types of interference are:

1. Overloading of the TV set by the transmitter fundamental
2. Impairment of the picture by spurious emissions
3. Impairment of the picture by the radiation of harmonics

TV-Set Overload Even if the amateur transmitter were perfect and had no harmonic radiation or spurious emissions whatever, it still would be likely to cause overloading to TV sets whose antennas were within a few hundred feet of the transmitting antenna. This type of overloading is essentially the same as the common type of BCI encountered when operating a medium-power or high-power amateur transmitter within a few hundred feet of the normal broadcast receiver. The field intensity in the immediate vicinity of the transmitting antenna is sufficiently high so that the amateur signal will get into the BC or TV set either through overloading of the front end, or through the i-f, video, or audio systems. A characteristic of this type of interference is that it always will be eliminated when the transmitter temporarily is operated into a dummy antenna. Another characteristic of this type of overloading is that its effects

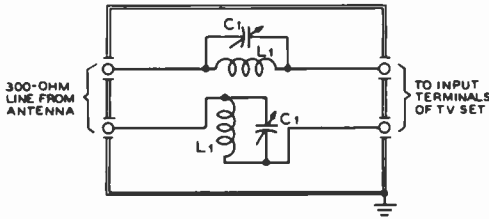

Figure 1

TUNED TRAP FOR THE TRANSMITTER FUNDAMENTAL

This trap has proven to be effective in eliminating the condition of general blocking as caused by a 50-MHz transmitter in the vicinity of a TV receiver. The tuned circuits L_1, C_1 are resonated separately to the frequency of transmission. The adjustment may be done at the station, or it may be accomplished at the TV receiver by tuning for minimum interference on the TV screen.

will be substantially continuous over the entire frequency coverage of the BC or TV receiver. Channels 2 through 13 will be affected in approximately the same manner.

With the overloading type of interference, the problem is simply to keep the *fundamental* of the transmitter out of the affected receiver. Other types of interference may or may not show up when the fundamental is taken out of the TV set (they probably will appear), but at least the fundamental *must* be eliminated first.

The elimination of the transmitter fundamental from the TV set is normally the only operation performed on or in the vicinity of the TV receiver. After the fundamental has been eliminated as a source of interference to reception, work may then be begun on or in the vicinity of the transmitter toward eliminating the other two types of interference.

Taking Out the Fundamental Signal More or less standard BCI-type practice is most commonly used in taking out fundamental interference.

Wavetraps and filters are installed, and the antenna system may or may not be modified so as to offer less response to the signal from the amateur transmitter. In regard to a comparison between wavetraps and filters, the same considerations apply as have been effective in regard to BCI for many years; wavetraps are quite effective when properly installed and adjusted, but they must be

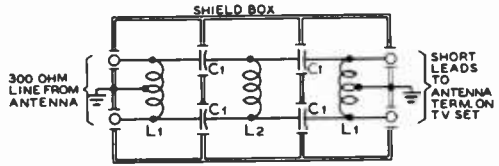

(A) FOR 300-OHM LINE, SHIELDED OR UNSHIELDED

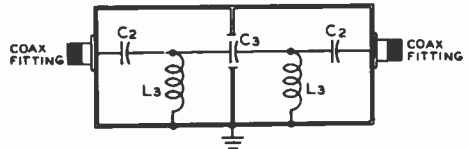

(B) FOR 50-75 OHM COAXIAL LINE

Figure 2

HIGH-PASS TRANSMISSION LINE FILTERS

The arrangement at A will stop the passing of all signals below about 45 MHz from the antenna transmission line into the TV set. Coils L_1 are each 1.2 microhenrys (17 turns No. 24 enam. closewound on 1/4-inch dia. polystyrene rod) with the center tap grounded. It will be found best to scrape, twist, and solder the center tap before winding the coil. The number of turns each side of the tap may then be varied until the tap is in the exact center of the winding. Coil L_2 is 0.6 microhenry (12 turns No. 24 enam. closewound on 1/4-inch dia. polystyrene rod). The capacitors should be about 16.5 pf, but either 15- or 20-pf ceramic capacitors will give satisfactory results. A similar filter for coaxial antenna transmission line is shown at B. Both coils should be 0.12 microhenry (7 turns No. 18 enam. spaced to 1/2 inch on 1/4-inch dia. polystyrene rod). Capacitors C_1 should be 75-pf midget ceramics, while C_2 should be a 40-pf ceramic.

readjusted whenever the band of operation is changed, or even when moving from one extreme end of a band to the other. Hence, wavetraps are not recommended except when operation will be confined to a relatively narrow portion of one amateur band. However, figure 1 shows a suitable trap system, especially effective at 50 MHz.

High-Pass Filters High-pass filters in the antenna lead of the TV set have proven to be quite satisfactory as a means of eliminating TVI of the overloading type. In many cases when the interfering transmitter is operated only on the bands below 30 MHz, the use of a high-pass filter in the antenna lead has completely eliminated all TVI. In some cases the installation of a high-pass filter in the antenna

transmission line and an a-c line filter of a standard variety has proven to be completely effective in eliminating the interference from a transmitter operating in one of the high-frequency amateur bands.

Designs for high-pass filters are given in figures 2 and 3. In most cases the filters may be constructed in one of the small shield boxes which are on the market. Input and output terminals may be standard connectors, or the inexpensive type of terminal strips usually used on BC and TV sets may be employed. Coaxial terminals should of course be employed when a coaxial feed line is used to the antenna. In any event, the leads from the filter box to the TV set should be very short, including both the antenna lead and the ground lead to the box itself. If the leads from the box to the set have much length, they may pick up enough signal to nullify the effects of the high-pass filter.

Blocking from 50-MHz Signals

Operation on the 50-Mc. amateur band in an area where channel 2 is in use for TV imposes a special problem in the matter of blocking. The input circuits of most TV sets are sufficiently broad so that an amateur signal on the 50-MHz band will ride through with little attenuation. Also, the normal TV antenna will have quite a large response to a signal in the 50-MHz band, since the lower limit of channel 2 is 54-MHz.

High-pass filters of the normal type simply are not capable of giving sufficient attenuation to a signal whose frequency is so close to the necessary passband of the filter. Hence, a resonant circuit element, as illustrated in figure 1, must be used to trap out the amateur field at the input of the TV set. The transmitter operating frequency will have to be near the lower frequency limit of the 50-MHz band to obtain adequate rejection of the amateur signal while still not materially affecting the response of the receiver to channel 2.

Elimination of Spurious Emissions All spurious emissions from amateur transmitters (ignoring harmonic signals for the time being) must be eliminated to comply with FCC regulations. But in the past many amateur transmitters have

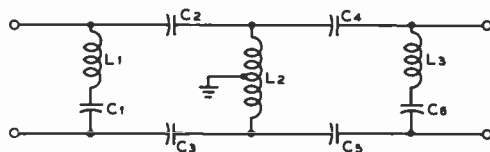

Figure 3

SERIES-DERIVED HIGH-PASS FILTER

This filter is designed for use in the 300-ohm transmission line from the TV antenna to the TV receiver. Nominal cut-off frequency is 36 MHz and maximum rejection is at about 29 MHz.

C_1, C_2 —15-pf zero-coefficient ceramic

C_3, C_4, C_5, C_6 —20-pf zero-coefficient ceramic

L_1, L_2 —2.0 μ h. About 24 turns No. 28 d.c.c. wound to $\frac{3}{8}$ " on $\frac{1}{4}$ " diameter polystyrene rod. Turns should be adjusted until the coil resonates to 29 MHz with the associated 15-pf capacitor.

L_3 —0.66 μ h. 14 turns No. 28 d.c.c. wound to $\frac{3}{8}$ " on $\frac{1}{4}$ " dia. polystyrene rod. Adjust turns to resonate externally to 20 MHz with an auxiliary 100-pf capacitor whose value is accurately known.

emitted spurious signals as a result of key clicks, parasitics, and overmodulation transients. In most cases the operators of the transmitters were not aware of these emissions since they were radiated only for a short distance and hence were not brought to his attention. But with one or more TV sets in the neighborhood it is probable that such spurious signals will be brought quickly to the attention of the operator.

18-2 Harmonic Radiation

After any condition of blocking at the TV receiver has been eliminated, and when the transmitter is completely free of transients and parasitic oscillations, it is probable that TVI will be eliminated in certain cases. Certainly general interference should be eliminated, particularly if the transmitter is a well-designed affair operated on one of the lower frequency bands, and the station is in a high-signal TV area. But when the transmitter is to be operated on one of the higher frequency bands, and particularly in a marginal TV area, the job of TVI-proofing will just have begun. The elimination of harmonic radiation from the transmitter is a difficult and tedious job which must be done in an orderly manner if completely satisfactory results are to be obtained.

First it is well to become familiar with the

TRANSMITTER FUNDAMENTAL	2ND	3RD	4TH	5TH	6TH	7TH	8TH	9TH	10TH
7.0-7.3		21-21.9 TV I.F.			42-44 TV I.F.		56-58.4 CHANNEL ①	63-65.7 CHANNEL ①	70-73 CHANNEL ①
14.0-14.35		42-43 TV I.F.	56-57.6 CHANNEL ②	70-72 CHANNEL ①	84-86.4 CHANNEL ①	98-100.8 F-M BROADCAST			
21.0-21.45		63-64.35 CHANNEL ①	84-85.8 CHANNEL ①	105-107.25 F-M BROADCAST				189-193 CHANNELS ① ②	210-214.5 CHANNEL ②
28.0-29.7	56-59.4 CHANNEL ②	84-89.1 CHANNEL ①			168-178.2 CHANNEL ①	196-207.9 CHANNELS ② ③ ④			
50.0-54.0	100-108 F-M BROADCAST		200-216 CHANNELS ① ② ③				450-486 500-540 POSSIBLE INTERFERENCE TO UHF CHANNELS		

Figure 4

HARMONICS OF THE AMATEUR BANDS

Shown are the harmonic frequency ranges of the amateur bands between 7 and 54 MHz, with the TV channels (and TV i-f systems) which are most likely to receive interference from these harmonics. Under certain conditions amateur signals in the 1.8- and 3.5-MHz bands can cause interference as a result of direct pickup in the video systems of TV receivers which are not adequately shielded.

TV channels presently assigned, with the TV intermediate frequencies commonly used, and with the channels which will receive interference from harmonics of the various amateur bands. Figures 4 and 5 give this information.

Even a short inspection of figures 4 and 5 will make obvious the seriousness of the interference which can be caused by harmonics of amateur signals in the higher frequency bands. With any sort of reasonable precautions in the design and shielding of the transmitter it is not likely that harmonics higher than the 6th will be encountered. For this reason, the most frequently found offenders in the way of harmonic interference will almost invariably be those bands above 14 MHz.

Nature of Harmonic Interference Investigations into the nature of the interference caused by amateur signals on the TV screen, assuming that blocking has been eliminated as described earlier in this chapter, have revealed the following facts:

1. An unmodulated carrier, such as a c-w signal with the key down or an a-m signal without modulation, will give a crosshatch or herringbone pattern on the TV screen. This same general type of picture also will occur in the case of a narrow-band f-m signal either with or without modulation.
2. A relatively strong a-m or SSB signal will give in addition to the herringbone a very serious succession of light and dark bands across the TV picture.
3. A moderate strength c-w signal without transients, in the absence of overloading of the TV set, will result merely in the turning on and off of the herringbone on the picture.

To discuss condition 1 above, the herringbone is a result of the beat note between the TV video carrier and the amateur harmonic. Hence the higher the beat note the less obvious will be the resulting crosshatch. Further, it has been shown that a much stronger signal is required to produce a discernible herringbone when the interfering harmonic is as far away as possible from the video car-

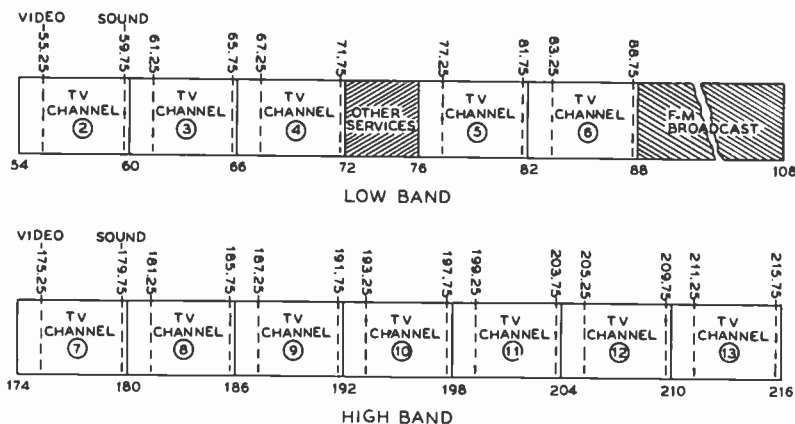

Figure 5

FREQUENCIES OF THE VHF TV CHANNELS

Showing the frequency ranges of TV channels 2 through 13, with the picture carrier and sound carrier frequencies also shown.

rier, without running into the sound carrier. Thus, as a last resort, or to eliminate the last vestige of interference after all corrective measures have been taken, operate the transmitter on a frequency such that the interfering harmonic will fall as far as possible from the picture carrier. The worst possible interference to the picture from a continuous carrier will be obtained when the interfering signal is very close in frequency to the video carrier.

Isolating the Source of the Interference

Throughout the testing procedure it will be necessary to have some sort of indicating device as a means of determining harmonic field intensities. The best indicator, of course, is a nearby television receiver. The home receiver may be borrowed for these tests. A portable "rabbit ears" antenna is useful since it may be moved about the transmitter site to examine the intensity of the interfering harmonics.

The first step is to turn on the transmitter and check all TV channels to determine the extent of the interference and the number of channels affected. Then disconnect the transmitting antenna and substitute a shielded dummy load, noting the change in interference level, if any. Now, remove excitation from the final stage of the transmitter, and determine the extent of interference caused by the exciter stages.

In most cases, it will be found that the interference drops materially when the transmitting antenna is removed and a dummy load substituted. It may also be found that the interference level is relatively constant, regardless of the operation of the output stage of the transmitter. In rare cases, it may be found that a particular stage in the transmitter is causing the interference and corrective measures may be applied to this stage. The common case, however, is general TVI radiating from antenna, cabinet, and power leads of the transmitter.

The first corrective measure is to properly bypass the transmitter power leads before they leave the cabinet. Each lead should be bypassed to chassis ground with a $.01\text{-}\mu\text{fd}$, 1.6-KV ceramic capacitor, or run through a $0.1\text{-}\mu\text{fd}$, 600-volt feedthrough (*Bypass*) capacitor. If possible, the transmitter chassis should be connected to an external ground.

The next step is to check transmitter shielding. Paint should be removed from mating surfaces wherever possible and the cabinet should be made as "r-f tight" as possible in the manner discussed in Chapter 32.

18-3 Low-Pass Filters

After the transmitter has been shielded, and all power leads have been filtered in such a manner that the transmitter shielding has

not been rendered ineffective, the only remaining available exit for harmonic energy lies in the antenna transmission line. Hence the main burden of harmonic attenuation will fall on the low-pass filter installed between the output of the transmitter and the antenna system.

Experience has shown that the low-pass filter can best be installed externally to the main transmitter enclosure, and that the transmission line from the transmitter to the lowpass filter should be of the coaxial type. Hence the majority of low-pass filters are designed for a characteristic impedance of 52 chms, so that RG-8/U cable (or RG-58/U for a small transmitter) may be used between the output of the transmitter and the antenna transmission line or the antenna tuner.

Transmitting-type low-pass filters for amateur use usually are designed in such a manner as to pass frequencies up to about 30 MHz without attenuation. The nominal cutoff frequency of the filters is usually between 38 and 45 MHz, and *m*-derived sections with maximum attenuation in channel 2 usually are included. Well-designed filters capable of carrying any power level up to one kilowatt are available commercially from several manufacturers. Alternatively, filters in kit form are available from several manufacturers at a somewhat lower price. Effective filters may be home constructed, if the test equipment is available and if sufficient care is taken in the construction of the assembly.

Construction of Figures 6 and 7, illustrate Low-Pass Filters high-performance low-pass filters which are suitable for home construction. All are constructed in slip-cover aluminum boxes with dimensions of 17 by 3 by 2 5/8 inches. Five aluminum baffle plates have been installed in the chassis to make six shielded sections within the enclosure. Feedthrough bushings between the shielded sections are *Johnson No. 135-55*.

Both the A and B filter types are designed for a nominal cutoff frequency of 45 MHz, with a frequency of maximum rejection at about 57 MHz as established by the terminating half-sections at each end. Characteristic impedance is 52 ohms in all cases. The alternative filter designs diagramed in fig-

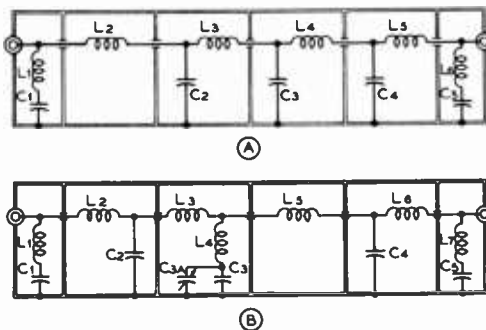

Figure 6

LOW-PASS FILTER SCHEMATIC DIAGRAMS

The filter illustrated at A uses *m*-derived terminating half sections at each end, with three constant-*k* midsections. The filter at B is essentially the same except that the center section has been changed to act as an *m*-derived section which can be designed to offer maximum attenuation to channels, 2, 4, 5, or 6 in accord with the constants given below. Cutoff frequency is 45 MHz in all cases. All coils, except *L*₁, in B above, are wound 1/2" I.d. with 8 turns per inch.

The A Filter

- C*₁, *C*₂—41.5 pf (40 pf will be found suitable.)
- C*₃, *C*₄, *C*₅—136 pf (130 to 140 pf may be used.)
- L*₁, *L*₂—0.2 μh; 3 1/2 t. No. 14
- L*₃, *L*₄—0.3 μh; 5 t. No. 12
- L*₅, *L*₆—0.37 μh; 6 1/2 t. No. 12

The B Filter with midsection tuned to Channel 2 (58 MHz)

- C*₁, *C*₂—41.5 pf (use 40 pf)
- C*₃, *C*₄—136 pf (use 130 to 140 pf)
- C*₅—87 pf (50 pf fixed and 75 pf variable in parallel.)
- L*₁, *L*₂—0.2 μh; 3 1/2 t. No. 14
- L*₃, *L*₄, *L*₅—0.3 μh; 5 t. No. 12
- L*₆—0.09 μh; 2 t. No. 14, 1/2" dia. 1/4" long

The B Filter with midsection tuned to Channel 4 (71 MHz) All components same except that:

- C*₅—106 pf (use 100 pf)
- L*₆, *L*₇—0.33 μh; 6 t. No. 12
- L*₈—0.05 μh; 1 1/2 t. No. 14, 3/8" dia. by 3/8" long.

The B Filter with midsection tuned to Channel 5 (81 MHz). Change the following:

- C*₅—113 pf (use 115 pf)
- L*₆, *L*₇—0.34 μh; 6 t. No. 12
- L*₈—0.033 μh; 1 t. No. 14, 3/8" dia.

The B Filter with midsection tuned to Channel 6 (86 MHz). All components are essentially the same except that the theoretical value of *L*₈ is changed to 0.03 μh, and the capacitance of *C*₅ is changed to 117 pf. (use 120 pf)

ure 6B have provisions for an additional rejection trap in the center of the filter unit which may be designed to offer maximum rejection in channel 2, 4, 5, or 6, depending on which channel is likely to be received in the area in question. The only components which must be changed when changing the frequency of the maximum rejection notch in

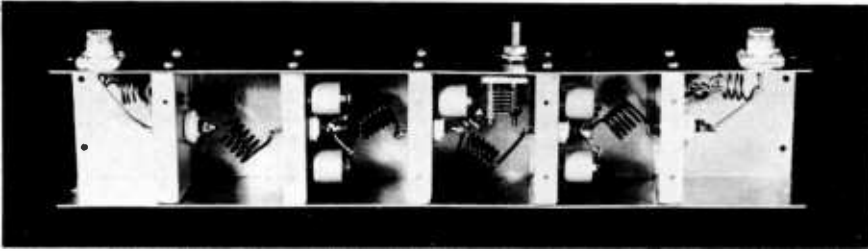

Figure 7
PHOTOGRAPH OF THE B FILTER WITH COVER REMOVED

The midsection in this filter is adjusted for maximum rejection of channel 4. Note that the main coils of the filter are mounted at an angle of about 45 degrees so that there will be minimum inductive coupling from one section to the next through the holes in the aluminum partitions. Mounting the coils in this manner was found to give a measurable improvement in the attenuation characteristics of the filter.

the center of the filter unit are inductors L_3 , L_4 , and L_5 and capacitor C_3 . A trimmer capacitor has been included as a portion of C_3 so that the frequency of maximum rejection can be tuned accurately to the desired value. Reference to figures 4 and 5 will show the amateur bands which are most likely to cause interference to specific TV channels.

Either high-power or low-power components may be used in the filters diagramed in figure 6. With the small zero-coefficient ceramic capacitors used in the filter units of figure 6A or figure 6B, power levels up to 200 watts output may be used without danger of damage to the capacitors, *provided* the filter is feeding a 52-ohm resistive load. It may be practical to use higher levels of power with this type of ceramic capacitor in the filter, but at a power level of 200 watts on the 28-MHz band the capacitors run just perceptibly warm to the touch. As a point of interest, it is the current rating which is of significance in the capacitors used in filters such as illustrated. Since current ratings for small capacitors such as these are not readily available, it is not possible to establish an accurate power rating for such a unit. The high-power unit illustrated in figure 7, which uses *Centralab type 850S* and *854S* capacitors, has proven quite suitable for power levels up to 2 kW, PEP.

Capacitors C_1 , C_2 , C_4 , and C_5 can be standard manufactured units with normal 5 percent tolerance. The coils for the end sec-

tions can be wound to the dimensions given (L_1 , L_6 , and L_7). Then the resonant frequency of the series-resonant end sections should be checked with a grid-dip meter, after the adjacent input or output terminal has been shorted with a very short lead. The coils should be squeezed or spread until resonance occurs at 57 MHz.

The intermediate *m*-derived section in the filter of figure 6B may also be checked with a grid-dip meter for resonance at the correct rejection frequency, after the hot end of L_1 has been temporarily grounded with a low-inductance lead. The variable-capacitor portion of C_3 can be tuned until resonance at the correct frequency has been obtained. Note that there is so little difference between the constants of this intermediate section for channels 5 and 6 that variation in the setting of C_3 will tune to either channel without materially changing the operation of the filter.

The coils in the intermediate sections of the filter (L_2 , L_3 , L_4 , and L_5 in figure 6A, and L_2 , L_3 , L_5 , and L_6 in figure 6B) may be checked most conveniently outside the filter unit with the aid of a small ceramic capacitor of known value and a grid-dip meter. The ceramic capacitor is paralleled across the small coil with the shortest possible leads. Then the assembly is placed on a cardboard box and the resonant frequency checked with a grid-dip meter.

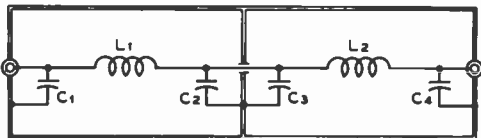

Figure 8

SCHEMATIC OF THE SINGLE-SECTION HALF-WAVE FILTER

The constants given below are for a characteristic impedance of 52 ohms, for use with RG-8/U and RG-58/U cable. Coil L_1 should be checked for resonance at the operating frequency with C_1 and the same with L_2 and C_2 . This check can be made by soldering a low-inductance grounding strap to the lead between L_1 and L_2 , where it passes through the shield. When the coils have been trimmed to resonance with a grid-dip meter, the grounding strap should of course be removed. This filter type will give an attenuation of about 30 db to the second harmonic, about 48 db to the third, about 60 db to the fourth, 67 to the fifth, etc., increasing at a rate of about 30 db per octave.

C_1, C_2, C_3, C_4 —Silver mica or small ceramic for low power, transmitting type ceramic for high power. Capacitance for different bands is given below.

- 160 meters—1700 pf
- 80 meters—850 pf
- 40 meters—440 pf
- 20 meters—220 pf
- 10 meters—110 pf
- 6 meters—60 pf

L_1, L_2 —May be made up of sections of B&W Miniductor for power levels below 250 watts, or of No. 12 enam. for power up to one kilowatt. Approximate dimensions for the coils are given below, but the coils should be trimmed to resonate at the proper frequency with a grid-dip meter as discussed above. All coils except the ones for 160 meters are wound 8 turns per inch.

- 160 meters—4.2 μ h; 22 turns No. 16 enam. 1" dia. 2" long
- 80 meters—2.1 μ h; 13 t. 1" dia. (No. 3014 Miniductor or No. 12 at 8 t.p.i.)
- 40 meters—1.1 μ h; 8 t. 1" dia. (No. 3014 or No. 12 at 8 t.p.i.)
- 20 meters—0.55 μ h; 7 t. 3/4" dia. (No. 3010 or No. 12 at 8 t.p.i.)
- 10 meters—0.3 μ h; 6 t. 1/2" dia. (No. 3002 or No. 12 at 8 t.p.i.)
- 6 meters—0.17 μ h; 4 t. 1/2" dia. (No. 3002 or No. 12 at 8 t.p.i.)

Using Low-Pass Filters

The low-pass filter connected in the output transmission line of the transmitter is capable of affording an enormous degree of harmonic attenuation. However, the filter must be operated in the correct manner or the results obtained will not be up to expectations.

In the first place, all direct radiation from the transmitter and its control and power

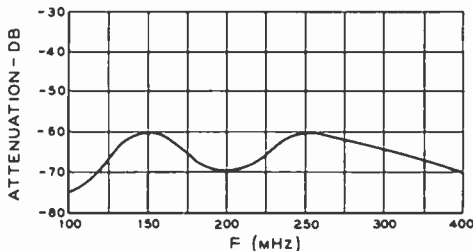
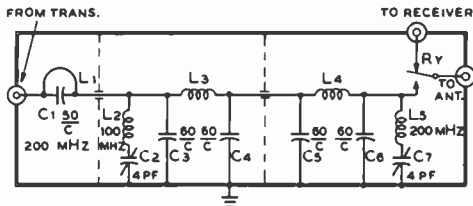

Figure 9

SIX METER TVI FILTER

C_1 —50-pf Centralab 850S-50Z. Resonates with L_1 to 200 MHz.

C_2, C_4 —4-pf piston capacitor. JFD type VC-4G.

C_3, C_5, C_6, C_7 —60 pf. Three 20-pf capacitors in parallel. Centralab 853A-20Z.

L_1 —Copper strap, 1/2" wide, 2 1/4" long, 1 7/8" between mounting holes, approximately 0.01" thick. Strap is bent in U-shape around capacitor and bolted to capacitor terminals.

L_2 —11 turns #18 enam. wire, 1/4" diameter, 3/4" long, airwound. Resonates to 100 MHz with capacitor C_2 .

L_3, L_4 —3 turns 3/16" tubing, 1/4" i.d., spaced to occupy about 2 1/2". Turns are adjusted to resonate each section at 50 MHz.

L_5, L_6 —6 turns #18 enam. wire, 1/4" diameter, 3/8" long, airwound. Resonates to 200 MHz with capacitor C_5 .

leads must be suppressed. This subject has been discussed in the previous section. Secondly, the filter must be operated into a load impedance approximately equal to its design characteristic impedance. The filter itself will have very low losses (usually less than 0.5 db) when operated into its nominal value of resistive load. But if the filter is not terminated correctly, its losses will become excessive, and it will not present the correct value of load impedance to the transmitter.

If a filter, being fed from a high-power transmitter, is operated into an incorrect termination it may be damaged; the coils may be overheated and the capacitors destroyed as a result of excessive r-f currents. Hence it is wise when first installing a low-pass filter, to check the standing-wave ratio of the load being presented to the output of the

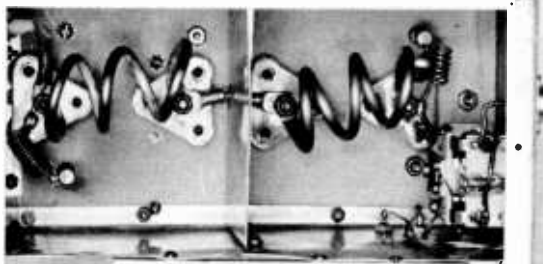

Figure 10

INTERIOR VIEW OF SIX-METER FILTER

The input compartment of the filter is at the left. The series coil is wound of copper tubing, and the connection to the output section (right) is made by a length of tubing which passes through a hole in the center shield. Series elements carry less current and employ wirewound coils. At right is antenna relay, with power leads bypassed as they leave filter compartment. Filter is set to correct frequency by adjusting the inductance of the tubing coils.

filter with a standing-wave meter of any of the conventional types. Then the antenna termination or the antenna coupling should be adjusted, with low power on the transmitter, until the s.w.r. of the load being presented to the filter is less than 2.0, and preferably below 1.5.

Half-Wave Filters A *half-wave filter* is an effective device for TVI suppression and is easily built. It offers the advantage of presenting the same value of impedance at the input terminal as appears as a load across the output terminal. The filter is a single-band unit, offering high attenuation to the second- and higher-order harmonics. Design data for high-frequency half-wave filters is given in figure 8.

A High-Power Filter for Six Meters The second and higher harmonics of a six-meter transmitter fall directly into the f-m and uhf and vhf television bands. An effective low-pass filter is required to adequately suppress unwanted transmitter emissions falling in these bands. Described in this section is a six-meter TVI filter rated at the two-kilowatt level which provides better than 75 decibels suppression of the second harmonic and better than 60 decibels suppression of higher harmonics of a six-meter transmitter (figure 9). The unit is composed of a half-wave filter with added end sections which are tuned to 100 MHz and 200 MHz. An auxiliary filter element in series with the input is tuned to

200 MHz to provide additional protection to television channels 11, 12, and 13.

The filter (figure 10) is built in an aluminum box measuring 4" x 4" x 10" and uses *type-N* coaxial fittings. The half-wave filter coils are wound of 3/16-inch diameter copper tubing and have large copper lugs soldered to the ends. The 60-pf capacitors are made up of three 20-pf, 5kv ceramic units in parallel. A small sheet of copper is cut in triangular shape and joins the capacitor terminals and a coil lug is attached to the center of the triangle with heavy brass bolts.

The parallel-tuned 200-MHz series filter element at the input terminal is made of a length of copper strap shunted across a 50-pf, 5kv ceramic capacitor. In this particular filter, the parallel circuit was affixed to the output capacitor of the pi-network tank circuit of the transmitter and does not show in the photograph.

The filter is adjusted by removing the connections from the ends of the half-wave sections and adjusting each section to 50 MHz by spreading the turns of the coil with a screwdriver while monitoring the resonant frequency with a grid-dip oscillator. The next step is to ground the top end of each series-tuned section (C_2 , L_2 and C_7 , L_5) with a heavy strap. The input section is tuned to 100 MHz and the output section to 200 MHz. When tuning adjustments are completed, the straps are removed and the top of the filter box is held in place with sheet-metal screws.

18-4 Broadcast Interference

Interference to the reception of signals in the broadcast band (540 to 1600 kHz) or in the f-m broadcast band (88 to 108 MHz) by amateur transmissions is a serious matter to those amateurs living in densely populated areas. Although broadcast interference has recently been overshadowed by the seriousness of television interference, the condition of BCI is still present.

In general, signals from a transmitter operating properly are not picked up by receivers tuned to other frequencies unless the receiver is of inferior design, or is in poor condition. Therefore, if the receiver is of good design and is in good repair, the burden of rectifying the trouble rests with the owner of the interfering station. Phone and c-w stations both are capable of causing broadcast interference, key-click annoyance from the code transmitters being particularly objectionable.

Broadcast interference, as covered in this section refers primarily to standard (amplitude-modulated, 550-1600 kHz) broadcast. Interference with f-m broadcast reception is much less common, due to the wide separation in frequency between the f-m broadcast band and the more popular amateur bands, and due also to the limiting action which exists in all types of f-m receivers. Occasional interference with f-m broadcast by a harmonic of an amateur transmitter has been reported; if this condition is encountered, it may be eliminated by the procedures discussed in the first portion of this chapter under *Television Interference*.

Interference Depending on whether it is traceable directly to causes within the *station* or within the *receiver*, broadcast interference may be divided into two main classes. For example, that type of interference due to transmitter overmodulation or flat-topping is at once listed as being caused by improper operation, while an interfering signal that tunes in and out with a broadcast station is probably an indication of cross-modulation or image response in the receiver, and the poorly designed input stage of the receiver is held liable. The various types of interference and

recommended cures will be discussed in the following paragraphs.

Blanketing This is not a tunable effect, but a total blocking of the receiver. A more or less complete "washout" covers the entire receiver range when the carrier is switched on. This produces either a complete blotting out of all broadcast stations, or else knocks down their volume several decibels—depending on the severity of the interference. Voice modulation causing the blanketing will be highly distorted or even unintelligible. Keying of the carrier which produces the blanketing will cause an annoying fluctuation in the volume of the broadcast signals.

Blanketing generally occurs in the immediate neighborhood (inductive field) of a powerful transmitter, the affected area being directly proportional to the power of the transmitter. Also, it is more prevalent with transmitters which operate in the 160-meter and 80-meter bands, as compared to those operating on the higher frequencies.

In the rare case where the broadcast receiver utilizes an external antenna, a simple wavetrap tuned to the frequency of the local transmitter will minimize the signal entering the receiver (figure 11). The wavetrap should be installed as close to the receiver antenna terminal as practical. Most broadcast receivers, however, dispense with an external antenna and instead use a ferrite "loopstick" antenna concealed within the receiver cabinet. Loopstick pickup at the higher frequencies is quite restricted and it is usually found that severe blanketing may be reduced by merely bypassing each side of the receiver power line to the chassis of the receiver with a pair of .01- μ fd, 1.6-kV ceramic disc capacitors.

Phantoms With two strong local carriers applied to a nonlinear impedance, the beat note resulting from cross modulation between them may fall on some frequency within the broadcast band and will be audible at that point. If such a "phantom" signal falls on a local broadcast frequency, there will be heterodyne interference as well. This is a common occurrence with broadcast receivers in the neighborhood of two amateur stations, or an amateur and a broadcast station. It also sometimes occurs

1.8 MHz	1 inch No. 30 enam. closewound on 1" form	75-pf var.
3.5 MHz	42 turns No. 30 enam. closewound on 1" form	50-pf var.
7.0 MHz	23 turns No. 24 enam. closewound on 1" form	50-pf var.
14 MHz	10 turns No. 24 enam. closewound on 1" form	50-pf var.
21 MHz	7 turns No. 24 enam. closewound on 1" form	50-pf var.
28 MHz	4 turns No. 24 enam. closewound on 1" form	25-pf var.
50 MHz	3 turns No. 24 enam. spaced 1/2" on 1" form	25-pf var.

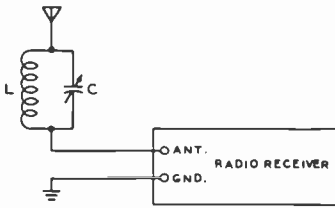

Figure 11

WAVETRAP FOR BCI

If the radio receiver has an external antenna, a parallel-tuned circuit may be placed at the antenna terminal and tuned to the frequency of the offending signal. Table shows circuit constants for amateur-band wavetraps.

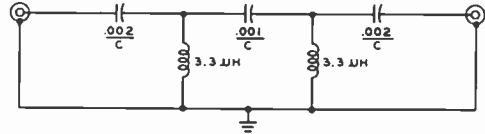

Figure 12

HYPASS FILTER FOR AMATEUR RECEIVER

This simple filter attenuates signals below 1600 kHz to reduce overload caused by strong nearby broadcast station. Filter is designed to be placed in series with coaxial line to receiver. Filter should be built in small shield box with appropriate coaxial fittings. J. W. Miller ferrite choke 74F336AP may be used for 3.3 μH inductor.

a simple superhet receiver and cause interference of the untunable variety if the manufacturer has not provided an i-f wavetrapp in the antenna circuit.

This particular type of phantom may, in addition to causing i-f interference, generate harmonics which may be tuned in and out with heterodyne whistles from one end of the receiver dial to the other. It is in this manner that *birdies* often result from the operation of nearby amateur stations.

When one component of a phantom is a steady unmodulated carrier, only the intelligence presence on the other carrier is conveyed to the broadcast receiver.

Phantom signals almost always may be identified by the suddenness with which they are interrupted, signaling withdrawal of one party of the union. This is especially baffling to the inexperienced interference locator, who observes that the interference suddenly disappears, even though his own transmitter remains in operation.

If the mixing or rectification is taking place in the receiver itself, a phantom signal may be eliminated by removing either one of the contributing signals from the receiver input circuit. In the case of phantom cross-talk in an amateur-band receiver, a simple high-pass filter designed to attenuate signals below 1600 kHz may be placed in the coaxial antenna lead to the receiver (figure 12). This will greatly reduce the strength of local broadcast signals, which in a metropolitan area may amount to fractions of a volt on the receiver input circuit.

when one of the stations is located in the immediate vicinity.

As an example: an amateur signal on 3514 kHz might beat with a local 2414 kHz carrier to produce a 1100-kHz phantom. If the two carriers are strong enough in the vicinity of a circuit which can cause rectification, the 1100-kHz phantom will be heard in the broadcast band. A poor contact between two oxidized wires can produce rectification.

Two stations must be transmitting simultaneously to produce a phantom signal; when either station goes off the air the phantom disappears. Hence, this type of interference is apt to be reported as highly intermittent and might be difficult to duplicate unless a test oscillator is used "on location" to simulate the missing station. Such interference cannot be remedied at the transmitter, and often the rectification takes place some distance from the receivers. In such occurrences it is most difficult to locate the source of the trouble.

It will also be apparent that a phantom might fall on the intermediate frequency of

A-c/d-c Receivers Inexpensive table-model a-c/d-c receivers are particularly susceptible to interference from amateur transmissions. In most cases the receivers are at fault; but this does not absolve the amateur of his responsibility in attempting to eliminate the interference.

In cases of interference to inexpensive receivers, particularly those of the a-c/d-c type, it will be found that stray receiver rectification is causing the trouble. The offending stage usually will be found to be a high- μ triode as the first audio stage following the second detector. Tubes of this type are quite nonlinear in their grid characteristic, and hence will readily rectify any r-f signal appearing between grid and cathode. The r-f signal may get to the tube as a result of direct signal pickup due to the lack of shielding, but more commonly will be fed to the tube from the power line as a result of the series heater string.

The remedy for this condition is simply to ensure that the cathode and grid of the high- μ audio tube (usually a 6AV6 or equivalent) are at the same r-f potential. This is accomplished by placing an r-f bypass capacitor with the shortest possible leads directly from grid to cathode, and then adding an impedance in the lead from the volume control to the grid of the audio tube. The impedance may be an amateur band r-f choke (such as a National R-100U) for best results, but for a majority of cases it will be found that a 47,000-ohm $\frac{1}{2}$ -watt resistor in series with this lead will give satisfactory operation. Suitable circuits for such an operation on the receiver are given in figure 13.

In many a-c/d-c receivers there is no r-f bypass included across the plate-supply rectifier for the set. If there is an appreciable level of r-f signal on the power line feeding the receiver, r-f rectification in the power rectifier of the receiver can cause a particularly bad type of interference which may be received on other broadcast receivers in the vicinity in addition to the one causing the rectification. The soldering of a 0.01- μ fd, 1.6 kV disc ceramic capacitor directly from anode to cathode of the power rectifier (whether it is of the vacuum-tube or silicon-rectifier type) usually will bypass the r-f signal across the rectifier and thus eliminate the difficulty.

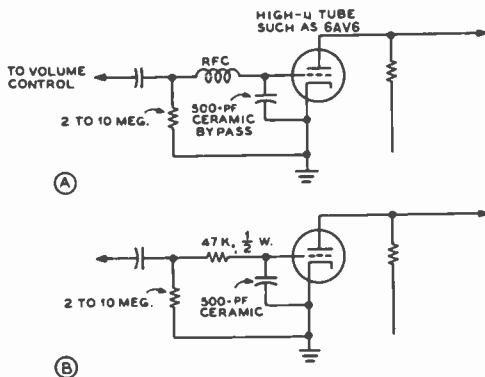

Figure 13

CIRCUITS FOR ELIMINATING AUDIO-STAGE RECTIFICATION

"Floating" Volume-Control Shafts Several sets have been encountered where there was only a slight interfering signal; but, on placing one's hand to the volume control, the signal would greatly increase. Investigation revealed that the volume control was installed with its shaft insulated from ground. The control itself was connected to a critical part of a circuit, in many instances to the grid of a high-gain audio stage. The cure is to install a volume control with *all* the terminals insulated from the shaft, and then to ground the shaft.

Image Interference In addition to those types of interference already discussed, there are two more which are common to superhet receivers. The prevalence of these types is of great concern to the amateur, although the responsibility for their existence more properly rests with the broadcast receiver.

The mechanism whereby image production takes place may be explained in the following manner: when the first detector is set to the frequency of an incoming signal, the high-frequency oscillator is operating on another frequency which differs from the signal by the number of kHz of the intermediate frequency. Now, with the setting of these two stages undisturbed, there is another signal which will beat with the high-frequency oscillator to produce an i-f signal. This other signal is the so-called *image*,

which is separated from the desired signal by twice the intermediate frequency.

Thus, in a receiver with a 175-kHz intermediate frequency tuned to 1000 kHz; the h-f oscillator is operating on 1175 kHz, and a signal on 1350 kHz (1000 kHz plus 2×175 kHz) will beat with this 1175 kHz oscillator frequency to produce the 175-kHz i-f signal. Similarly, when the same receiver is tuned to 1450 kHz, an amateur signal on 1800 kHz can come through.

If the image appears only a few Hz or kHz from a broadcast carrier, heterodyne interference will be present as well. Otherwise, it will be tuned in and out in the manner of a station operating in the broadcast band. Sharpness of tuning will be comparable to that of broadcast stations producing the same AVC voltage at the receiver.

The second variety of superhet interference is the result of harmonics of the receiver high-frequency oscillator beating with amateur carriers to produce the intermediate frequency of the receiver. The amateur transmitter will always be found to be on a frequency equal to some harmonic of the receiver hf oscillator, *plus or minus the intermediate frequency*.

As an example: when a broadcast superhet with 465-kHz intermediate frequency is tuned to 1000 kHz, its high-frequency oscillator operates on 1465 kHz. The third harmonic of this oscillator frequency is 4395 kHz, which will beat with an amateur signal on 3930 kHz to send a signal through the i-f amplifier. The 3930 kHz signal would be tuned in at the 1000-kHz point on the dial.

Some oscillator harmonics are so related to amateur frequencies that more than one point of interference will occur on the receiver dial. Thus, a 3500-kHz signal may be tuned in at six points on the dial of a nearby broadcast superhet having a 175-kHz intermediate frequency and no r-f stage.

Insofar as remedies for image and harmonic superhet interference are concerned, it is well to remember that *if* the amateur signal did not in the first place reach the input stage of the receiver, the annoyance would not have been created. It is therefore good policy to try to eliminate it by means of a wavetrapped or low-pass filter. Broadcast superhets are not always the acme of good shielding, however, and the amateur signal is apt

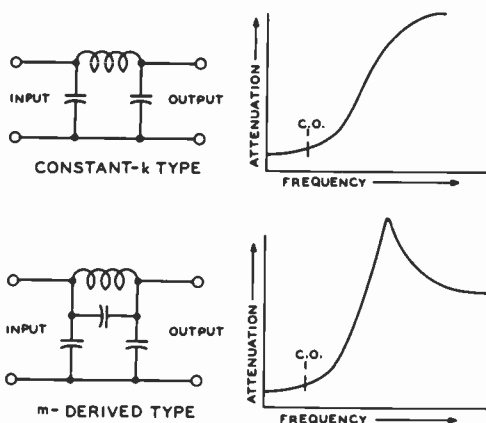

Figure 14

TYPES OF LOW-PASS FILTERS

Filters such as these may be used in the circuits between the antenna and the input of the receiver.

to enter the circuit through channels other than the input circuit. If a wavetrapped or filter will not cure the trouble, the only alternative will be to attempt to select a transmitter frequency such that neither image nor harmonic interference will be set up on favorite stations in the susceptible receivers. The equation given earlier may be used to determine the proper frequencies.

Low-Pass Filters The greatest drawback of the wavetrapped is the fact that it is a single-frequency device; i.e., it may be set to reject at one time only one frequency (or, at best, an extremely narrow band of frequencies). Each time the frequency of the interfering transmitter is changed, every wavetrapped tuned to it must be retuned. A much more satisfactory device is the *wave filter* which requires no tuning. One type, the low-pass filter, passes all frequencies below one critical frequency, and eliminates all higher frequencies. It is this property that makes the device ideal for the task of removing amateur frequencies from broadcast receivers.

A good low-pass filter designed for maximum attenuation around 1700 kHz will pass all broadcast carriers, but will reject signals originating in any amateur band. Naturally such a device should be installed only in

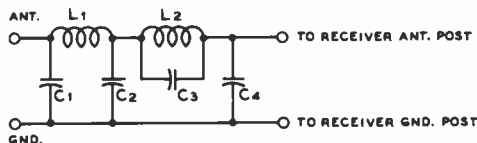

Figure 15

COMPOSITE LOW-PASS FILTER CIRCUIT

This filter is highly effective in reducing broadcast interference from all high-frequency stations, and requires no tuning. Constants for 400-ohm terminal impedance and 1600 kHz cutoff are as follows: L₁, 65 turns No. 22 d.c.c. closewound on 1½ in. dia. form. L₂, 41 turns ditto, not coupled to L₁. C₁, 250-pf fixed mica capacitor. C₂, 400-pf fixed mica capacitor. C₃ and C₄, 150-pf fixed mica capacitors, former of 5% tolerance. With some receivers, better results will be obtained with a 200-ohm carbon resistor inserted between the filter and antenna post on the receiver. With other receivers the effectiveness will be improved with a 600-ohm carbon resistor placed from the antenna post to the ground post on the receiver. The filter should be placed as close to the receiver terminals as possible.

standard broadcast receivers, never in all-wave sets.

Two types of low-pass filter sections are shown in figure 14. A composite arrangement comprising a section of each type is more effective than either type operating alone. A composite filter composed of one *k*-section and one shunt-derived *m*-section is shown in figure 15, and is highly recommended. The *m*-section is designed to have maximum attenuation at 1700 kHz, and for that reason C₃ should be of the close-tolerance variety.

If a fixed 150-pf mica capacitor of 5 percent tolerance is not available for C₁, a compression trimmer covering the range of 125-175 pf may be substituted and adjusted to give maximum attenuation at about 1700 kHz.

18-5 Miscellaneous Interference

Stereo Interference Stereo sound systems may receive interference from strong nearby radio transmitters, both amateur and broadcast. In most cases, the

interference is caused by stray pickup of the r-f signal by the interconnecting leads of the stereo system accompanied by audio rectification in the low-level stages of the system. The solution to this difficulty, in general, is to bypass and shield all speaker leads and bypass the power lead to the amplifier or tuner units. The power line leads may be bypassed to the chassis with a pair of .01- μ fd, 1.6-kV ceramic capacitors. Speaker leads should be shielded (with the shield grounded) and each lead bypassed to the amplifier chassis with a .001- μ fd, 600-volt ceramic capacitor. Shielded leads should also be employed between the amplifier and tuner and the phono cartridge. The framework of the turntable should be grounded to the chassis of the amplifier to reduce stray r-f pickup in the turntable wiring and equipment.

In some cases it may be necessary to install an r-f filter in the input circuit of the amplifier. A small r-f choke in series with the input lead, together with a 500-pf ceramic capacitor between leads and ground will reduce r-f pickup in the input circuit of the amplifier. In high-impedance circuits, it may be necessary to decrease the size of the capacitor to 50 pf or so to prevent loss of the higher audio frequencies.

Telephone Interference The carbon microphone of the telephone often serves as an efficient rectifier of nearby radio signals, injecting the modulation of the signal on the telephone circuit. Older (type 300) telephones merely require the installation of a .001- μ fd ceramic capacitor across the terminals of the carbon microphone. Most telephone companies supply a special capacitor for this purpose on request.

The newer 500-series telephones, however, contain an automatic-level control circuit in the base which includes a thermistor unit which is sensitive to strong r-f fields. In addition to the microphone capacitor, the 500-series unit requires the installation of a pair of 2.5-mH, 100-ma r-f chokes, one in series with each side of the line, placed within the telephone base underneath the dial mechanism. This prevents r-f pickup by the telephone line from reaching the thermistor, thus eliminating the interference.

Power-Line Interference Power-line interference may reach a radio receiver by transmission along the line or by direct radiation. Typical sources of power-line interference are spark and electrostatic discharge. Spark discharge from brush-type motors, heaters for fish aquariums, thermostats on sleeping blankets, and heating pads are prolific sources of such interference. If the interfering unit can be located, bypass capacitors on the power line directly at the unit will usually suppress the noise. The noise may often be located by using a portable radio as a direction finder, homing in on the noise source. Direct power-line noise, caused by leaky insulators or defective hardware on high-voltage transmission lines is harder to pinpoint, as the noise may be carried for a considerable distance along the line. Standing waves of noise are also apparent on power lines, leading to false noise peaks that confuse the source. Many power companies have a program of locating interfer-

ence and it is recommended that the amateur contact the local company office and register a complaint of power-line interference rather than to try and find it himself, since the cure for such troubles must be applied by the company, rather than the amateur.

Electrostatic discharge may be caused by intermittent contact between metallic objects in a strong electric field. Guy wires or hardware on power poles are a source of this form of interference. In addition, loose hardware on a nearby TV antenna, or the tower of the amateur antenna may cause this type of interference in the presence of a nearby power line. This type of interference is hard to pinpoint, but may often be found with the aid of a portable radio. In any event, suspected power-line interference originating on the power-line system should be left to the power-company interference investigator.

Station Assembly and Control

19-1 Station Layout

The amateur radio station has literally moved from the garage or home workshop into the living room during the past two decades. Gone are the black-crackle panels and the six-foot steel relay rack, and in their place are the new-design streamlined, miniaturized desk-top cabinets. Bandswitching linear amplifiers, solid-state power supplies and compact transceivers and exciters are the modern counterparts of the bulky plug-in coil class-C amplifiers, cumbersome modulators, and weighty power supplies that identified the amateur station of the late "forties."

Station location and layout, accordingly, has undergone vast changes in the past few years and it is possible to place a high-power station within a desk, bookcase, or console assembly if space is at a premium.

Ideally, the best arrangement is for a complete room in the home or apartment to be devoted to the station, affording maximum comfort for operation, yet permitting operation and work to be done with minimum interference to family life. Regardless of the size and scope of the amateur station, however, the arrangement must be one that affords maximum efficiency, power capability, and safety to the operator. The care that has gone into the equipment and accessories must be carried over into the primary

power system and control circuitry, and the control system for the rotary antenna, or antenna switching network.

Power Systems At a minimum, an amateur station will have a transceiver, or separate receiver and transmitter that will exhibit a primary power drain of about 500 watts. In addition, an electric clock, desk light, and one or two auxiliary pieces of equipment will consume another 200 watts or so. Since the usual home outlet is rated to handle only about 600 watts maximum, the transmitting equipment, unless it is of relatively low power, should be powered from a separate primary outlet. In addition, there should be an outlet available for a soldering iron and one or two additional outlets provided for powering extra pieces of equipment being worked on (figure 1).

It thus becomes obvious that six to ten outlets connected to the 117-volt a-c line should be available at the operating position. It may be practical to have this number of receptacles installed as an outlet strip along the baseboard at the time a new home is being planned or constructed. Or it might be well to install an outlet strip at the rear of the operating desk so as to have the flexibility of moving the desk from one position to another. Alternatively, the outlet strip may be wall mounted behind the desk. It is inadvisable from the standpoint

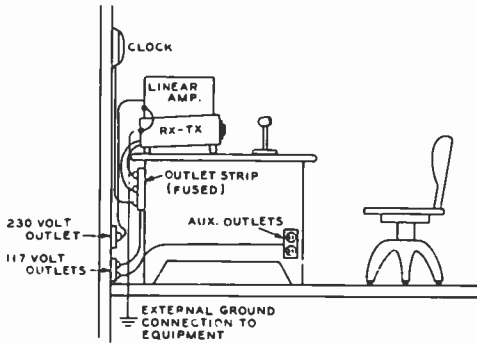

Figure 1

CONVENIENT POWER SYSTEM FOR AN AMATEUR STATION

Receiver or transceiver draws power from 117-volt a-c line through multiple-outlet strip attached to the rear of the operating desk. Additional outlets provide power for clock and other gear. A separate outlet is mounted near the front of the table for soldering iron and other temporary uses. A separate 240-volt power line is run from the main fuse box to power the linear amplifier. All equipment in the operating room is fused in series with fuses in main box. A separate 240-line is run from the main fuse box to power the linear amplifier. All equipment in the operating room is fused in series with fuses in main box. 240-volt line is run in conduit. It is recommended that the entire house be wired in conduit, if possible, to reduce r-f pickup of the primary power lines as an aid in reduction of television interference and line noise.

of safety to use a number of adapter plugs at one wall outlet to power the station equipment.

Line regulation is of importance in the amateur station installation. Poor regulation will cause the house lights to fluctuate with keying or modulation and in severe cases will cause an annoying shrinkage of the television image in a nearby receiver powered from the same line. It is good practice, therefore, to check the power capability of the house wiring before placing the full equipment load on the 117-volt primary service.

Power-Line "Standards" A confusion of power-line voltages and frequencies, as well as a multiplicity of plugs and connectors exists throughout the world. In the United States and Canada the nominal design center for consumer primary power is 117 volts, 60 Hz. Voltages between

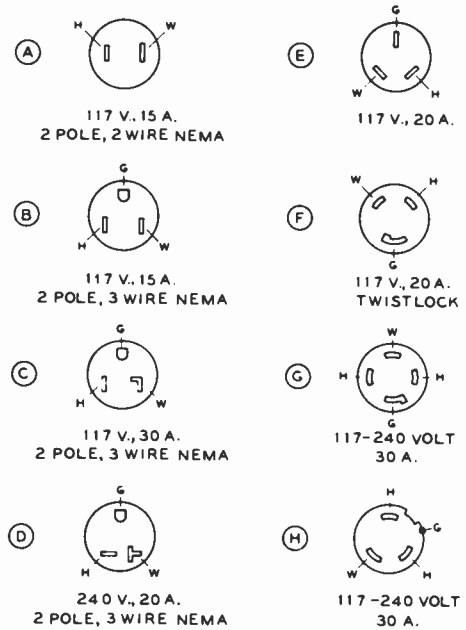

Figure 2

COMMON RECEPTACLE STANDARDS IN THE UNITED STATES

The front view of various common 117-volt and 240-volt standard receptacles is shown. 117-volt circuits have one wire (neutral) at about ground potential and the other wire (hot) above ground. The neutral wire (white W, with nickel screw terminal) is unfused while the hot wire (H, black, red, or blue with brass screw terminal) is fused. The switch should be in the hot line. The neutral is grounded at the distribution transformer and should not be grounded at any other point. Neutral is often referred to as system ground and is coded white. Equipment ground (G) is separately grounded at the electrical device and is coded green (circuits A, B, and C). 240-volt single phase receptacles are polarized so that 117-volt plugs cannot be used by error. Duplex (E) and Twistlock (F) are common industrial plugs, while the plugs of figures G and H are used with electric stoves, motors, air conditioners, etc.

110 and 125 are commonly encountered. In many overseas countries, 220 or 240 volts at 50 Hz may be found. In addition, unique combinations, such as 137 volts at 42 Hz, or 110 volts at 16 2/3 Hz may exist as a result of special circumstances. Operation of equipment on one phase of a three-phase 240-volt power system calls for a design center of 208 volts.

Aside from the primary power complexity, an endless number of plug and receptacle designs harass the experimenter. Recently, the *National Electrical Manufacturers Association* in the United States has announced standards covering general-purpose receptacles designed for the consumer wiring system, based on a design center of 117 volts, or the multiwire 240-volt, single-phase system used in many new homes.

A clear distinction is made in all specifications between *system ground* and *equipment ground*. The former, referred to as a grounded conductor, normally carries line current at ground potential. Terminals for system grounds are marked *W* and are color-coded *white*. Terminals for equipment grounds are marked *G* and are color-coded *green*. In this standard, the equipment ground carries current only during short circuit conditions.

A summary of some of the more common NEMA receptacle configurations, and other configurations still in popular use are shown in figure 2. A complete chart covering all standard NEMA plugs and receptacles may be obtained for twenty-five cents from: The Secretary, NEMA Wiring Device Section, 155 East 44th Street, New York, N.Y., 10017.

Checking an Outlet with a Heavy Load To make sure that an outlet will stand the full load of the entire transmitter, plug in an electric heater rated at about 50 percent greater wattage than the power you expect to draw from the line. If the line voltage does not drop more than 5 volts (assuming a 117-volt line) under load and the wiring does not overheat, the wiring is adequate to supply the transmitter. About 600 watts total drain is the maximum that should be drawn from a 117-volt *lighting* outlet or circuit. For greater power, a separate pair of heavy conductors should be run right from the meter box. For a 1-kw phone transmitter the total drain is so great that a 240-volt "split" system ordinarily will be required. Most of the newer homes are wired with this system, as are homes utilizing electricity for cooking and heating.

With a three-wire system, be sure there is no fuse in the neutral wire at the fuse box. A neutral fuse is not required if both "hot"

legs are fused, and, should a neutral fuse blow, there is a chance that damage to the radio transmitter will result.

If you have a high-power transmitter and do a lot of operating, it is a good idea to check on your local power rates if you are on a straight *lighting* rate. In some cities a lower rate can be obtained (but with a higher "minimum") if electrical equipment such as an electric heater drawing a specified amount of current is permanently wired in. It is not required that you use this equipment, merely that it be permanently wired into the electrical system. Naturally, however, there would be no saving unless you expect to occupy the same dwelling for a considerable length of time.

Outlet Strips The *outlet strips* which have been suggested for installation in the baseboard or for use on the rear of a desk are obtainable from the large electrical-supply houses. If such a house is not in the vicinity it is probable that a local electrical contractor can order a suitable type of strip from one of the supply-house catalogs. These strips are quite convenient in that they are available in varying lengths with provision for inserting a-c line plugs throughout their length. The a-c plugs from the various items of equipment on the operating desk then may be inserted in the outlet strip throughout its length. In many cases it will be desirable to reduce the equipment cord lengths so that they will plug neatly into the outlet strip without an excess to dangle behind the desk.

Contactors and Relays The use of power-control relays and primary switches often will add considerably to the operating convenience of the station installation. The most practical arrangement usually is to have a main a-c line switch on the operating desk to energize or cut the power to the outlet strip on the rear of the operating desk. Through the use of such a switch it is not necessary to remember to switch off a large number of separate switches on each of the items of equipment on the operating desk.

The alternative arrangement, and that which is approved by the Underwriters, is to remove the plugs from the wall both for the transmitter and for the operating-desk

outlet strip when a period of operation has been completed.

While the insertion of plugs or operation of switches usually will be found best for applying the a-c line power to the equipment, the changing over between transmit and receive can best be accomplished through the use of relays. Such a system usually involves three relays, or three groups of relays. The relays and their functions are: (1) power-control relay for the transmitter—applies the 117- or 240-volt line to the primary of the high-voltage transformer and energizes the exciter; (2) control relay for the receiver—makes the receiver inoperative by any one of a number of methods when closed, also may apply power to a keying or a modulation monitor; and (3) the antenna changeover relay—connects the antenna to the transmitter when the transmitter is energized and to the receiver when the transmitter is not operating. Several circuits illustrating the application of relays to such control arrangement are discussed in the paragraphs to follow in this chapter.

Controlling Transmitter Power Output It is necessary, in order to comply with

FCC regulations, that transmitter power output be limited to the minimum amount necessary to sustain communication. This requirement may be met in several ways. Many amateurs have a separate amplifier capable of relatively high power output for use when calling, or when interference is severe, using the exciter for local contacts, or when interference is absent. In most cases, the exciter acts as a driver for the amplifier stage when full power output is required. But the majority of the amateurs using high-power equipment also have some provision for reducing the plate voltage on the high-level stages when reduced power output is desired.

One of the most common arrangements for obtaining two levels of power output involves the use of a plate transformer having a double primary for the high-voltage power supply. The majority of the high-power plate transformers of standard manufacture have just such a dual-primary arrangement. The two primaries are designed for use with either a 117-volt or 240-volt line. When such a transformer is to be

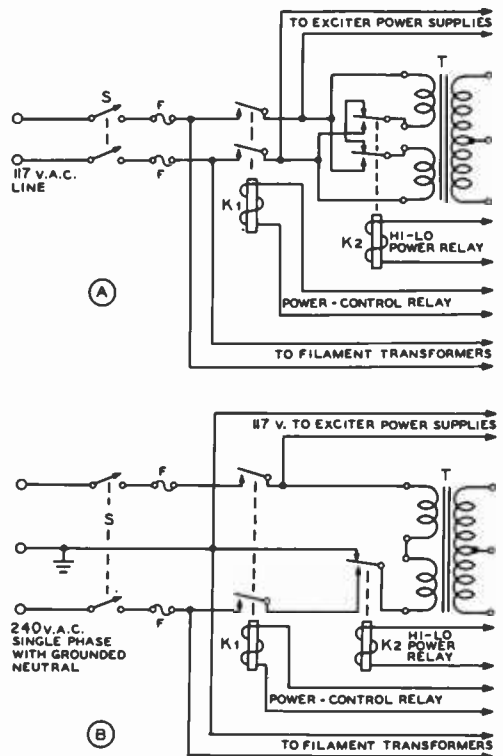

Figure 3

FULL-VOLTAGE/HALF-VOLTAGE SYSTEM OF POWER CONTROL

The circuit at A is for use with a 117-volt a-c line. Transformer T is of the standard type having two 117-volt primaries; these primaries are connected in series for half-voltage output when the power-control relay K₁ is energized but the hi-lo relay (K₂) is not operated. When both relays are energized the full output voltage is obtained. At B is a circuit for use with a standard 240-volt residence line with grounded neutral. The two relays control the output of the power supplies the same as at A.

operated from a 117-volt line, operation of both primaries in parallel will deliver full output from the plate supply. Then when the two primaries are connected in series and still operated from the 117-volt line the output voltage from the supply will be reduced approximately to one half. In the case of the normal amplifier, a reduction in plate voltage to one half will reduce the power input to the stage to one quarter.

If the transmitter is to be operated from a 240-volt line, the usual procedure is to operate the filaments from one side of the line,

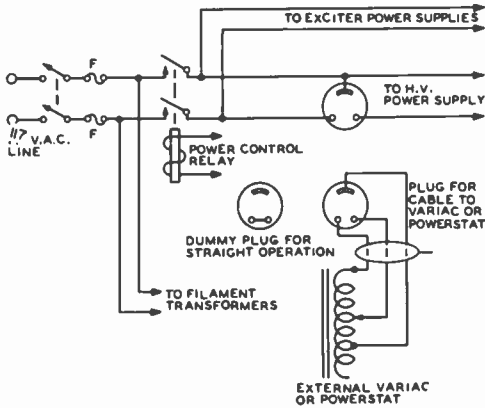

Figure 4

CIRCUIT WITH VARIABLE-RATIO AUTOTRANSFORMER

When the dummy plug is inserted into the receptacle on the equipment, closing of the power-control relay will apply full voltage to the primaries. With the cable from the Variac or Powerstat plugged into the socket the voltage output of the high-voltage power supply may be varied from zero to about 15 percent above normal.

the low-voltage power supplies from the other side, and the primaries of the high-voltage transformer across the whole line for full power output. Then when reduced power output is required, the primary of the high-voltage plate transformer is operated from one side to center tap rather than across the whole line. This procedure places 117 volts across the 240-volt winding the same as in the case discussed in the previous paragraph. Figure 3 illustrates the two standard methods of power reduction with a plate transformer having a double primary; A shows the connections for use with a 117-volt line and B shows the arrangement for a 240-volt a-c power line to the transmitter.

When tuning the transmitter, the antenna coupling network, or the antenna system itself it is desirable to be able to reduce the power input to the final stage to a relatively low value, and it is further convenient to be able to vary the power input continuously from this relatively low input up to the full power capabilities of the transmitter. The use of a variable-ratio autotransformer in the circuit from the line to the primary of

the plate transformer will allow a continuous variation in power input from zero to the full capability of the transmitter.

Variable-Ratio Autotransformers

There are several types of variable-ratio autotransformers available on the market. Of these, the most common are the *Variac* manufactured by the *General Radio Company*, and the *Powerstat* manufactured by the *Superior Electric Company*. Both these types of variable-ratio transformers are excellently constructed and are available in a wide range of power capabilities. Each is capable of controlling the line voltage from zero to about 15 percent above the nominal line voltage. Each manufacturer makes a single-phase unit capable of handling an output power of about 175 watts, one capable of about 750 to 800 watts, and a unit capable of about 1500 to 2000 watts. The maximum power-output capability of these units is available only at approximately the nominal line voltage, and must be reduced to a maximum current limitation when the output voltage is somewhat above or below the input line voltage. This, however, is not an important limitation for this type of application since the output voltage seldom will be raised above the line voltage, and when the output voltage is reduced below the line voltage the input to the transmitter is reduced accordingly.

One convenient arrangement for using a *Variac* or *Powerstat* in conjunction with the high-voltage transformer of a transmitter is illustrated in figure 4. In this circuit a heavy three-wire cable is run from a plug on the transmitter to the *Variac* or *Powerstat*. The *Variac* or *Powerstat* then is installed so that it is accessible from the operating desk so that the input power to the transmitter may be controlled during operation. If desired, the cable to the *Variac* or *Powerstat* may be unplugged from the transmitter and a dummy plug inserted in its place. With the dummy plug in place the transmitter will operate at normal plate voltage. This arrangement allows the transmitter to be wired in such a manner that an external *Variac* or *Powerstat* may be used if desired, even though the unit is not available at the time that the transmitter is constructed.

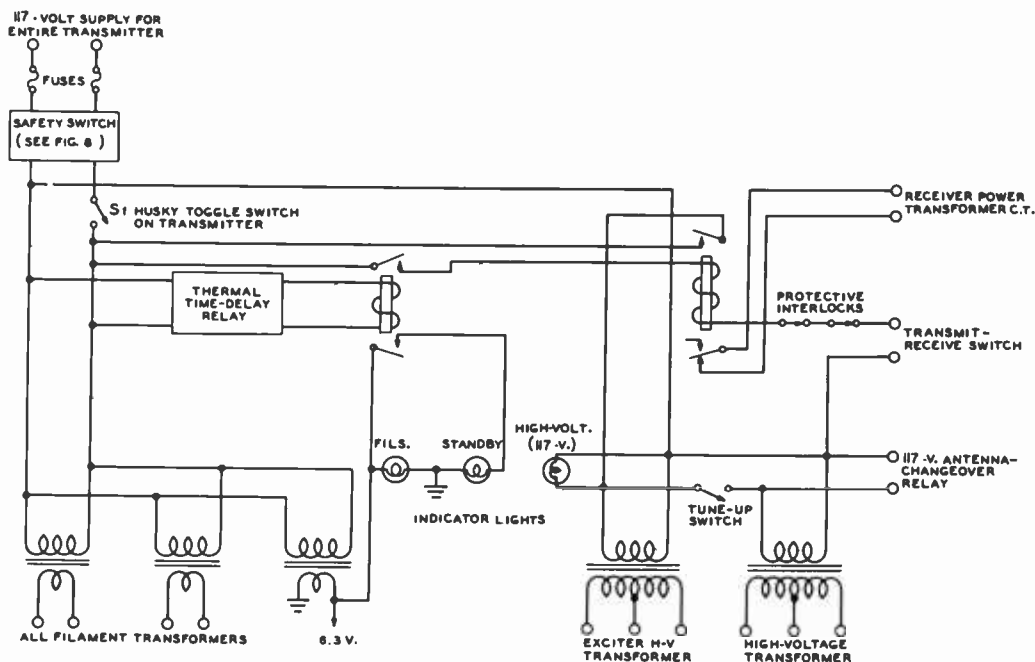

Figure 5

TRANSMITTER CONTROL CIRCUIT

Closing S₁ lights all filaments in the transmitter and starts the time-delay in its cycle. When the time-delay relay has operated, closing the transmit-receive switch at the operating position will apply plate power to the transmitter and disable the receiver. A tune-up switch has been provided so that the exciter stages may be tuned without plate voltage on the final amplifier.

Use of the Autotransformer with A-M Gear Plate voltage to the modulators may be controlled at the same time as the plate voltage to the final amplifier is varied if the modulator stage uses beam-tetrode tubes; variation in the plate voltage on such tubes used as modulators causes only a moderate change in the standing plate current.

Since the final amplifier plate voltage is being controlled simultaneously with the modulator plate voltage, the conditions of impedance match will not be seriously upset. In several high-power transmitters using this system, and using beam-tetrode modulator tubes, it is possible to vary the plate input from about 50 watts to one kilowatt without a change other than a slight increase in audio distortion at the adjustment which gives the lowest power output from the transmitter.

With triode tubes as modulators it usually will be found necessary to vary the grid bias

at the same time that the plate voltage is changed. This will allow the tubes to be operated at approximately the same relative point on their operating characteristic when the plate voltage is varied. When the modulator tubes are operated with zero bias at full plate voltage, it will usually be possible to reduce the modulator voltage along with the voltage on the modulated stage, with no apparent change in the voice quality. However, it will be necessary to reduce the audio gain at the same time that the plate voltage is reduced.

19-2 Transmitter Control Methods

Almost everyone, when getting a new transmitter on the air, has had the experience of having to throw several switches and pull or insert a few plugs when changing from receive to transmit. This is one extreme in the direction of how *not* to control a transmitter. At the other extreme we find systems

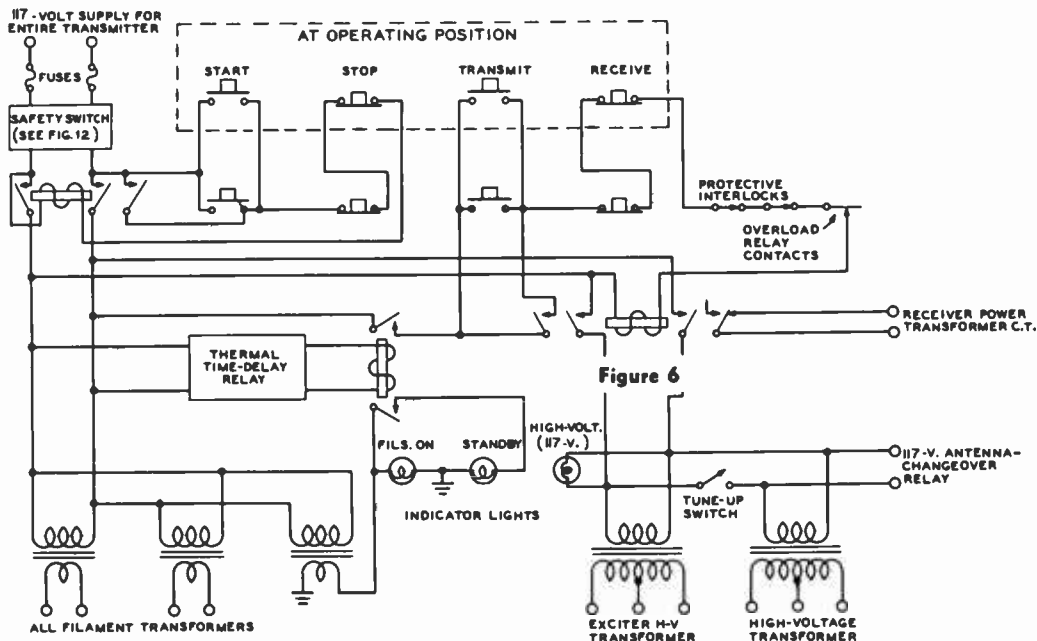

Figure 6

PUSH-BUTTON TRANSMITTER-CONTROL CIRCUIT

Pushing the **START** button either at the transmitter or at the operating position will light all filaments and start the time-delay relay in its cycle. When the cycle has been completed, a touch of the **TRANSMIT** button will put the transmitter on the air and disable the receiver. Pushing the **RECEIVE** button will disable the transmitter and restore the receiver. Pushing the **STOP** button will instantly drop the entire transmitter from the a-c line. If desired, a switch may be placed in series with the lead from the **RECEIVE** button to the protective interlocks; opening the switch will make it impossible for any person accidentally to put the transmitter on the air. Various other safety provisions, such as the protective-interlock arrangement described in the text have been incorporated. With the circuit arrangement shown for the overload-relay contacts, it is only necessary to use a simple normally closed d-c relay with a variable shunt across the coil of the relay. When the current through the coil becomes great enough to open the normally closed contacts the hold circuit on the plate-voltage relay will be broken and the plate voltage will be removed. If the overload is only momentary, such as a modulation peak or a tank flashover, merely pushing the **TRANSMIT** button will again put the transmitter on the air. This simple circuit provision eliminates the requirement for expensive overload relays of the mechanically latching type, but still gives excellent overload protection.

where it is only necessary to speak into the microphone or touch the key to change both transmitter and receiver over to the transmit condition. Most amateur stations are intermediate between the two extremes in the control provisions and use some relatively simple system for transmitter control.

When assured time delay of the proper interval and greater operating convenience are desired, a group of inexpensive a-c relays may be incorporated into the circuit to give a control circuit such as is shown in figure 5. This arrangement uses a 117-volt thermal (or motor-operated) time-delay relay and a dpdt 117-volt control relay. Note that the

protective interlocks are connected in series with the coil of the relay which applies high voltage to the transmitter. A *tune-up switch* has been included so that the transmitter may be tuned up as far as the grid circuit of the final stage is concerned before application of high voltage to the final amplifier. Provisions for operating an antenna-changeover relay and for cutting the plate voltage to the receiver when the transmitter is operating have been included.

A circuit similar to that of figure 5 but incorporating push-button control of the transmitter is shown in figure 6. The circuit features a set of **START-STOP** and **TRANS-**

MIT-RECEIVE buttons at the transmitter and a separate set at the operating position. The control push buttons operate independently so that either set may be used to control the transmitter. It is only necessary to push the START button momentarily to light the transmitter filaments and start the time-delay relay in its cycle. When the standby light comes on it is only necessary to touch the TRANSMIT button to put the transmitter on the air and disable the receiver. Touching the RECEIVE button will turn off the transmitter and restore the receiver. After a period of operation it is only necessary to touch the STOP button at either the transmitter or the operating position to shut down the transmitter. This type of control arrangement is called an electrically locking push-to-transmit control system. Such systems are frequently used in industrial electronic control.

19-3 Safety Precautions

The best way for an operator to avoid serious accidents from the high voltage supplies of a transmitter is for him to use his head, act only with deliberation, and not take unnecessary chances. However, no one is infallible, and chances of an accident are greatly lessened if certain factors are taken into consideration in the design of a transmitter, in order to protect the operator in the event of a lapse of caution. If there are too many things one must "watch out for" or keep in mind there is a good chance that sooner or later there will be a mishap; and it only takes *one*. When designing or constructing a transmitter, the following safety considerations should be given attention.

Grounds For the utmost in protection, everything of metal on the front panel of a transmitter capable of being touched by the operator should be at ground potential. This includes dial set screws, meter *zero-adjustment* screws, meter cases if of metal, meter jacks, *everything* of metal protruding through the front panel or capable of being touched or *nearly* touched by the operator. This applies whether or not the panel itself is of metal. Do not rely on the insulation of meter cases or tuning knobs for protection.

The B negative or chassis of all plate power supplies should be connected together, and to

an external ground such as a waterpipe.

Exposed Wires and Components It is not necessary to resort to rack-and-panel construction in order to provide complete enclosure of all components and wiring of the transmitter. Even with metal-chassis construction it is possible to arrange things so as to incorporate a protective shielding housing which will not interfere with ventilation yet will prevent contact with all wires and components carrying high voltage d-c or a-c, in addition to offering shielding action.

If everything on the front panel is at ground potential (with respect to external ground) and all units are effectively housed with protective covers, then there is no danger except when the operator must reach into the interior part of the transmitter, as when neutralizing, adjusting coupling, or troubleshooting. The latter procedure can be made safe by making it possible for the operator to be *absolutely certain* that all voltages have been turned off and that they cannot be turned on either by short circuit or accident. This can be done by incorporation of the following system of main primary switch and safety signal lights.

Combined Safety Signal and Switch The common method of using red pilot lights to show when a circuit is *on* is useless except from an ornamental standpoint. When the red pilot is not lit it *usually* means that the circuit is turned off, but it *can* mean that the circuit is on but the lamp is burned out or not making contact.

To enable you to touch the tank coils in your transmitter with absolute assurance that it is impossible for you to obtain a shock except from possible undischarged filter capacitors (see following topic for elimination of this hazard), it is prudent to incorporate a device similar to that of figure 7. It is placed near the point where the main 117-volt leads enter the room (preferably near the door) and in such a position as to be inaccessible to small children. Notice that this switch breaks *both* leads; switches that open just one lead do not afford complete protection, as it is sometimes possible to complete a primary circuit through a short or accidental ground. Breaking just one side

of the line may be all right for turning the transmitter on and off, but when you are going to place an arm inside the transmitter, *both* 117-volt leads should be broken.

When you are all through working your transmitter for the time being, simply throw the main switch to neutral.

When you find it necessary to work on the transmitter or change coils, throw the switch so that the green pilots light up. One should be placed on the front panel of the transmitter; others should be placed so as to be easily visible when changing coils or making adjustments requiring the operator to reach inside the transmitter.

For 100 percent protection, just obey the following rule: *never work on the transmitter or reach inside any protective cover except when the green pilots are glowing.* To avoid confusion, no other green pilots should be used on the transmitter; if you want an indicator jewel to show when the filaments are lighted, use amber instead of green.

Safety Bleeders Filter capacitors of good quality hold their charge for some time, and when the voltage is more than 100 volts it is just about as dangerous to get across an undischarged 4- μ fd filter capacitor as it is to get across a high-voltage supply that is turned on. Most power supplies incorporate bleeders to improve regulation, but as these are generally wirewound resistors, and as wirewound resistors occasionally open up without apparent cause, it is desirable to incorporate an auxiliary safety bleeder across each heavy-duty bleeder. Carbon resistors will not stand much dissipation and sometimes change in value slightly with age. However, the chance of their opening up when run well within their dissipation rating is very small.

To make *sure* that all capacitors are bled, it is best to short each one with an insulated screwdriver. However, this is sometimes awkward and always inconvenient. One can be virtually sure by connecting auxiliary carbon bleeders across all wirewound bleeders used on supplies of 1000 volts or more. For every 500 volts, connect in series a 500,000-ohm 1-watt carbon resistor. The drain will be negligible (1 ma) and each resistor will have to dissipate only 0.5 watt. Under these conditions the resistors will last indefinitely

with little chance of opening up. For a 1500-volt supply, connect three 500,000-ohm resistors in series. If the voltage exceeds an integral number of 500-volt divisions, assume it is the next higher integral value; for instance, assume 1800 volts as 2000 volts and use four resistors.

Do *not* attempt to use fewer resistors by using a higher value for the resistors; not over 500 volts should appear across any single 1-watt resistor.

In the event that the regular bleeder opens up, it will take several seconds for the auxiliary bleeder to drain the capacitors down to a safe voltage, because of the very high resistance. Therefore it is best to allow 10 or 15 seconds to elapse after turning off the plate supply before attempting to work on the transmitter.

If a 0-1 d-c milliammeter is at hand, it may be connected in series with the auxiliary bleeder to act as a high-voltage voltmeter.

"Hot" Adjustments Some amateurs contend that it is almost impossible to make certain adjustments, such as coupling and neutralizing, unless the transmitter is running. The best thing to do is to make all neutralizing and coupling devices adjustable from the front panel by means of flexible control shafts which are broken with insulated couplings to permit grounding of the panel bearing.

If your particular transmitter layout is such that this is impractical and you refuse to throw the main switch to make an adjustment—throw the main switch—take a reading—throw the main switch—make an adjustment—and so on, then protect yourself by making use of long adjustment rods made from 1/2-inch dowel sticks which have been wiped with oil when perfectly free from moisture.

Protective Interlocks With the increasing tendency toward construction of transmitters in desk cabinets a transmitter becomes a particularly lethal device unless adequate safety provisions have been incorporated. Even with a combined safety signal and switch as shown in figure 7 it is still conceivable that some person unfamiliar with the transmitter could come in contact with high voltage. It is therefore

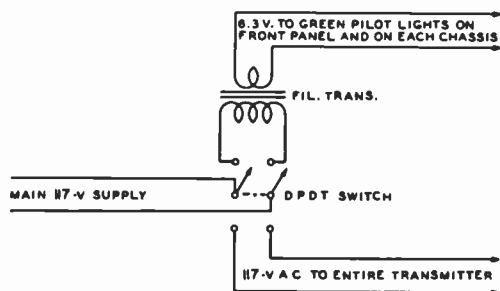

Figure 7

COMBINED MAIN SWITCH AND SAFETY SIGNAL

When shutting down the transmitter, throw the main switch to neutral. If work is to be done on the transmitter, throw the switch all the way to "pilot," thus turning on the green pilot lights on the panel and on each chassis, and ensuring that no voltage can exist on the primary of any transformer, even by virtue of a short or accidental ground.

recommended that the transmitter, whenever possible, be built into a complete metal housing or cabinet and that all doors or access covers be provided with protective interlocks (all interlocks must be connected in series) to remove the high voltage whenever these doors or covers are opened. The term "high voltage" should mean any voltage above approximately 50 volts, although it is still possible to obtain a serious burn from a 50-volt circuit under certain circumstances. The 50-volt limit usually will mean that grid-bias supplies as well as high-voltage packs should have their primary circuits opened when any interlock is opened.

Relay Sequence It is important that the antenna changeover relay be activated before r-f power flows through the relay contacts. Certain VOX or key-operated sequences do not provide this protection. As a result, the contacts of the antenna relay may be damaged from making and breaking the r-f current, or eventual damage may occur to the transmitting equipment because of repeated operation without r-f load during the periods of time necessary for the antenna relay to close. The proper relay sequence can be achieved by actuating the antenna relay by the control

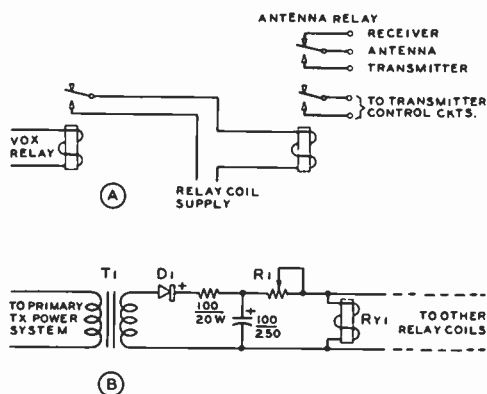

Figure 8

ANTENNA-RELAY CONTROL SYSTEM

A—Antenna relay should be actuated before r-f power flows through contacts. Extra set of contacts are used to control transmitter circuits after antenna relay closes. **B**—A-c relays may be operated from simple d-c power supply to reduce hum and chatter. Transformer T_1 may be a 1:1 isolation transformer of 50 watts capacity, with D_1 a 1 ampere, 600 volt p.i.v. diode. Series resistor R_1 is adjusted to provide proper relay action and may be of the order of 500 to 5000 ohms, 50 watts. Additional relay coils may be placed in parallel across coil R_{y1} . Relay may be energized by applying primary power (with due regard to time-lag in filter system) or by completing secondary circuit between resistor R_1 and relay coil.

system, then, in turn, actuating the transmitter by a separate set of control contacts on the antenna relay, as shown in figure 8A. In this manner, the antenna relay must be closed before r-f is applied to the contacts.

D-C Relay Operation Relays designed to operate from an a-c source are often troublesome sources of audible hum and chatter. Cleaning the relay striker and pole pieces will alleviate this annoyance somewhat, but operation of the relay from a d-c source will eliminate this difficulty. A-c relays may be operated without damage from a d-c source capable of supplying a d-c voltage equal to about 70 percent of the a-c design voltage. Thus an 85-volt d-c supply will be proper to operate 117-volt a-c relays. A suitable supply for such service is shown in figure 8B.

19-4 Transmitter Keying

The carrier from a c-w telegraph transmitter must be broken into dots and dashes for the transmission of code characters. The carrier signal is of constant amplitude while the key is closed, and is entirely removed when the key is open. When code characters are being transmitted, the carrier may be considered as being modulated by the keying. If the change from the no-output condition to full-output, or vice versa, occurs too rapidly, the rectangular pulses which form the keying characters contain high-frequency components which take up a wide frequency band as sidebands and are heard as clicks.

To be capable of transmitting code characters and at the same time not splitting the eardrums of neighboring amateurs, the c-w transmitter *must* meet two important specifications.

1. It must have no parasitic oscillations either in the stage being keyed or in any succeeding stage.
2. It must have some device in the keying circuit capable of shaping the leading and trailing edge of the waveform.

Both these specifications must be met before the transmitter is capable of c-w operation. Merely turning a transmitter on and off by the haphazard insertion of a telegraph key in some power lead is an invitation to trouble.

The two general methods of keying a transmitter are those which control the excitation to the keyed amplifier, and those which control the plate or screen voltage applied to the keyed amplifier.

Key-Click Elimination Key-click elimination is accomplished by preventing a too-rapid make and break of power to the antenna circuit, thus rounding off the keying characters so as to limit the sidebands to a value which does not cause interference to adjacent channels. Too much lag will prevent fast keying, but fortunately key clicks can be practically eliminated without limiting the speed of manual (hand) keying. Some circuits which eliminate key clicks introduce too much time lag and thereby add *tails* to the dots. These tails may cause the signals to be difficult to copy at high speeds.

Location of Keyed Stage Considerable thought should be given as to which stage in a transmitter is the proper one to key. If the transmitter is keyed in a stage close to the oscillator, the change in r-f loading of the oscillator will cause the oscillator to shift frequency with keying. This will cause the signal to have a distinct chirp. The chirp will be multiplied as many times as the frequency of the oscillator is multiplied. A chirpy oscillator that would be passable on 80 meters would be unusable on 28-MHz c.w.

Keying the oscillator itself is an excellent way to run into keying difficulties. If no key-click filter is used in the keying circuit, the transmitter will have bad key clicks. If a key-click filter is used, the slow rise and decay of oscillator voltage induced by the filter action will cause a keying chirp. This action is true of all oscillators, whether electron coupled or crystal controlled.

The more amplifier or doubler stages that follow the keyed stage, the more difficult it is to hold control of the shape of the keyed waveform. A heavily excited doubler stage or class-C stage acts as a peak clipper, tending to square up a rounded keying impulse, and the cumulative effect of several such stages cascaded is sufficient to square up the keyed waveform to the point where bad clicks are reimposed on a clean signal.

A good rule of thumb is to never key back farther than one stage removed from the final amplifier stage, and never key closer than one stage removed from the frequency-controlling oscillator of the transmitter. Thus there will always be one isolating stage between the keyed stage and the oscillator, and one isolating stage between the keyed stage and the antenna. At this point the waveform of the keyed signal may be most easily controlled.

Keyer Circuit Requirements In the first place it may be established that the majority of new design transmitters, and many of those of older design as well, use a medium-power beam tetrode tube or a zero-bias triode either as the output stage or as the driver for the output stage of a high power transmitter.

Second, it may be established that it is undesirable to key further down in the trans-

mitter chain than the stage just ahead of the final amplifier. If a low-level stage, which is followed by a series of amplifiers, is keyed, serious transients may be generated in the output of the transmitter even though the keyed stage is being turned on and off very smoothly. This condition arises as a result of *pulse sharpening*, which has been discussed previously.

Third, the output from the stage should be completely cut off when the key is up, and the time constant of the rise and decay of the keying wave should be easily controllable.

Fourth, it should be possible to make the rise period and the decay period of the keying wave approximately equal. This type of keying envelope is the only one tolerable for commercial work, and is equally desirable for obtaining clean-cut and easily readable signals in amateur work.

Last, for the sake of simplicity and safety, it should be possible to ground the frame of the key, and yet the circuit should be such that placing the fingers across the key will not result in an electrical shock. In other words, the keying circuit should be inherently safe.

All these requirements have been met in the keying circuits to be described.

19-5 Cathode Keying

The lead from the cathode or center-tap connection of the filament of an r-f amplifier can be opened and closed for a keying circuit. Such a keying system opens the plate voltage circuit and at the same time opens the grid bias return lead. For this reason, the grid circuit is blocked at the same time the plate circuit is opened. This helps to reduce the backwave that might otherwise leak through the keyed stage.

The simplest cathode keying circuit is illustrated in figure 9, where a key-click filter is employed, and a hand key is used to break the circuit. This simple keying circuit is not recommended for general use, as considerable voltage may be developed across the key when it is open.

An electronic switch can take the place of the hand key. This will remove the danger of shock. At the same time, the opening

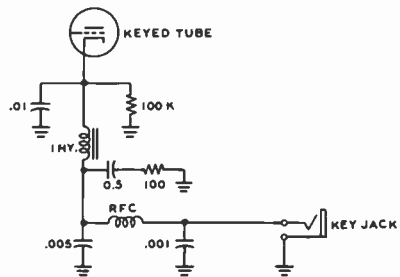

Figure 9

CENTER-TAP KEYING WITH KEY CLICK FILTER

The constants shown are suggested as preliminary values and may be changed to permit optimum amplifier keying under different operating conditions. Inductance of iron-core choke and series capacitor value are changed to alter keying characteristic. R-f choke and associated capacitors reduce transients caused by sparking at key contacts.

and closing characteristics of the electronic switch may easily be altered to suit the particular need at hand. Such an electronic switch is called a *vacuum-tube keyer*. Low internal resistance triode tubes such as the 2A3 or 6AS7 are used in the keyer. These tubes act as a very high resistance when sufficient blocking bias is applied to them, and as a very low resistance when the bias is removed. The desired amount of lag or *cushioning effect* can be obtained by employing suitable resistance and capacitance values in the grid of the keyer tube(s). Because very little spark is produced at the key, due to the small amount of power in the key circuit, sparking clicks are easily suppressed.

One type 6AS7 tube (both sections) should be used for every 250 ma of plate current. Type 2A3 tubes may also be used; allow one 2A3 tube for every 80 ma of plate current.

Because of the series resistance of the keyer tubes, the plate voltage at the keyed tube will be from 30 to 60 volts less than the power supply voltage. This voltage appears as cathode bias on the keyed tube, assuming the bias return is made to ground, and should be taken into consideration when providing bias.

Some typical cathode circuit vacuum-tube keying units are shown in figure 10.

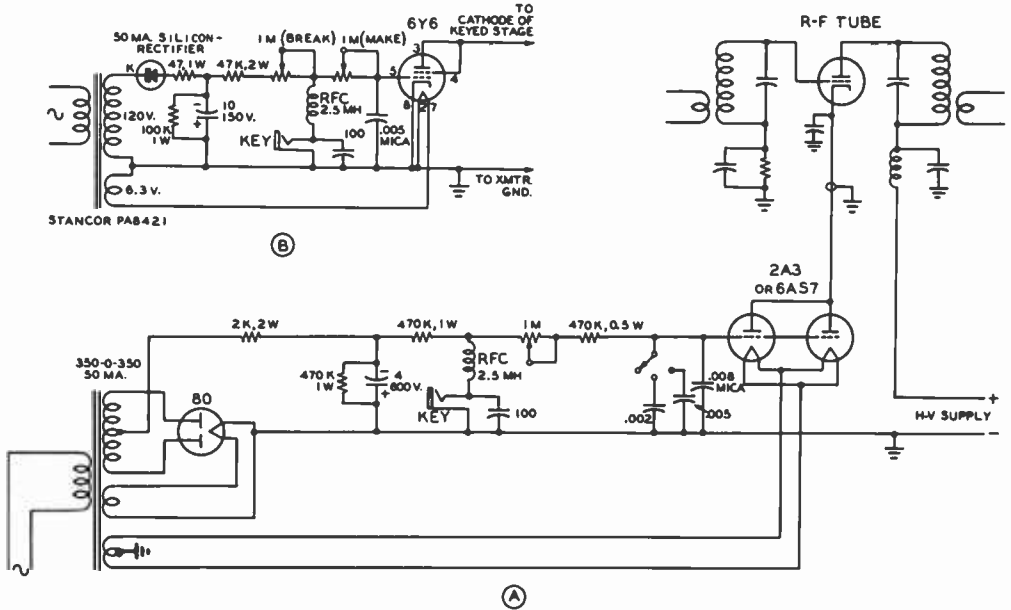

Figure 10

VACUUM-TUBE KEYERS FOR CENTER-TAP KEYING CIRCUIT

The type-A keyer is suitable for keying stages running up to 1250 volts on the plate. Two 2A3's or a 6A57 tube can safely key 160 milliamperes of cathode current. The simple 6Y6 keyer in figure B is for keying stages running up to 650 volts on the plate. A single 6Y6 can key 80 milliamperes. Two in parallel may be used for plate currents under 160 ma. If softer keying is desired, the .005 μ fd mica capacitor should be increased to .01 μ fd.

19-6 Grid-Circuit Keying

Grid-circuit, or *blocked-grid keying* is another effective method of keying a c-w transmitter. A basic blocked-grid keying circuit is shown in figure 11. The time constant of the keying is determined by the RC circuit, which also forms part of the bias circuit of the tube. When the key is closed, operating bias is developed by the flow of grid current through R_1 . When the key is open, sufficient fixed bias is applied to the tube to block it, preventing the stage from functioning. If an un-neutralized tetrode is keyed by this method, there is the possibility of a considerable backwave caused by r-f leakage through the grid-plate capacitance of the tube.

Certain high- μ triode tubes, such as the 811-A and the 3-400Z, automatically block themselves when the grid-return circuit is opened. It is merely necessary to insert a key

and associated key-click filter in the grid-return lead of these tubes. No blocking bias supply is needed. This circuit is shown in figure 12.

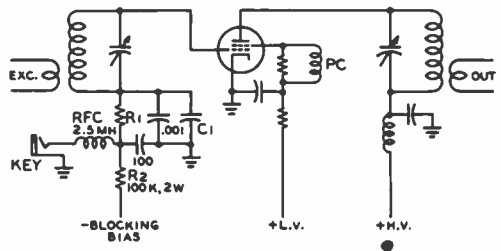

Figure 11

SIMPLE BLOCKED-GRID KEYING SYSTEM

The blocking bias must be sufficient to cut off plate current to the amplifier stage in the presence of the excitation voltage. R_1 and C_1 should be adjusted for correct keying waveform.

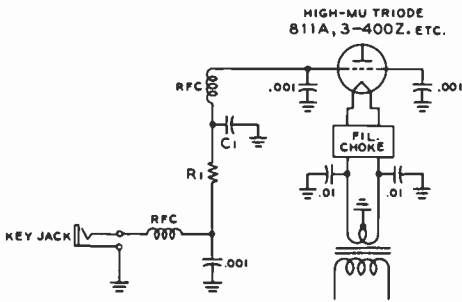

Figure 12

SELF-BLOCKING KEYING SYSTEM FOR HIGH-μ (ZERO BIAS) TRIODE

High-μ triodes such as the 811A, 572B (T-160L), 3-400Z, 3-500Z, etc. may be keyed by opening the d-c grid return circuit. Components R₁ and C₁ are adjusted for correct keying waveform. This circuit is not suited for keying a linear amplifier stage as the voltage drop across resistor R₁ provides additional grid bias to the amplifier tube.

A more elaborate blocked-grid keying system using a 6C4 and VR-150 is shown in figure 13. Two stages are keyed, preventing any backwave emission. The first keyed stage may be the oscillator, or a low-powered buffer. The last keyed stage may be the

driver stage to the power amplifier, or the amplifier itself. Since the circuit is so proportioned that the lower-powered stage comes on *first* and goes off *last*, any keying chirp in the oscillator is not emitted on the air. Keying lag is applied to the high-powered keyed stage only.

19-7 Screen-Grid Keying

The screen circuit of a tetrode tube may be keyed for c-w operation. Unfortunately, when the screen grid of a tetrode tube is brought to zero potential, the tube still delivers considerable output. Thus it is necessary to place a negative blocking voltage on the screen grid to reduce the backwave through the tube. A suitable keyer circuit which will achieve this is shown in figure 14A. A 6L6 is used as a combined clamper tube and keying tube. When the key is closed, the 6L6 tube has blocking bias applied to its control grid. This bias is obtained from the rectified grid bias of the keyed tube. Screen voltage is applied to the keyed stage through a screen dropping resistor and a VR-105 regulator tube. When the key is open, the 6L6 is no longer cutoff, and conducts heavily. The voltage drop across the dropping resistor caused by the heavy plate current of the 6L6 lowers the voltage on the VR-105 tube until it is extinguished, removing the screen voltage from the tetrode r-f tube. At the same time, rectified grid bias is applied to the screen of the tetrode through the 1 megohm resistor between screen and key. This voltage effectively cuts off the screen of the tetrode until the key is closed again. The RC circuit in the grid of the 6L6 tube determines the keying characteristic of the tetrode tube.

A simple keying relay for screen-grid keying is shown in figure 14B.

A more elaborate screen-grid keyer is shown in figure 15. This keyer is designed to block-grid-key the oscillator or a low-powered buffer stage, and to screen-key a medium-powered tetrode tube such as an 807, 2E26 or 6146. A 6BL7 is used as the screen keyer, and a 12AU7 is used as a cathode follower and grid-block keyer. As in the figure 13 circuit, this keyer turns on the exciter a moment before the tetrode

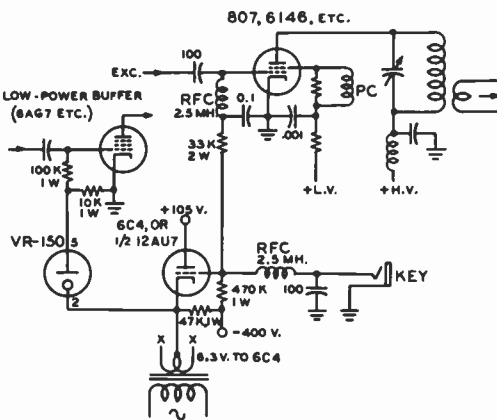

Figure 13

TWO-STAGE BLOCKED-GRID KEYER

A separate filament transformer must be used for the tube, as its filament is at a potential of -400 volts.

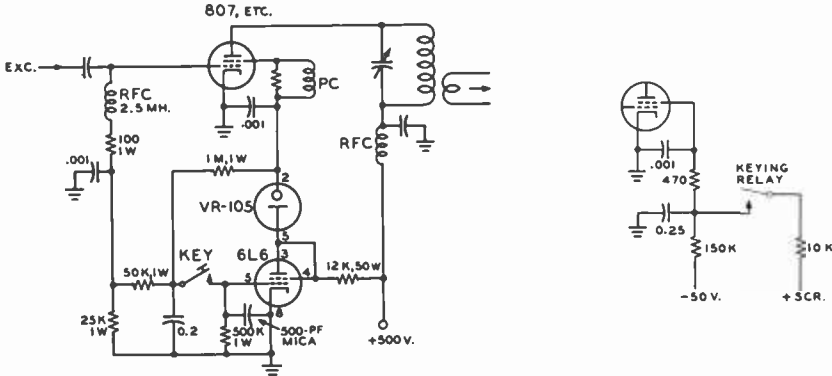

Figure 14

SCREEN-GRID KEYER CIRCUITS FOR TETRODE AND PENTODE TUBES

A—A 6L6 acts as a clamper and keyer tube. When key is open, 6L6 conducts and voltage drop across screen resistor extinguishes the voltage regulator tube, removing screen voltage from the tetrode tube. Bias is applied to screen to completely cut off the tetrode. B—Simple version of circuit A employs screen keying relay. When relay is open, negative bias voltage applied through 150K resistor effectively blocks tetrode-tube screen circuit.

stage is turned on. The tetrode stage goes off on instant before the exciter does. Thus any keying chirp of the oscillator is effectively removed from the keyed signal.

By listening in the receiver one can hear the exciter stop operating a fraction of a second after the tetrode stage goes off. In fact, during rapid keying, the exciter may be

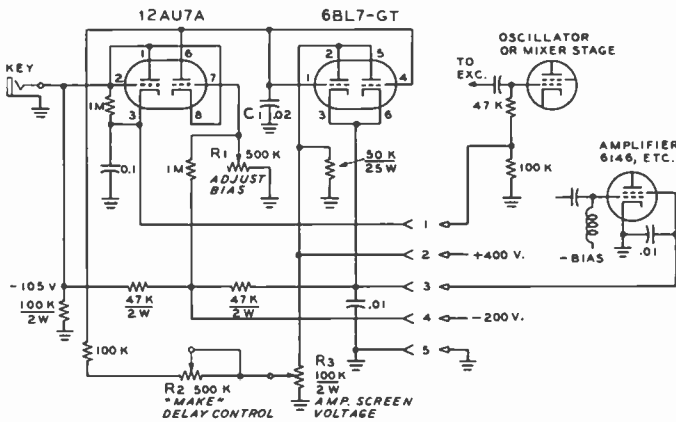

Figure 15

DIFFERENTIAL KEYING SYSTEM FOR SCREEN CIRCUIT

This keyer contains a 6BL7 series screen-voltage keyer tube and utilizes one-half of a 12AU7 as a control triode for the keyer tube. The second section of the 12AU7 is diode-connected to apply blocking bias to the 6BL7. With open key, pin 7 of the 12AU7 is adjusted to about -85 volts by means of potentiometer R₁, using vtvm. The 12AU7 and 6BL7 are now plugged in their sockets and, with the key still open, -105 to -110 volts should be observed at cathode pin 3 of the 12AU7. The screen voltage to the keyed amplifier stage (6146, etc.) should be about -50 volts. With the key closed, screen control potentiometer R₁ should be set to the proper screen voltage. Sharpness of keying on wave front is adjusted by the setting of potentiometer R₂. "Softness" of keying may be increased by raising value of capacitor C. The 6BL7 tube should be run from separate 6.3-volt filament supply with the filament transformer center tap connected to amplifier screen voltage lead to keep heater-cathode voltage of 6BL7 within its rating.

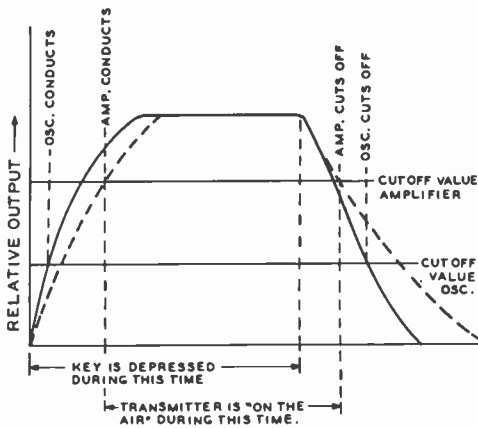

Figure 16
TIME SEQUENCE OF A DIFFERENTIAL KEYS

heard as a steady signal in the receiver, as it has appreciable time lag in the keying circuit. The clipping effect of following stages has a definite hardening effect on this, however.

19-8 Differential Keying Circuits

Excellent waveshaping may be obtained by a *differential keying system* whereby the master oscillator of the transmitter is turned on a moment before the rest of the stages are energized, and remains on a moment longer than the other stages. The chirp, or frequency shift, associated with abrupt switching of the oscillator is thus removed from the emitted signal. In addition, the

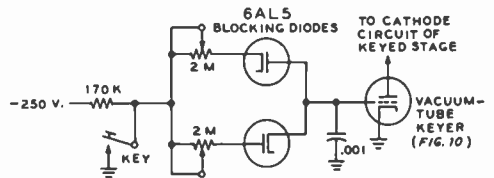

Figure 17

BLOCKING DIODES EMPLOYED TO VARY TIME CONSTANT OF "MAKE" AND "BREAK" CHARACTERISTICS OF VACUUM-TUBE KEYS

differential keyer can apply waveshaping to the amplifier section of the transmitter, eliminating the click caused by rapid keying of the latter stages.

The ideal keying system would perform as illustrated in figure 16. When the key is closed, the oscillator reaches maximum output almost instantaneously. The following stages reach maximum output in a fashion determined by the waveshaping circuits of the keyer. When the key is released, the output of the amplifier stages starts to decay in a predetermined manner, followed shortly thereafter by cessation of the oscillator. The over-all result of these actions is to provide relatively soft "make" and "break" to the keyed signal, meanwhile preventing oscillator frequency shift during the keying sequence.

The rates of charge and decay in a typical RC keying circuit may be varied independently of each other by the blocking-diode system of figure 17. Each diode permits the charging current of the timing capacitor to flow through only one of the two variable

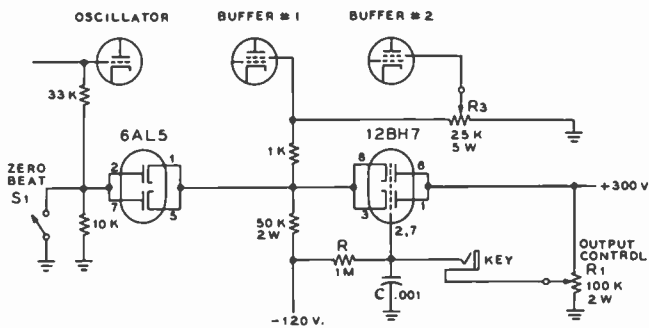

Figure 18

DIFFERENTIAL KEYS SYSTEM WITH OSCILLATOR-SWITCHING DIODE

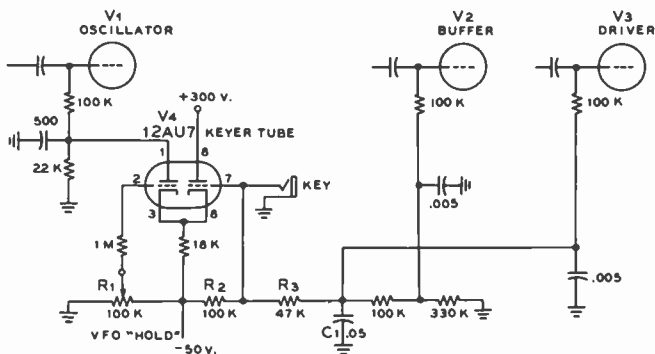

Figure 19

DIFFERENTIAL KEYER USING A 12AU7 DOUBLE TRIODE

potentiometers, thus permitting independent adjustment of the "make" and "break" characteristics of the keying system.

A practical differential keying system making use of this differential technique is shown in figure 18. A 6AL5 switch tube turns the oscillator on before the keying action starts, and holds it on until after the keying sequence is completed. Time constant of the keying cycle is determined by values of C and R. When the key is open, a cutoff bias of about -110 volts is applied to the screen-grid circuits of the keyed stages. When the key is closed, the screen-grid voltage rises to the normal value at a rate determined by the time constant (RC). On opening the key again, the screen voltage returns to cutoff value at the predetermined rate.

The potentiometer (R₁) serves as an output control, varying the minimum internal resistance of the 12BH7 keyer tube, and is a useful device to limit power input during tuneup periods. Excitation to the final amplifier stage may be controlled by the screen potentiometer (R₃) in the second buffer stage. An external bias source of approximately -120 volts at 10 ma is required for operation of the keyer, in addition to the 300-volt screen supply.

Blocking voltage may be removed from the oscillator for zeroing purposes by closing switch S₁, rendering the diode switch inoperative.

A second popular keying system is shown in figure 19. Grid-block keying is used

on tubes V₂ and V₃. A waveshaping filter consisting of R₂, R₃, and C₁ is used in the keying control circuit of V₂ and V₃. To avoid chirp when the oscillator (V₁) is keyed, the keyer tube V₄ allows the oscillator to start quickly—before V₂ and V₃ start conducting—and then continue operating until after V₂ and V₃ have stopped conducting. Potentiometer R₁ adjusts the "hold" time for vfo operation after the key is opened. This may be adjusted to cut off the vfo between marks of keyed characters, thus allowing rapid break-in operation.

Transmitter Keying The c-w transmitter keying comprises more than simply turning the carrier on and off by means of a telegraph key. The previous circuits are designed to provide clean crisp keying, when properly adjusted, without click or snap on the keyed waveform. The optimum keying characteristic is a highly subjective thing and "on-the-air" checks are questionable, since many amateurs hesitate to be truly critical of another amateur's signal unless it is causing objectionable interference.

Observation of the r-f waveform of the keyed signal on an oscilloscope can quickly show the operator the characteristic of his signal and comparison of the 'scope image with the signal heard in a local monitor will quickly provide good knowledge of the keyed signal. A properly keyed signal will have minimum thump on the make, and no perceptible click on the break. Illustration

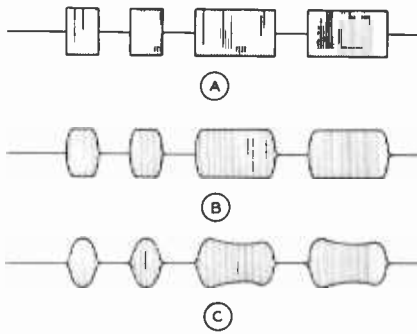

Figure 20

C-W KEYING CHARACTERISTICS

A—Abrupt rise and decay time of dot character leads to severe key clicks on make and break. B—Simple keying filter rounds dot character reducing transition time between key-open and key-closed condition. C—Poor power-supply regulation can distort keying waveform and add “yoop” to signal.

A (figure 20) shows a keyed signal having no control of make or break. The abrupt rise and decay of the waveform generates severe clicks and thumps that would be extremely objectionable on the air. Suitable filter circuits increase the rise and decay time of the signal (B), reducing the abrupt transition times to conservative values. Poor power-supply regulation can alter an otherwise perfect keyed waveform (C). Insufficient filter capacitance permits the power

in the keyed wave to drop during long dashes, adding an unusual “yoop” to the signal. Other undesirable effects such as excess ripple on the waveform may be easily observed with the use of an oscilloscope.

19-9 VOX Circuitry

A form of VOX (*voice-operated transmission*) is often employed in SSB operation. The VOX circuitry makes use of a transmitter control relay that is actuated by the operator’s voice and is held open by an *anti-vox* circuit actuated by the audio system of the station receiver. Voice-controlled break-in operation is thus made possible without annoying feedback from the receiver speaker. A representative VOX system is illustrated in figure 21. The VOX signal voltage is taken from the speech amplifier of the SSB transmitter and adjusted to the proper amplitude by means of *VOX-gain* potentiometer. The signal is rectified by diode V_2A and the positive voice impulses are applied to the grid of the VOX relay tube (V_3A) which is normally biased to cutoff. An RC network in the VOX rectifier circuit permits rapid relay action yet delays the opening of the relay so that VOX action is sustained during syllables and between words. Delay periods of up to 0.5 second are common.

The antivox signal voltage is derived from the speaker circuit of the receiver, adjusted to the proper amplitude by the *antivox-gain* potentiometer and rectified by diode V_2B to provide a negative voice impulse which biases the vox diode (V_2A) to a nonconducting state. The relay is held in a cut-off position until a positive override signal from the VOX circuit defeats the antivox signal taken from the station receiver. The relay tube may also be actuated by the *manual* switch which drops the bias level, causing the tube to draw a heavy plate current and trip the VOX relay.

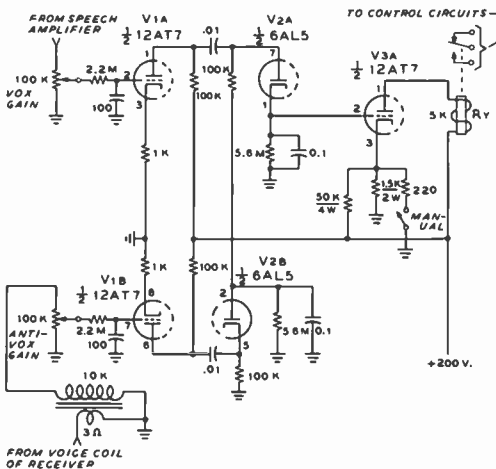

Figure 21

A REPRESENTATIVE VOX CIRCUIT

VOX Control for a Transceiver A practical and reliable VOX circuit for a transceiver is shown in figure 22. A primary consideration in transceiver VOX design is that the VOX circuit must provide a controlled delay to prevent the

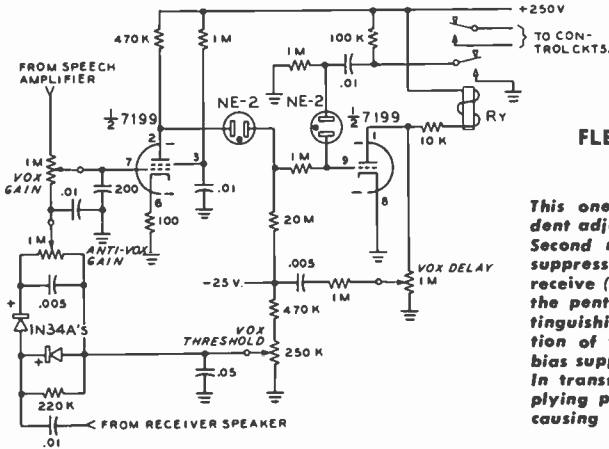

Figure 22
FLEXIBLE VOX CIRCUIT FOR SSB TRANSCEIVER

This one-tube VOX circuit provides independent adjustment of gain, threshold, and delay. Second neon lamp is connected as transient suppressor across extra relay contacts. In receive (no input signal from speech amplifier), the pentode section of the 7199 conducts, extinguishing the neon lamp and the triode section of the 7199 is cut off by the -25 volt bias supply. The VOX relay thus remains open. In transmit, the input signal is amplified applying positive bias to the VOX control tube, causing relay contacts to close. VOX delay as long as 3 seconds is available.

VOX relay from returning the transceiver to the receive condition between words or short pauses in the operator's speech. The delay should be adjustable, yet the VOX must permit switching so that the first portion of the syllable of the first words is not lost during the switching sequence.

An antivoice circuit is incorporated to reduce VOX sensitivity to signals received from the receiver speaker and a VOX threshold adjustment provides complete independence of sensitivity and delay-time adjustment.

VOX excitation is taken from the speech amplifier and amplified through the pentode section of a 7199. With the first neon lamp extinguished, the triode section of the 7199 is cut off, leaving the VOX relay (Ry)

open. With a voice signal, the neon lamp ignites, causing the triode section to conduct and energize the VOX relay. A portion of the VOX signal is rectified by two diodes for the threshold voltage and, in addition, the antivoice is fed in at this point, providing an auxiliary control voltage for the pentode section of the 7199. VOX delay may be varied over the range of 0.2 to 3 seconds.

To reduce switching transients to a minimum, a second neon lamp is placed in an RC circuit in the control-grid leg of the 7199. When the VOX relay is actuated, the .01- μ fd capacitor is discharged, and the resulting negative pulse holds the triode section of the 7199 in a cutoff state for a short period of time until the neon lamp is extinguished. A separate set of contacts

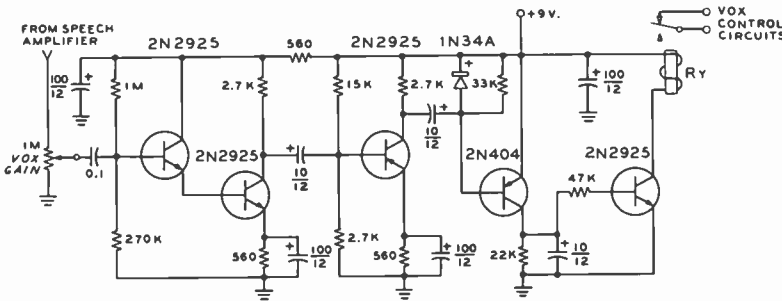

Figure 23

TRANSISTORIZED VOX

Self-contained VOX circuit may be added to existing equipment. Relay has pull-in current of about 7 ma. (Sigma 11F-1000G-SIL). Unenergized relay current is 3 ma, and actual pull-in current is 12 ma.

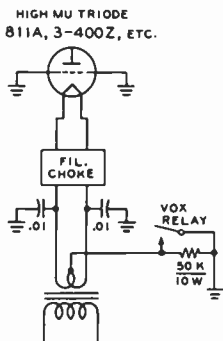

Figure 24

VOX BIAS CONTROL

Cutoff bias for grounded-grid triode may be obtained from cathode bias resistor. Action of VOX relay shorts out resistor, restoring amplifier to normal operating conditions.

on the VOX relay are used for various control circuits in the transceiver.

A Transistor The transistor VOX circuit shown in figure 23 may be added to existing SSB equipment, or may be included in new-design equipment to provide inexpensive and compact VOX control. The unit is powered from a 9-volt transistor-radio battery, or power may be obtained from a well-filtered tap point in the station equipment.

The input impedance of the first emitter-follower stage is of sufficiently high impedance to work directly from a crystal micro-

phone or from the grid circuit of the first or second speech-amplifier stage in the station equipment. Two stages of high-gain RC amplifier follow the direct coupled input stage and the enhanced voice signal is rectified and clamped in a 1N34-2N404 combination, the output of which drives a 2N2925 relay-control transistor. Time delay is determined by a capacitor in the emitter circuit of the 2N404. Relay dropout is determined largely by the travel time of the relay armature.

VOX Bias Control It is desirable to completely disable a high-power linear amplifier during reception for two

reasons: first, the amplifier consumes standby power unless it is biased to cutoff and, second, many amplifiers will generate "white noise" when in a normal standby condition. The white noise, or diode noise, may show up in the receiver as a loud hiss interfering with all but the loudest signals.

The circuit of figure 24 provides an automatic cutoff-bias system for a VOX-controlled amplifier stage. The resting plate current of the amplifier is passed through a 50K resistor in the filament return circuit, creating a voltage drop that is applied as cutoff bias to the tube(s). The filament circuit is raised to a positive voltage with respect to the grid, thus leaving the grid in a negative, cutoff condition. On activation of the VOX relay, a separate set of contacts short out the bias resistor, restoring the amplifier stage to normal operating condition.

Radiation, Propagation, and Transmission Lines

Radio waves are electromagnetic waves similar in nature to, but much lower in frequency than, light waves or heat waves. Such waves represent electric energy traveling through space. Radio waves travel in free space with the velocity of light and can be reflected and refracted much the same as light waves.

20-1 Radiation from an Antenna

Alternating current passing through a conductor creates an alternating electromagnetic field around that conductor. Energy is alternately stored in the field, and then returned to the conductor. As the frequency is raised, more and more of the energy does not return to the conductor, but instead is radiated off into space in the form of electromagnetic waves, called radio waves. Radiation from a wire, or wires, is materially increased whenever there is a sudden *change* in the *electrical constants* of the line. These sudden changes produce reflection, which places *standing waves* on the line.

When a wire in space is fed radio-frequency energy having a wavelength of approximately 2.1 times the length of the wire in meters, the wire *resonates* as a *half-wave dipole* antenna at that wavelength or frequency. The greatest possible change in the electrical constants of a line is that which

occurs at the open end of a wire. Therefore, a dipole has a great mismatch at each end, producing a high degree of reflection. We say that the ends of a dipole are terminated in an *infinite impedance*.

A returning wave which has been reflected meets the next incident wave, and the voltage and current at any point along the antenna are the vector sum of the two waves. At the ends of the dipole, the voltages add, while the currents of the two waves cancel, thus producing *high voltage* and *low current* at the *ends* of the dipole or half-wave section of wire. In the same manner, it is found that the currents add while the voltages cancel at the center of the dipole. Thus, at the *center* there is *high current* but *low voltage*.

Inspection of figure 1 will show that the current in a dipole decreases sinusoidally toward either end, while the voltage similarly increases. The voltages at the two ends of the antenna are 180° out of phase, which means that the polarities are opposite, one being plus while the other is minus at any instant. A curve representing either the voltage or current on a dipole represents a *standing wave* on the wire.

Radiation From Sources Other Than Antennas Radiation can and does take place from sources other than antennas. Undesired radiation can take place from open-wire transmission lines, both from sin-

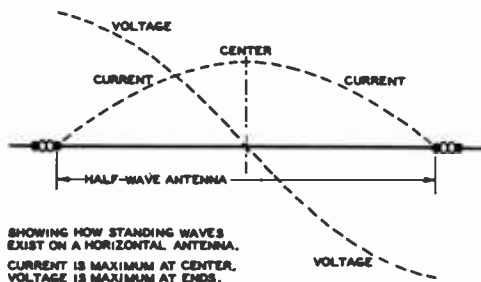

Figure 1

STANDING WAVES ON A RESONANT ANTENNA

gle-wire lines and from lines comprised of more than one wire. In addition, radiation can be made to take place in a very efficient manner from electromagnetic horns, from plastic lenses or from electromagnetic lenses made up of spaced conducting planes, from slots cut in a piece of metal, from dielectric wires, or from the open end of a waveguide.

Directivity of Radiation The radiation from any physically practical radiating system is directive to a certain degree. The degree of directivity can be enhanced or altered when desirable through the combination of radiating elements in a prescribed manner, through the use of reflecting planes or curved surfaces, or through the use of such systems as mentioned in the preceding paragraph. The construction of directive antenna arrays is covered in detail in the chapters which follow.

Polarization Like light waves, radio waves can have a definite polarization. In fact, while light waves ordinarily have to be reflected or passed through a polarizing medium before they have a definite polarization, a radio wave leaving a simple radiator will have a definite polarization, the polarization being indicated by the orientation of the electric-field component of the wave. This, in turn, is determined by the orientation of the radiator itself, as the magnetic-field component is always at right angles to a linear radiator, and the electric-field component is always in the same plane as the radiator. Thus we see that an antenna that is vertical with respect to the earth will transmit a vertically polarized wave, as the

electrostatic lines of force will be vertical. Likewise, a simple horizontal antenna will radiate horizontally polarized waves.

Because the orientation of a simple linear radiator is the same as the polarization of the waves emitted by it, the radiator itself is referred to as being either vertically or horizontally polarized. Thus, we say that a horizontal antenna is horizontally polarized.

Figure 2A illustrates the fact that the polarization of the electric field of the radiation from a vertical dipole is vertical. Figure 2B, on the other hand, shows that the polarization of electric-field radiation from a vertical *slot* radiator is horizontal. This fact has been utilized in certain commercial f-m antennas where it is desired to have horizontally polarized radiation but where it is more convenient to use an array of vertically stacked slot arrays. If the metallic sheet is bent into a cylinder with the slot on one side, substantially omnidirectional horizontal coverage is obtained with horizontally polarized radiation when the cylinder with the slot in one side is oriented vertically. An arrangement of this type is shown in figure 2C. Several such cylinders may be stacked vertically to reduce high-angle radiation and to concentrate the radiated energy at the useful low radiation angles.

In any event the polarization of radiation from a radiating system is parallel to the electric field as it is set up inside or in the vicinity of the radiating system.

20-2 General Characteristics of Antennas

All antennas have certain general characteristics to be enumerated. It is the result of differences in these general characteristics which makes one type of antenna system most suitable for one type of application and another type best for a different application. Six of the more important characteristics are: (1) polarization, (2) radiation resistance, (3) horizontal directivity, (4) vertical directivity, (5) bandwidth, and (6) effective power gain.

The *polarization* of an antenna or radiating system is the direction of the electric field and has been defined in Section 20-1.

The *radiation resistance* of an antenna system is normally referred to the feed point

Figure 2

ANTENNA POLARIZATION

The polarization (electric field) of the radiation from a resonant dipole such as shown at A is parallel to the length of the radiator. In the case of a resonant slot cut in a sheet of metal and used as a radiator, the polarization (of the electric field) is perpendicular to the length of the slot. In both cases, however, the polarization of the radiated field is parallel to the potential gradient of the radiator; in the case of the dipole the electric lines of force are from end to end, while in the case of the slot the field is across the sides of the slot. The metallic sheet containing the slot may be formed into a cylinder to make up the radiator shown at C. With this type of radiator the radiated field will be horizontally polarized even though the radiator is mounted vertically.

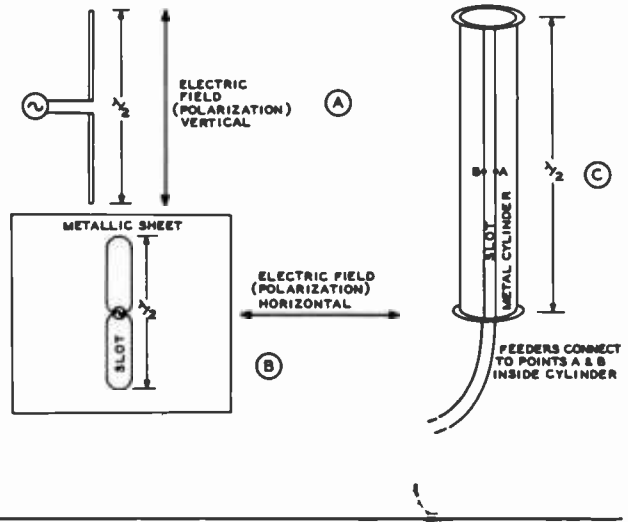

in an antenna fed at a current loop, or it is referred to a current loop in an antenna system fed at another point. The radiation resistance is that value of resistance which, when substituted for the antenna at a current loop, would dissipate the same energy as is actually radiated by the antenna if the antenna current at the feed point were to remain the same.

The *horizontal and vertical directivity* can best be expressed as a *directive pattern* which is a graph showing the relative radiated field intensity against *azimuth* angle for horizontal directivity and field intensity against *elevation* angle for vertical directivity.

The *bandwidth* of an antenna is a measure of its ability to operate within specified limits over a range of frequencies. Bandwidth can be expressed as either *operating frequency plus or minus a specified percent of operating frequency*, or *operating frequency plus or minus a specified number of MHz for a certain standing-wave-ratio limit* on the transmission line feeding the antenna system.

The *effective power gain* or *directive gain* of an antenna is the ratio between the power required in the specified antenna and the power required in a reference antenna (usually a half-wave dipole) to attain the same field strength in the favored direction of the antenna under measurement. Directive gain

may be expressed either as an actual power ratio, or as is more common, the power ratio may be expressed in decibels.

Physical Length of a Half-Wave Antenna If the cross section of the conductor which makes up the antenna is kept very

small with respect to the antenna length, an electrical half wave is a fixed percentage shorter than a physical half wavelength. This percentage is approximately 5 percent. Therefore, most linear half-wave antennas are close to 95 percent of a half wavelength long physically. Thus, a half-wave antenna resonant at exactly 80 meters would be one-half of 0.95 times 80 meters in length. Another way of saying the same thing is that a wire resonates at a wavelength of about 2.1 times its length in meters. If the diameter of the conductor begins to be an appreciable fraction of a wavelength, as when tubing is used as a vhf radiator, the factor becomes slightly less than 0.95. For the use of wire and not tubing on frequencies below 30 MHz, however, the figure of 0.95 may be taken as accurate. This assumes a radiator removed from surrounding objects, and with *no bends*.

Simple conversion into feet can be obtained by using the factor 1.56. To find the physical length of a half-wave 80-meter antenna, we multiply 80 times 1.56, and get 124.8 feet for the length of the radiator.

It is more common to use frequency than wavelength when indicating a specific spot in the radio spectrum. For this reason, the relationship between wavelength and frequency must be kept in mind. As the velocity of radio waves through space is constant at the speed of light, it will be seen that the more waves that pass a point per second (higher frequency), the closer together the peaks of those waves must be (shorter wavelength). Therefore, the higher the frequency, the lower will be the wavelength.

A radio wave in space can be compared to a wave in water. The wave, in either case, has peaks and troughs. One peak and one trough constitute a *full wave*, or *one wavelength*.

Frequency describes the number of wave cycles or peaks passing a point per second. *Wavelength* describes the distance the wave travels through space during one cycle or oscillation of the antenna current; it is the distance in meters between adjacent peaks or adjacent troughs of a wave train.

As a radio wave travels 300,000,000 meters a second (speed of light), a frequency of 1 cycle per second (1 Hz) corresponds to a wavelength of 300,000,000 meters. So, if the frequency is multiplied by a million, the wavelength must be divided by a million, in order to maintain their correct ratio.

A frequency of 1,000,000 cycles per second (1000 kHz) equals a wavelength of 300 meters. Multiplying frequency by 10 and dividing wavelength by 10, we find: a frequency of 10,000 kHz equals a wavelength of 30 meters. Multiplying and dividing by 10 again, we get: a frequency of 100,000 kHz equals 3 meters wavelength. Therefore, to change wavelength to frequency (in kilohertz), simply divide 300,000 by the wavelength in meters (λ).

$$F_{kHz} = \frac{300,000}{\lambda}$$

$$\lambda = \frac{300,000}{F_{kHz}}$$

Now that we have a simple conversion formula for converting wavelength to frequency and vice versa, we can combine it with our wavelength-versus-antenna length formula, and we have the following:

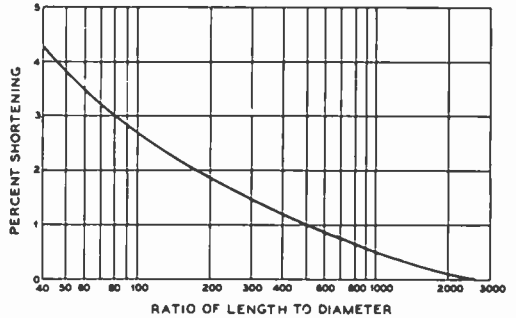

Figure 3

CHART SHOWING SHORTENING OF A RESONANT ELEMENT IN TERMS OF RATIO OF LENGTH TO DIAMETER

The use of this chart is based on the basic formula where radiator length in feet is equal to 475/frequency in MHz. This formula applies to frequencies below perhaps 30 MHz when the radiator is made from wire. On higher frequencies, or on 14 and 28 MHz when the radiator is made of large-diameter tubing, the radiator is shortened from the value obtained with the above formula by an amount determined by the ratio of length to diameter of the radiator. The amount of this shortening is obtainable from the chart shown above.

Length of a half-wave radiator made from wire (No. 14 to No. 10):

3.5-MHz to 30-MHz bands

$$\text{Length in feet} = \frac{475}{\text{Freq. in MHz}}$$

50-MHz band

$$\text{Length in feet} = \frac{466}{\text{Freq. in MHz}}$$

$$\text{Length in inches} = \frac{5600}{\text{Freq. in MHz}}$$

144-MHz band

$$\text{Length in inches} = \frac{5600}{\text{Freq. in MHz}}$$

Length-to-Diameter Ratio When a half-wave radiator is constructed from tubing or rod whose diameter is an appreciable fraction of the length of the radiator, the resonant length of a half-wave antenna will be shortened. The amount of shortening can be deter-

mined with the aid of the chart of figure 3. In this chart the amount of additional shortening over the values given in the previous paragraph is plotted against the ratio of the length to the diameter of the half-wave radiator.

The length of a wave in free space is somewhat longer than the length of an antenna for the same frequency. The actual free-space half wavelength is given by the following expressions:

$$\text{Half wavelength} = \frac{492}{\text{Freq. in MHz}} \text{ in feet}$$

$$\text{Half wavelength} = \frac{5905}{\text{Freq. in MHz}} \text{ in inches}$$

Harmonic Resonance A wire in space can resonate at more than one frequency. The lowest frequency at which it resonates is called its *fundamental* frequency, and at that frequency it is approximately a half wavelength long. A wire can have two, three, four, five, or more standing waves on it, and thus it resonates at approximately the integral harmonics of its fundamental frequency. However, the higher harmonics are not exactly integral multiples of the lowest resonant frequency as a result of *end effects*.

A harmonic-operated antenna is somewhat longer than the corresponding integral number of dipoles, and for this reason, the dipole length formula cannot be used simply by multiplying by the corresponding harmonic. The intermediate half-wave sections do not have *end effects*. Also, the current distribution is disturbed by the fact that power can reach some of the half-wave sections only by flowing through other sections, the latter then acting not only as radiators, but also as transmission lines. For the latter reason, the resonant length will be dependent to an extent on the method of feed, as there will be less attenuation of the current along the antenna if it is fed at or near the center than if fed toward or at one end. Thus, the antenna would have to be somewhat longer if fed near one end than if fed near the center. The difference would be small, however, unless the antenna were many wavelengths long.

The length of a center-fed harmonically operated doublet may be found from the formula:

$$L = \frac{(K - .05) \times 492}{\text{Freq. in MHz}}$$

where,

K equals number of 1/2 waves on antenna,
L equals length in feet.

Under conditions of severe current attenuation, it is possible for some of the nodes, or loops, actually to be slightly greater than a physical half wavelength apart. Practice has shown that the most practical method of resonating a harmonically operated antenna accurately is by cut and try, or by using a feed system in which both the feedline and antenna are resonated at the station end as an integral system.

A dipole or half-wave antenna is said to operate on its fundamental or first harmonic. A full-wave antenna, 1 wavelength long, operates on its second harmonic. An antenna with five half wavelengths on it would be operating on its fifth harmonic. Observe that the fifth harmonic antenna is 2 1/2 wavelengths long, not 5 wavelengths.

Antenna Resonance Most types of antennas operate most efficiently when tuned, or *resonated*, to the frequency of operation. This consideration of course does not apply to the rhombic antenna and to the parasitic elements of Yagi arrays. However,

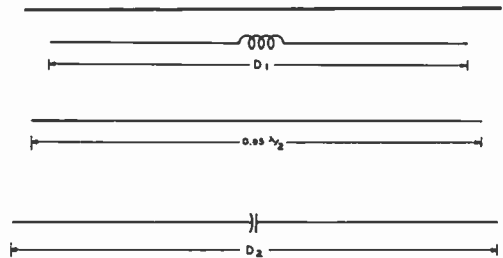

Figure 4

EFFECT OF SERIES INDUCTANCE AND CAPACITANCE ON THE LENGTH OF A HALF-WAVE RADIATOR

The top antenna has been electrically lengthened by placing a coil in series with the center. In other words, an antenna with a lumped inductance in its center can be made shorter for a given frequency than a plain wire radiator. The bottom antenna has been capacitively shortened electrically. In other words, an antenna with a capacitor in series with it must be made longer for a given frequency since its effective electrical length as compared to plain wire is shorter.

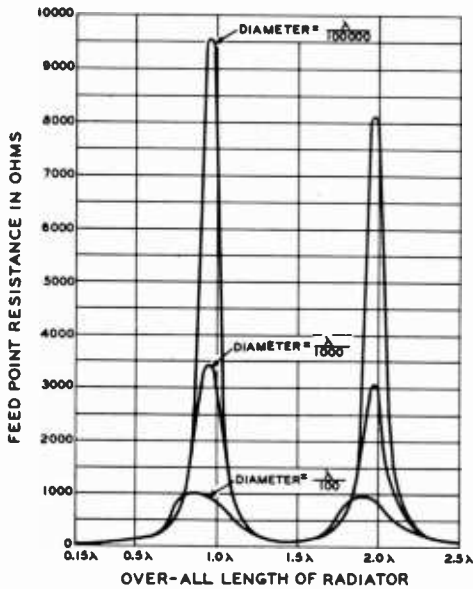

Figure 5

FEED-POINT RESISTANCE OF A CENTER-DRIVEN RADIATOR AS A FUNCTION OF PHYSICAL LENGTH IN TERMS OF FREE SPACE WAVELENGTH

in practically every other case it will be found that increased efficiency results when the entire antenna system is resonant, whether it be a simple dipole or an elaborate array. The radiation efficiency of a resonant wire is many times that of a wire which is not resonant.

If an antenna is slightly too long, it can be resonated by series insertion of a variable capacitor at a high-current point. If it is slightly too short, it can be resonated by means of a variable inductance. These two methods, illustrated schematically in figure 4, are generally employed when part of the antenna is brought into the operating room.

With an antenna array, or an antenna fed by means of a transmission line, it is more common to cut the elements to exact resonant length by "cut-and-try" procedure. Exact antenna resonance is more important when the antenna system has low radiation resistance; an antenna with low radiation resistance has higher Q (tunes sharper) than an antenna with high radiation resistance. The higher Q does not indicate greater effi-

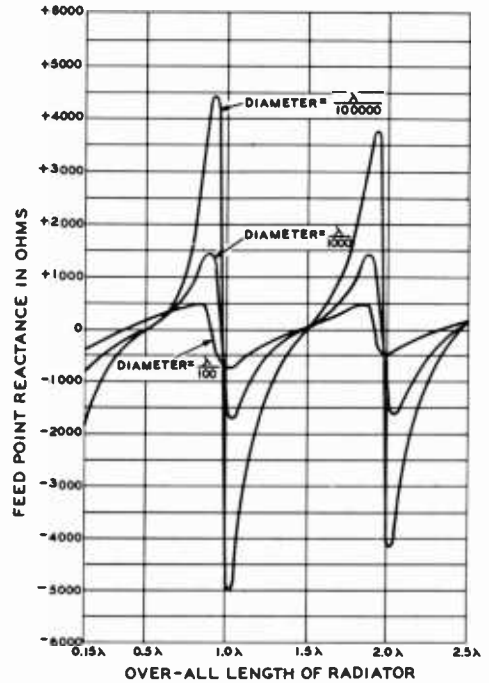

Figure 6

REACTIVE COMPONENT OF THE FEED-POINT IMPEDANCE OF A CENTER-DRIVEN RADIATOR AS A FUNCTION OF PHYSICAL LENGTH IN TERMS OF FREE-SPACE WAVELENGTH

ciency; it simply indicates a sharper resonance curve.

20-3 Radiation Resistance and Feed-point Impedance

In many ways, a half-wave antenna is like a tuned tank circuit. The main difference lies in the fact that the elements of inductance, capacitance, and resistance are *lumped* in the tank circuit, and are *distributed* throughout the length of an antenna. The center of a half-wave radiator is effective at ground potential as far as r-f voltage is concerned, although the current is highest at that point.

When the antenna is resonant, and it always should be for best results, the impedance at the center is substantially resistive, and is termed the *radiation resistance*. Radiation resistance is a fictitious term; it is that

value of resistance (referred to the current loop) which would dissipate the same amount of power as being radiated by the antenna, when fed with the current flowing at the current loop.

The radiation resistance depends on the antenna length and its proximity to nearby objects which either absorb or re-radiate power, such as the ground, other wires, etc.

The Marconi Antenna Before going too far with the discussion of radiation resistance, an explanation of the *Marconi* (grounded quarter-wave) antenna is in order. The Marconi antenna is a special type of Hertz antenna in which the earth acts as the "other half" of the dipole. In other words, the current flows into the earth instead of into a similar quarter-wave section. Thus, the current loop of a Marconi antenna is at the *base* rather than in the *center*.

A half-wave dipole far from ground and other reflecting objects has a radiation resistance at the center of about 73 ohms. A Marconi antenna is simply one-half of a dipole. For that reason, the radiation resistance is roughly half the 73-ohm impedance of the dipole, or 36.5 ohms. The radiation resistance of a Marconi antenna, such as a mobile whip, will be lowered by the proximity of the automobile body.

Antenna Impedance Because the power throughout the antenna is the same, the *impedance* of a resonant antenna at any point along its length merely expresses the ratio between voltage and current at that point. Thus, the lowest impedance occurs where the current is highest, namely, at the center of a dipole, or a quarter wave from the end of a Marconi. The impedance rises uniformly toward each end, where it is about 2000 ohms for a dipole remote from ground, and about twice as high for a vertical Marconi.

If a vertical half-wave antenna is set up so that its lower end is at the ground level, the effect of the ground reflection is to increase the radiation resistance to approximately 100 ohms. When a horizontal half-wave antenna is used, the radiation resistance (and, of course, the amount of energy radiated for a given antenna current) depends on the height of the antenna above

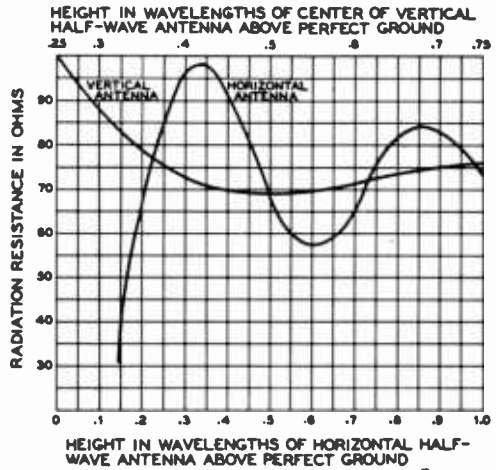

Figure 7

EFFECT OF HEIGHT ON THE RADIATION RESISTANCE OF A DIPOLE SUSPENDED ABOVE PERFECT GROUND

ground, since the height determines the phase and amplitude of the wave reflected from the ground back to the antenna. Thus the resultant current in the antenna for a given power is a function of antenna height.

Center-Fed Feed-Point Impedance When a linear radiator is series fed at the center, the resistive and reactive components of the driving-point impedance are dependent on both the length and diameter of the radiator expressed in wavelengths. The manner in which the resistive component varies with the physical dimensions of the radiator is illustrated in figure 5. The manner in which the reactive component varies is illustrated in figure 6.

Several interesting things will be noted with respect to these curves. The reactive component disappears when the over-all physical length is slightly less than any number of half waves long, the differential increasing with conductor diameter. For over-all lengths in the vicinity of an odd number of half wavelengths, the center feed point looks like a series-resonant lumped circuit to the generator or transmission line, while for over-all lengths in the vicinity of an *even* number of half wavelengths, it looks like a parallel-resonant or antiresonant

lumped circuit. Both the feed-point resistance and the feed-point reactance *change more slowly* with over-all radiator length (or with frequency with a fixed length) *as the conductor diameter is increased*, indicating that the effective Q is lowered as the diameter is increased. However, in view of the fact that the damping resistance is nearly all radiation resistance rather than loss resistance, the lower Q does not represent lower efficiency. Therefore, the lower Q is desirable, because it permits use of the radiator over a wider frequency range without resorting to means for eliminating the reactive component. Thus, the use of a large diameter conductor makes the over-all system less frequency sensitive. If the diameter is made sufficiently large in terms of wavelengths, the Q will be low enough to qualify the radiator as a *broadband* antenna.

The curves of figure 7 indicate the theoretical center-point radiation resistance of a half-wave antenna for various heights above perfect ground. These values are of importance in matching untuned radio-frequency feeders to the antenna, in order to obtain a good impedance match and an absence of standing waves on the feeders.

Ground Losses Above *average* ground, the actual radiation resistance of a dipole will vary from the exact value of figure 7 since the latter assumes a hypothetical, perfect ground having no loss and perfect reflection. Fortunately, the curves for the radiation resistance over most types of earth will correspond rather closely with those of the chart, except that the radiation resistance for a horizontal dipole does not fall off as rapidly as is indicated for heights below an eighth wavelength. However, with the antenna so close to the ground and the soil in a strong field, much of the radiation resistance is actually represented by ground loss; this means that a good portion of the antenna power is being dissipated in the earth, which, unlike the hypothetical perfect ground, has resistance. In this case, an appreciable portion of the *radiation resistance* actually is loss resistance. The type of soil also has an effect upon the radiation *pattern*, especially in the vertical plane, as will be seen later.

The radiation resistance of an antenna generally increases with length, although this increase varies up and down about a constantly increasing average. The peaks and dips are caused by the reactance of the antenna, when its length does not allow it to resonate at the operating frequency.

Antenna Efficiency Antennas have a certain loss resistance as well as a radiation resistance. The loss resistance defines the power lost in the antenna due to ohmic resistance of the wire, ground resistance (in the case of a Marconi), corona discharge, and insulator losses.

The approximate effective radiation efficiency (expressed as a decimal) is equal to:

$$N_r = \frac{R_a}{R_a + R_l}$$

where,

R_a equals the radiation resistance,

R_l equals loss resistance of antenna.

The loss resistance will be of the order of 0.25 ohm for large-diameter tubing conductors such as are most commonly used in multi-element parasitic arrays, and will be of the order of 0.5 to 2.0 ohms for arrays of normal construction using copper wire.

When the radiation resistance of an antenna or array is very low, the current at a voltage node will be quite high for a given power. Likewise, the voltage at a current node will be very high. Even with a heavy conductor and excellent insulation, the losses due to the high voltage and current will be appreciable if the radiation resistance is sufficiently low.

Usually, it is not considered desirable to use an antenna or array with a radiation resistance of less than approximately 5 ohms unless there is sufficient directivity, compactness, or other advantage to offset the losses resulting from the low radiation resistance.

Ground Resistance The radiation resistance of a Marconi antenna, especially, should be kept as high as possible. This will reduce the antenna current for a given power, thus minimizing loss resulting from the series resistance offered by the earth connection. The radiation resist-

ance can be kept high by making the Marconi radiator somewhat longer than a quarter wave, and shortening it by series capacitance to an electrical quarter wave. This reduces the current flowing in the earth connection. It also should be removed from ground as much as possible (vertical being ideal). Methods of minimizing the resistance of the earth connection will be found in the discussion of the Marconi antenna.

20-4 Antenna Directivity

All practical antennas radiate better in some directions than others. This characteristic is called *directivity*. The more *directive* an antenna is, the more it concentrates the radiation in a certain direction, or directions. The more the radiation is concentrated in a certain direction, the greater will be the field strength produced in that direction for a given amount of total radiated power. Thus the use of a directional antenna or *array* produces the same result in the favored direction as an increase in the power of the transmitter.

The increase in radiated power in a certain direction with respect to an antenna in free space as a result of inherent directivity is called the *free-space directivity power gain* or just *space directivity gain* of the antenna (referred to a hypothetical *isotropic radiator* which is assumed to radiate equally well in all directions). Because the fictitious isotropic radiator is a purely academic antenna, not physically realizable, it is common practice to use as a reference antenna the simplest ungrounded resonant radiator, the half-wave dipole, or resonant doublet. As a half-wave doublet has a space directivity gain of 2.15 db over an isotropic radiator, the use of a resonant dipole as the comparison antenna reduces the *gain figure* of an array by 2.15 db. However, it should be understood that power gain can be expressed with regard to *any* antenna, just so long as it is specified.

As a matter of interest, the directivity of an *infinitesimal dipole* provides a free-space directivity power gain of 1.5 (or 1.76 db) over an isotropic radiator. This means that *in the direction of maximum radiation* the infinitesimal dipole will produce the same field of strength as an isotropic radiator which is radiating 1.5 times as much total power.

A half-wave resonant doublet, because of its different current distribution and significant length, exhibits slightly more free-space power gain as a result of directivity than does the infinitesimal dipole, for reasons which will be explained in a later section. The space-directivity power gain of a half-wave resonant doublet is 1.63 (or 2.15 db) referred to an isotropic radiator.

Horizontal Directivity When choosing and orienting an antenna system, the radiation patterns of the various common types of antennas should be given careful consideration. The directional characteristics are of still greater importance when a directive antenna array is used.

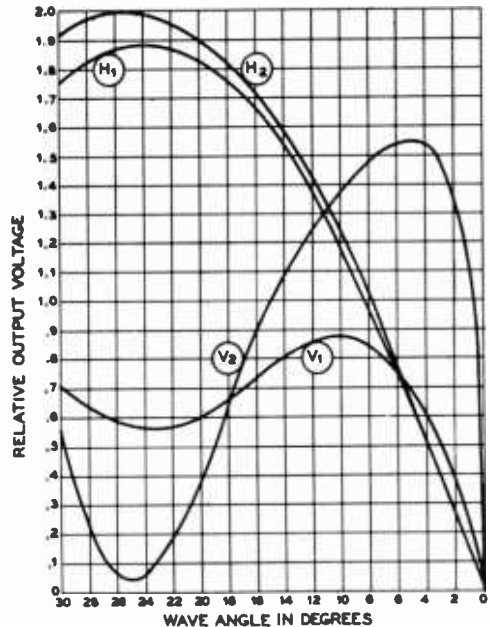

Figure 8

VERTICAL-PLANE DIRECTIONAL CHARACTERISTICS OF HORIZONTAL AND VERTICAL DOUBLET'S ELEVATED 0.6 WAVELENGTH AND ABOVE TWO TYPES OF GROUND

H₁ represents a horizontal doublet over typical farmland. *H₂* over salt water. *V₁* is a vertical pattern of radiation from a vertical doublet over typical farmland, *V₂* over salt water. A salt water ground is the closest approach to an extensive ideally perfect ground that will be met in actual practice.

Horizontal directivity is always desirable on any frequency for point-to-point work. However, it is not always attainable with reasonable antenna dimensions on the lower frequencies. Further, when it is attainable, as on the frequencies above perhaps 7 MHz, with reasonable antenna dimensions, operating convenience is greatly furthered if the maximum lobe of the horizontal directivity is controllable. It is for this reason that rotatable antenna arrays have come into such common usage.

Considerable horizontal directivity can be used to advantage when: (1) only point-to-point work is necessary, (2) several arrays are available so that directivity may be changed by selecting or reversing antennas, (3) a single rotatable array is in use. Signals follow the great-circle path, or within 2 or 3 degrees of that path under all normal propagation conditions. However, under turbulent ionospheric conditions, or when unusual propagation conditions exist, the deviation from the great-circle path for greatest signal intensity may be as great as 90°. Making the array rotatable overcomes these difficulties, but arrays having extremely high horizontal directivity become too cumbersome to be rotated, except perhaps when designed for operation on frequencies above 50 MHz.

Vertical Directivity Vertical directivity is of the greatest importance in obtaining satisfactory communication above 14 MHz whether or not horizontal directivity is used. This is true simply because *only* the energy radiated between certain definite *elevation* angles is useful for communication. Energy radiated at other elevation angles is lost and performs no useful function.

Optimum Angle of Radiation The optimum angle of radiation for propagation of signals between two points is dependent on a number of variables. Among these significant variables are: (1) height of the ionosphere layer which is providing the reflection, (2) distance between the two stations, (3) number of hops for propagation between the two stations. For communication on the 14-MHz band it is often possible for different modes of propagation to provide signals between two

points. This means, of course, that more than one angle of radiation can be used. If *no* elevation directivity is being used under this condition of propagation, selective fading will take place because of interference between the waves arriving over the different paths.

On the 28-MHz band it is by far the most common condition that only one mode of propagation will be possible between two points at any one time. This explains, of course, the reason why rapid fading in general and selective fading in particular are almost absent from signals heard on the 28-MHz band (except for fading caused by local effects).

Measurements have shown that the angles useful for communication on the 14-MHz band are from 3° to about 30°, angles above about 15° being useful only for local work. On the 28-MHz band, measurements have shown that the useful angles range from about 3° to 18°; angles above about 12° being useful only for local (less than 3000 miles) work. These figures assume normal propagation by virtue of the F_2 layer.

Angle of Radiation of Typical Antennas and Arrays It now becomes of interest to determine the amount of radiation available at these useful lower angles of radiation from commonly used antennas and antenna arrays. Figure 8 shows relative output voltage plotted against elevation angle (wave angle) in degrees above the horizontal, for horizontal and vertical doublets elevated 0.6 wavelength above two types of ground. It is obvious by inspection of the curves that a horizontal dipole mounted at this height above ground (20 feet on the 28-MHz band) is radiating only a small amount of energy at angles useful for communication on the 28-MHz band. Most of the energy is being radiated uselessly upward. The vertical antenna above a good reflecting surface appears much better in this respect—and this fact has been proven many times by actual installations.

It might immediately be thought that the amount of radiation from a horizontal or vertical dipole could be increased by raising the antenna higher above the ground. This is true to an extent in the case of the hori-

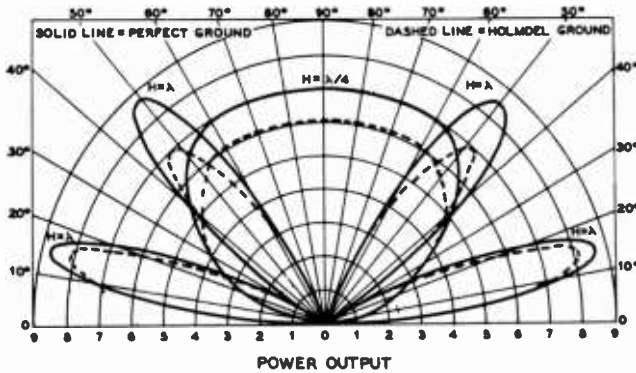

Figure 9

VERTICAL RADIATION PATTERNS

Showing the vertical radiation patterns for half-wave antennas (or collinear half-wave or extended half-wave antennas) at different heights above average ground and perfect ground. Note that such antennas one-quarter wave above ground concentrate most of the radiation at the very high angles which are useful for communication only on the lower-frequency bands. Antennas one-half wave above ground are not shown, but the elevation pattern shows one lobe on each side at an angle of 30° above horizontal.

zontal dipole; the low-angle radiation does increase slowly after a height of 0.6 wavelength is reached but at the expense of greatly increased high-angle radiation and the formation of a number of nulls in the elevation pattern. No signal can be transmitted or received at the elevation angles where these nulls have been formed. Tests have shown that a center height of 0.6 wavelength for a vertical dipole (0.35 wavelength to the bottom end) is about optimum for this type of array.

Figure 9 shows the effect of placing a horizontal dipole at various heights above ground. It is easily seen by reference to figure 9 (and figure 10 which shows the radiation from a dipole at $\frac{3}{4}$ wave height) that a large percentage of the total radiation from the dipole is being radiated at relatively high angles which are useless for communication on the 14-MHz and 28-MHz bands. Thus we see that in order to obtain a worthwhile increase in the ratio of low-angle

radiation to high-angle radiation it is necessary to place the antenna high above ground, and in addition it is necessary to use additional means for suppressing high-angle radiation.

Suppression of High-angle Radiation High-angle radiation can be suppressed, and this radiation can be added to that going out at low angles, only through the use of some sort of directive antenna system. There are three general types of antenna arrays composed of dipole elements commonly used which concentrate radiation at the lower more effective angles for high-frequency communication. These types are: (1) The close-spaced out-of-phase system as exemplified by the "flat-top" beam, or W8JK array. Such configurations are classified as *end-fire arrays*. (2) The wide-spaced in-phase arrays, as exemplified by the "Lazy H" antenna. These configurations are classified as *broadside arrays*. (3) The close-

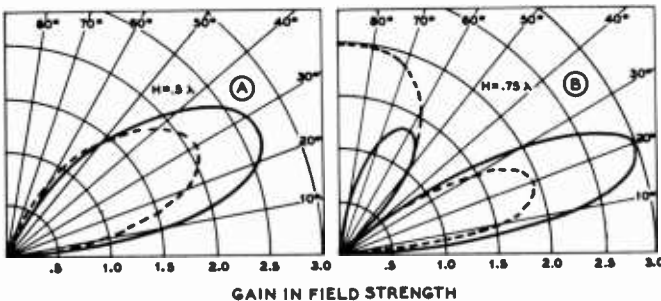

Figure 10

VERTICAL RADIATION PATTERNS

Showing vertical-plane radiation patterns of a horizontal single-section flat-top beam with one-eighth wave spacing (solid curves) and a horizontal half-wave antenna (dashed curves) when both are 0.5 wavelength (A) and 0.75 wavelength (B) above ground.

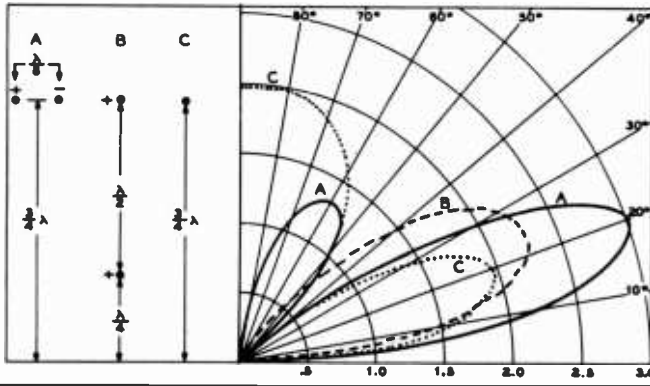

Figure 11
COMPARATIVE VERTICAL RADIATION PATTERNS

Showing the vertical radiation patterns of a horizontal single-section flat-top beam (A), an array of two stacked horizontal in-phase half-wave elements — half of a "Lazy H" — (B), and a horizontal dipole (C). In each case the top of the antenna system is 0.75 wavelength above ground, as shown to the left of the curves.

spaced parasitic systems, as exemplified by the three-element rotary beam.

A comparison between the radiation from a dipole, a "flat-top beam" and a pair of dipoles stacked one above the other (half of a "lazy H"), in each case with the top of the antenna at a height of $\frac{3}{4}$ wavelength is shown in figure 11. The improvement in the amplitude of low-angle radiation at the expense of the useless high-angle radiation with these simple arrays as contrasted to the dipole is quite marked.

Figure 12 compares the patterns of a 3-element beam and a dipole radiator at a height of 0.75 wavelength. It will be noticed that although there is more energy in the lobe of the beam as compared to the dipole, the axis of the beam is at the same angle above the horizontal. Thus, although more radiated energy is provided by the beam at low angles, the average angle of radiation of the beam is no lower than the average angle of radiation of the dipole.

20-5 Bandwidth

The *bandwidth* of an antenna or an antenna array is a function primarily of the radiation resistance and of the shape of the conductors which make up the antenna system. For arrays of essentially similar construction the bandwidth (or the deviation in frequency which the system can handle without mismatch) is increased with increasing radiation resistance, and the bandwidth is increased with the use of conductors of large diameter (smaller ratio of length to diameter). This is to say that if an array of any type is constructed of large diameter tubing or spaced wires,

its bandwidth will be greater than that of a similar array constructed of single wires.

The radiation resistance of antenna arrays of the types mentioned in the previous paragraphs may be increased through the use of wider spacing between elements. With increased radiation resistance in such arrays the *radiation efficiency* increases since the ohmic losses within the conductors become a smaller percentage of the radiation resistance, and the bandwidth is increased proportionately.

20-6 Propagation of Radio Waves

The preceding sections have discussed the manner in which an electromagnetic-wave

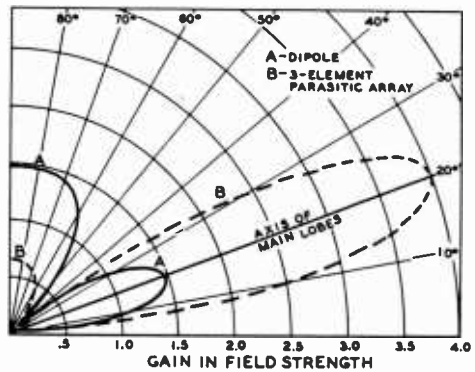

Figure 12
VERTICAL RADIATION PATTERNS

Showing vertical radiation patterns of a horizontal dipole (A) and a horizontal 3-element parasitic array (B) at a height above ground of 0.75 wavelength. Note that the axes of the main radiation lobes are at the same angle above the horizontal. Note also the suppression of high angle radiation by the parasitic array.

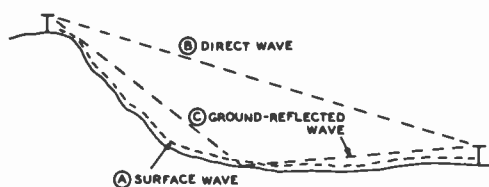

Figure 13

GROUND-WAVE SIGNAL PROPAGATION

The illustration above shows the three components of the ground wave: A, the surface wave; B, the direct wave; and C, the ground-reflected wave. The direct wave and the ground-reflected wave combine at the receiving antenna to make up the space wave.

or radio-wave field may be set up by a radiating system. However, for this field to be useful for communication it must be propagated to some distant point where it can be received, or where it may be reflected so that it can be received at some other point. Radio waves may be propagated to a remote point by either or both of two general methods. Propagation may take place as a result of the *ground wave*, or as a result of the *sky wave* or *ionospheric wave*.

The Ground Wave The term *ground wave* actually includes several different types of waves which usually are called: (1) the *surface wave*, (2) the *direct wave*, and (3) the *ground-reflected wave*. The latter two waves combine at the receiving antenna to form the *resultant wave* or the *space wave*. The distinguishing characteristic of the components of the ground wave is that all travel along or over the surface of the earth, so that they are affected by the conductivity and terrain of the earth's surface.

The Ionospheric Wave or Sky Wave Intense bombardment of the upper regions of the atmosphere by radiations from the sun results in the formation of ionized layers. These ionized layers, which form the *ionosphere*, have the capability of reflecting or refracting radio waves which impinge on them. A radio wave which has been propagated as a result of one or more reflections from the ionosphere is

known as an *ionospheric wave* or a *sky wave*. Such waves make possible long distance radio communication. Propagation of radio signals by ionospheric waves is discussed in detail in Section 20-8.

20-7 Ground-Wave Communication

As stated in the preceding paragraph, the term *ground wave* applies both to the *surface wave* and to the *space wave* (the resultant wave from the combination of the direct wave and the ground-reflected wave) or to a combination of the two. The three waves which may combine to make up the ground wave are illustrated in figure 13.

The Surface Wave The surface wave is that wave which we normally receive from a standard broadcast station. It travels directly along the ground and terminates on the earth's surface. Since the earth is a relatively poor conductor, the surface wave is attenuated quite rapidly. The surface wave is attenuated less rapidly as it passes over sea water, and the attenuation decreases for a specific distance as the frequency is decreased. The rate of attenuation with distance becomes so large as the frequency is increased above about 3 MHz that the surface wave becomes of little value for communication.

The Space Wave The resultant wave or space wave is illustrated in figure 13 by the combination of B and C. It is this wave path, which consists of the combination of the direct wave and the ground-reflected wave at the receiving antenna, which is the *normal* path of signal propagation for line-of-sight or near line-of-sight communication or f-m and TV reception on frequencies above about 40 MHz.

Below line-of-sight over plane earth or water, when the signal source is effectively at the horizon, the ground-reflected wave does not exist, so that the *direct wave* is the only component which goes to make up the space wave. But when both the signal source and the receiving antenna are elevated with respect to the intervening terrain, the ground-reflected wave is present and adds vectorially to the direct wave at the receiving antenna. The vectorial addition of the

two waves, which travel over different path lengths (since one of the waves has been reflected from the ground) results in an interference pattern. The interference between the two waves brings about a cyclic variation in signal strength as the receiving antenna is raised above the ground. This effect is illustrated in figure 14. From this figure it can be seen that best spacewave reception of a vhf signal often will be obtained with the receiving antenna quite close to the ground.

The distance from an elevated point to the geometrical horizon is given by the approximate equation: $d = 1.22\sqrt{H}$ where distance d is in miles and antenna height H is in feet. This equation must be applied separately to the transmitting and receiving antennas and the results added. However,

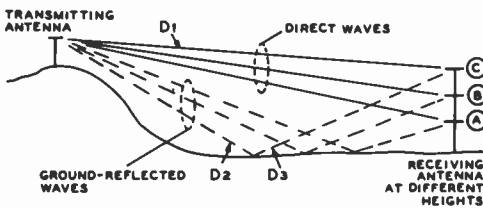

Figure 14

WAVE INTERFERENCE WITH HEIGHT

When the source of a horizontally-polarized space-wave signal is above the horizon, the received signal at a distant location will go through a cyclic variation as the antenna height is progressively raised. This is due to the difference in total path length between the direct wave and the ground-reflected wave, and to the fact that this path length difference changes with antenna height. When the path length difference is such that the two waves arrive at the receiving antenna with a phase difference of 360° or some multiple of 360° , the two waves will appear to be in phase as far as the antenna is concerned and maximum signal will be obtained. On the other hand, when the antenna height is such that the path length difference for the two waves causes the waves to arrive with a phase difference of an odd multiple of 180° the two waves will substantially cancel, and a null will be obtained at that antenna height. The difference between D_1 and D_2 plus D_3 is the path-length difference. Note also that there is an additional 180° phase shift in the ground-reflected wave at the point where it is reflected from the ground. It is this latter phase shift which causes the space-wave field intensity of a horizontally polarized wave to be zero with the receiving antenna at ground level.

refraction and diffraction of the signal around the spherical earth cause a smaller reduction in field strength than would occur in the absence of such bending, so that the average radio horizon is somewhat beyond the geometrical horizon. The equation $d = 1.4\sqrt{H}$ is sometimes used for determining the radio horizon.

Tropospheric Propagation Propagation by signal bending in the lower atmosphere, called *tropospheric propagation*, can result in the reception of signals over a much greater distance than would be the case if the lower atmosphere were homogeneous. In a homogeneous or well-mixed lower atmosphere, called a *normal*, or *standard*, atmosphere, there is a gradual and uniform decrease in index of refraction with height. This effect is due to the combined effects of a decrease in temperature, pressure, and water-vapor content with height.

This gradual decrease in refractive index with height causes waves radiated at very low angles with respect to the horizontal to be bent downward slightly in a curved path. The result of this effect is that such waves will be propagated beyond the *true*, or *geometrical*, horizon. In a so-called standard atmosphere the effect of the curved path is the same as though the radius of the earth were increased by approximately one-third. This condition extends the horizon by approximately 30 percent for normal propagation, and the extended horizon is known as the *radio-path horizon*, mentioned before.

Conditions Leading to Tropospheric Stratification When the temperature, pressure, or water-vapor content of the atmosphere does not change smoothly with rising altitude, the discontinuity or stratification will result in the reflection or refraction of incident vhf signals. Ordinarily this condition is more prevalent at night and in the summer. In certain areas, such as along the west coast of North America, it is frequent enough to be considered normal. Signal strength decreases slowly with distance and, if the favorable condition in the lower atmosphere covers sufficient area, the range is limited only by the transmitter power, antenna gain, receiver sensitivity, and signal-to-noise ratio. There is no skip distance. Usually, transmis-

sion due to this condition is accompanied by slow fading, although fading can be violent at a point where direct waves of about the same strength are also received.

Bending in the troposphere, which refers to the region from the earth's surface up to about 10 kilometers, is more likely to occur on days when there are stratus clouds than on clear, cool days with a deep blue sky. The temperature or humidity discontinuities may be broken up by vertical convection currents over land in the daytime but are more likely to continue during the day over water. This condition is in some degree predictable from weather information several days in advance. It does not depend on the sunspot cycle. Like direct communication, best results require similar antenna polarization or orientation at both the transmitting and receiving ends, whereas in transmission via reflection in the ionosphere (that part of the atmosphere between about 50 and 500 kilometers high) it makes little difference whether antennas are similarly polarized.

Duct Formation When bending conditions are particularly favorable they may give rise to the formation of a *duct* which can propagate waves with very little attenuation over great distances in a manner similar to the propagation of waves through a waveguide. *Guided propagation* through a duct in the atmosphere can give quite remarkable transmission conditions (figure

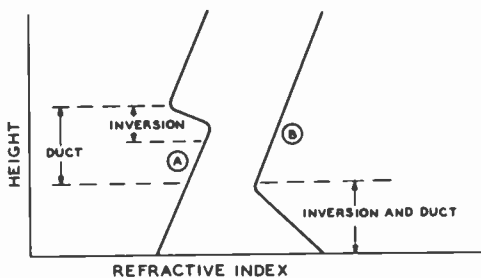

Figure 15

ILLUSTRATING DUCT TYPES

Showing two types of variation in refractive index with height which will give rise to the formation of a duct. An elevated duct is shown at A, and a ground-based duct is shown at B. Such ducts can propagate ground-wave signals far beyond their normal range.

15). However, such ducts usually are formed only on an over-water path. The depth of the duct over the water's surface may be only 20 to 50 feet, or it may be 1000 feet deep or more. Ducts exhibit a low-frequency cutoff characteristic similar to a waveguide. The cutoff frequency is determined by depth of the duct and by the strength of the discontinuity in refractive index at the upper surface of the duct. The lowest frequency that can be propagated by such a duct seldom goes below 50 MHz, and usually will not be greater than 450 MHz even along the Pacific Coast.

Stratospheric Communication by virtue of Reflection stratospheric reflection can be brought about during magnetic storms, aurora borealis displays, and during meteor showers. DX communication during extensive meteor showers is characterized by frequent bursts of great signal strength followed by a rapid decline in strength of the received signal. The motion of the meteor forms an ionized trail of considerable extent which can bring about effective reflection of signals. However, the ionized region persists only for a matter of seconds so that a shower of meteors is necessary before communication becomes possible.

The type of communication which is possible during visible displays of the aurora borealis and during magnetic storms has been called *aurora-type DX*. These conditions reach a maximum somewhat after the sunspot cycle peak, possibly because the spots on the sun are nearer to its equator (and more directly in line with the earth) in the latter part of the cycle. Ionospheric storms generally accompany magnetic storms. The normal layers of the ionosphere may be churned or broken up, making radio transmission over long distances difficult or impossible on high frequencies. Unusual conditions in the ionosphere sometimes modulate vhf waves so that a definite tone or noise modulation is noticed even on transmitters located only a few miles away.

A peculiarity of this type of auroral propagation of vhf signals in the northern hemisphere is that directional antennas usually must be pointed in a northerly direction for best results for transmission or reception, regardless of the direction of the other station

being contacted. Distances out to 700 or 800 miles have been covered during magnetic storms, using 30- and 50-MHz transmitters, with little evidence of any silent zone between the stations communicating with each other. Generally, voice-modulated transmissions are difficult or impossible due to the tone or noise modulation on the signal. Most of the communication of this type has taken place by c.w. or by tone-modulated waves with a keyed carrier.

20-8 Ionospheric Propagation

Propagation of radio waves for communication on frequencies between perhaps 3 and 30 MHz is normally carried out by virtue of *ionospheric reflection* or *refraction*. Under conditions of abnormally high ionization in the ionosphere, communication has been known to have taken place by ionospheric reflection on frequencies higher than 50 MHz.

The ionosphere consists of layers of ionized gas located above the stratosphere, and extending up to possibly 300 miles above

the earth. Thus we see that high-frequency radio waves may travel over short distances in a direct line from the transmitter to the receiver, or they can be radiated upward into the ionosphere to be bent downward in an indirect ray, returning to earth at considerable distance from the transmitter. The wave reaching a receiver via the ionosphere route is termed a *sky wave*. The wave reaching a receiver by traveling in a direct line from the transmitting antenna to the receiving antenna is commonly called a *ground wave*.

The amount of bending at the ionosphere which the sky wave can undergo depends on its frequency, and the amount of *ionization* in the ionosphere, which is in turn dependent on radiation from the sun. The sun increases the density of the ionosphere layers (figure 16) and lowers their effective height. For this reason, the ionosphere acts very differently at different times of day, and at different times of the year.

The higher the frequency of a radio wave, the farther it penetrates the ionosphere, and the less it tends to be bent back toward the earth. The lower the frequency, the more easily the waves are bent, and the less they penetrate the ionosphere. 160-meter and 80-meter signals will usually be bent back to earth even when sent straight up, and may be considered as being *reflected* rather than *refracted*. As the frequency is raised beyond about 5000 kHz (dependent on the critical frequency of the ionosphere at the moment), it is found that waves transmitted at angles higher than a certain critical angle *never return to earth*. Thus, on the higher frequencies, it is necessary to confine radiation to low angles, since the high-angle waves simply penetrate the ionosphere and are lost.

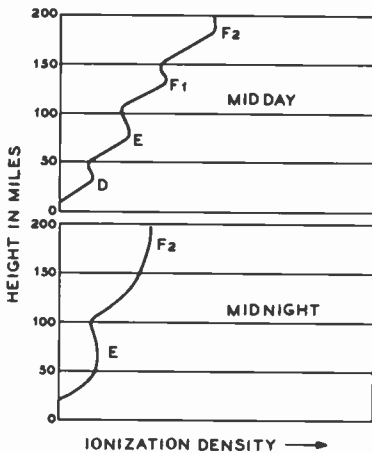

Figure 16

IONIZATION DENSITY IN THE IONOSPHERE

Showing typical ionization density of the ionosphere in midsummer. Note that the *F₁* and *D* layers disappear at night, and that the density of the *E* layer falls to such a low value that it is ineffective.

The *F₂* Layer The higher of the two major reflection regions of the ionosphere is called the *F₂* layer. This layer has a virtual height of approximately 175 miles at night, and in the daytime it splits up into two layers, the upper one being called the *F₂* layer and the lower being called the *F₁* layer. The height of the *F₂* layer during daylight hours is normally about 250 miles on the average and the *F₁* layer often has a height of as low as 140 miles. It is the *F₂* layer which supports all nighttime DX communi-

cation and nearly all daytime DX propagation.

The E Layer Below the F_2 layer is another layer, called the E layer, which is of importance in daytime communication over moderate distances in the frequency range between 3 and 8 MHz. This layer has an almost constant height of about 70 miles. Since the recombination time of the ions at this height is rather short, the E layer disappears almost completely a short time after local sunset.

The D Layer Below the E layer at a height of about 35 miles is an *absorbing* layer, called the D layer, which exists in the middle of the day in the summertime. The layer also exists during midday in winter during periods of high solar activity, but the layer disappears completely at night. It is this layer which causes high absorption of signals in the medium- and high-frequency range during the middle of the day.

Critical Frequency The *critical frequency* of an ionospheric layer is the highest frequency which will be reflected when the wave strikes the layer at vertical incidence. The critical frequency of the most highly ionized layer of the ionosphere may be as low as 2 MHz at night and as high as 12 to 13 MHz in the middle of the day. The critical frequency is directly of interest in that a *skip-distance zone* will exist on all frequencies *greater* than the highest critical frequency at that time. The critical frequency is a measure of the density of ionization of the reflecting layers. The higher the critical frequency the greater the density of ionization.

Maximum Usable Frequency The *maximum usable frequency* or *m. u. f.* is of great importance in long-distance communication since this frequency is the highest that can be used for communication *between any two specified areas*. The m.u.f. is the highest frequency at which a wave projected into space in a certain direction will be returned to earth in a specified region by ionospheric reflection. The m.u.f. is highest at noon or in the early afternoon and is highest in periods of greatest sunspot activity, often going to frequencies higher than 30 MHz. (figure 17).

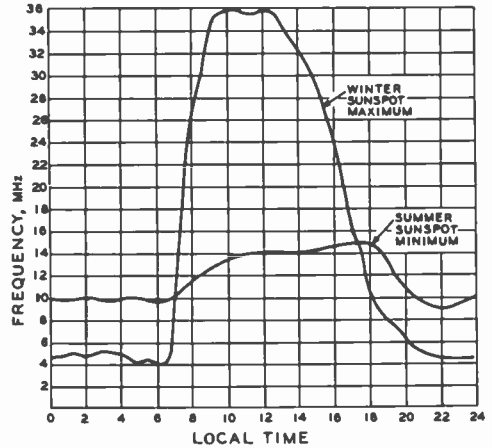

Figure 17

TYPICAL CURVES SHOWING CHANGE IN M.U.F. AT MAXIMUM AND MINIMUM POINTS IN SUNSPOT CYCLE

The m.u.f. often drops to frequencies below 10 MHz in the early morning hours. The high m.u.f. in the middle of the day is brought about by reflection from the F_2 layer. M.u.f. data is published periodically in the magazines devoted to amateur work, and the m.u.f. can be calculated with the aid of *Basic Radio Propagation Predictions*, CRPL-D, published monthly by the Government Printing Office, Washington, D.C.

Absorption and Optimum Working Frequency The *optimum working frequency* for any particular direction and distance is usually about 15 percent less than the m.u.f. for contact with that particular location. The absorption by the ionosphere becomes greater and greater as the operating frequency is progressively lowered below the m.u.f. It is this condition which causes signals to increase tremendously in strength on the 14- and 28-MHz bands just before the signals drop completely out. At the time when the signals are greatest in amplitude the operating frequency is equal to the m.u.f. Then as the signals drop out the m.u.f. has become lower than the operating frequency.

Skip Distance The shortest distance from a transmitting location at which signals reflected from the ionosphere can be

returned to the earth is called the *skip distance*. As was mentioned above under *critical frequency*, there is no skip distance for a frequency below the critical frequency of the most highly ionized layer of the ionosphere at the time of transmission. However, the skip distance is always present on the 14-MHz band and is almost always present on the 3.5 and 7 MHz bands at night. The actual measure of the skip distance is the distance between the point where the ground wave falls to zero and the point where the sky wave begins to return to earth. This distance may vary from 40 to 50 miles on the 3.5-MHz band to thousands of miles on the 28-MHz band.

The Sporadic-E Layer Occasional patches of extremely high ionization density appear at intervals throughout the year at a height approximately equal to that of the E layer. These patches, called the *sporadic-E* layer may be very small or may be up to several hundred miles in extent. The critical frequency of the *sporadic-E* layer may be greater than twice that of the normal ionosphere layers which exist at the same time.

It is this *sporadic-E* condition which provides "short-skip" contacts from 400 to perhaps 1200 miles on the 28-MHz band in the evening. It is also the *sporadic-E* condition which provides the more common type of "band opening" experienced on the 50-MHz band when very loud signals are received from stations from 400 to 1200 miles distant.

Cycles in Ionosphere Activity The ionization density of the ionosphere is determined by the amount of radiation (probably ultraviolet) which is being received from the sun. Consequently, ionosphere activity is a function of the amount of radiation of the proper character being emitted by the sun and is also a function of the relative aspect of the regions in the vicinity of the location under discussion to the sun. There are four main cycles in ionosphere activity. These cycles are: the daily cycle which is brought about by the rotation of the earth, the 27-day cycle which is caused by the rotation of the sun, the seasonal cycle which is caused by the movement of the earth in its orbit, and the

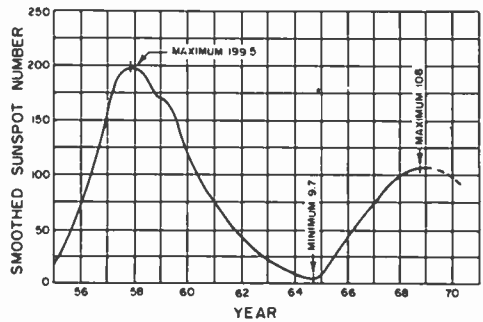

Figure 18

THE YEARLY TREND OF THE SUNSPOT CYCLE. RADIO CONDITIONS IN GENERAL IMPROVED DURING 1966-1969 AS THE CYCLE INCREASED

11-year cycle which is a cycle in sunspot activity. The effects of these cycles are superimposed insofar as ionosphere activity is concerned. Also, the cycles are subject to short term variations as a result of magnetic storms and similar terrestrial disturbances.

The most recent minimum of the 11-year sunspot cycle occurred during the winter of 1964-1965, and we are currently moving along the slope of a new cycle, the maximum of which probably occurred during 1969. The current cycle is pictured in figure 18.

Fading The lower the angle of radiation of the wave, with respect to the horizon, the farther away will the wave return to earth, and the greater the skip distance. The wave can be reflected back up into the ionosphere by the earth, and then be reflected back down again, causing a second skip distance area. The drawing of figure 19 shows the multiple reflections possible. When the receiver receives signals which have traveled over more than one path between transmitter and receiver, the signal impulses will not all arrive at the same instant, since they do not all travel the same distance. When two or more signals arrive in the same phase at the receiving antenna, the resulting signal in the receiver will be quite strong. On the other hand, if the signals arrive 180° out of phase, so they tend to cancel each other, the received signal will drop—perhaps

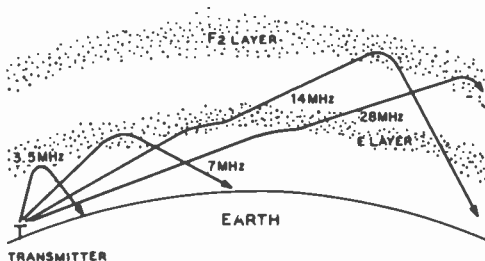

Figure 19

IONOSPHERE-REFLECTION WAVE PATHS

Showing typical ionosphere-reflection wave paths during daylight hours when ionization density is such that frequencies as high as 28 MHz will be returned to earth. The distance between ground-wave range and that range where the ionosphere-reflected wave of a specific frequency first will be returned to earth is called the skip distance.

to zero if perfect cancellation occurs. This explains why high-frequency signals are subject to fading.

Fading can be greatly reduced on the high frequencies by using a transmitting antenna with sharp vertical directivity, thus cutting down the number of possible paths of signal arrival. A receiving antenna with similar characteristics (sharp vertical directivity) will further reduce fading. It is desirable, when using antennas with sharp vertical directivity, to use the lowest vertical angle consistent with good signal strength for the frequency used.

Scattered Reflections Scattered reflections are random, diffused, substantially isotropic reflections which are partly responsible for reception within the skip zone, and for reception of signals from directions off the great circle path.

In a heavy fog or mist, it is difficult to see the road at night because of the bright glare caused by scattered reflection of the headlight beam by the minute droplets. In fact, the road directly to the side of the car will be weakly illuminated under these conditions, whereas it would not on a clear night (assuming flat, open country). This is a good example of propagation of waves by scattered reflections into a zone which otherwise would not be illuminated.

Scattering occurs in the ionosphere at all times, because of irregularities in the medium (which result in "patches" corresponding to the water droplets) and because of random-phase radiation due to the collision or recombination of free electrons. However, the nature of the scattering varies widely with time, in a random fashion. Scattering is particularly prevalent in the *E* region, but scattered reflections may occur at any height, even well out beyond the virtual height of the *F*₂ layer.

There is no "critical frequency" or "lowest perforating frequency" involved in the scattering mechanism, though the intensity of the scattered reflections due to typical scattering in the *E* region of the ionosphere decreases with frequency.

When the received signal is due primarily to scattered reflections, as is the case in the skip zone or where the great circle path does not provide a direct sky wave (due to low critical or perforation frequency, or to an ionosphere storm) very bad distortion will be evident, particularly a "flutter fade" and a characteristic "hollow" or echo effect.

Deviations from a great circle path are especially noticeable in the case of great circle paths which cross or pass near the auroral zones, because in such cases there often is complete or nearly complete absorption of the direct sky wave, leaving off-path scattered reflections the only mechanism of propagation. Under such conditions the predominant wave will appear to arrive from a direction closer to the equator, and the signal will be noticeably, if not considerably, weaker than a direct sky wave which is received under favorable conditions.

Irregular reflection of radio waves from "scattering patches" is divided into two categories: *short scatter* and *long scatter*.

Short scatter is the scattering that occurs when a radio wave first reaches the scattering patches or media. Ordinarily it is of no particular benefit, as in most cases it only serves to fill in the inner portion of the skip zone with a weak, distorted signal.

Long scatter occurs when a wave has been refracted from the *F*₂ layer and strikes scattering patches or media on the way down. When the skip distance exceeds several hundred miles, long scatter is primarily responsible for reception within the skip zone, par-

ticularly the outer portion of the skip zone. Distortion is much less severe than in the case of short scatter, and while the signal is likewise weak, it sometimes can be utilized for satisfactory communication.

During a severe ionosphere disturbance in the north auroral zone, it sometimes is possible to maintain communication between the Eastern United States and Northern Europe by the following mechanism: That portion of the energy which is radiated in the direction of the great circle path is completely absorbed on reaching the auroral zone. However, the portion of the wave leaving the United States in a *southeasterly* direction is refracted downward from the F_2 layer and encounters scattering patches or media on its downward trip at a distance of approximately 2000 miles from the transmitter. There it is reflected by "long scatter" in all directions, this scattering region acting like an isotropic radiator fed with a very small fraction of the original transmitter power. The great circle path from this southerly point to northern Europe does not encounter unfavorable ionosphere conditions, and the wave is propagated the rest of the trip as though it had been radiated from the scattering region.

Another type of scatter is produced when a sky wave strikes certain areas of the earth. On striking a comparatively smooth surface such as the sea, there is little scattering, the wave being shot up again by what could be considered specular, or mirror, reflection. But on striking a mountain range, for instance, the reradiation or reflected energy is scattered, some of it being directed back toward the transmitter, thus providing another mechanism for producing a signal within the skip zone.

Meteors and "Bursts" When a meteor strikes the earth's atmosphere, a cylindrical region of free electrons is formed at approximately the height of the E layer. This slender ionized column is quite long, and when first formed is sufficiently dense to reflect radio waves back to earth most readily, *including vhf waves which are not ordinarily returned by the F_2 layer.*

The effect of a single meteor, or normal size, shows up as a sudden "burst" of signal of short duration at points not ordinarily

reached by the transmitter. After a period of from 10 to 40 seconds, recombination and diffusion have progressed to the point where the effect of a *single* fairly large meteor is not perceptible. However, there are many *small* meteors impinging on earth's atmosphere every minute, and the *aggregate* effect of their transient ionized trails, including the small amount of residual ionization that exists for several minutes after the original flash but is too weak and dispersed to prolong a "burst," is believed to contribute to the existence of the *nighttime-E* layer, and perhaps also to *sporadic-E* patches.

While there are many of these very small meteors striking the earth's atmosphere every minute, meteors of normal size (sufficiently large to produce individual "bursts") do not strike nearly so frequently except during some of the comparatively rare meteor "showers." During one of these displays a "quivering" ionized layer is produced which is intense enough to return signals in the lower vhf range with good strength, but with a type of "flutter" distortion which is characteristic of this type of propagation.

20-9 Transmission Lines

For many reasons it is desirable to place an antenna or radiating system as high and in the clear as is physically possible, utilizing some form of nonradiating transmission line to carry energy with as little loss as possible from the transmitter to the radiating antenna, and conversely from the antenna to the receiver.

There are many different types of transmission lines and, generally speaking, practically any type of transmission line or feeder system may be used with any type of antenna. However, mechanical or electrical considerations often make one type of transmission line better adapted for use to feed a particular type of antenna than any other type.

Transmission lines for carrying r-f energy are of two general types: *nonresonant* and *resonant*. A nonresonant transmission line is one on which a successful effort has been made to eliminate reflections from the termination (the antenna in the transmitting case and the receiver for a receiving antenna) and hence one on which standing waves

do not exist or are relatively small in magnitude. A resonant line, on the other hand, is a transmission line on which standing waves of appreciable magnitude do appear, either through inability to match the characteristic impedance of the line to the termination or through intentional design.

The principal types of transmission line in use or available at this time include the open-wire line (two-wire and four-wire types), two-wire solid-dielectric line (*twin-lead* and similar ribbon or tubular types), two-wire polyethylene-filled shielded line, coaxial line of the solid-dielectric, beaded, stub-supported, or pressurized type, rectangular and cylindrical waveguide, and the single-wire feeder operated against ground. The significant characteristics of the more popular types of transmission line available at this time are given in the chart of figure 21.

20-10 Nonresonant Transmission Lines

A nonresonant or untuned transmission line is a line with negligible standing waves. Hence, a nonresonant line is a line carrying r-f power only in one direction—from the source of energy to the load.

Physically, the line itself should be *identical throughout its length*. There will be a smooth distribution of voltage and current throughout its length, both tapering off very slightly towards the load end of the line as a result of line losses. The attenuation (loss) in certain types of untuned lines can be kept very low for line lengths up to several thousand feet. In other types, particularly where the dielectric is not air (such as in the twisted-pair line), the losses may become excessive at the higher frequencies, unless the line is relatively short.

Transmission-Line Impedance All transmission lines have distributed inductance, capacitance, and resistance. Neglecting the resistance, as it is of minor importance in short lines, it is found that the *inductance and capacitance per unit length* determine the characteristic or surge impedance of the line. Thus, the surge impedance depends upon the nature and spacing of the conductors, and the dielectric separating them.

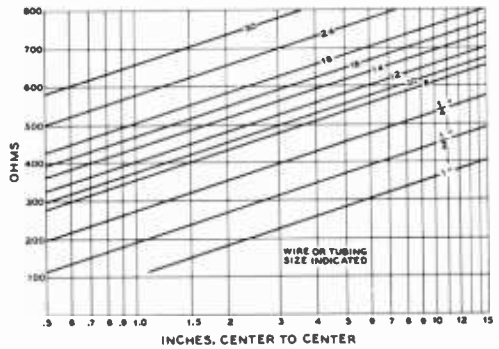

Figure 20

CHARACTERISTIC IMPEDANCE OF TYPICAL TWO-WIRE OPEN LINES

Speaking in electrical terms, the characteristic impedance of a transmission line is simply the ratio of the voltage across the line to the current which is flowing, the same as is the case with a simple resistor: $Z_0 = E/I$. Also, in a substantially lossless line (one whose attenuation per wavelength is small) the energy stored in the line will be equally divided between the electric field and the magnetic field which serve to propagate the energy along the line. Hence the characteristic impedance of a line may be expressed as:

$$Z_0 = \sqrt{L/C}$$

Two-Wire Open Line A two-wire transmission system is easy to construct. Its surge impedance can be calculated quite easily, and when properly adjusted and balanced to ground, with a conductor spacing which is negligible in terms of the wavelength of the signal carried, undesirable feeder radiation is minimized; the current flow in the adjacent wires is in opposite directions, and the magnetic fields of the two wires are in opposition to each other. When a two-wire line is terminated with the equivalent of a pure resistance equal to the characteristic impedance of the line, the line becomes a nonresonant line.

Expressed in physical terms, the characteristic impedance of a two-wire open line is equal to:

$$Z_0 = 276 \log_{10} \frac{2S}{d}$$

CHARACTERISTICS OF COMMON TRANSMISSION LINES

	Attenuation db/100 feet VSWR = 1.0			Velo- city factor V	pf per ft.	REMARKS
	30 MHz	100 MHz	300 MHz			
Open wire line, No. 12 copper.	0.15	0.3	0.8	0.96-0.99	—	Based on 4" spacing below 50 MHz; 2" spacing above 50 MHz. Radiation losses included. Clean, low-loss ceramic insulation assumed. Radiation high above 150 MHz.
Ribbon line, rec. type, 300 ohms. (7/28 conductors)	0.86	2.2	5.3	0.82*	6*	For clean dry line, wet weather performance rather poor, best line is slightly convex. Avoid line that has concave dielectric. Suitable for low-power transmitting applications. Losses increase as line weathers. Handles 400 watts at 30 MHz if SWR is low.
Tubular "twin-lead" rec. type, 300 ohms, 5/16" O.D., (Amphenol type 14-271)	—	—	—	—	—	Characteristics similar to receiving-type ribbon line except for much better wet-weather performance.
Ribbon line, trans. type, 300 ohms.	—	—	—	—	—	Characteristics vary somewhat with manufacturer, but approximate those of receiving-type ribbon except for greater power-handling capability and slightly better wet weather performance.
Tubular "twin-lead" trans. type, 7/16 O.D. (Amphenol 14-076)	0.85	2.3	5.4	0.79	6.1	For use where receiving-type tubular "twin-lead" does not have sufficient power-handling capability. Will handle 1 kw at 30 MHz if SWR is low.
Ribbon line, receive type, 150 ohms.	1.1	2.7	6.0	0.77*	10*	Useful for quarter-wave matching sections. No longer widely used as a line.
Ribbon line, receive type, 75 ohms.	2.0	5.0	11	0.68*	19*	Useful mainly in the hf range because of excessive losses at vnt and uhf. Less affected by weather than 300-ohm ribbon.
Ribbon line, trans. type, 75 ohms.	1.5	3.9	8.0	0.71*	18*	Very satisfactory for transmitting applications below 30 MHz at powers up to 1 kw. Not significantly affected by wet weather.
RG-8/U coax (52 ohms)	1.0	2.1	4.2	0.66	29.5	Will handle 2 kw at 30 MHz if SWR is low. 0.4" O.D. 7/21 conductor.
RG-11/U coax (75 ohms)	0.94	1.9	3.8	0.66	20.5	Will handle 1.4 kw at 30 MHz if SWR is low. 0.4" O.D. 7/26 conductor.
RG-17/U coax (52 ohms)	0.38	0.85	1.8	0.66	29.5	Will handle 7.8 kw at 30 MHz if SWR is low. 0.87" O.D. 0.19" dia. conductor.
RG-58/U coax (53 ohms)	1.95	4.1	8.0	0.66	28.5	Will handle 430 watts at 30 MHz if SWR is low. 0.2" O.D. No. 20 conductor.
RG-59/U coax (73 ohms)	1.9	3.8	7.0	0.66	21	Will handle 680 watts at 30 MHz if SWR is low. 0.24" O.D. No. 22 conductor.
TV-59 coax (72 ohms)	2.0	4.0	7.0	0.66	22	"Commercial" version of RG-59/U for less exacting applications. Less expensive.
RG-22/U shielded pair (95 ohms)	1.7	3.0	5.5	0.66	16	For shielded, balanced-to-ground applications. Very low noise pickup. 0.4" O.D.
K-111 shielded pair (300 ohms)	2.0	3.5	6.1	—	4	Designed for TV lead-in in noisy locations. Losses higher than regular 300-ohm ribbon, but do not increase as much from weathering.

* Approximate. Exact figure varies slightly with manufacturer.

FIGURE 21

Older type coaxial lines have a useful life of three to six years after which the cable attenuation gradually rises, especially under conditions of heat. Newer cables (designated by the suffix A: RG-8A/U for example) have useful life up to twelve years or so. The 52-ohm series cables have been recently replaced with 50-ohm cables, RG-8A/U now being designated RG-213/U. Long-life versions of the RG-58 family are: RG-58B/U (53.5-ohm) and RG-58C/U (50-ohm).

where,

S is the exact distance between wire centers in some convenient unit of measurement,

d is the diameter of the wire measured in the same units as the wire spacing, S.

Since $\frac{2S}{d}$ expresses a ratio only, the units of measurement may be centimeters, millimeters, or inches. This makes no difference in the answer, so long as the substituted values for S and d are in the same units.

The equation is accurate so long as the wire spacing is relatively large as compared to the wire diameter.

Surge impedance values of less than 200 ohms are seldom used in the open-type two-wire line, and, even at this rather high value of Z_0 , the wire spacing S is uncomfortably close, being only 2.7 times the wire diameter.

Figure 20 gives in graphical form the surge impedance of practical two-wire lines. The chart is self-explanatory, and is sufficiently accurate for practical purposes.

Ribbon and Tubular Transmission Line Instead of using spacer insulators placed periodically along the transmission line it is possible to mold the line conductors into a ribbon or tube of flexible low-loss dielectric material. Such line, with polyethylene dielectric, is used in enormous quantities as the lead-in transmission line for f-m and TV receivers. The line is available from several manufacturers in the ribbon and tubular configuration, with characteristic impedance values from 75 to 300 ohms. Receiving types, and transmitting types of power levels up to one kilowatt in the hf range, are listed with their pertinent characteristics, in the table of figure 21.

Coaxial Line Several types of coaxial cable have come into wide use for feeding power to an antenna system. A cross-sectional view of a coaxial cable (sometimes called concentric cable or line) is shown in figure 22.

As in the parallel-wire line, the power lost in a properly terminated coaxial line is the sum of the effective resistance losses along the length of the cable and the dielectric losses between the two conductors.

Of the two losses, the effective resistance loss is the greater; since it is largely due to the skin effect, the line loss (all other conditions the same) will increase directly as the square root of the frequency.

Figure 22 shows that, instead of having two conductors running side by side, one of the conductors is placed *inside* the other. Since the outside conductor completely shields the inner one, no radiation takes place. The conductors may both be tubes, one within the other; the line may consist of a solid wire within a tube, or it may consist of

a stranded or solid inner conductor with the outer conductor made up of one or two wraps of copper shielding braid.

In the type of cable most popular for military and noncommercial use the inner conductor consists of a heavy stranded wire, the outer conductor consists of a braid of copper wire, and the inner conductor is supported within the outer by means of a semisolid dielectric of exceedingly low-loss characteristics called polyethylene. The Army-Navy designation on one size of this cable suitable for power levels up to one kilowatt at frequencies as high as 30 MHz is RG-8/u. The outside diameter of this type of cable is approximately one-half inch. The characteristic impedance of this cable type is 52 ohms, but other similar types of greater and smaller power-handling capacity are available in impedances of 52, 75, and 95 ohms.

When using solid dielectric coaxial cable it is necessary that precautions be taken to ensure that moisture cannot enter the line. If the better grade of connectors manufactured for the line are employed as terminations, this condition is automatically satisfied. If connectors are not used, it is necessary that some type of moisture-proof sealing com-

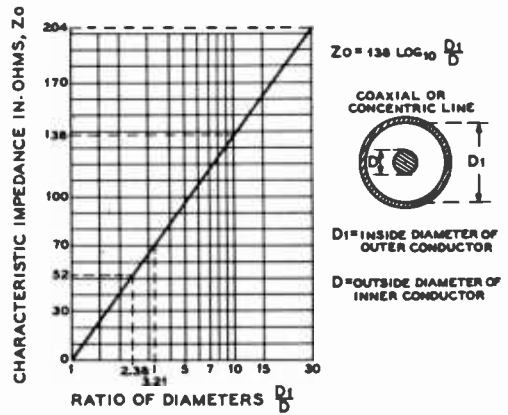

Figure 22

CHARACTERISTIC IMPEDANCE OF AIR-FILLED COAXIAL LINES

If the filling of the line is a dielectric material other than air, the characteristic impedance of the line will be reduced by a factor proportional to the square-root of the dielectric constant of the material used as a dielectric within the line.

pound be applied to the end of the cable where it will be exposed to the weather.

Nearby metallic objects cause no loss, and coaxial cable may be run up air ducts or elevator shafts, inside walls, or through metal conduit. Insulation troubles can be forgotten. The coaxial cable may be buried in the ground or suspended above ground.

Standing Waves Standing waves on a transmission line *always* are the result of the reflection of energy. The only significant reflection which takes place in a normal installation is that at the load end of the line. But reflection can take place from discontinuities in the line, such as caused by insulators, bends, or metallic objects adjacent to an unshielded line.

When a uniform transmission line is terminated in an impedance equal to its surge impedance, reflection of energy does not occur, and no standing waves are present.

Thus, for proper operation of an untuned line (with standing waves eliminated), some form of impedance-matching arrangement must be used between the transmission line and the antenna, so that the radiation resistance of the antenna is reflected back into the line as a nonreactive impedance equal to the line impedance.

The termination at the antenna end is the only critical characteristic about the untuned line fed by a transmitter. It is the reflection from the antenna end which starts waves moving back toward the transmitter end. When waves moving in both directions along a conductor meet, standing waves are set up.

Semiresonant Parallel-Wire Lines A well-constructed open-wire line has acceptably low losses when its length is less than about two wavelengths even when the voltage standing-wave ratio is as high as 10 to 1. A transmission line constructed of ribbon or tubular line, however, should have the standing-wave ratio kept down to not more than about 3 to 1 both to reduce power loss and because the energy dissipation on the line will be localized, causing overheating of the line at the points of maximum current.

Because moderate standing waves can be tolerated on open-wire lines without much loss, a standing-wave ratio of 2/1 or 3/1 is considered acceptable with this type of line,

even when used in an untuned system. Strictly speaking, a line is untuned, or non-resonant, only when it is perfectly *flat*, with a standing-wave ratio of 1 (no standing waves). However, some mismatch can be tolerated with open-wire untuned lines, so long as the reactance is not objectionable, or is eliminated by cutting the line to approximately resonant length.

20-11 Tuned or Resonant Lines

If a transmission line is terminated in its *characteristic surge impedance*, there will be no reflection at the end of the line, and the current and voltage distribution will be uniform along the line. If the end of the line is either open-circuited or short-circuited, the reflection at the end of the line will be 100 percent, and *standing waves* of very great amplitude will appear on the line. There will still be practically no radiation from the line if it is closely spaced, but voltage nodes will be found every half wavelength, the voltage loops corresponding to current nodes (figure 23).

If the line is terminated in some value of resistance other than the characteristic surge impedance, there will be some reflection, the amount being determined by the amount of mismatch. With reflection, there will be standing waves (excursions of current and voltage) along the line, though not to the same extent as with an open-circuited or short-circuited line. The current and voltage loops will occur at the same *points* along the line as with the open- or short-circuited line, and as the terminating impedance is made to approach the characteristic impedance of the line, the current and voltage along the line will become more uniform. The foregoing assumes, of course, a purely resistive (non-reactive) load. If the load is reactive, standing waves also will be formed. But with a reactive load the nodes will occur at different locations from the node locations encountered with improper resistive termination.

A well built 500- to 600-ohm transmission line may be used as a resonant feeder for lengths up to several hundred feet with very low loss, so long as the amplitude of the standing waves (ratio of maximum to minimum voltage along the line) is *not too great*.

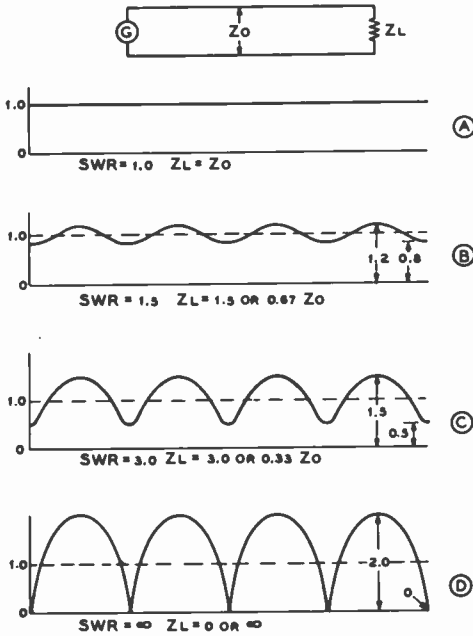

Figure 23

STANDING WAVES ON A TRANSMISSION LINE

As shown at A, the voltage and current are constant on a transmission line which is terminated in its characteristic impedance, assuming that losses are small enough so that they may be neglected. B shows the variation in current or in voltage on a line terminated in a load with a reflection coefficient of 0.2 so that a standing-wave ratio of 1.5 to 1 is set up. At C the reflection coefficient has been increased to 0.5, with the formation of a 3-to-1 standing-wave ratio on the line. At D the line has been terminated in a load which has a reflection coefficient of 1.0 (short, open circuit, or a pure reactance) so that all the energy is reflected with the formation of an infinite standing-wave ratio.

The amplitude, in turn, depends on the mismatch at the line termination. A line of No. 12 wire, spaced 6 inches with good ceramic or plastic spreaders, has a surge impedance of approximately 600 ohms, and makes an excellent tuned feeder for feeding anything between 60 and 6000 ohms (at frequencies below 30 MHz). If used to feed a load of higher or lower impedance than this, the standing waves become great enough in amplitude that some loss will occur unless the feeder is kept short. At frequencies above 30 MHz, the spacing becomes an appreciable fraction of a wavelength, and radiation from

the line no longer is negligible. Hence, coaxial line or close-spaced parallel-wire line is recommended for vhf work.

If a transmission line is not perfectly matched, it should be made *resonant*, even though the amplitude of the standing waves (voltage variation) is not particularly great. This prevents reactance from being coupled into the final amplifier. A feed system having moderate standing waves may be made to present a nonreactive load to the amplifier either by tuning or by pruning the feeders to approximate resonance.

Usually it is preferable with tuned feeders to have a current loop (voltage minimum) at the transmitter end of the line. This means that when voltage-feeding an antenna, the tuned feeders should be made an odd number of quarter wavelengths long, and when current-feeding an antenna, the feeders should be made an even number of quarter wavelengths long. Actually, the feeders are made about 10 percent of a quarter wave longer than the calculated value (the value given in the tables) when they are to be series tuned to resonance by means of a capacitor, instead of being trimmed and pruned to resonance.

When tuned feeders are used to feed an antenna on more than one band, it is necessary to compromise and make provision for both series and parallel tuning, inasmuch as it is impossible to cut a feeder to a length that will be optimum for several bands. If a voltage loop appears at the transmitter end of the line on certain bands, parallel tuning of the feeders will be required in order to get a transfer of energy. It is impossible to transfer energy by inductive coupling unless current is flowing. This is effected as a voltage loop by the presence of the resonant tank circuit formed by parallel tuning of the antenna coil.

20-12 Line Discontinuities

In the previous discussion we have assumed a transmission line which was uniform throughout its length. In actual practice, this is usually not the case.

Whenever there is any sudden change in the characteristic impedance of the line, partial reflection will occur at the point of discontinuity. Some of the energy will be

transmitted and some reflected, which is essentially the same as having some of the energy absorbed and some reflected in so far as the effect on the line from the generator to that point is concerned. The discontinuity can be ascribed a reflection coefficient just as in the case of an unmatched load.

In a simple case, such as a finite length of uniform line having a characteristic impedance of 500 ohms feeding into an infinite length of uniform line having a characteristic impedance of 100 ohms, the behavior is easily predicted. The infinite 100-ohm line will have no standing waves and will accept the same power from the 500-ohm line as would a 100-ohm resistor, and the rest of the energy will be reflected at the discontinuity to produce standing waves from there back to the generator. However, in the case of a complex discontinuity placed at an odd distance down a line terminated in a complex impedance, the picture becomes complicated, especially when the discontinuity is neither sudden nor gradual, but intermediate between the two. This is the usual case with amateur lines that must be erected around buildings and trees.

In any case, when a discontinuity exists somewhere on a line and is not a smooth, gradual change embracing several wavelengths, it is not possible to avoid standing waves throughout the entire length of the line. If the discontinuity is sharp enough and is great enough to be significant, standing waves must exist on one side of the discontinuity, and may exist on both sides in many cases.

20-13 A Broadband 50-Ohm Balun

Many triband high-frequency beam antennas feature a balanced input system having a 50-ohm feed point. In order to reduce line discontinuities and to provide a better match between the antenna and an unbalanced transmission line, a *balun* (balance to unbalance) r-f transformer should be used. Shown in figure 24 is a broadband balun that is effective over the range of 6 to 30 MHz. The balun is an inexpensive coil made of a length of coaxial cable and is designed to be installed directly at the terminals of the antenna.

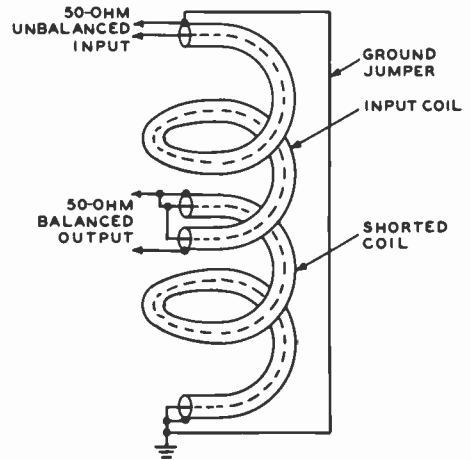

Figure 24

AN EFFECTIVE BROADBAND BALUN FOR MULTIBAND BEAMS

This lumped-constant balun is self-resonant near the center design frequency which, in this case, is about 15 MHz. The balun coil is made of a 16'8"-length of 50-ohm coaxial line (RG-213/U or RG-8/AU) closewound into a coil of 9 turns having an inside diameter of 6¾ inches. At one end of the coil the inner and outer conductors of the line are shorted together and grounded to the common ground point of the antenna assembly. The unbalanced coaxial transmission line is attached to the other end of the coil and a ground jumper is run between the outer ends of the braided conductor. At the center of the winding, the outer braid of the coaxial line is severed for a distance of about one inch, and a connection is made to the inner conductor at this point. In addition, the inner conductor is jumpered to the outer braid of the *shorted* coil section. A second connection is made to the outer braid of the input coil section, as shown in the illustration. These connections are wrapped with vinyl tape and coated with an aerosol plastic spray to protect the joint against the weather. A coaxial plug may be attached to the input terminals of the balun. Connection to the balanced antenna element is made at the center connections of the balun coil, using low-impedance copper straps about ¼ inch wide.

Antennas and Antenna Matching

Antennas for the lower-frequency portion of the high-frequency spectrum (from 1.8 to 7.0 MHz), and temporary or limited-use antennas for the upper portion of the high-frequency range, usually are of a relatively simple type in which directivity is not a prime consideration. Also, it often is desirable, in amateur work, that a single antenna system be capable of operation at least on the 3.5- and 7.0-MHz ranges, and preferably on other frequency ranges. Consequently, the first portion of this chapter will be devoted to a discussion of such antenna systems. The latter portion of the chapter is devoted to the general problem of matching the antenna transmission line to antenna systems of the fixed type. Matching the antenna transmission line to the rotatable directive array is discussed in Chapter Twenty-four.

21-1 End-Fed Half-Wave Horizontal Antennas

The half-wave horizontal dipole is the most common and the most practical antenna for the 3.5- and 7-MHz amateur bands. The form of the dipole, and the manner in which it is fed are capable of a large number of variations. Figure 2 shows a number of practical forms of the simple dipole antenna along with methods of feed.

Usually a high-frequency doublet is mounted as high and as much in the clear as possible, for obvious reasons. However,

it is sometimes justifiable to bring part of the radiation system directly to the transmitter, feeding the antenna without benefit of a transmission line. This is permissible when (1) there is insufficient room to erect a 75- or 80-meter horizontal dipole and feed line, (2) when a long wire is also to be operated on one of the higher-frequency bands on a harmonic. In either case, it is usually possible to get the main portion of the antenna in the clear because of its length. This means that the power lost by bringing the antenna directly to the transmitter is relatively small.

End-Fed Antennas The end-fed antenna has no form of transmission line to couple it to the transmitter, but brings the radiating portion of the antenna right down to the transmitter, where some form of coupling system is used to transfer energy to the antenna.

Figure 1 shows two common methods of feeding the *Fuchs antenna* or *end-fed Hertz*. Some harmonic-attenuating provision (in addition to the usual low-pass TVI filter) must be included in the coupling system, since an end-fed antenna itself offers no discrimination against harmonics, either odd or even.

The end-fed Hertz antenna has rather high losses unless at least three-quarters of the radiator can be placed outside the operating room and in the clear. As there is r-f

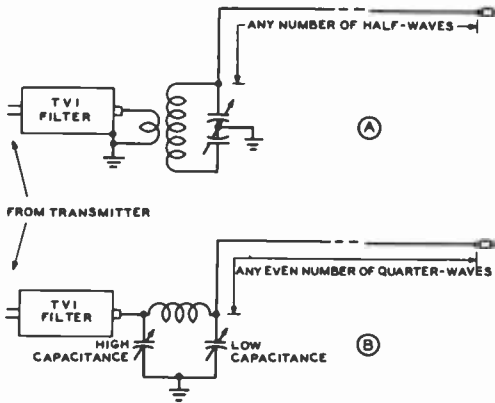

Figure 1

THE END-FED HERTZ ANTENNA

Showing the manner in which an end-fed Hertz antenna may be fed through a low-impedance line and low-pass filter by using a resonant tank circuit as at A, or through the use of a reverse-connected pi-network as at B.

voltage at the point where the antenna enters the operating room, the insulation at that point should be several times as effective as the insulation commonly used with low-voltage feeder systems. This antenna can be operated on all of its higher harmonics with good efficiency, and can be operated at half frequency against ground as a quarter-wave Marconi.

The Zepp Antenna System The *zeppelin*, or *zepp antenna system*, illustrated in figure 2A is very convenient when it is desired to operate a single radiating wire on a number of harmonically related frequencies.

The zepp antenna system is easy to tune, and can be used on several bands by merely retuning the feeders. As the radiating portion of the zepp antenna system must always be some multiple of a half wave long, there is always high voltage present at the point where the live zepp feeder attaches to the end of the radiating portion of the antenna. Thus, this type of zepp antenna system is *voltage-fed*.

Stub-Fed Zepp-Type Radiator Figure 2C shows a modification of the zepp-type antenna system to allow the

use of a nonresonant transmission line between the radiating portion of the antenna and the transmitter. The *zepp* portion of the antenna is resonated as a quarter-wave stub and the nonresonant feeders are connected to the stub at a point where standing waves on the feeder are minimized. The procedure for making these adjustments is described in detail in Section 21-8. This type of antenna system is quite satisfactory when it is physically necessary to end-feed the antenna, and where it is necessary also to use nonresonant feeders between the transmitter and the radiating system.

21-2 Center-Fed Half-Wave Horizontal Antennas

A center-fed half-wave antenna system is usually to be desired over an end-fed system since the center-fed system is inherently balanced to ground and is therefore less likely to be troubled by feeder radiation. A number of center-fed systems are illustrated in figure 2.

The Tuned Doublet The current-fed doublet with spaced feeders, sometimes called a *center-fed zepp*, is an inherently balanced system if the two legs of the radiator are electrically equal. This fact holds true regardless of the frequency, or of the harmonic, on which the system is operated. The system can successfully be operated over a wide range of frequencies if the system as a whole (both tuned feeders and the center-fed flat top) can be resonated to the operating frequency. It is usually possible to tune such an antenna system to resonance with the aid of a tapped coil and a tuning capacitor that can optionally be placed either in series with the antenna coil or in parallel with it. A series-tuning capacitor can be placed in series with one feeder leg without unbalancing the system.

The tuned-doublet antenna is shown in figure 2D. The antenna is a current-fed system when the radiating wire is a half wave long electrically, or when the system is operated on its odd harmonics, but becomes a voltage-fed radiator when operated on its even harmonics.

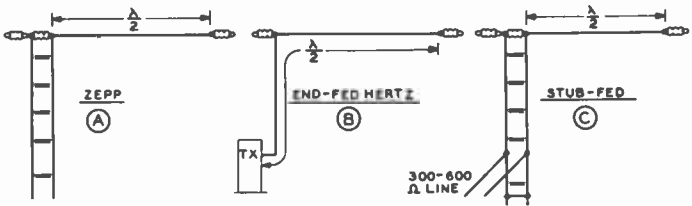

END-FED TYPES

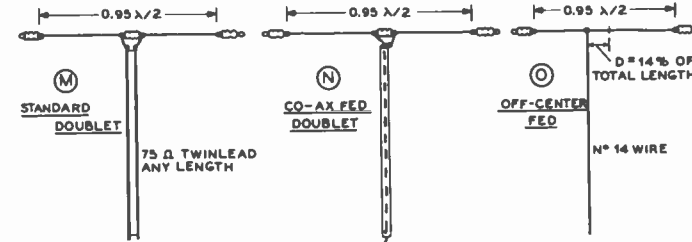
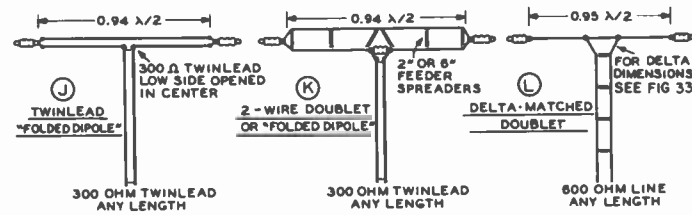
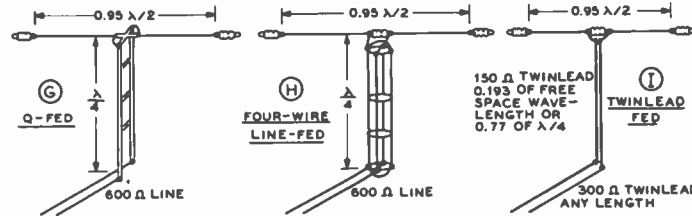
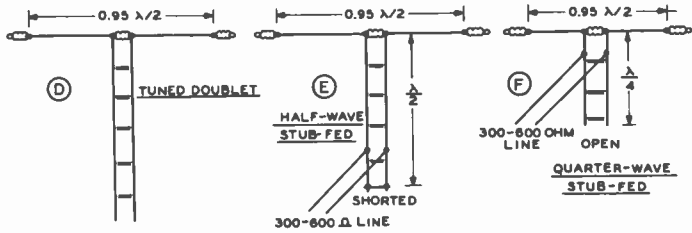

CENTER-FED TYPES

Figure 2
FEED SYSTEMS FOR A HALF-WAVE DIPOLE ANTENNA

The half-wave dipole antenna may be either center- or end-fed, as discussed in the text. For the hf region (below 30 MHz), the length of a simple dipole is computed by: length (feet) = $468/f$, with f in MHz. For the folded dipole, length is computed by: length (feet) = $462/f$, with f in MHz. Above 30 MHz, the length of the dipole is affected to an important degree by the diameter of the element and the method of supporting the dipole (see VHF and UHF Antennas and Radiation, Propagation, and Lines chapters).

The antenna has a different radiation pattern when operated on its harmonics, as would be expected. The arrangement used on the second harmonic is better known as the *Franklin collinear array* and is described in Chapter Twenty-two. The pattern is similar to a half-wave dipole except that it is sharper in the broadside direction. On higher harmonics of operation there will be multiple lobes of radiation from the system.

Figures 2E and 2F show alternative arrangements for using an untuned transmission line between the transmitter and the tuned-doublet radiator. In figure 2E a half-wave shorted line is used to resonate the radiating system, while in figure 2F a quarter-wave open line is utilized. The adjustment of quarter-wave and half-wave stubs is discussed in Section 21-8.

Doublets with Quarter-Wave Transformers The average value of feed impedance for a center-fed half-wave doublet is 75 ohms. The actual value varies with height and is shown in Chapter Twenty. Other methods of matching this rather low value of impedance to a medium-impedance transmission line are shown in G, H, and I of figure 2. Each of these three systems uses a quarter-wave transformer to accomplish the impedance transformation. The only difference between the three systems lies in the type of transmission line used in the quarter-wave transformer. G shows the *Q-match system* whereby a line made up of 1/2-inch dural tubing is used for the low-impedance linear transformer. A line made up in this manner is frequently called a set of *Q bars*. Illustration H shows the use of a four-wire line as the linear transformer, and I shows the use of a piece of 150-ohm twin-lead electrically 1/4-wave in length as the transformer between the center of the dipole and a piece of 300-ohm twin-lead. In any case the impedance of the quarter-wave transformer will be of the order of 150 to 200 ohms. The use of sections of transmission line as linear transformers is discussed in detail in Section 21-8.

Multiwire Doublets An alternative method for increasing the feed-point impedance of a dipole so that a medium-impedance transmission line may be used is shown in figures 2J and 2K. This system

utilizes more than one wire in parallel for the radiating element, but only one of the wires is broken for attachment of the feeder. The most common arrangement uses two wires in the flat top of the antenna so that an impedance multiplication of four is obtained.

The antenna shown in figure 2J is the so-called *twin-lead folded dipole* which is a commonly used antenna system on the medium-frequency amateur bands. In this arrangement both the antenna and the transmission line to the transmitter are constructed of 300-ohm twin-lead. The flat top of the antenna is made slightly less than the conventional length ($462/F_{\text{MHz}}$ instead of $468/F_{\text{MHz}}$ for a single-wire flat top) and the two ends of the twin-lead are joined together at each end. The center of one of the conductors of the twin-lead flat top is broken and the two ends of the twin-lead feeder are spliced into the flat-top leads. As a protection against moisture, pieces of flat polyethylene taken from another piece of 300-ohm twin-lead may be molded over the joint between conductors with the aid of a soldering iron.

Better bandwidth characteristics can be obtained with a folded dipole made of ribbon line if the two conductors of the ribbon line are shorted a distance of 0.82 (the velocity factor of ribbon line) of a free-space quarter-wave-length from the center or feed point. This procedure is illustrated in figure 3A. An alternative arrangement for a twin-lead folded dipole is illustrated in figure 3B. This type of half-wave antenna system is convenient for use on the 3.5-MHz band when the 116- to 132-foot distance required for a full half-wave is not quite available in a straight line, since the single-wire end pieces may be bent away or downward from the direction of the main section of the antenna.

Figure 2K shows the basic type of two-wire doublet or *folded dipole* wherein the radiating section of the system is made up of standard antenna wire spaced by means of feeder spreaders. The feeder again is made of 300-ohm twin-lead since the feed-point impedance is approximately 300 ohms, the same as that of the twin-lead folded dipole.

The folded-dipole type of antenna has the broadest response characteristics (greatest

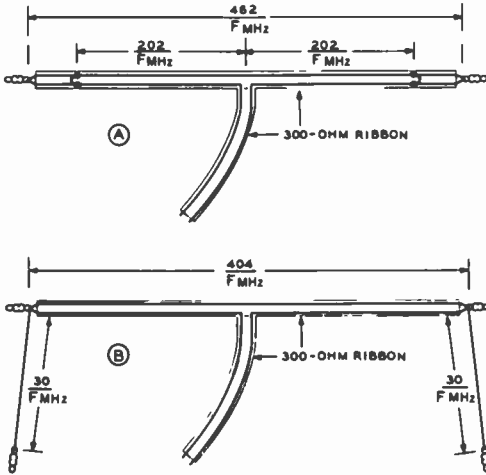

Figure 3

FOLDED DIPOLE WITH SHORTING STRAPS

The impedance match and bandwidth characteristics of a folded dipole may be improved by shorting the two wires of the ribbon a distance out from the center equal to the velocity factor of the ribbon times the half-length of the dipole as shown at A. An alternative arrangement with bent down ends for space conservation is illustrated at B.

bandwidth) of any of the conventional half-wave antenna systems constructed of small wires or conductors. Hence such an antenna may be operated over the greatest frequency range, without serious standing waves, of any common half-wave antenna types.

Delta-Matched Doublet and Standard Doublet These two types of radiating elements are shown in figure 2L and figure 2M.

The delta-matched doublet is described in detail in Section eight of this chapter. The standard doublet, shown in figure 2M, is fed in the center by means of 75-ohm transmitting type twin-lead.

The coaxial-fed doublet shown in figure 2N is a variation on the system shown in figure 2M. Either 52-ohm or 75-ohm coaxial cable may be used to feed the center of the dipole, although the 52-ohm type will give a somewhat better impedance match at lower antenna heights. Due to the asymmetry of the coaxial feed system, difficulty may be encountered with waves traveling

on the outside of the coaxial cable. For this reason the use of twin-lead is normally to be preferred over the use of coaxial cable for feeding the center of a half-wave dipole.

Off-Center-Fed Doublet The system shown in figure 2O is sometimes used to feed a half-wave dipole, especially when it is desired to use the same antenna on a number of harmonically related frequencies. The feeder wire (No. 14 enameled wire should be used) is tapped a distance of 14 percent of the total length of the antenna either side of center. The feeder wire, operating against ground for the return current, has an impedance of approximately 600 ohms.

The effectiveness of the antenna system in radiating harmonics is of course an advantage when operation of the antenna on a number of frequency bands is desired. But it is necessary to use a harmonic filter to ensure that only the desired frequency is fed from the transmitter to the antenna.

21-3 The Half-Wave Vertical Antenna

The half-wave vertical antenna with its bottom end from 0.1 to 0.2 wavelength above ground is an effective transmitting antenna for low-angle radiation, where ground conditions in the vicinity of the antenna are good. Such an antenna is not good for short-range sky-wave communication, such as is the normal usage of the 3.5-MHz amateur band, but is excellent for short-range ground-wave communication such as on the standard broadcast band

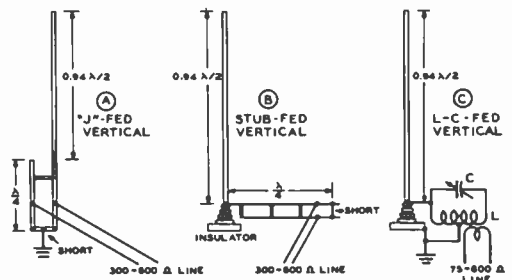

Figure 4

HALF-WAVE VERTICAL ANTENNA SHOWING ALTERNATIVE METHODS OF FEED

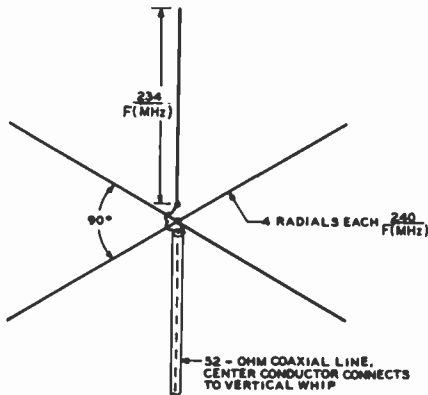

Figure 5

THE LOW-FREQUENCY GROUND PLANE ANTENNA

The radials of the ground plane antenna should lie in a horizontal plane, although slight departures from this caused by nearby objects is allowable. The whip may be mounted on a short post, or on the roof of a building. The wire radials may slope downwards toward their tips, acting as guy wires for the installation.

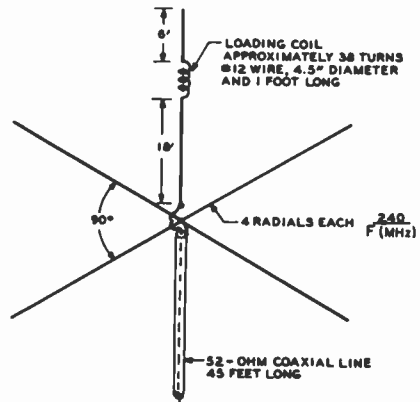

Figure 6

80-METER LOADED GROUND PLANE ANTENNA

Number of turns in loading coil to be adjusted until antenna system resonates at desired frequency in 80-meter band.

and on the amateur 1.8-MHz band. The vertical antenna may cause greater BCI than an equivalent horizontal antenna, due to the much greater ground-wave field intensity. Also, the vertical antenna is poor for receiving under conditions where man-made interference is severe, since such interference is predominantly of vertical polarization.

Three ways of feeding a half-wave vertical antenna with an untuned transmission line are illustrated in figure 4. The J-fed system shown in figure 4A is obviously not practical except on the higher frequencies where the extra length for the stub may easily be obtained. However, in the normal case the ground-plane vertical antenna is to be recommended over the J-fed system for high-frequency work.

21-4 The Ground-Plane Antenna

An effective low-angle radiator for any amateur band is the *ground-plane antenna*, shown in figure 5. So named because of the radial ground wires, the ground-plane antenna is not affected by soil conditions in its vicinity due to the creation of an arti-

ficial ground system by the radial wires. The base impedance of the ground plane is of the order of 30 to 35 ohms, and it may be fed with 52-ohm coaxial line with only a slight impedance mismatch. For a more exact match, the ground-plane antenna may be fed with a 72-ohm coaxial line and a quarter-wave matching section made of 52-ohm coaxial line.

The angle of radiation of the ground-plane antenna is quite low, and the antenna will be found more effective for communication over 400 miles or so on the 80 and 40 meter bands than a high-angle radiator, such as a dipole.

The 80-Meter Loaded Ground Plane A vertical antenna of 66 feet in height presents quite a problem on a small lot, as the supporting guy wires will tend to take up quite a large portion of the lot. Under such conditions, it is possible to shorten the length of the vertical radiator of the ground plane by the inclusion of a loading coil in the vertical whip section. The ground-plane antenna can be artificially loaded in this manner so that a 25-foot vertical whip may be used for the radiator. Such an antenna is shown in figure 6. The loaded ground plane tends to have a rather high *Q* and operates only over a narrow band of frequencies. An operating range of

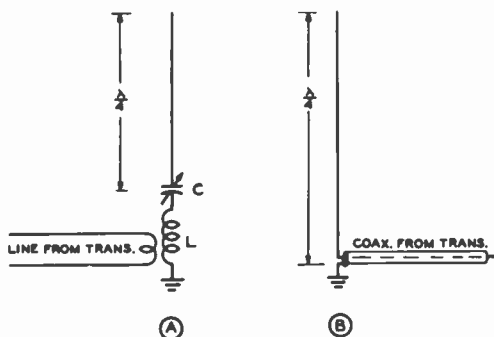

Figure 7

FEEDING A QUARTER-WAVE MARCONI ANTENNA

When an open-wire line is to be used, it may be link-coupled to a series-resonant circuit between the bottom end of the Marconi and ground, as at A. Alternatively, a reasonably good impedance match may be obtained between 52-ohm coaxial line and the bottom of a resonant quarter-wave antenna, as illustrated at B above.

about 100 kHz with a low SWR is possible on 80 meters. Operation over a larger frequency range is possible if a higher standing wave ratio is tolerated on the transmission line. The radiation resistance of a loaded 80-meter ground plane is about 15 ohms.

21-5 The Marconi Antenna

A grounded quarter-wave *Marconi antenna*, widely used on frequencies below 3 MHz, is sometimes used on the 3.5-MHz band, and is also used in vhf mobile services where a compact antenna is required. The Marconi type antenna allows the use of half the length of wire that would be required for a half-wave Hertz radiator. The ground acts as a mirror, in effect, and takes the place of the additional quarter wave of wire that would be required to reach resonance if the end of the wire were not returned to ground.

The fundamental practical form of the Marconi antenna system is shown in figure 7. Other Marconi antennas differ from this type primarily in regard to the method of feeding the energy to the radiator. The feed method shown in figure 7B can often be used to advantage, particularly in mobile work.

Variations on the basic Marconi antenna are shown in the illustrations of figure 8. Figures 8B and 8C show the L-type and T-type Marconi antennas. These arrangements have been more or less superseded by the top-loaded forms of the Marconi antenna shown in figures 8D, 8E, and 8F. In each of these latter three configurations an antenna somewhat less than one quarter wave in length has been *loaded* to increase its effective length by the insertion of a *loading coil* at or near the top of the radiator. The arrangement shown at figure 8D gives the least loading but is the most practical mechanically. The system shown at figure 8E gives an intermediate amount of loading, while that shown at figure 8F, utilizing a "hat" just above the loading coil, gives the greatest amount of loading. The object of all the top-loading methods shown is to produce an increase in the effective length of the radiator, and thus to raise the point of maximum current in the radiator as far as possible above ground. Raising the maximum-current point in the radiator above ground has two desirable results: The percentage of low-angle radiation is increased and the amount of ground current at the base of the radiator is reduced, thus reducing the ground losses.

Amateurs primarily interested in the higher-frequency bands, but liking to work 80 meters occasionally, can usually manage to resonate one of their antennas as a Marconi by working the whole system (feeders and all) against a water pipe ground, and resorting to a loading coil if necessary. A high-frequency rotary, zepp, doublet, or single-wire-fed antenna will make quite a good 80-meter Marconi if high and in the clear, with a rather long feed line to act as a radiator on 80 meters.

Importance of Ground Connection With a quarter-wave antenna and a ground, the antenna current generally is measured with a meter placed in the antenna circuit close to the ground connection. If this current flows through a resistor, or if the ground itself presents some resistance, there will be a power loss in the form of heat. Improving the ground connection, therefore, provides a definite

Figure 8

LOADING THE MARCONI ANTENNA

The various loading systems are discussed in the accompanying text.

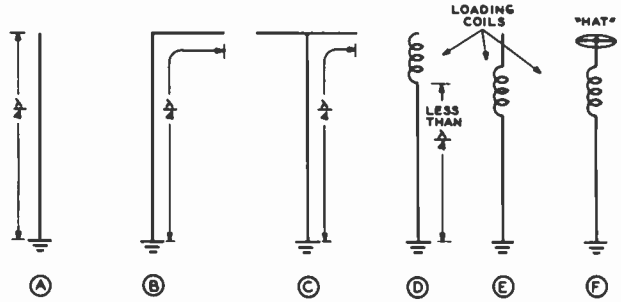

means of reducing this power loss, and thus increasing the radiated power.

The best possible ground consists of as many wires as possible, each at least a quarter wave long, buried just below the surface of the earth, and extending out from a common point in the form of *radials*. Copper wire of any size larger than No. 16 is satisfactory, and the larger sizes will take longer to disintegrate. In fact, the radials need not even be buried; they may be supported just above the earth, and insulated from it. This arrangement is called a *counterpoise*, and operates by virtue of its high capacitance to ground.

If the antenna is physically shorter than a quarter wavelength, the antenna current is higher, due to lower radiation resistance; consequently, the power lost in resistive soil is greater. The importance of a good ground with short, inductive-loaded Marconi radiators is, therefore, quite obvious. With a good ground system, even very short (one-eighth wavelength) antennas can be expected to give a high percentage of the efficiency of a quarter-wave antenna used with the same ground system. This is especially true when the short radiator is *top loaded* with a high-Q (low-loss) coil.

Water-Pipe Grounds Water pipe, because of its comparatively large surface and cross section, has a relatively low r-f resistance. If it is possible to attach to a junction of several water pipes (where they branch in several directions and run for some distance under ground), a satisfactory ground connection will be obtained. If one of the pipes attaches to a lawn or garden sprinkler system in the immediate vicinity of the antenna, the effectiveness of

the system will approach that of buried copper radials.

The main objection to water-pipe grounds is the possibility of high-resistance joints in the pipe, due to the "dope" put on the coupling threads. By attaching the ground wire to a junction with three or more legs, the possibility of requiring the main portion of the r-f current to flow through a high resistance connection is greatly reduced.

Marconi Dimensions A Marconi antenna is an odd number of electrical quarter waves long (usually only one

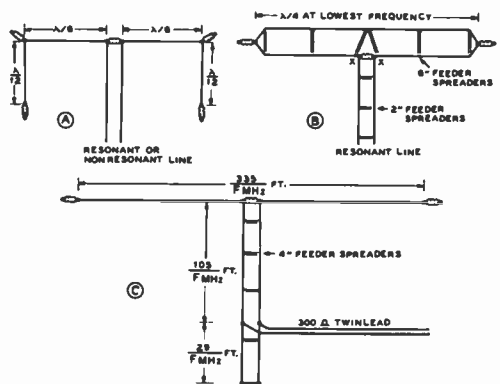

Figure 9

THREE EFFECTIVE SPACE-CONSERVING ANTENNAS

The arrangements shown at A and B are satisfactory where resonant feed line can be used. However, nonresonant 75-ohm feed line may be used in the arrangement at A when the dimensions in wavelengths are as shown. In the arrangement shown at B, low standing waves will be obtained on the feed line when the over-all length of the antenna is a half wave. The arrangement shown at C may be tuned for any reasonable length of flat top to give a minimum of standing waves.

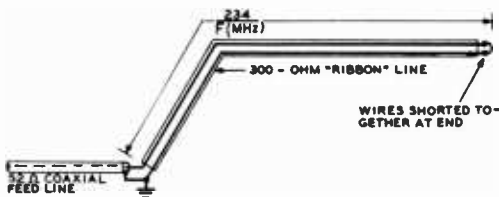

Figure 10

TWIN-LEAD MARCONI ANTENNA FOR THE 80- AND 160-METER BANDS

quarter wave in length), and is always resonated to the operating frequency. The correct loading of the final amplifier is accomplished by varying the coupling, rather than by detuning the antenna from resonance.

Physically, a quarter-wave Marconi may be made anywhere from one-eighth to three-eighths wavelength overall, including the total length of the antenna wire and ground lead from the end of the antenna to the point where the ground lead attaches to the junction of the radials or counterpoise wires, or where the water pipe enters the ground. The longer the antenna is made physically, the lower will be the current flowing in the ground connection, and the greater will be the over-all radiation efficiency. However, when the antenna length exceeds three-eighths wavelength, the antenna becomes difficult to resonate by means of a series capacitor, and it begins to take shape as an end-fed Hertz, requiring a method of feed such as a pi-network.

A radiator physically much shorter than a quarter wavelength can be lengthened electrically by means of a series loading coil, and used as a quarter-wave Marconi. However, if the wire is made shorter than approximately one-eighth wavelength, the radiation resistance will be quite low. This is a special problem in mobile work below about 20-MHz.

21-6 Space-Conserving Antennas

In many cases it is desired to undertake a considerable amount of operation on the 80- or 40-meter band, but sufficient space is simply not available for the installation of

a half-wave radiator for the desired frequency of operation. This is a common experience of apartment dwellers. The shortened Marconi antenna operated against a good ground *can* be used under certain conditions, but the shortened Marconi is notorious for the production of broadcast interference and a good ground connection is usually unobtainable in an apartment house.

Essentially, the technique of producing an antenna for lower-frequency operation in restricted space is to erect a short radiator which is balanced with respect to ground and which is therefore independent of ground for its operation. Several antenna types meeting this set of conditions are shown in figure 9. Figure 9A shows a conventional center-fed doublet with bent-down ends. This type of antenna can be fed with 75-ohm twin-lead in the center, or it may be fed with a resonant line for operation on several bands. The over-all length of the radiating wire will be a few percent greater than the normal length for such an antenna since the wire is bent at a position intermediate between a current loop and a voltage loop. The actual length will have to be determined by the cut-and-try process because of the increased effect of interfering objects on the effective electrical length of an antenna of this type.

Figure 9B shows a method for using a two-wire doublet on one-half of its normal operating frequency. It is recommended that spaced open conductor be used both for the radiating portion of the folded dipole and for the feed line. The reason for this lies in the fact that the two wires of the flat top are *not* at the same potential throughout their length when the antenna is operated on one-half frequency. Twin-lead may be used for the feed line if operation on the frequency where the flat top is one half-wave in length is most common, and operation on half frequency is infrequent. However, if the antenna is to be used primarily on the half frequency as shown, it should be fed by means of an open-wire line. If it is desired to feed the antenna with a nonresonant line, a quarter-wave stub may be connected to the antenna at the points X—X in figure 9B. The stub should be tuned and the transmission line connected to it in the normal manner.

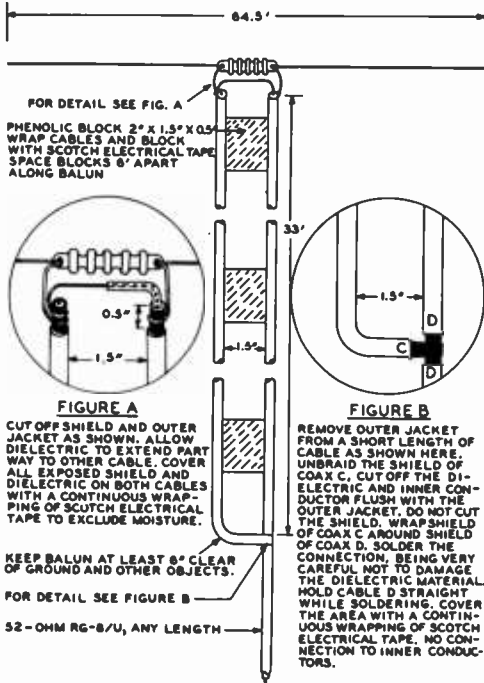

Figure 11

HALF-WAVE ANTENNA WITH QUARTER-WAVE UNBALANCED-TO-BALANCED TRANSFORMER (BALUN) FEED SYSTEM FOR 40-METER OPERATION

The antenna system shown in figure 9C may be used when not quite enough length is available for a full half-wave radiator. The dimensions in terms of frequency are given on the drawing. An antenna of this type is 93 feet long for operation on 3600 kHz and 86 feet long for operation on 3900 kHz. This type of antenna has the additional advantage that it may be operated on the 7- and 14-MHz bands, when the flat top has been cut for the 3.5-MHz band, simply by changing the position of the shorting bar and the feeder line on the stub.

A sacrifice which must be made when using a shortened radiating system (as for example the types shown in figure 9), is in the bandwidth of the radiating system. The frequency range which may be covered

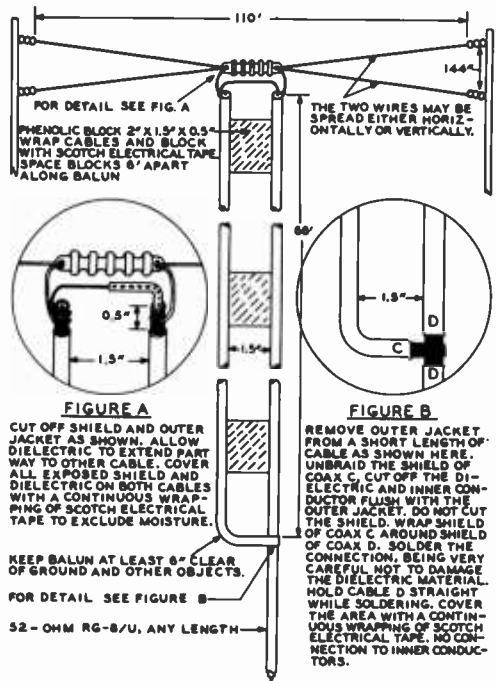

Figure 12

BROADBAND ANTENNA WITH QUARTER-WAVE UNBALANCED-TO-BALANCED TRANSFORMER (BALUN) FEED SYSTEM FOR 80-METER OPERATION

by a shortened antenna system is approximately in proportion to the amount of shortening which has been employed. For example, the antenna system shown in figure 9C may be operated over the range from 3800 to 4000 kHz without serious standing waves on the feed line. If the antenna had been made full length it would be possible to cover about half again as much frequency range for the same amount of mismatch at the extremes of the frequency range.

The Twin-Lead Marconi Antenna Much of the power loss in the Marconi antenna is a result of low radiation resistance and high ground resistance. In some cases, the ground resistance may even be

higher than the radiation resistance, causing a loss of 50 percent or more of the transmitter power output. If the radiation resistance of the Marconi antenna is raised, the amount of power lost in the ground resistance is proportionately less. If a Marconi antenna is made out of 300-ohm TV-type ribbon line, as shown in figure 10, the radiation resistance of the antenna is raised from a low value of 10 or 15 ohms to a more reasonable value of 40 to 60 ohms. The ground losses are now reduced by a factor of 4. In addition, the antenna may be directly fed from a 50-ohm coaxial line, or directly from the unbalanced output of a pi-network transmitter.

Since a certain amount of power may still be lost in the ground connection, it is still of greatest importance that a good, low-resistance ground be used with this antenna.

A Broadband Dipole System Shown in figures 11 and 12 are broadband dipoles for the 40- and 80-meter amateur bands. These fan-type dipoles have excellent broadband response, and are designed to be fed with a 52-ohm unbalanced coaxial line. The antenna system consists of a fan-type dipole, a balun matching section, and a suitable coaxial feedline. The Q of the half-wave 80-meter doublet is lowered by decreasing the effective length-to-diameter ratio. The frequency range of operation of the doublet is increased considerably by this change. A typical SWR curve for the 80-meter doublet is shown in figure 13.

The balanced doublet is matched to the unbalanced coaxial line by the quarter-wave balun. If desired, a shortened balun may be used (figure 14). The short balun is capacitance loaded at the junction between the balun and the broadband dipole.

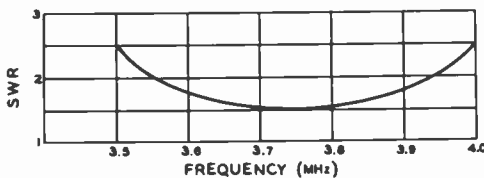

Figure 13

SWR CURVE OF 80-METER BROADBAND DIPOLE

The Inverted-V Antenna The *Inverted-V* antenna is a center-fed dipole with the ends lower than the middle.

The radiation pattern is similar to a dipole, except that more radiation is apparent off the ends of the antenna. The main advantage of this antenna is that it may be hung, or supported, at the center from an existing tower, with the ends tied off near the surface of the ground. For 40- or 80-meter inverted V's, the center support should be from 40 to 60 feet above ground and the ends should clear the ground by at least 10 feet.

The impedance of an inverted V is less than that of an equivalent dipole placed at the apex of the array, however, a good match may be had to 50-ohm coaxial transmission line. Bandwidth is about equal to that of a regular horizontal dipole.

The length of the inverted V is less than that of a dipole and may be computed from the following formula:

$$\text{Over-all length (feet)} = \frac{464}{f_{\text{MHz}}}$$

Objects near the end of the inverted V will affect the resonant frequency to some extent and the installation may require end trimming to bring it on or near the desired frequency, especially in the presence of nearby buildings, telephone wires or other conductors. For best results, a balun should be used between the inverted V and the coaxial feedline.

21-7 Multiband Antennas

The availability of a *multiband antenna* is a great operating convenience to an amateur station. In most cases it will be found best to install an antenna which is optimum for the band which is used for the majority of the available operating time, and then to have an additional multiband antenna which may be pressed into service for operation on another band when propagation conditions on the most frequently used band are not suitable.

The choice of a multiband antenna depends on a number of factors such as the

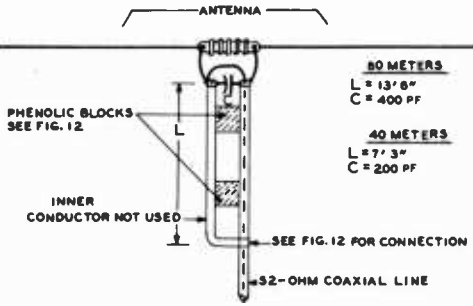

Figure 14

SHORT BALUN FOR 40 AND 80 METERS

amount of space available, the band which is to be used for the majority of operation with the antenna, the radiation efficiency which is desired, and the type of antenna tuning network to be used at the transmitter. A number of recommended types are shown on the next pages.

The 3/4-Wave Folded Doublet Figure 15 shows an antenna type which will be found to be very effective when a moderate amount of space is available, when most of the operating will be done on one band with occasional operation on the second harmonic. The system is quite satisfactory for use with high-power transmitters since a 600-ohm nonresonant line is

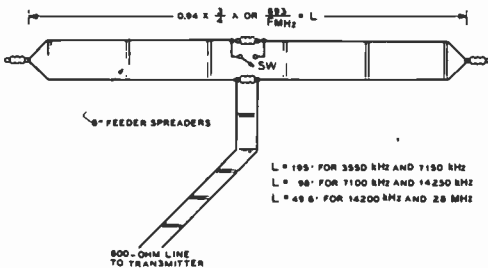

Figure 15

THE THREE-QUARTER WAVE FOLDED DOUBLET

This antenna arrangement will give very satisfactory operation with a 600-ohm feed line for operation with the switch open on the fundamental frequency and with the switch closed on twice frequency. A balun may be used to match the 600-ohm line to the transmitter.

used from the antenna to the transmitter and since the antenna system is balanced with respect to ground. With operation on the fundamental frequency of the antenna where the flat top is 3/4 wave long the switch SW is left open. The system affords a very close match between the 600-ohm line and the feed point of the antenna. A standing-wave ratio of approximately 1.2 to 1 over the 14-MHz band exists when the antenna is located approximately one-half wave above ground.

For operation on the second harmonic the switch SW is closed. The antenna is still an effective radiator on the second harmonic but the pattern of radiation will be different from that on the fundamental, and the standing-wave ratio on the feed line will be greater. The flat top of the antenna must be made of open wire rather than ribbon or tubular line.

For greater operating convenience, the shorting switch may be replaced with a section of transmission line. If this transmission line is made one-quarter wavelength long for the fundamental frequency, and the free end of the line is shorted, it will act as an open circuit across the center insulator. At the second harmonic, the transmission line is one-half wavelength long, and reflects the low impedance of the shorted end across the center insulator. Thus the switching action is automatic as the frequency of operation is changed. Such an installation is shown in figure 16.

The End-Fed Hertz The end-fed Hertz antenna shown in figure 17 is not as effective a radiating system as many other antenna types, but it is particularly convenient when it is desired to install an antenna in a hurry for a test, or for field-day work. The flat top of the radiator should be as high and in the clear as possible. In any event at least three quarters of the total wire length should be in the clear.

The End-Fed Zepp The end-fed zepp is convenient for multiband operation. It is shown in figure 18 along with recommended dimensions for operation on various amateur band groups. Since

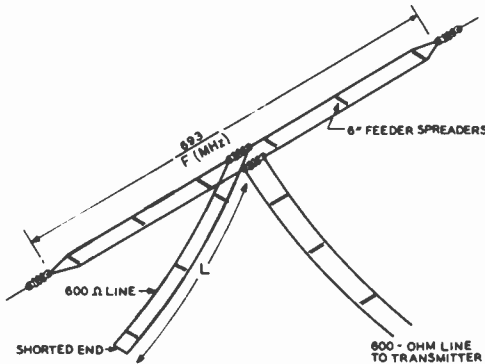

L = 67 FT. WHEN ANTENNA IS 195 FT.
 L = 33 FT. " " " 98 FT.
 L = 16.5 FT. " " " 49.6 FT.

Figure 16

AUTOMATIC BANDSWITCHING STUB FOR THE THREE-QUARTER WAVE FOLDED DOUBLET

The antenna of Figure 15 may be used with a shorted stub line in place of the switch normally used for second-harmonic operation.

this antenna type is an unbalanced radiating system, its use is not recommended with high-power transmitters where interference to broadcast listeners is likely to be encountered.

The coupling coil at the transmitter end of the feeder system should be link-coupled to the output of the low-pass TVI filter in order to reduce harmonic radiation.

The Two-Band Marconi Antenna A three-eighths wavelength Marconi antenna may be operated on its harmonic frequency, providing good two band per-

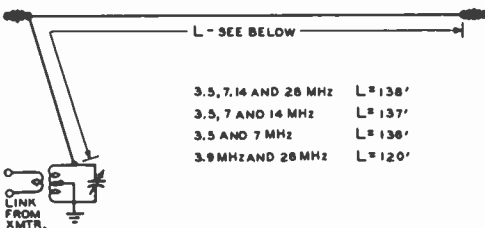

3.5, 7, 14 AND 28 MHz L = 138'
 3.5, 7 AND 14 MHz L = 137'
 3.5 AND 7 MHz L = 130'
 3.9 MHz AND 28 MHz L = 120'

Figure 17

RECOMMENDED LENGTHS FOR THE END-FED HERTZ ANTENNA

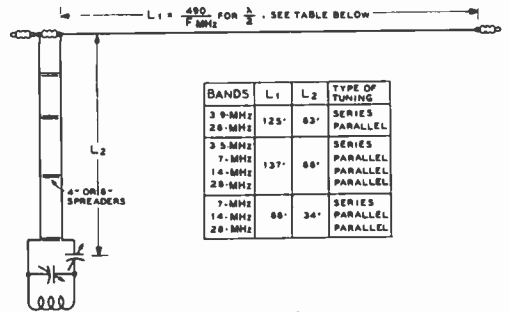

Figure 18
END-FED ZEPP

BANDS	L1	L2	TYPE OF TUNING
3.9-MHz 28-MHz	125'	63'	SERIES PARALLEL
3.5-MHz 7-MHz 14-MHz 28-MHz	137'	68'	SERIES PARALLEL PARALLEL PARALLEL
7-MHz 14-MHz 28-MHz	68'	34'	SERIES PARALLEL PARALLEL

formance from a simple wire. Such an arrangement for operation on 160-80 meters, and 80-40 meters is shown in figure 19. On the fundamental (lowest) frequency, the antenna acts as a three-eighths wavelength series-tuned Marconi. On the second harmonic, the antenna is a current-fed three-quarter wavelength antenna operating against ground. For proper operation, the antenna should be resonated on its second harmonic by means of a grid-dip oscillator to the operating frequency most used on this particular band. The Q of the antenna is relatively low, and the antenna will perform well over a frequency range of several hundred kHz.

The over-all length of the antenna may be varied slightly to place its self-resonant frequency in the desired region. Bends or turns in the antenna tend to make it resonate higher in frequency, and it may be necessary to lengthen it a bit to resonate it at the chosen frequency. For fundamental operation, the series capacitor is inserted in the circuit, and the antenna may be resonated to any point in the lower-frequency

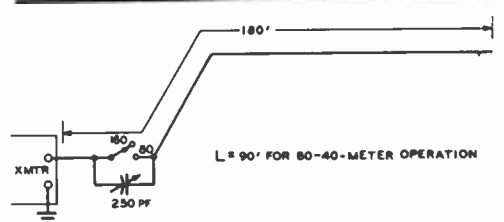

Figure 19

A TWO-BAND MARCONI ANTENNA FOR 160-80 METER OPERATION

band. As with any Marconi-type antenna, the use of a good ground is essential. This antenna works well with transmitters employing coaxial antenna feed, since its transmitting impedance on both bands is in the neighborhood of 40 to 60 ohms. It may be attached directly to the output terminal of a pi-network transmitter coupling circuit. The use of a low-pass TVI filter is of course recommended.

The Center-Fed Multiband Antenna For multiband operation, the center-fed antenna is without doubt the best compromise. It is a balanced system on all bands, it requires no ground return, and when properly tuned has good rejection properties for the higher harmonics generated in the transmitter. It is well suited for use with the various multiband 150-watt transmitters that are currently so popular. For proper operation with these transmitters, an antenna tuning unit *must* be used with the center-fed antenna. In fact, some sort of tuning unit is necessary for any type of efficient, multiband antenna.

Various dimensions for center-fed antenna systems are shown in figure 20. If the feed line is made up in the conventional manner of No. 12 or No. 14 wire spaced 4 to 6 inches, the antenna system is sometimes called a *center-fed zepp*. With this

type of feeder the impedance at the transmitter end of the feeder varies from about 70 ohms to approximately 5000 ohms, the same range encountered in an end-fed zepp antenna. This great impedance ratio requires provision for either series or parallel tuning of the feeders at the transmitter, and involves quite high r-f voltages at various points along the feed line.

If the feed line between the transmitter and the antenna is made to have a characteristic impedance of approximately 300 ohms the excursions in end-of-feeder impedance are greatly reduced.

There are several practical types of transmission line which can give an impedance of approximately 300 ohms. The first is, obviously, 300-ohm twin-lead. Twin-lead of the receiving type *may* be used as a resonant feed line in this case, but its use is not recommended with power levels greater than perhaps 150 watts, and it should not be used when lowest loss in the transmission line is desired.

For power levels up to 250 watts or so, the transmitting type tubular 300-ohm line may be used, or the open-wire 300-ohm TV line may be employed. For power levels higher than this, a 4-wire transmission line, or a line built of one-quarter inch tubing should be used.

Even when a 300-ohm transmission line is used, the end-of-feeder impedance may reach a high value, particularly on the second harmonic of the antenna. To limit the

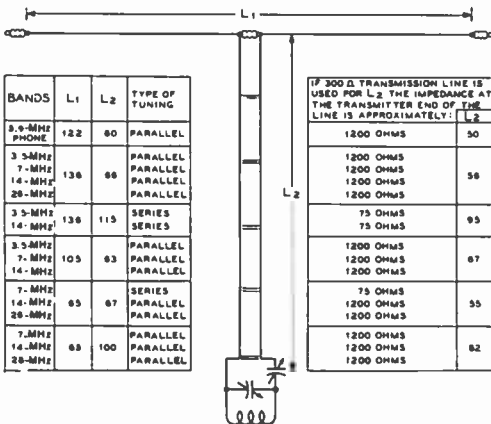

Figure 20

DIMENSIONS FOR CENTER-FED MULTIBAND ANTENNA

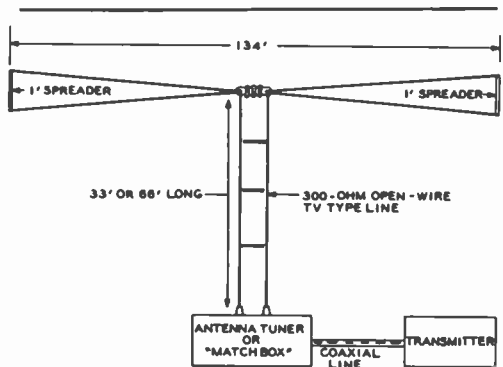

Figure 21

MULTIBAND ANTENNA USING FAN-DIPOLE TO LIMIT IMPEDANCE EXCURSIONS ON HARMONIC FREQUENCIES

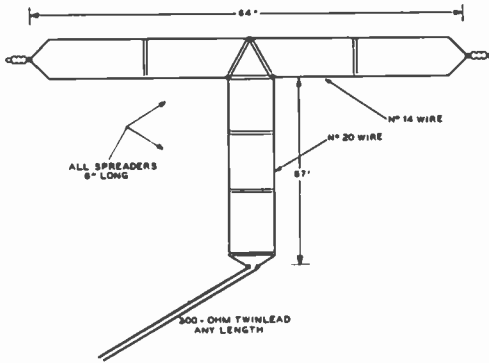

Figure 22

FOLDED-TOP DUAL-BAND ANTENNA

impedance excursions, a two-wire flat top may be employed for the radiator, as shown in figure 21. The use of such a radiator will limit the impedance excursions on the harmonic frequencies of the antenna and make the operation of the antenna matching unit much less critical. The use of a two-wire radiator is highly recommended for any center-fed multiband antenna.

Folded Flat Top Dual-Band Antenna As has been mentioned earlier, there is an increasing tendency among amateur operators to utilize rotary or fixed arrays for the 14-MHz band and those higher in frequency. In order to afford complete coverage of the amateur bands it is then desirable to have an additional system which will operate with equal effectiveness on the 3.5- and 7-MHz bands, but this low-frequency antenna system will not be required to operate on any bands higher in frequency than the 7-MHz band. The antenna system shown in figure 22 has been developed to fill this need.

This system consists essentially of an open-wire folded dipole for the 7-MHz band with a special feed system which allows the antenna to be fed with minimum standing waves on the feed line on both the 7-MHz and 3.5-MHz bands. The feed-point impedance of a folded dipole on its fundamental frequency is approximately 300 ohms. Hence the 300-ohm twin lead shown in figure 22 can be connected directly into the center of the system for operation only on

the 7-MHz band and standing waves on the feeder will be very small. However, it is possible to insert an electrical half wave of transmission line of any characteristic impedance into a feeder system such as this and the impedance at the far end of the line will be exactly the same value of impedance which the half-wave line "sees" at its termination. Hence this has been done in the antenna system shown in figure 22; an electrical half wave of line has been inserted between the feed point of the antenna and the 300-ohm transmission line to the transmitter.

The characteristic impedance of this additional half-wave section of transmission line has been made about 715 ohms (No. 20 wire spaced 6 inches), but since it is an electrical half wave long at 7 MHz and operates into a load of 300 ohms at the antenna the 300-ohm twin lead at the bottom of the half-wave section still "sees" an impedance of 300 ohms. The additional half-wave section of transmission line introduces a negligible amount of loss since the current flowing in the section of line is the same which would flow in a 300-ohm line at each end of the half-wave section, and at all other points it is *less* than the current which would flow in a 300-ohm line since the effective impedance is *greater* than 300 ohms in the center of the half-wave section. This means that the loss is less than it would be in an equivalent length of 300-ohm twin lead since this type of manufactured transmission line is made up of conductors which are equivalent to No. 20 wire.

So we see that the added section of 715-ohm line has substantially no effect on the operation of the antenna system on the 7-MHz band. However, when the flat top of the antenna is operated on the 3.5 MHz band the feed-point impedance of the flat top is approximately 3500 ohms. Since the section of 715-ohm transmission line is an electrical *quarter-wave* in length on the 3.5-MHz band, this section of line will have the effect of transforming the approximately 3500 ohms feed-point impedance of the antenna down to an impedance of about 150 ohms which will result in a 2:1 standing-wave ratio on the 300-ohm twin lead transmission line from the transmitter to the antenna system.

The antenna system of figure 22 operates with very low standing waves over the entire 7-MHz band, and it will operate with moderate standing waves from 3500 to 3800 kHz in the 3.5-MHz band and with sufficiently low standing-wave ratio so that it is quite usable over the entire 3.5-MHz band.

This antenna system, as well as all other types of multiband antenna systems, should be used in conjunction with some type of harmonic-reducing antenna tuning network even though the system does present a convenient impedance value on both bands.

The Multee Antenna An antenna that works well on 160 and 80 meters, or 80 and 40 meters and is sufficiently compact to permit erection on the average city lot is the *Multee* antenna, illustrated in figure 23.

The antenna evolves from a vertical two-wire radiator, fed on one leg only. On the low-frequency band the top portion does little radiating, so it is folded down to form a radiator for the higher-frequency band. On the lower-frequency band, the antenna acts as a top-loaded vertical radiator, while on the higher-frequency band, the flat top does the radiating rather than the vertical portion. The vertical portion acts as a quarter-wave linear transformer, matching the 6000-ohm antenna impedance to the 50-ohm impedance of the coaxial transmission line.

The earth below a vertical radiator must be of good conductivity not only to provide a low-resistance ground connection, but also to provide a good reflecting surface for the waves radiated downward toward the ground. For best results, a radial system should be installed beneath the antenna. For 160/80-meter operation, six radials 50 feet in length, made of No. 16 copper wire should be buried just below the surface of the ground. While an ordinary water-pipe ground system with no radials may be used, a system of radials will provide a worthwhile increase in signal strength. For 80/40-meter operation, the length of the radials may be reduced to 25 feet. As with all multiband antennas that employ no lumped tuned circuits, this antenna offers no attenuation to harmonics of the transmitter. When operating on the lower-frequency band, it would

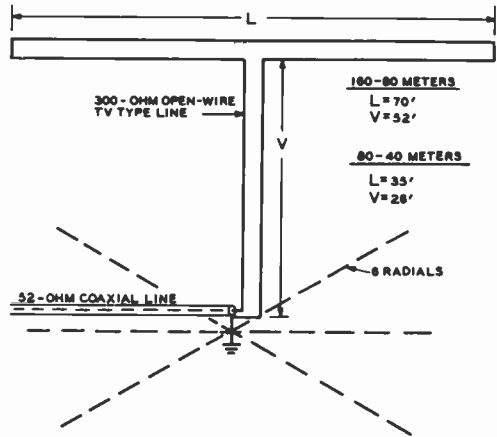

Figure 23

THE MULTEE TWO-BAND ANTENNA

This compact antenna can be used with excellent results on 160/80 and 80/40 meters. The feedline should be held as vertical as possible, since it radiates when the antenna is operated on its fundamental frequency.

be wise to check the transmitter for second-harmonic emission, since this antenna will effectively radiate this harmonic.

The Low-Frequency Discone The *discone* antenna is widely used on the vhf bands, but until recently

it has not been put to any great use on the lower-frequency bands. Since the discone is a broadband device, it may be used on several harmonically related amateur bands. Size is the limiting factor in the use of a discone, and the 20-meter band is about the lowest practical frequency for a discone of reasonable dimensions. A discone designed for 20-meter operation may be used on 20, 15, 11, 10, and 6 meters with excellent results. It affords a good match to a 50-ohm coaxial feed system on all of these bands. A practical discone antenna is shown in figure 24, with a SWR curve for its operation over the frequency range of 13 to 55 MHz shown in figure 25. The discone antenna radiates a vertically polarized wave and has a very low angle of radiation. For vhf work the discone is constructed of sheet metal, but for low-frequency work it may be made of copper wire and aluminum angle stock. A

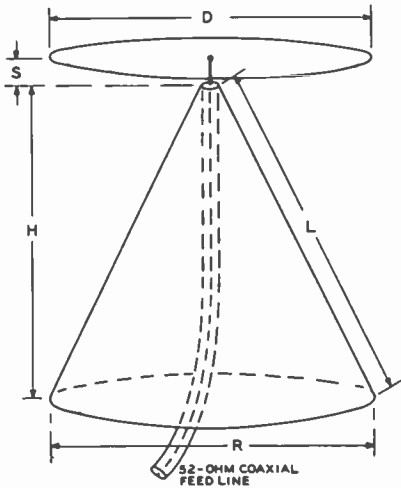

DIMENSIONS

20, 15, 11, 10, 6 METERS	15, 11, 10, 6 METERS	11, 10, 6, 2 METERS
D=12' L=18'	D=8' L=12'	D=6' L=9'6"
S=10" R=18'	S=6" R=12'	S=4" R=9'6"
H=15'7"	H=10'5"	H=8'3"

Figure 24

DIMENSIONS OF DISCONE ANTENNA FOR LOW-FREQUENCY CUTOFF AT 13.2 MHz, 20.1 MHz, AND 26 MHz

The Discone is a vertically polarized radiator, producing an omnidirectional pattern similar to a ground plane. Operation on several amateur bands with low SWR on the coaxial feed line is possible.

suitable mechanical layout for a low-frequency discone is shown in figure 26. Smaller versions of this antenna may be constructed for 15, 11, 10, and 6 meters, or for 11, 10, 6, and 2 meters as shown in figure 24.

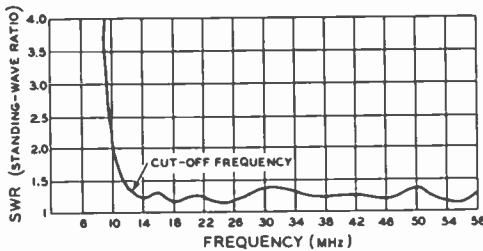

Figure 25

SWR CURVE FOR A 13.2-MHz DISCONE ANTENNA. SWR IS BELOW 1.5 TO 1 FROM 13.0 MHz TO 58 MHz

For minimum wind resistance, the top "hat" of the discone is constructed from three-quarter inch aluminum angle stock, the rods being bolted to an aluminum plate at the center of the structure. The tips of the rods are all connected together by lengths of No. 12 enamelled copper wire. The cone elements are made of No. 12 copper wire and act as guy wires for the discone structure. A very rigid arrangement may be made from this design, one that will give no trouble in high winds. A 4" x 4" post can be used to support the discone structure.

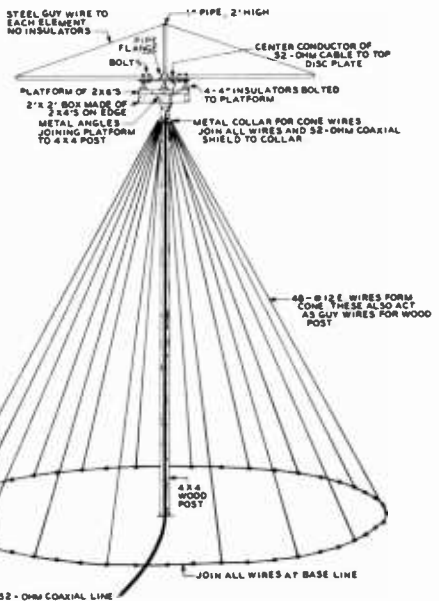
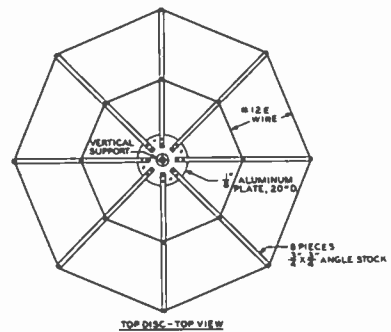

Figure 26

MECHANICAL CONSTRUCTION OF 20-METER DISCONE

The discone antenna may be fed by a length of 50-ohm coaxial cable directly from the transmitter, with a very low SWR on all bands.

The Single-Wire-Fed Antenna The old favorite *single-wire-fed antenna* system is quite satisfactory for an impromptu all-band antenna system. It is widely used for portable installations and "Field Day" contests where a simple, multi-band antenna is required. A single-wire feeder has a characteristic impedance of approximately 500 ohms, depending on the wire size and the point of attachment to the antenna. The earth losses are comparatively low over ground of good conductivity. Since the single-wire feeder radiates, it is necessary to bring it away from the antenna at right angles to the antenna wire for at least one-half the length of the antenna.

The correct point for best impedance match on the fundamental frequency is not suitable for harmonic operation of the antenna. In addition, the correct length of the antenna for fundamental operation is not correct for harmonic operation. Consequently, a compromise must be made in antenna length and point of feeder connection to enable the single-wire-fed antenna to operate on more than one band. Such a compromise introduces additional reactance into the single-wire feeder, and might cause loading difficulties with pi-network transmitters. To minimize this trouble, the single-wire feeder should be made a multiple of 33 feet long.

Two typical single-wire-fed antenna systems are shown in figure 27 with dimensions for multiband operation.

Multiband Vertical Antennas A vertical radiator can be used on several amateur bands either by employing a variable base-loading inductor or by the inclusion of trap elements in the radiator. In either case, tuned radial wires should be used for lowest ground loss at the higher frequencies. Shown in figure 28 is a 22-foot vertical antenna designed for operation on amateur bands from 80 through 10 meters. The height is chosen to present a $\frac{3}{4}$ -wavelength vertical for low angle radiation at the highest frequency of operation. Radial wires are used for the 10-, 15-, and 20-

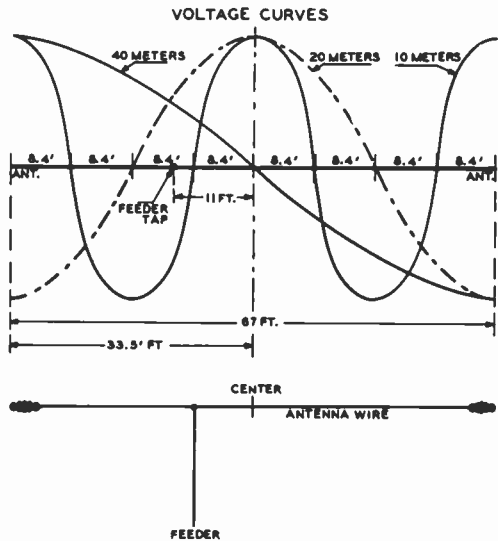

Figure 27

SINGLE-WIRE-FED ANTENNA FOR ALL-BAND OPERATION

An antenna of this type for 40-, 20- and 10-meter operation would have a radiator 67 feet long, with the feeder tapped 11 feet off center. The feeder can be 33, 66 or 99 feet long. The same type of antenna for 80-, 40-, 20- and 10-meter operation would have a radiator 134 feet long, with the feeder tapped 22 feet off center. The feeder can be either 66 or 132 feet long. This system should be used only with those coupling methods which provide good harmonic attenuation.

meter bands and an external ground connection is used on 40 and 80 meters. If the antenna is mounted on the roof of a building, it may be possible to use the metal rain gutter system as a ground.

Four-wire TV rotator cable can be used to construct the radial system, each cable including a radial wire for one of the three higher bands. The fourth wire may be extended for 40 meters, or two of the four wires can be cut for 20 meters, and one each for 15 and 10 meters. At least three and preferably four such radial assemblies should be used. These can be laid out on the roof, or possibly hidden in the attic.

The radiator is made from two ten-foot sections of aluminum TV mast, plus one five-foot section cut to the proper length. The mast sections are assembled and self-tapping sheet-metal screws are run

through each joint to make a good electrical connection. The radiator and base coil are attached to sturdy ceramic "beehive" insulators, using strips of aluminum bent to form clamps to encircle the tubing. The insulators are mounted to a vertical section of "two-by-four" lumber bolted to the frame of the building. If securely mounted, no guy wires are required for the vertical radiator.

The antenna is resonated to the center of each operative band with the aid of a SWR meter placed in the 52-ohm feedline. The taps are adjusted as indicated in the chart and sufficient power is applied to the antenna to cause a reading on the SWR meter. The number of active turns in the coil and the feedline tap are varied a turn at a time until proper transmitter loading is

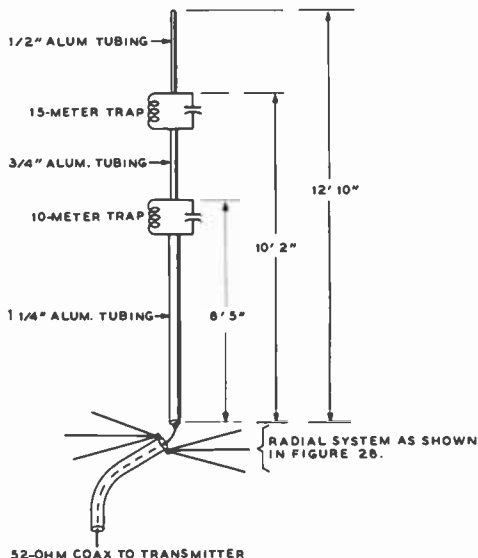

Figure 29

TRIBAND TRAP VERTICAL ANTENNA

Parallel-tuned trap assemblies are used in this vertical antenna designed for 20-, 15-, and 10-meter operation. The radial system of figure 28 is used. Automatic trap action electrically switches antenna for proper operation on each band.

achieved with a reasonably low value of SWR on the transmission line (below 1.5/1 or so at the center frequency in each band).

The trap technique described in the *Directive Antennas* chapter can be used for a three-band vertical antenna as shown in figure 29. This antenna is designed for operation on 10, 15, and 20 meters and uses a separate radial system for each band. No adjustments need to be made to the antenna when changing frequency from one band to another. Substitution of a ground connection for the radials is not recommended because of the high ground loss normally encountered at these frequencies. Typical trap construction is discussed in the reference chapter, and the vertical radiator is built of sections of aluminum tubing, as described earlier.

Each trap is built and grid-dipped to the proper frequency before it is placed in the radiator assembly. The 10-meter trap is self-resonant at about 27.9 MHz and the 15-meter trap is self-resonant at about 20.8

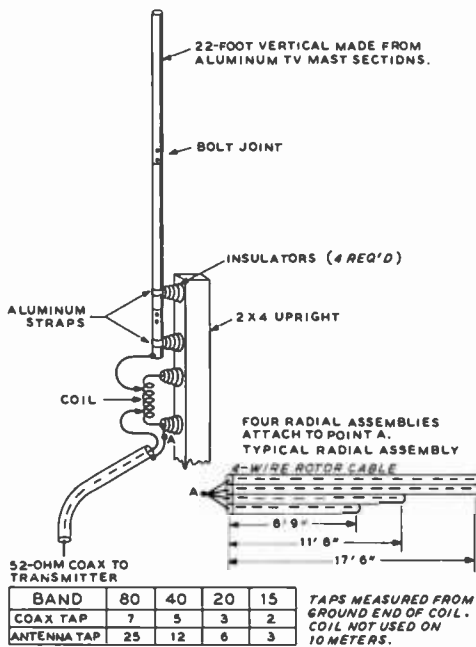

Figure 28

"ALL-BAND" VERTICAL ANTENNA

Base-loaded whip and multiple radial system may be used on all bands from 80 through 10 meters. Loading-coil taps are adjusted for lowest SWR on each band. The SWR on 10 meters may be improved by placing a 250-pf capacitor in series with the feedline connection to the base of the antenna and adjusting the capacitor for minimum SWR. Coil is 40 turns, 2" in diameter, 4" long (Air-Dux 1610).

MHz. Once resonated, the traps need no further adjustment and do not enter into later adjustments made to the antenna. The complete antenna is resonated to each amateur band by placing a single-turn coil between the base of the vertical radiator and the radial connection and coupling the grid-dip oscillator to the coil. The coaxial line is removed for this test. The lower section of the vertical antenna is adjusted in length for 10-meter resonance at about 28.7 MHz, followed by adjustment of the center section for resonance at 21.2 MHz. The last adjustment is to the top section for resonance at about 14.2 MHz.

It must be remembered that trap, or other multifrequency antennas are capable of radiating harmonics of the transmitter that may be coupled to them via the transmission line. It is well to check for harmonic radiation with a nearby radio amateur. If such harmonics are noted, an antenna tuner similar to the one described later in this chapter should be added to the installation to reduce unwanted harmonics to a minimum.

The Trap Dipole The trap principle discussed in Chapter 22 may be applied to dipoles as well as to vertical antennas.

Shown in figure 30 are designs for trap dipoles for various amateur bands. For portable or Field Day use, the antennas may be fed directly with either 50- or 72-ohm coaxial line or 72-ohm TV-type ribbon line. For fixed station use, insertion of a balun between the antenna and the coaxial transmission line is recommended. A 20- and 15-meter trap is shown in figure 31. It is designed to be left unprotected and is water-resistant. If desired, it may be covered with a plastic "overcoat" made from a section of a flexible squeeze bottle, such as bleach or laundry soap containers.

Operational bandwidth on the lower-frequency band is somewhat less than that of a comparable dipole, since a portion of the antenna is wound up in the trap element and does not radiate. Typical bandwidth for an 80- and 40-meter dipole, as measured between the 2/1 SWR points on the transmission line is: 80 meters, 180 kHz; 40 meters, 250 kHz.

Operational bandwidth of the 40- and 20-meter antenna is typically: 40 meters,

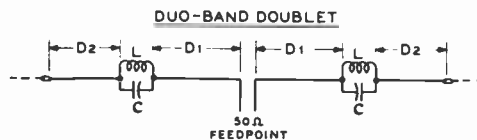

BANDS	D1	D2	L(μH)	C(PF)	F _R
80-40	32' 0"	22' 0"	8.2	60	6.95
40-20	18' 8"	10' 8"	4.7	25	13.8
20-15	10' 5"	3' 7 1/2"	2.9	20	20.7
15-10	8' 0"	1' 11"	1.65	20	27.8

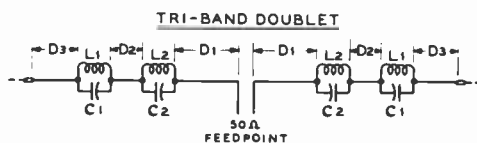

BAND	D1	D2	D3	L1(μH)	C1(PF)	L2(μH)	C2(PF)
20-15-10	8' 0"	1' 10"	2' 9"	2.9	20	1.65	20

Figure 30

MULTIBAND TRAP DOUBLETS

Trap doublet dimensions for duoband and triband antennas. Traps are assembled in the manner shown in figure 31, and antenna dimensions are based on an over-all trap length of two inches. Highest-band resonant frequency may be varied by changing dimension D₁. Lower band is also affected and dimension D₂ must be adjusted to compensate for change in D₁. Sequence of adjustment, then, is D₁, D₂, and D₃. Dimensions shown are for center-of-band resonance. Parallel-tuned traps are adjusted to trap frequency (f_r) outside low-frequency end of band. Trap doublet is preferably fed with balun and 50-ohm transmission line.

300 kHz; 20 meters, 350 kHz. In addition, the antenna may be operated over the lower 1 MHz of the 10-meter band with an SWR figure of less than 1.5/1.

Data is also given in figure 30 for a tri-band doublet covering the 20-, 15-, and 10-meter amateur bands. Operational bandwidth is sufficient to cover all the included bands with a maximum SWR figure at the band edges of less than 2/1 on the transmission line. As with any antenna configuration, bandwidth and minimum SWR indication are a function of the height of the antenna above the ground.

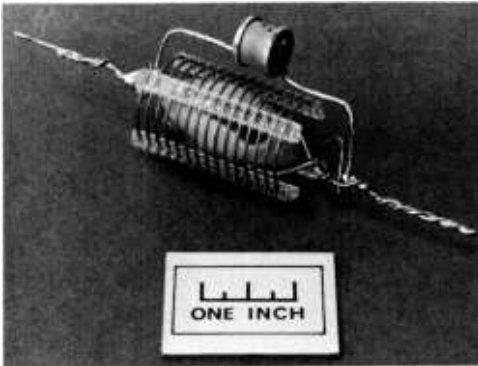

Figure 31

TRAP CONSTRUCTION

Fifteen-meter trap is shown here. Trap is designed for power level of 500 watts, PEP. Trap is built around strain insulator which removes pull of antenna from coil and capacitor. Capacitor is Centralab 853A-20Z (20 pf) and coil is $14\frac{1}{2}$ turns #16, 1" diameter and 2" long (8 turns per inch), Air-Dux 808T. Trap is about 2" long with $1\frac{1}{2}$ " leads. Before placement in the antenna, it is grid-dipped to 20.7 MHz on the bench and adjusted to frequency by removal or addition of a fraction of a turn. Traps for other bands are constructed in similar manner. For 2 kW PEP level, coil should be #12 wire, about 2" diameter, and capacitor should be Centralab type 8505.

21-8 Matching Nonresonant Lines to the Antenna

While ribbon or tubular molded 300-ohm line is often used in vhf antenna installations, coaxial line is universally used in h-f antenna systems and also into the lower portion of the vhf spectrum. Open-wire lines are occasionally used for portable installations or for fixed antenna arrays, but even these are usually matched to a coaxial transmission line for ultimate connection to the transmitting equipment.

These transmission systems generally require some sort of matching device to make an efficient transition from the characteristic impedance of the line to the radiation resistance value of the antenna, otherwise severe standing waves can occur on the transmission line system.

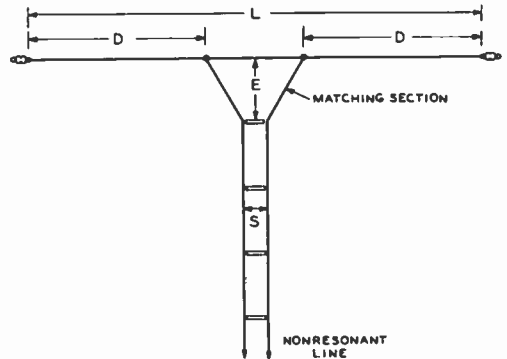

Figure 32

THE DELTA-MATCHED DIPOLE ANTENNA

The dimensions for the portions of the antenna are given in the text.

Standing Waves As was discussed earlier, standing waves on the antenna transmission line, in the transmitting case, are a result of reflection from the point where the feed line joins the antenna system. The magnitude of the standing waves is determined by the degree of mismatch between the characteristic impedance of the transmission line and the input impedance of the antenna system. When the feed-point impedance of the antenna is resistive and of the same value as the characteristic impedance of the feed line, standing waves will not exist on the feeder. It may be well to repeat at this time that there is no adjustment which can be made at the transmitter end of the feed line which will change the magnitude of the standing waves on the antenna transmission line.

Delta-Matched Antenna System The *delta-type matched-impedance antenna system* is shown in figure 32. The impedance of the transmission line is transformed gradually into a higher value by the fanned-out Y portion of the feeders, and the Y portion is tapped on the antenna at points where the Y portion is a compromise between the impedance at the antenna and the impedance of the unfanned portion of the line.

The constants of the system are rather critical, and the antenna must resonate at the operating frequency in order to minimize standing waves on the line. Some slight

readjustment of the taps on the antenna is desirable, if appreciable standing waves persist in appearing on the line.

The constants for a doublet are determined by the following formulas:

$$L_{\text{feet}} = \frac{467.4}{F_{\text{MHz}}}$$

$$D_{\text{feet}} = \frac{175}{F_{\text{MHz}}}$$

$$E_{\text{feet}} = \frac{147.6}{F_{\text{MHz}}}$$

where,

L is antenna length,

D is the distance in from each end at which the Y taps on,

E is the height of the Y section.

Since these constants are correct only for a 600-ohm transmission line, the spacing S of the line must be approximately 75 times the diameter of the wire used in the transmission line. For No. 14 wire, the spacing will be slightly less than 5 inches. This system should never be used on either its even or odd harmonics, as entirely different constants are required when more than a single half wavelength appears on the radiating portion of the system.

Multiwire Doublets When a doublet antenna or the driven element in an array consists of more than one wire or tubing conductor the radiation resistance of the antenna or array is increased slightly as a result of the increase in the effective diameter of the element. Further, if one wire of such a radiator is split, as shown in figure 33, the effective *feed-point* resistance of the antenna or array will be increased by a factor of N^2 where N is equal to the number of conductors, all in parallel, of the same diameter in the array. Thus if there are two conductors of the same diameter in the driven element or the antenna the feed-point resistance will be multiplied by 2^2 , or 4. If the antenna has a radiation resistance of 75 ohms its feed-point resistance will be 300 ohms. This is the case of the conventional *folded dipole* as shown in figure 33B.

If three wires are used in the driven radiator the feed-point resistance is increased by a factor of 9; if four wires are used the

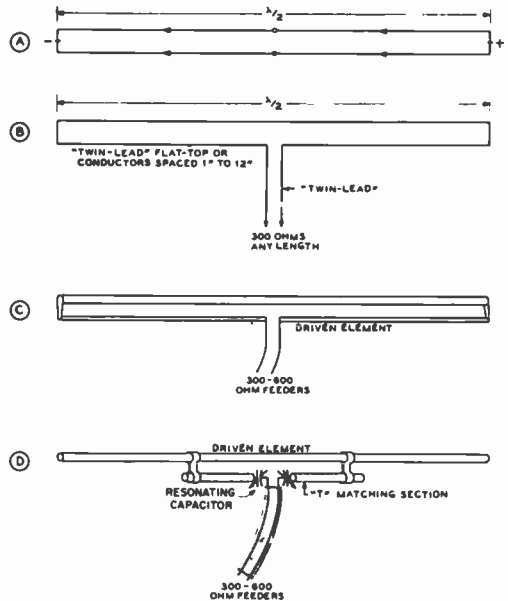

Figure 33

FOLDED-ELEMENT MATCHING SYSTEMS

Drawing A above shows a half-wave made up of two parallel wires. If one of the wires is broken as in B and the feeder connected, the feed-point impedance is multiplied by four; such an antenna is commonly called a "folded doublet." The feed-point impedance for a simple half-wave doublet fed in this manner is approximately 300 ohms, depending on antenna height. Drawing C shows how the feed-point impedance can be multiplied by a factor greater than four by making the half of the element that is broken smaller in diameter than the unbroken half. An extension of the principles of B and C is the arrangement shown at D where the section into which the feeders are connected is considerably shorter than the driven element. This system is most convenient when the driven element is too long (such as for a 28- or 14-MHz array) for a convenient mechanical arrangement of the system shown at C.

impedance is increased by a factor of 16, etc. In certain cases when feeding a parasitic array it is desirable to have an impedance step up different from the value of 4:1 obtained with two elements of the same diameter and 9:1 with three elements of the same diameter. Intermediate values of impedance step up may be obtained by using two elements of different diameter for the complete driven element as shown in figure 33C. If the conductor that is broken for the feeder is of *smaller* diameter than the

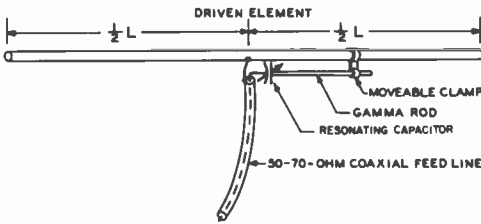

Figure 34

THE GAMMA MATCH FOR CONNECTING AN UNBALANCED COAXIAL LINE TO A BALANCED DRIVEN ELEMENT

other conductor of the radiator, the impedance step up will be *greater* than 4:1. On the other hand if the *larger* of the two elements is broken for the feeder the impedance step up will be *less* than 4:1.

The "T" Match A method of matching a balanced low-impedance transmission line to the driven element of a parasitic array is the *T match* illustrated in figure 33D. This method is an adaptation of the multiwire doublet principle which is more practical for lower-frequency parasitic arrays such as those for use on the 14- and 28-MHz bands. In the system a section of tubing of approximately one-quarter the diameter of the driven element is spaced about four inches below the driven element by means of clamps which hold the T-section mechanically and which make electrical connection to the driven element. The length of the T-section is normally between 15 and 30 inches each side of the center of the dipole for transmission lines of 300 to 600 ohms impedance, assuming 28-MHz operation. In series with each leg of the T-section and the transmission line is a series resonating capacitor. These two capacitors tune out the reactance of the T-section. If they are not used, the T-section will detune the dipole when the T-section is attached to it. The two capacitors may be ganged together, and once adjusted for minimum detuning action, they may be locked. A suitable housing should be devised to protect these capacitors from the weather. Additional information on the adjustment of the T-match is given in the chapter covering rotary beam antennas.

The Gamma Match An unbalanced version of the T-match may be used to feed a dipole from an unbalanced coaxial line. Such a device is called a *Gamma match*, and is illustrated in figure 34.

The length of the Gamma rod and the spacing of it from the dipole determine the impedance level at the transmission line end of the rod. The series capacitor is used to tune out the reactance introduced into the system by the Gamma rod. The adjustment of the Gamma match is discussed in the chapter covering rotary beam antennas.

Matching Stubs By connecting a resonant section of transmission line (called a *matching stub*) to either a voltage or current loop and attaching parallel-wire nonresonant feeders to the resonant stub at a suitable voltage (impedance) point, standing waves on the line may be virtually eliminated. The stub is made to serve as an autotransformer. Stubs are particularly adapted to matching an open line to certain directional arrays, as will be described later.

Voltage Feed When the stub attaches to the antenna at a voltage loop, the stub should be a quarter wavelength long electrically, and be shorted at the bottom end. The stub can be resonated by sliding the shorting bar up and down before the nonresonant feeders are attached to the stub, the antenna being shock-excited from a separate radiator during the process. Slight errors in the length of the radiator can be compensated for by adjustment of the stub if both sides of the stub are connected to the radiator in a symmetrical manner. Where only one side of the stub connects to the radiating system, as in the zepp and in certain antenna arrays, the radiator length must be exactly right in order to prevent excessive unbalance in the untuned line.

Current Feed When a stub is used to current-feed a radiator, the stub should either be left *open* at the bottom end instead of shorted, or else made a *half wave* long. The open stub should be resonated in the same manner as the shorted stub before attaching the transmission line; however, in this case, it is necessary to prune the stub to resonance, as there is no shorting bar.

Sometimes it is handy to have a stub hang from the radiator to a point that can be reached from the ground, in order to facilitate adjustment of the position of the transmission-line attachment. For this reason, a quarter-wave stub is sometimes made three-quarters wavelength long at the higher frequencies, in order to bring the bottom nearer the ground. Operation with any *odd* number of quarter waves is the same as for a quarter-wave stub.

Stub Length (Electrical)	Current-Fed Radiator	Voltage-Fed Radiator
$\frac{1}{4}$ - $\frac{3}{4}$ - $1\frac{1}{4}$ -etc. wavelengths	Open Stub	Shorted Stub
$\frac{1}{2}$ - 1 - $1\frac{1}{2}$ - 2 -etc. wavelengths	Shorted Stub	Open Stub

Any number of half waves can be added to either a quarter-wave stub or a half-wave stub without disturbing the operation, though losses and frequency sensitivity will be lowest if the shortest usable stub is employed (see chart).

Linear R-F Transformers A resonant quarter-wave line has the unusual property of acting much as a transformer. Let us take, for example, a section consisting of No. 12 wire spaced 6 inches, which happens to have a surge impedance of 600 ohms. Let the far end be terminated with a pure resistance, and let the near end be fed with radio-frequency energy at the frequency for which the line is a *quarter wavelength* long. If an impedance measuring set is used to measure the impedance at the near end while the impedance at the far end is varied, an interesting relationship between the 600-ohm characteristic surge impedance of this particular quarter-wave matching line, and the impedance at the ends will be discovered.

When the impedance at the far end of the line is the same as the characteristic surge impedance of the line itself (600 ohms), the impedance measured at the near end of the quarter-wave line will also be found to be 600 ohms.

Under these conditions, the line would not have any standing waves on it, since it is terminated in its characteristic impedance. Now, let the resistance at the far end

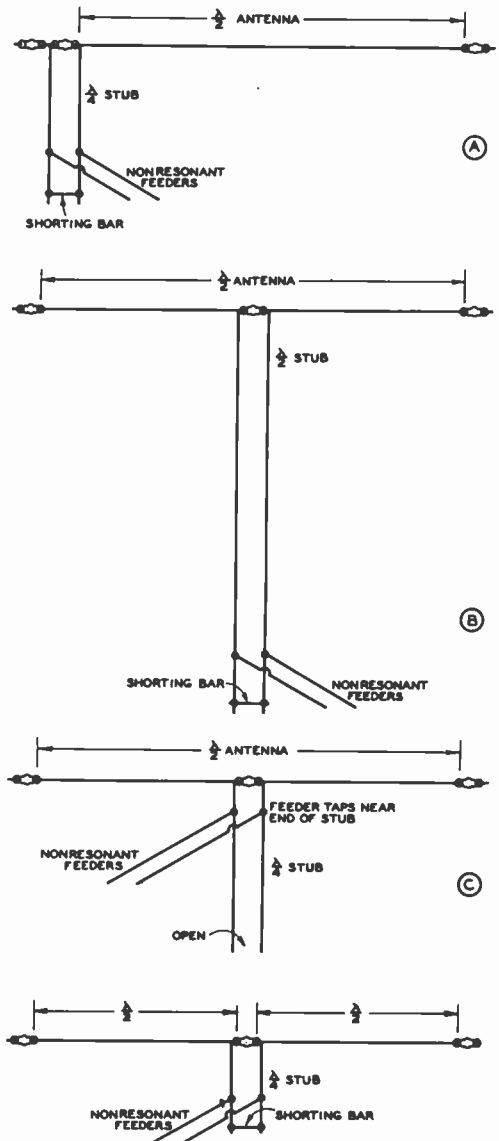

Figure 35

MATCHING STUB APPLICATIONS

An end-fed half-wave antenna with a quarter-wave shorted stub is shown at A. B shows the use of a half-wave shorted stub to feed a relatively low impedance point such as the center of the driven element of a parasitic array, or the center of a half-wave dipole. The use of an open-ended quarter-wave stub to feed a low impedance is illustrated at C. D shows the conventional use of a shorted quarter-wave stub to voltage-feed two half-wave antennas with a 180° phase difference.

of the line be doubled, or changed to 1200 ohms. The impedance measured at the near end of the line will be found to have been cut in half (to 300 ohms). If the resistance at the far end is made half the original value of 600 ohms or 300 ohms, the impedance at the near end doubles the original value of 600 ohms, and becomes 1200 ohms. As one resistance goes up, the other goes down proportionately.

It will always be found that the characteristic surge impedance of the quarter-wave matching line is the geometric mean between the impedance at both ends. This relationship is shown by the following formula:

$$Z_{MS} = \sqrt{Z_A Z_L}$$

where,

- Z_{MS} equals impedance of matching section,
- Z_A equals antenna resistance,
- Z_L equals line impedance.

Quarter-Wave Matching Transformers The impedance inverting characteristic of a quarter-wave section of transmission line is widely used by making such a section of line act as a *quarter-wave transformer*. The quarter-wave transformer may be used in a wide number of applications wherever a transformer is required to match two impedances whose geometric mean is somewhere between perhaps 25 and 750 ohms when transmission-line sections can be used. Paralleled coaxial lines may be used to obtain the lowest impedance mentioned, and open-wire lines composed of small conductors spaced a moderate distance may be used to obtain the higher impedance. A short list of impedances, which may be matched by quarter-wave sections of transmission line having specified impedances, follows.

Load or Ant. Impedance ↓	← Feed-Line Impedance			
	300	480	600	
20	77	98	110	Quarter-Wave Transformer Impedance
30	95	120	134	
50	110	139	155	
75	150	190	212	
100	173	220	245	

Q-Section Feed System The standard form of *Q-section* feed to a doublet is shown in figure 36. An impedance match is obtained by utilizing a matching section, the surge impedance of which is the geometric mean between the transmission-line surge impedance and the radiation resistance of the radiator. A sufficiently good match usually can be obtained by either designing or adjusting the matching section for a dipole to have a surge impedance that is the geometric mean between the line impedance and 72 ohms, the latter being the theoretical radiation resistance of a half-wave doublet either infinitely high or a half wave above a perfect ground.

Though the radiation resistance may depart somewhat from 72 ohms under actual conditions, satisfactory results will be obtained with this assumed value, so long as the dipole radiator is more than a quarter wave above effective earth, and reasonably in the clear.

A Q-matched system can be adjusted precisely, if desired, by constructing a

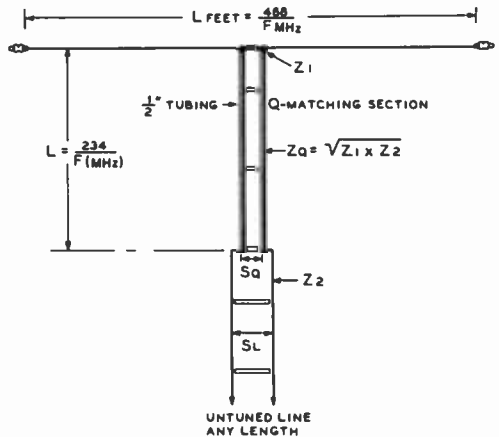

Figure 36
HALF-WAVE RADIATOR FED BY "Q BARS"

The Q matching section is simply a quarter-wave transformer whose impedance is equal to the geometric mean between the impedance at the center of the antenna and the impedance of the transmission line to be used to feed the bottom of the transformer. The transformer may be made up of parallel tubing, "ribbon" line, or any other type of transmission line which has the correct value of impedance.

matching section to the calculated dimensions with provision for varying the spacing of the Q-section conductors slightly, after the untuned line has been checked for standing waves.

Center to Center Spacing in Inches	Impedance in Ohms for 1/2" Diameters	Impedance in Ohms for 1/4" Diameters
1.0	170	250
1.25	188	277
1.5	207	298
1.75	225	318
2.0	248	335

PARALLEL TUBING SURGE IMPEDANCE FOR MATCHING SECTIONS

The Collins Transmission Line Matching System The advantages of unbalanced output networks for transmitters are numerous; however this output system becomes awkward when it is desired to feed an antenna system utilizing a balanced input. For some time the *Collins Radio Co.* has been using a balun and tapered-line system for matching a coaxial-output transmitter to an open-wire balanced transmission line. Illustrated in figure 37 is one type of matching system which is proving satisfactory over a 4:1 frequency range. Z_1 is the transmitter end of the system and may be any length of 52-ohm coaxial cable. Z_2 is one-quarter wavelength long at the *midfrequency* of the range to be covered and is made of 75-ohm coaxial cable. Z_A is a quarter-wavelength shorted section of cable at the midfrequency. Z_0 (Z_A and Z_2) forms a 200-ohm quarter-wave section. The Z_A section is formed of a conductor of the same diameter as Z_2 . The difference in length between Z_A and Z_2 is accounted for by the fact that Z_2 is a coaxial conductor with a solid dielectric, whereas the dielectric for Z_0 is air. Z_3 is one-quarter wavelength long at the *midfrequency* and has an impedance of 123 ohms. Z_4 is one-quarter wavelength long at the *midfrequency* and has an impedance of 224 ohms. Z_5 is the balanced line to be matched (in this case 300 ohms) and may be any length.

Other system parameters for different output and input impedances may be calculated from the following:

$$r = \sqrt{\frac{N Z_{out}}{Z_{in}}}$$

where,

N is the number of sections. In the above case:

$$r = \sqrt[3]{\frac{Z_5}{Z_1}}$$

Impedance between sections, as Z_{2-3} , is r times the preceding section. $Z_{2-3} = r \times Z_1$, and $Z_{3-4} = r \times Z_{2-3}$.

Midfrequency (m):

$$m = \frac{F_1 + F_2}{2}$$

For 40-20-10 meters $= \frac{7 + 30}{2} = 18.5$ MHz

and one-quarter wavelength = 12 feet.

For 20-10-6 meters $= \frac{14 + 54}{2} = 34$ MHz

and one-quarter wavelength = 5.5 feet.

The impedance of the sections are:

$$Z_2 = \sqrt{Z_1 \times Z_{2-3}}$$

$$Z_3 = \sqrt{Z_{2-3} \times Z_{3-4}}$$

$$Z_4 = \sqrt{Z_{3-4} \times Z_5}$$

$$Z_0 = \frac{2}{3} \times Z_5$$

Generally, the larger the number of taper sections the greater will be the bandwidth of the system.

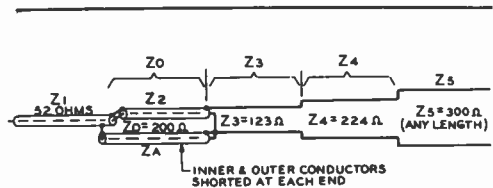

Figure 37

COLLINS TRANSMISSION-LINE MATCHING SYSTEM

A wide-band system for matching a 52-ohm coaxial line to a balanced 300-ohm line over a 4:1 frequency range.

The Inducto-Match The driven element of a beam antenna or a simple dipole antenna may form a portion of a network whose input impedance is close to 50 ohms over a small frequency range (figure 38). It is necessary that the radiation resistance of the element be less than the impedance of the transmission line, and this condition is met under most circumstances.

The radiation resistance of the antenna element is made to appear as a capacitive reactance at the driving point by shortening the element past the normal resonant length. The inductive portion of the network takes the form of a hairpin or coil placed across the terminals of the driven element. The L/C ratio of the combination determines the transformation ratio of the network when the LC product is resonant at the center frequency of antenna operation. Inductance of the hairpin or coil is best determined by experiment. Measurements made at 14 MHz, point to a shortening effect of about six inches in the over-all length of the driven element, and an inductance of about $0.5 \mu\text{H}$ in the hairpin. Complete information on this compact and efficient matching system is given in the *Beam Antenna Handbook*,

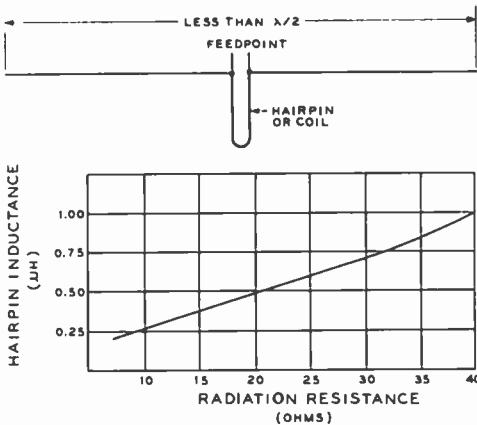

Figure 38

THE INDUCTO-MATCH

Dipole element acts as matching transformer by placing inductor at the center and shortening element to provide capacitive reactance across feedpoint. Typical three-element Yagi antenna has feedpoint impedance of about 20 ohms and calls for $0.5 \mu\text{H}$ inductor. Impedance match is made by varying inductor and length of dipole.

published by Radio Publications, Inc., Wilton, Conn.

21-9 Antenna Supports

The foregoing portion of this chapter has been concerned primarily with the *electrical* characteristics and considerations of antennas. Some of the physical aspects and mechanical problems incident to the actual erection of antennas and arrays will be discussed in the following section.

Up to 30 feet, there is little point in using mast-type antenna supports unless guy wires either must be eliminated or kept to a minimum. While a little more difficult to erect, because of their floppy nature, fabricated wood poles of the type to be described will be just as satisfactory as more rigid types, *provided* many guy wires are used.

Rather expensive when purchased through the regular channels, 40- and 50-foot telephone poles sometimes can be obtained quite reasonably. In the latter case, they are hard to beat, inasmuch as they require no guying if set in the ground six feet (standard depth), and the resultant pull in any lateral direction is not in excess of a hundred pounds or so.

For heights of 80 to 100 feet, either three- or four-sided lattice-type masts are most practical. They can be made self-supporting, but a few guys will enable one to use a smaller cross section without danger from high winds. The torque exerted on the base of a high self-supporting mast is terrific during a strong wind.

The "A-Frame" Mast Figures 39A and 39B show the standard method of construction of the A-

frame type of mast. This type of mast is quite frequently used since there is only a moderate amount of work involved in the construction of the assembly and since the material cost is relatively small. The three pieces of selected 2 by 2 are first set up on three sawhorses or boxes and the holes drilled for the three $\frac{1}{4}$ -inch bolts through the center of the assembly. Then the base legs are spread out to about 6 feet and the bottom braces installed. Finally the upper

Figure 39

TWO SIMPLE WOOD MASTS

Shown at A is the method of assembly, and at B is the completed structure, of the conventional "A-frame" antenna mast. At C is shown a structure which is heavier but more stable than the A-frame for heights above about 40 feet.

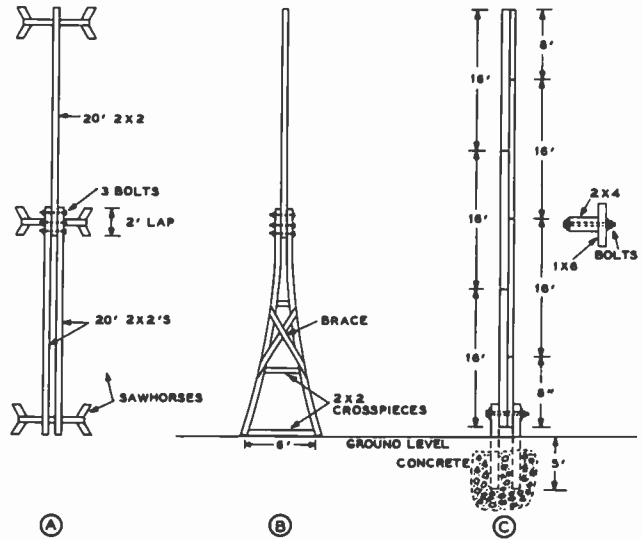

braces and the cross pieces are installed and the assembly given several coats of good-quality paint as a protection against weathering.

Figure 39C shows another common type of mast which is made up of sections of 2 × 4 placed end-to-end with stiffening sections of 1 by 6 bolted to the edge of the 2 by 4 section. Both types of mast will require a set of top guys and another set of guys about one-third of the way down from the top. Two guys spaced about 90 to 100 degrees and pulling against the load of the antenna will normally be adequate for the top guys. Three guys are usually used at the lower level, with one directly behind the load of the antenna and two more spaced 120 degrees from the rear guy.

Raising the mast is made much easier if a gin pole about 20 feet high is installed about 30 or 40 feet to the rear of the direction in which the antenna is to be raised. A line from a pulley on the top of the gin pole is then run to the top of the pole to be raised. The gin pole comes into play when the center of the mast has been raised 10 to 20 feet above the ground and an additional elevated pull is required to keep the top of the mast coming up as the center is raised further above ground.

Using TV Masts Steel tubing masts of the telescoping variety are

widely available at a moderate price for use in supporting television antenna arrays. These masts usually consist of several 10-foot lengths of electrical metal tubing (EMT) of sizes such that the sections will telescope. The 30- and 40-foot lengths are well suited as masts for supporting antennas and arrays of the type used on the amateur bands. The masts are constructed in such a manner that the bottom 10-foot length may be guyed permanently before the other sections are raised. Then the upper sections may be extended, beginning with the top-mast section, until the mast is at full length (provided a strong wind is not blowing) following which all the guys may be anchored. It is important that there be no load on the top of the mast when the "vertical" raising method is to be employed.

Guy Wires Guy wires should never be pulled taut; a *small* amount of slack is desirable. Galvanized wire, somewhat heavier than seems sufficient for the job, should be used. The heavier wire is a little harder to handle, but costs only a little more and takes longer to rust through. Care should be taken to make sure that no kinks exist when the pole or tower is ready for erection, as the wire will be greatly weakened at such points if a kink is pulled tight, even if it is later straightened.

If "dead men" are used for the guy wire terminations, the wire or rod reaching from the dead men to the surface should be of nonrusting material, such as brass, or given a heavy coating of asphalt or other protective substance to prevent destructive action by the damp soil. Galvanized iron wire will last only a short time when buried in moist soil.

Only strain-type (compression) insulators should be used for guy wires. Regular ones might be sufficiently strong for the job, but it is not worth taking chances, and egg-type strain halyard insulators are no more expensive.

Only a brass or bronze pulley should be used for the halyard, as a high pole with a rusted pulley is truly a sad affair. The bearing of the pulley should be given a few drops of heavy machine oil before the pole or tower is raised. The halyard itself should be of good material, preferably waterproofed. Hemp rope of good quality is better than window sash cord from several standpoints, and is less expensive. Soaking it thoroughly in engine oil of medium viscosity, and then wiping it off with a rag, will not only extend its life but minimize shrinkage in wet weather. Because of the difficulty of replacing a broken halyard it is a good idea to replace it periodically, without waiting for it to show excessive deterioration.

It is an excellent idea to tie both ends of the halyard line together in the manner of a flag-pole line. Then the antenna is tied onto the place where the two ends of the halyard are joined. This procedure of making the halyard into a loop prevents losing the top end of the halyard should the antenna break near the end, and it also prevents losing the halyard completely should the end of the halyard carelessly be allowed to go free and be pulled through the pulley at the top of the mast by the antenna load. A somewhat longer piece of line is required but the insurance is well worth the cost of the additional length of rope.

Trees as Supports Often a tall tree can be used to support one end of an antenna, but one should not attempt to attach anything to the top, as the swaying of the top of the tree during a heavy wind will complicate matters.

If a tree is utilized for support, provision should be made for keeping the antenna taut without submitting it to the possibility of being severed during a heavy wind. This can be done by the simple expedient of using a pulley and halyard, with weights attached to the lower end of the halyard to keep the antenna taut. Only enough weight to avoid excessive sag in the antenna should be tied to the halyard, as the continual swaying of the tree submits the pulley and halyard to considerable wear.

Painting The life of a wood mast or pole can be increased several hundred percent by protecting it from the elements with a coat or two of paint. And, of course, the appearance is greatly enhanced. The wood should first be given a primer coat of flat white outside house paint, which can be thinned down a bit to advantage with second-grade linseed oil. For the second coat, which should not be applied until the first is thoroughly dry, *aluminum paint* is not only the best from a preservative standpoint, but looks very well. This type of paint, when purchased in quantities, is considerably cheaper than might be gathered from the price asked for quarter-pint cans.

Portions of posts or poles below the surface of the soil can be protected from termites and moisture by painting with *cresote*. While not so strong initially, redwood will deteriorate much more slowly when buried than will the white woods, such as pine.

Antenna Wire The antenna or array itself presents no special problem. A few considerations should be borne in mind, however. For instance, soft-drawn copper should not be used, as even a short span will stretch several percent after whipping around in the wind a few weeks, thus affecting the resonant frequency. Enameled copper wire, as ordinarily available at radio stores, is usually soft-drawn, but by tying one end to some object such as a telephone pole and the other to the frame of an auto, a few husky tugs can be given and the wire, after stretching a bit, is equivalent to hard-drawn.

Where a long span of wire is required, or where heavy insulators in the center of

the span result in considerable tension, copper-clad steel wire is somewhat better than hard-drawn copper. It is a bit more expensive, though the cost is far from prohibitive. The use of such wire, in conjunction with strain insulators is advisable where the antenna would endanger persons or property should it break.

For transmission lines and tuning stubs steel-core or hard-drawn wire will prove awkward to handle, and soft-drawn copper should, therefore, be used. If the line is long, the strain can be eased by supporting it at several points.

More important from an electrical standpoint than the actual size of wire used is the soldering of joints, especially at current loops in an antenna of low radiation resistance. In fact, it is good practice to solder *all* joints, thus ensuring quiet operation when the antenna is used for receiving.

Insulation A question that often arises is that of insulation. It depends, of course, on the r-f voltage at the point at which the insulator is placed. The r-f voltage, in turn, depends on the distance from a current node, and the radiation resistance of the antenna. Radiators having low radiation resistance have very high voltage at the voltage loops; consequently, better than usual insulation is advisable at those points.

Open-wire lines operated as nonresonant lines have little voltage across them; hence the most inexpensive ceramic types are sufficiently good electrically. With tuned lines, the voltage depends on the amplitude of the standing waves. If they are very great, the voltage will reach high values at the voltage loops, and the best spacers available are none too good. At the current loops the voltage is quite low, and almost anything will suffice.

When insulators are subject to very high r-f voltages, they should be cleaned occasionally if in the vicinity of sea water or smoke. Salt scum and soot are not readily dislodged by rain, and when the coating becomes heavy enough, the efficiency of the insulators is greatly impaired.

If a very pretentious installation is to be made, it is wise to check up on both Underwriter's rules and local ordinances which might be applicable. If you live anywhere

near an airport, and are contemplating a tall pole, it is best to investigate possible regulations and ordinances pertaining to towers in the district, before starting construction.

21-10 Coupling to the Antenna System

When coupling an antenna feed system to a transmitter the most important considerations are as follows: (1) means should be provided for varying the load on the amplifier; (2) the load presented to the final amplifier should be resistive (nonreactive) in character; and (3) means should be provided to reduce harmonic coupling between the final amplifier plate tank circuit and the antenna or antenna transmission line to an *extremely low* value.

The Transmitter-Loading Problem The problem of coupling the power output of a high-frequency or vhf transmitter to the radiating portion of the antenna system has been complicated by the virtual necessity for eliminating interference to TV reception. However, the TVI-elimination portion of the problem may *always* be accomplished by adequate shielding of the transmitter, by filtering of the control and power leads which enter the transmitter enclosure, and by the inclusion of a harmonic-attenuating filter between the output of the transmitter and the antenna system.

Although TVI may be eliminated through inclusion of a filter between the output of a shielded transmitter and the antenna system, the fact that such a filter should be included in the link between transmitter and antenna makes it necessary that the transmitter-loading problem be re-evaluated in terms of the necessity for inclusion of such a filter.

Harmonic-attenuating filters must be operated at an impedance level which is close to their design value; therefore they must operate *into* a resistive termination substantially equal to the characteristic impedance of the filter. If such filters are operated into an impedance which is not resistive and approximately equal to their characteristic impedance: (1) the capacitors used in the filter sections will be subjected to high peak

voltages and may be damaged, (2) the harmonic-attenuating properties of the filter will be decreased, and (3) the impedance at the input end of the filter will be different from that seen by the filter at the load end (except in the case of the half-wave type of filter). It is therefore important that the filter be included in the transmitter-to-antenna circuit at a point where the impedance is close to the nominal value of the filter, and at a point where this impedance is likely to remain fairly constant with variations in frequency.

Block Diagrams of Transmitter-to-Antenna Coupling Systems

There are two basic arrangements which include all the provisions required in the

transmitter-to-antenna coupling system, and which permit the harmonic-attenuating filter to be placed at a position in the coupling system where it can be operated at an impedance level close to its nominal value. These arrangements are illustrated in block diagram form in figures 40 and 41.

The arrangement of figure 40 is recommended for use with a single-band antenna system, such as a dipole or a rotatable array, wherein an impedance matching system is included within or adjacent to the antenna. The feed line coming down from the antenna system should have a characteristic impedance equal to the nominal impedance of the harmonic filter, and the impedance matching at the antenna should be such that the standing-wave ratio on the antenna feed line is less than 2 to 1 over the range of frequency to be fed to the antenna.

The arrangement of figure 40 is more or less standard for commercially manufactured equipment for amateur and commercial use in the high-frequency and vhf range.

The arrangement of figure 41 merely adds an antenna coupler between the output of the harmonic attenuating filter and the antenna transmission line. The antenna coupler will have some harmonic-attenuating action, but its main function is to transform the impedance at the station end of the antenna transmission line to the nominal value of the harmonic filter. Hence the arrangement of figure 41 is more general than the figure 40 system, since the inclusion of the antenna coupler allows the system to feed an antenna transmission line of any reasonable impedance value, and also without regard to the standing-wave ratio which might exist on the antenna transmission line. Antenna couplers are discussed in a following section.

Output Coupling Adjustment

It will be noticed by reference to both figure 40 and figure 41 that a box

labeled *Coupling Adjustment* is included in the block diagram. Such an element is necessary in the complete system to afford an adjustment in the value of load impedance presented to the tubes in the final amplifier stage of the transmitter. The impedance at the input terminal of the harmonic filter is established by the antenna, through its matching system and the antenna coupler, if used. In any event the impedance at the input terminal of the harmonic filter should be very close to the nominal impedance of the filter. Then the *Coupling Adjustment* provides means for transforming this impedance value to the correct operating value of load impedance which should be presented to the final amplifier stage.

There are two common ways for accomplishing the antenna coupling adjustment, as illustrated in figures 42 and 43. Figure 42

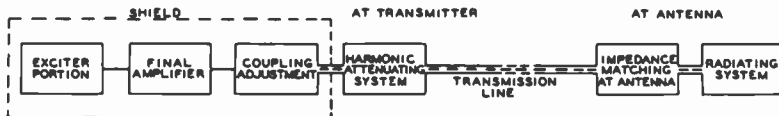

Figure 40

ANTENNA COUPLING SYSTEM

The harmonic suppressing antenna coupling system illustrated above is for use when the antenna transmission line has a low standing-wave ratio, and when the characteristic impedance of the antenna transmission line is the same as the nominal impedance of the low-pass harmonic-attenuating filter.

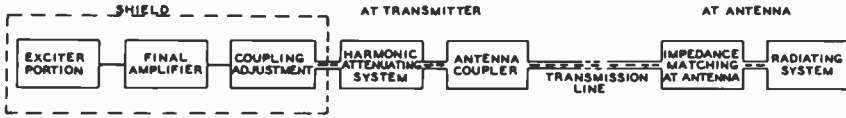

Figure 41

ANTENNA COUPLING SYSTEM

The antenna coupling system illustrated above is for use when the antenna transmission line does not have the same characteristic impedance as the TVI filter, and when the standing-wave ratio on the antenna transmission line may or may not be low.

shows the variable-link arrangement often used in home-constructed equipment, while the pi-network coupling arrangement is illustrated in figure 43. Either method may be used, and each has its advantages.

Variable-Link Coupling

The variable-link method illustrated in figure 42 provides good rejection to subharmonics. For greatest bandwidth of operation of the coupling circuit, the reactance of link coil L and the reactance of link tuning capacitor C should both be between 3 and 4 times the nominal load impedance of the harmonic filter. This is to say that the inductive reactance of coupling link L should be tuned out or resonated by capacitor C, and the operating Q of the LC link circuit should be between 3 and 4. If L and C are made resonant at the center of a band, with a link circuit Q of 3 to 4, and coupling adjustment is made by physical adjustment of L with respect to the final amplifier tank coil, it usually will be possible to operate over an entire amateur band without change in the coupling system. Capacitor C normally may have a low voltage rating, even with a high-power trans-

mitter, due to the low Q and low impedance of the coupling circuit.

Pi-Network Coupling

The pi-network coupling system offers two advantages: (1) a mechanical coupling variation is not required to vary the loading of the final amplifier, and (2) the pi-network (if used with an operating Q of about 10) offers within itself a harmonic attenuation of 30 db or more, in addition to the harmonic attenuation provided by the additional harmonic attenuating filter. Some commercial equipment incorporates an L-network in addition to the pi-network, for accomplishing the impedance transformation in two steps to provide additional harmonic attenuation.

Tuning the Pi-Section Coupler

Tuning a pi-network coupling circuit such as illustrated in figure 43 is accomplished in the following manner: First place a dummy load on the output terminal of the transmitter. Tune C₂ to a capacitance which is large for the band in use, adding suitable additional capacitance by switch S if operation is to be on one of the lower-frequency bands. Apply reduced plate volt-

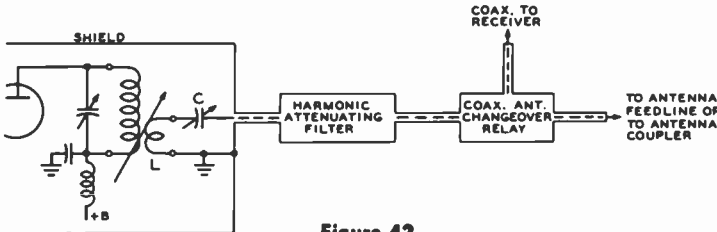

Figure 42

TUNED-LINK OUTPUT CIRCUIT

Capacitor C should be adjusted so as to tune out the inductive reactance of the coupling link, L. Amplifier loading is controlled by varying the coupling between the plate tank of the final amplifier and the antenna link.

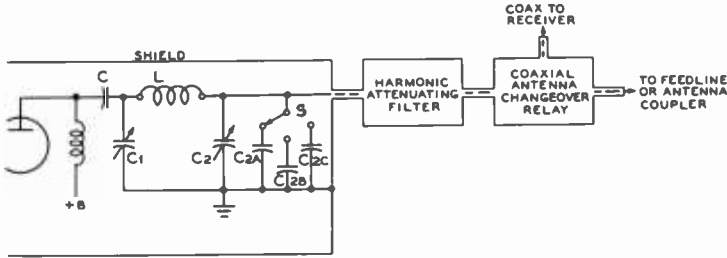

Figure 43

PI-NETWORK ANTENNA COUPLER

The design of pi-network circuits is discussed in Chapter Thirteen. The additional output-end shunting capacitors selected by switch S are for use on the lower frequency ranges. Inductor L may be selected by a tap switch; it may be continuously variable; or plug-in inductors may be used.

age to the stage and dip to resonance with C_1 . It may be necessary to vary the inductance in coil L, but in any event, resonance should be reached with a setting of C_1 which is approximately correct for the desired value of operating Q of the pi-network.

Next, couple the load to the amplifier (through the harmonic filter), apply reduced plate voltage again and dip to resonance with C_1 . If the plate-current dip with load is too low (taking into consideration the reduced plate voltage), decrease the capacitance of C_2 and again dip to resonance, repeating the procedure until the correct value of plate current is obtained with full plate voltage on the stage. There should be a relatively small change required in the setting of C_1 (from the original setting of C_1 without load) if the operating Q of the network is correct and if a large value of impedance transformation is being employed—as would be the case when transforming from the plate impedance of a single-ended output stage down to the 50-ohm impedance of the usual harmonic filter and its subsequent load.

In a pi-network of this type the harmonic attenuation of the section will be adequate when the correct value of C_1 and L are being used and when the resonant dip in C_1 is sharp. If the dip in C_1 is broad, or if the plate current persists in being too high with C_2 at maximum setting, it means that a greater value of capacitance is required at C_2 , assuming that the values of C_1 and L are correct.

21-11 Antenna Couplers

As stated in the previous section, an antenna coupler is not required when the impedance of the antenna transmission line is the same as the nominal impedance of the harmonic filter, and the antenna feed line is being operated with a low standing-wave ratio. However, there are many cases where it is desirable to feed a multiband antenna from the output of the harmonic filter, where a tuned line is being used to feed the antenna, or where a long wire without a separate feed line is to be fed from the output of the harmonic filter. In such cases an antenna coupler is required.

In certain cases when a pi-network is being used at the output of the transmitter, the addition of an antenna coupler will provide sufficient harmonic attenuation. But in all normal cases it is prudent to include a harmonic filter between the output of the transmitter and the antenna coupler.

Function of an Antenna Coupler The function of the antenna coupler is, basically, to transform the impedance of the antenna system being used to the correct value of resistive impedance for the harmonic filter, and hence for the transmitter. Thus the antenna coupler may be used to resonate the feeders or the radiating portion of the antenna system, in addition to its function of impedance transformation.

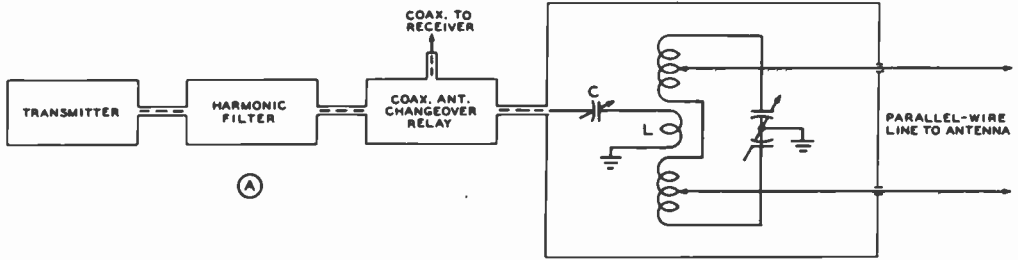

Figure 44

ALTERNATIVE ANTENNA COUPLER CIRCUITS

Plug-in coils, one or two variable capacitors of the split-stator variety, and a system of switches or plugs and jacks may be used in the antenna coupler to accomplish the feeding of different types of antennas and antenna transmission lines from the coaxial input line from the transmitter or from the antenna changeover relay. Link L should be resonated with capacitor C at the operating frequency of the transmitter so that the harmonic filter will operate into a resistive load impedance of the correct nominal value.

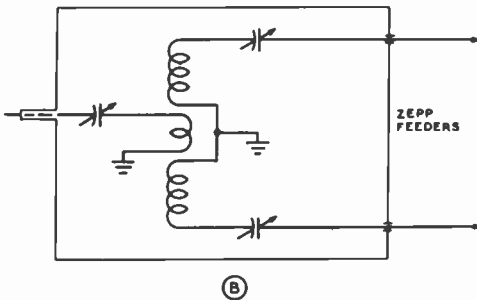

Figure 45

PI-NETWORK ANTENNA COUPLER

An arrangement such as illustrated above is convenient for feeding an end-fed Hertz antenna, or a random length of wire for portable or emergency operation, from the nominal value of impedance of the harmonic filter.

It is important to remember that there is *nothing* that can be done at the antenna coupler which will eliminate standing waves on the antenna transmission line. Standing waves are the result of reflection from the antenna, and the coupler can do nothing about this condition. However, the antenna coupler can resonate the feed line (by introducing a conjugate impedance) in addition to providing an impedance transformation. Thus, a resistive impedance of the correct value can be presented to the harmonic filter, as in figure 41, regardless of any *reasonable* value of standing-wave ratio on the antenna transmission line.

Types of Antenna Couplers

All usual types of antenna couplers fall into two classifications; (1) inductively coupled resonant systems as exemplified by those shown in figure 41, and (2) conductively coupled pi-network systems such as shown in figure 45. The inductively coupled system is convenient for feeding a balanced line from the coaxial output of the usual harmonic filter. The pi-network system is most useful for feeding a length of wire from the output of a transmitter.

Several general methods for using the inductively coupled resonant types of antenna coupler are illustrated in figure 44. The coupling between link coil L and the main tuned circuit need not be variable; in fact it is preferable that the correct link size and placement be determined for the tank coil which will be used for each band, and then that the link be made a portion of the plug-in coil. Capacitor C then can be adjusted to a predetermined value for each

band so that it will resonate with the link coil for that band. The reactance of the link coil (and hence the reactance of the capacitor setting which will resonate the coil) should be about 3 or 4 times the impedance of the transmission line between the antenna coupler and the harmonic filter, so that the link coupling circuit will have an operating Q of 3 or 4.

The pi-network type of antenna coupler, as shown in figure 45, is useful for certain applications, but is primarily useful in feeding a single-wire antenna from a low-impedance transmission line. In such an application the operating Q of the pi-network may be somewhat lower than that of a pi-network in the plate circuit of the final amplifier of a transmitter, as shown in figure 40. An operating Q of 3 or 4 in such an application will be found to be adequate, since harmonic attenuation has been accomplished ahead of the antenna coupler.

An alternative arrangement shown in figure 46 utilizes the antenna-coupling tank circuit only when feeding the coaxial output of the transmitter to the open-wire feed line (or similar multiband antenna) of the 40- and 80-meter antenna. The coaxial lines

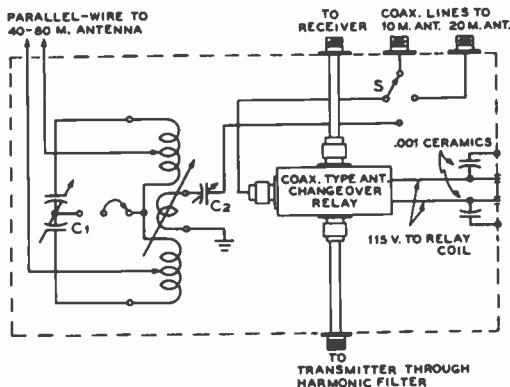

Figure 46

ALTERNATIVE COAXIAL ANTENNA COUPLER

This circuit is recommended for coaxial lines with low SWR used to feed antenna systems such as rotatable beams, and when it is desired to feed open-wire line to some sort of multiband antenna for the lower-frequency ranges. The tuned circuit of the antenna coupler is operative only when using the open-wire feed, and then it is in operation both for transmit and receive.

to the 10-meter beam and to the 20-meter beam would be fed directly from the output of the coaxial antenna-changeover relay through switch S.

21-12 A Single-Wire Antenna Tuner

One of the simplest and least expensive antennas for transmission and reception is the single-wire, end-fed Hertz antenna. When used over a wide range of frequencies, this type of antenna exhibits a very great range of input impedance. At the low-frequency end of the spectrum such an antenna may present a resistive load of less than one ohm to the transmitter, combined with a large positive or negative value of reactance. As the frequency of operation is raised, the resistive load may rise to several thousand ohms (near half-wave resonance) and the reactive component of the load can rapidly change from positive to negative values, or vice-versa.

To provide indication for tuning the network, a radio-frequency bridge (SWR meter) is included to indicate the degree of mismatch (standing-wave ratio) existing at the input to the tuner. All adjustments to the tuner are made with the purpose of reaching unity standing-wave ratio on the coaxial feed system between the tuner and the transmitter.

A Practical Antenna Tuner A simple antenna tuner for use with transmitters of 250 watts power or less is shown in figures 47 through 49. An SWR-bridge circuit is used to indicate tuner resonance. The resistive arm of the bridge consists of ten 10-ohm, 1-watt carbon resistors connected in parallel to form a 1-ohm resistor (R_1). The other pair of bridge arms are capacitive rather than resistive. The bridge detector is a simple r-f voltmeter employing a 1N56 crystal diode and a 0-1 d-c milliammeter. A sensitivity control is incorporated to prevent overloading the meter when power is first applied to the tuner. Final adjustments are made with the sensitivity control at its maximum (clockwise) position. The bridge is balanced when the input impedance of the tuner is 52 ohms

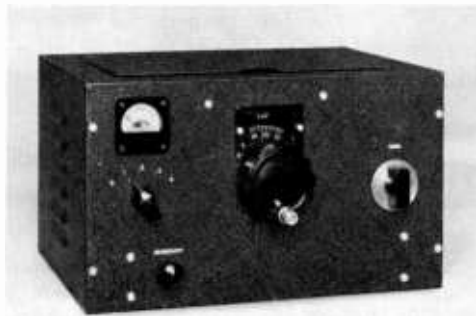
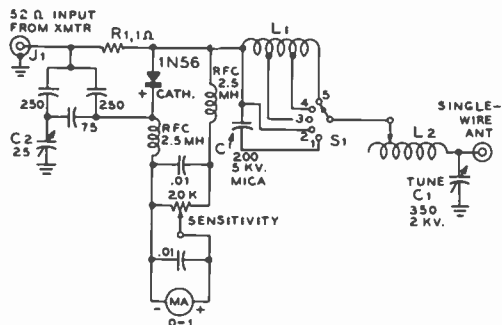

Figure 47

ANTENNA TUNER IS HOUSED IN METAL CABINET 7 INCHES \times 8 INCHES IN SIZE

Inductance switch S_1 and sensitivity control are at left with counter dial for L_1 at center. Output tuning capacitor C_1 is at right. SWR meter is mounted above S_1 .



L1-35 TURNS \times 18, 2" DIA., 3.5" LONG (AIR-DUX) TAP AT 15 T., 27 T., FROM POINT A.
L2-JOHNSON 229-201 VARIABLE INDUCTOR (10 μ H)
C1-JOHNSON 35DE 20
C2-CENTRALAB TYPE 822
J1-TYPE 50-239 RECEPTACLE
R1-TEN 10-OHM 1-WATT CARBON RESISTORS IN PARALLEL. IRC TYPE 87A

Figure 48

SCHEMATIC OF A SINGLE-WIRE ANTENNA TUNER

resistive. This is the condition for maximum energy transfer between transmission line and antenna. The meter is graduated in arbitrary units, since actual SWR value is not required.

Tuner Construction Major parts placement in the tuner is shown in figures 47 and 49. Tapped coil L_1 is mounted on $\frac{1}{2}$ -inch ceramic insulators, and all major components are mounted above deck with the exception of the SWR bridge (figure 50). The components of the bridge are placed below deck, adjacent to the coaxial input plug mounted on the rear apron of the chassis. The ten 10-ohm resistors are soldered to two 1-inch rings made of copper wire as shown in the photograph. The bridge capacitors are attached to this assembly with extremely short leads. The 1N56 crystal mounts at right angles to the resistors to ensure minimum amount of capacitive coupling between the resistors and the detector. The output lead from the bridge passes through a ceramic feedthrough insulator to the top side of the chassis.

Connection to the antenna is made by means of a large feedthrough insulator mounted on the back of the tuner cabinet. This insulator is not visible in the photographs.

Bridge Calibration The SWR bridge must be calibrated for 52-ohm service. This can be done by temporarily disconnecting the lead between the bridge and the antenna tuner and connecting a 2-watt, 52 ohm carbon resistor to the junction of R_1 and the negative terminal of the 1N56 diode. The opposite lead of the carbon resistor is grounded to the chassis of the bridge. A small amount of r-f energy is fed to the input of the bridge until a reading is obtained on the r-f voltmeter. The 25-pf bridge-balancing capacitor C_2 (see figure 50) is then adjusted with a fiber-blade screwdriver until a zero reading is obtained on the meter. The sensitivity control is advanced as the meter null grows, in order to obtain the exact point of bridge balance. When this point is found, the carbon resistor should be removed and the bridge attached to the antenna tuner. The bridge capacitor is sealed with a drop of nail polish to prevent misadjustment.

Tuner Adjustments All tuning adjustments are made to obtain proper transmitter loading with a balanced (zero-meter-reading) bridge condition. The tuner is connected to the transmitter through a random length of 52-ohm

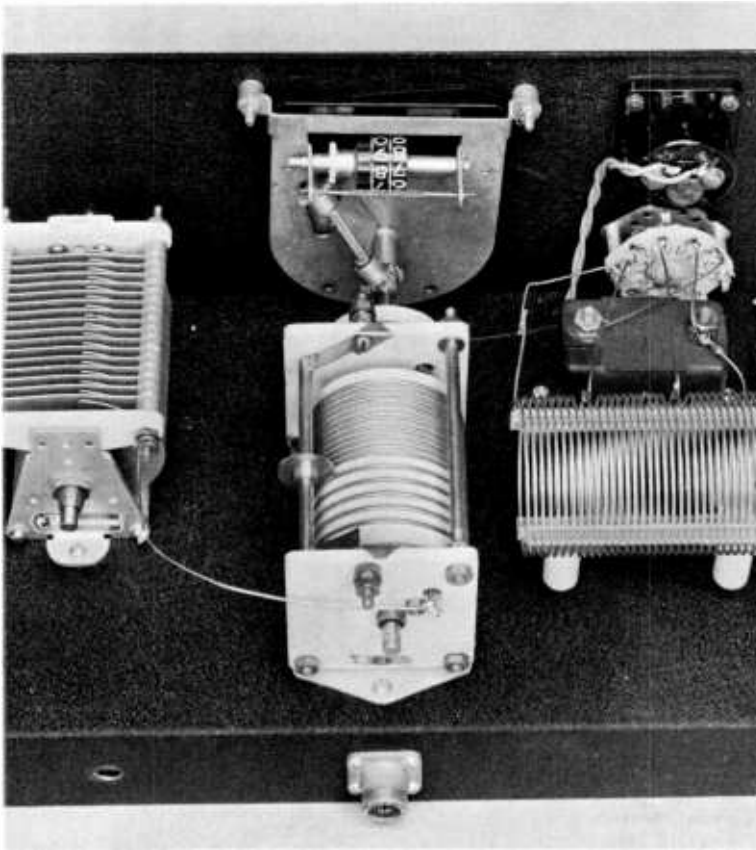

Figure 49
REAR VIEW OF
TUNER SHOWING
PLACEMENT OF
MAJOR
COMPONENTS

Rotary inductor is driven by Johnson 116-208-4 counter dial. Coaxial input receptacle J₁ is mounted directly below rotary inductor.

coaxial line, and the single-wire antenna is attached to the output terminal of the tuner. Transmitter loading controls are set to approximate a 52-ohm termination. The transmitter is turned on (preferably at reduced input) and resonance is established in the amplifier tank circuit. The sensitivity control of the tuner is adjusted to provide near full-scale deflection on the bridge meter. Various settings of S_1 , L_2 , and C_1 should be tried to obtain a reduction of bridge reading. As tuner resonance is approached, the meter reading will decrease and the sensitivity control should be advanced. When the system is in resonance, the meter will read zero. All loading adjustments may then be made with the transmitter controls. The tuner should be readjusted whenever the frequency of the transmitter is varied by an appreciable amount.

21-13 A Tuner for Center-Fed Antenna Systems

Center-fed antennas require a balanced antenna tuner to allow them to be used with transmitters having unbalanced coaxial antenna terminations. Shown in this section is a simple and inexpensive antenna tuner (figure 51) which, when used in conjunction with an SWR meter, will permit center-fed antennas of practically any configuration to be used with modern coaxial-output transmitters.

The unit consists of a parallel-tuned circuit that may be adjusted to a variety of requirements by means of taps on the main coil (L_2 A and B). The number of turns in the circuit are adjusted by means of coil

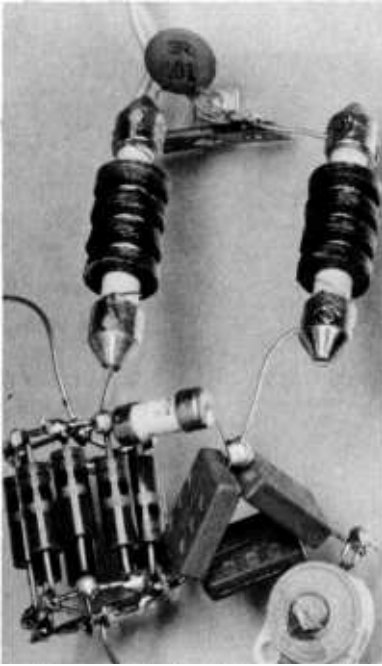

Figure 50

CLOSE-UP OF SWR BRIDGE

Simple SWR bridge is mounted below the chassis of the tuner. Carbon resistors are mounted to two copper rings to form low-inductance one-ohm resistor. Bridge capacitors form triangular configuration for lowest lead inductance. Balancing capacitor C, is at lower right.

taps A and B (figure 52) and the impedance transformation presented to the two-wire feed system is adjusted by means of coil taps C and D. Additional flexibility is provided by switch (S_1 A and B) which permits coupling coils (L_1 A and B) to be placed in either a series or parallel connection. The tuner is capable of operation at the maximum power level on all amateur bands between 80 and 10 meters, and it may be used with open-wire or "ribbon" feeders and directly driven antennas, such as V-beams or other center-fed, long-wire arrays.

Tuner Construction To conserve space, yet allow maximum circuit Q to be achieved, the tuner is constructed in a wooden box measuring 13"

wide, 10" high, and 12" deep. A piece of masonite is used for the panel. The two variable capacitors are mounted to the panel, as are the selector switch and the airwound inductor. The inductor is spaced away from the panel by two 2" long ceramic insulators. The four-winding inductor is made from a single section of coil stock, as shown in the drawing. Adjustable taps are made at the chosen coil turns by means of small phosphor-bronze clips attached to flexible insulated leads. The various terminals are mounted on a small aluminum plate which is mounted in a cutout area in the rear of the wood cabinet.

Tuner Operation The tuner is connected to the transmitter with a short length of low-impedance coaxial line.

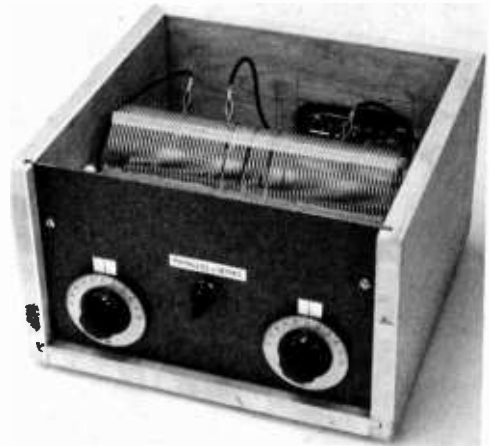

Figure 51

TUNER FOR CENTER-FED ANTENNA SYSTEMS

This balanced antenna tuner is designed to match center-fed antenna systems to transmitters employing the popular single-ended pi-network matching circuit. It may be connected to the transmitter with a random length of 52- or 75-ohm coaxial line. An SWR meter should be placed in the line for a tuning aid. The link-tuning capacitor is at the left, and the split-stator tank capacitor is at the right. Switch S, is between the two main tuning dials. The main inductor is made from a single section of coil stock, with the winding broken at appropriate points. Connections to the tuner are made at fittings mounted on the aluminum plate at the rear, right of the enclosure.

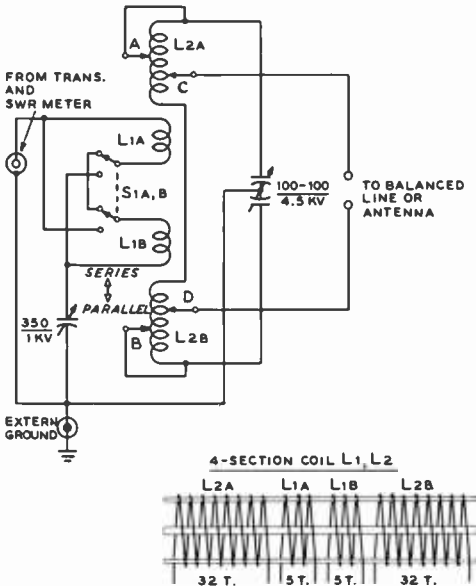

Figure 52

SCHEMATIC AND INDUCTOR FOR TUNER

Coil L₁A-B-L₂A-B is fabricated from a single length of coil stock (Illumintronix Air-Dux 2008, or equivalent). The coil is 2 1/2" inside diameter, 8 turns per inch of No. 14 wire. Starting from one end (after leaving a 6" lead) thirty-two turns are counted and the thirty-third turn is broken at the center to make leads for L₁A and L₁B. Five more turns are counted and the coil is broken in the same manner to make the opposite connection to coil L₁A, and to coil L₁B. In like manner, the taps to L₂A and L₂B are made. The adjacent leads from coils L₁A and L₁B are connected to the arms of the switch. Taps A and B short out the following approximate number of turns from the outer ends of the inductor: 80 meters, 4 turns; 40 meters, 16 turns; 20 meters, 28 turns; 15 meters, 29 turns; 10 meters, 30 turns. Phosphor-bronze clips are Mueller #88.

An SWR meter should be placed in the line. Adjustments are made to the tuner to properly load the transmitter while holding a reasonably low value of SWR on the coaxial line. If a center-fed tuned dipole (such as

shown in figure 2D) is used with the tuner, it may be operated on any high-frequency amateur band, provided the length of the flat top plus the feeder length is equal to or greater than one-half wavelength at the lowest operating frequency. For general "all-band" use, a 66-foot flat top with random-length open wire feedline is recommended. An antenna of this general type will be used as an example in discussing the adjustment of the tuner.

The transmitter is placed on the desired band and the coil taps are set as suggested in the illustration. Place both capacitors at full capacitance and place switch S₁ in the series position for 80- or 40-meter operation and in parallel position for 20-, 15-, or 10-meter operation. Adjust the capacitors and move clips A and B until resonance is established. (This may be determined with the aid of a grid-dip oscillator, if desired, before the transmitter is energized). Adjustment of the various clips and capacitors is done to provide proper loading of the transmitter with minimum SWR reading on the coaxial line. Adjustments should be symmetrical on each side of the coil and the taps should be set to employ the maximum value of inductance, since, quite probably, various tap settings and tuning adjustments may be found which will provide a degree of loading.

Adjustments should start with minimum circuit inductance for the band in use, progressively increasing inductance until the desired loading is achieved with maximum inductance in the circuit. Loading should finally be adjusted at the transmitter to provide proper settings for the output circuit of the transmitter. Once the adjustments of the tuner have been determined, the dial settings and tap points may be logged for future reference and the coil taps identified with a small spot of nail polish on the wire.

High-Frequency Directive Antennas

It is becoming of increasing importance in most types of radio communication to be capable of concentrating the radiated signal from the transmitter in a certain desired direction and to be able to discriminate at the receiver against reception from directions other than the desired one. Such capabilities involve the use of directive antenna arrays.

Few simple antennas, except the single vertical element, radiate energy equally well in all azimuth (horizontal or compass) directions. All horizontal antennas, except those specifically designed to give an omnidirectional azimuth radiation pattern such as the turnstile, have some directive properties. These properties depend on the length of the antenna in wavelengths, the height above ground, and the slope of the radiator.

The various forms of the half-wave horizontal antenna produce maximum radiation at right angles to the wire, but the directional effect is not great. Nearby objects also minimize the directivity of a dipole radiator, so that it hardly seems worth while to go to the trouble to rotate a simple half-wave dipole in an attempt to improve transmission and reception in any direction.

The half-wave doublet, folded-dipole, zepp, single-wire-fed, matched-impedance, and Q-section antennas all have practically the same radiation pattern *when properly built and adjusted*. They all are dipoles, and the feeder system, if it does not radiate in

itself, will have no effect on the radiation pattern.

22-1 Directive Antennas

When a multiplicity of radiating elements is located and phased so as to reinforce the radiation in certain desired directions and to neutralize radiation in other directions, a *directive antenna array* is formed.

The function of a directive antenna when used for transmitting is to give an increase in signal strength in some direction at the expense of radiation in other directions. For reception, one might find useful an antenna giving little or no gain in the direction from which it is desired to receive signals if the antenna is able to discriminate against interfering signals and static arriving from other directions. A good directive transmitting antenna, however, can also be used to good advantage for reception.

If radiation can be confined to a narrow beam, the signal intensity can be increased a great many times in the desired direction of transmission. This is equivalent to increasing the power output of the transmitter. On the higher frequencies, it is more economical to use a directive antenna than to increase transmitter power, if more than a few watts of power is being used.

Directive antennas for the high-frequency range have been designed and used commercially with gains as high as 23 db over a simple dipole radiator. Gains as high as 35

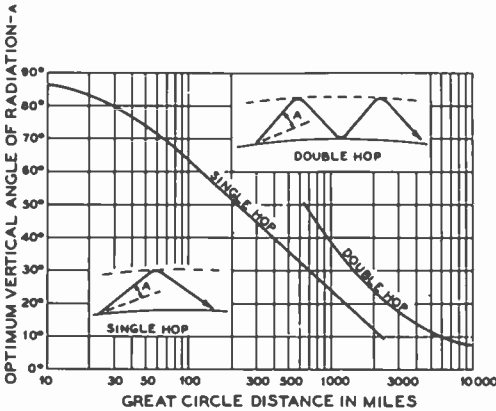

Figure 1
OPTIMUM ANGLE OF RADIATION
WITH RESPECT TO DISTANCES

Shown above is a plot of the optimum angle of radiation for one-hop and two hop communication. An operating frequency close to of radiation for one-hop and two-hop communication distance is assumed.

db are common in direct-ray microwave communication and radar systems. A gain of 23 db represents a power gain of 200 times and a gain of 35 db represents a power gain of almost 3500 times. However, an antenna with a gain of only 15 to 20 db is so sharp in its radiation pattern that it is usable to full advantage only for point-to-point work.

The increase in radiated power in the desired direction is obtained at the expense of radiation in the undesired directions. Power gains of 3 to 12 db seem to be most practical for amateur communication, since the width of a beam with this order of power gain is wide enough to sweep a fairly large area. Gains of 3 to 12 db represent effective transmitter power increases from 2 to 16 times.

Horizontal Pattern versus Vertical Angle There is a certain optimum vertical angle of radiation for sky-wave communication, this angle being dependent on distance, frequency, time of day, etc. Energy radiated at an angle much lower than this optimum angle is largely lost, while radiation at angles much higher than this optimum angle is often not nearly so effective.

For this reason, the horizontal directivity pattern as measured on the ground is of no

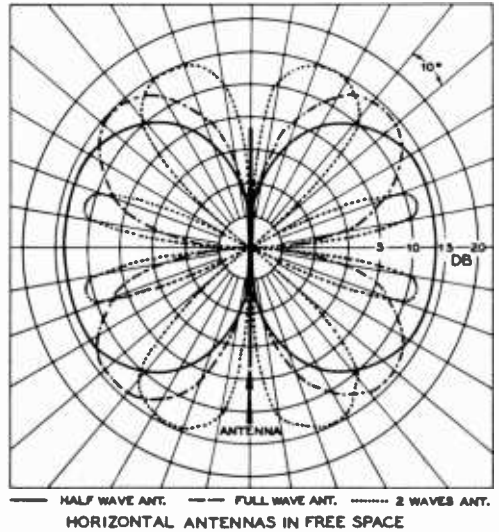

Figure 2

FREE-SPACE FIELD PATTERNS OF
LONG-WIRE ANTENNAS

The presence of the earth distorts the field pattern in such a manner that the azimuth pattern becomes a function of the elevation angle.

import when dealing with frequencies and distances dependent on sky-wave propagation. It is the horizontal directivity (or gain, or discrimination) measured at the most useful vertical angles of radiation that is of consequence. The horizontal radiation pattern, as measured on the ground, is considerably different from the pattern obtained at a vertical angle of 15 degrees, and still more different from a pattern obtained at a vertical angle of 30 degrees. In general, the energy which is radiated at angles higher than approximately 30 degrees above the earth, is effective only for local work at any frequency.

For operation at frequencies in the vicinity of 14 MHz, the most effective angle of radiation is usually about 15 degrees above the horizon, from any kind of antenna. The most effective angles for 10-meter operation are those in the vicinity of 10 degrees. Figure 1 is a chart giving the optimum vertical angle of radiation for sky-wave propagation in terms of the great-circle distance between the transmitting and receiving antennas.

Figure 3
DIRECTIVE GAIN OF
LONG-WIRE ANTENNAS

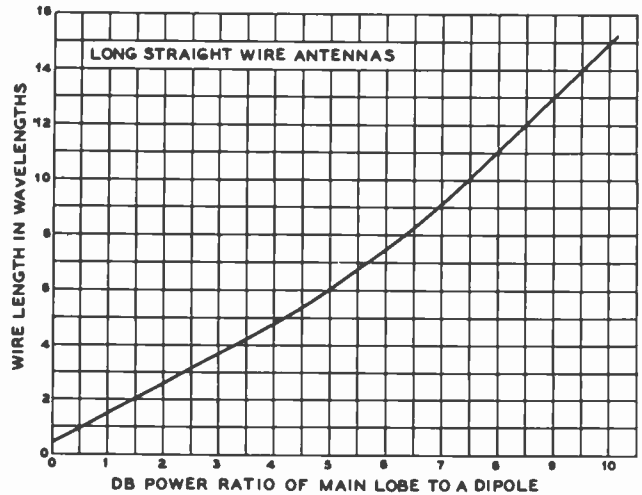

Types of Directive Arrays There is an enormous variety of directive antenna arrays that can give a substantial power gain in the desired direction of transmission or reception. However, some are more effective than others which require the same space. In general it may be stated that long-wire antennas of various types, such as the single long wire, the V beam, and the rhombic, are less effective for a given space than arrays composed of resonant elements, but the long-wire arrays have the significant advantage that they may be used over a relatively large frequency range while resonant arrays are usable only over a quite narrow frequency band.

22-2 Long-Wire Radiators

Harmonically operated long wires radiate better in certain directions than others, but cannot be considered as having appreciable directivity unless several wavelengths long. The current in adjoining half-wave elements flows in opposite directions at any instant, and, thus, the radiation from the various elements adds in certain directions and cancels in others.

A half-wave doublet in free space has a "doughnut" of radiation surrounding it. A full wave has 2 lobes, 3 half waves 3, etc. When the radiator is made more than 4 half wavelengths long, the *end* lobes (cones of radiation) begin to show noticeable power gain over a half-wave doublet, while the

broadside lobes get smaller and smaller in amplitude, even though numerous (figure 2).

The horizontal radiation pattern of such antennas depends on the vertical angle of radiation being considered. If the wire is more than 4 wavelengths long, the maximum radiation at vertical angles of 15° to 20° (useful for DX) is in line with the wire, being slightly greater a few degrees either side of the wire than directly off the ends. The directivity of the main lobes of radiation is not particularly sharp, and the minor lobes fill in between the main lobes to permit working stations in nearly all directions, though the power radiated broadside to the radiator will not be great if the radiator is more than a few wavelengths long. The directive gain of long-wire antennas, in terms of the wire length in wavelengths is given in figure 3.

To maintain the out-of-phase condition in adjoining half-wave elements throughout the length of the radiator, it is necessary that a harmonic antenna be fed either at *one end* or at a *current* loop. If fed at a voltage loop, the adjacent sections will be fed *in phase*, and a different radiation pattern will result.

The directivity of a long wire does not increase very much as the length is increased beyond about 15 wavelengths. This is due to the fact that all long-wire antennas are adversely affected by the r-f resistance of the wire, and because the current

LONG-ANTENNA DESIGN TABLE								
Approximate Length in Feet—End-Fed Antennas								
Frequency In MHz	1λ	1½λ	2λ	2½λ	3λ	3½λ	4λ	4½λ
29	33	50	67	84	101	118	135	152
28	34	52	69	87	104	122	140	157
21.4	45	68	91 ½	114 ½	136 ½	160 ½	185 ½	209 ½
21.2	45 ¼	68 ¼	91 ¾	114 ¾	136 ¾	160 ¾	185 ¾	209 ¾
21.0	45 ½	68 ½	92	115	137	161	186	210
14.2	67 ½	102	137	171	206	240	275	310
14.0	68 ½	103 ½	139	174	209	244	279	314
7.3	136	206	276	346	416	486	555	625
7.15	136 ½	207	277	347	417	487	557	627
7.0	137	207 ½	277 ½	348	418	488	558	628
4.0	240	362	485	618	730	853	977	1100
3.8	252	381	511	640	770	900	1030	1160
3.6	266	403	540	676	812	950	1090	1220
3.5	274	414	555	696	835	977	1120	
2.0	480	725	972	1230	1475			
1.9	504	763	1020	1280				
1.8	532	805	1080					

amplitude begins to become unequal at different current loops as a result of attenuation along the wire caused by radiation and losses. As the length is increased, the tuning of the antenna becomes quite broad. In fact, a long wire about 15 waves long is practically *aperiodic*, and works almost equally well over a wide range of frequencies.

One of the most practical methods of feeding a long-wire antenna is to bring one end of it into the radio room for direct connection to a tuned antenna circuit which is link-coupled through a harmonic-attenuating filter to the transmitter. The antenna can be tuned effectively to resonance for operating on any harmonic by means of the tuned circuit which is connected to the end

of the antenna. A ground is sometimes connected to the center of the tuned coil.

If desired, the antenna can be opened and current-fed at a point of *maximum current* by means of low-impedance ribbon line, or by a quarter-wave matching section and open line.

22-3 The V Antenna

If two long-wire antennas are built in the form of a V, it is possible to make two of the maximum lobes of one leg shoot in the same direction as two of the maximum lobes of the other leg of the V. The resulting antenna is bidirectional (two opposite directions) for the main lobes of radiation. Each side of the V can be made any odd or

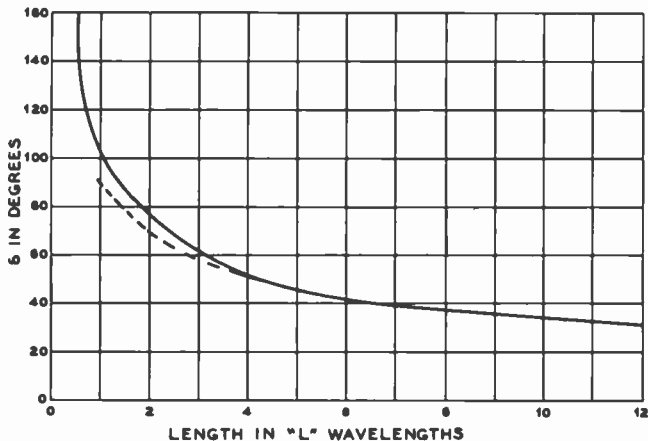

Figure 4
INCLUDED ANGLE FOR A V BEAM

Showing the included angle between the legs of a V beam for various leg lengths. For optimum alignment of the radiation lobe at the correct vertical angle with leg lengths less than three wavelengths, the optimum included angle is shown by the dashed curve.

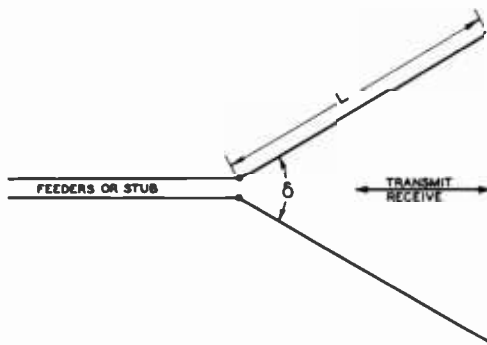

Figure 5
TYPICAL V BEAM ANTENNA

even number of quarter wavelengths, depending on the method of feeding the apex of the V. The complete system must be a multiple of half waves. If each leg is an even number of quarter waves long, the antenna must be voltage-fed at the apex; if an odd number of quarter waves long, current feed must be used.

By choosing the proper apex angle (figure 4 and figure 5) the lobes of radiation from the two long-wire antennas aid each other to form a bidirectional beam. Each wire by itself would have a radiation pattern similar to that for a long wire. The reaction of one on the other removes two of the four main lobes, and increases the other two in such a way as to form two lobes of still greater magnitude.

The correct wire lengths and the degree of the angle δ are listed in the *V-Antenna Design Table* for various frequencies in the 10-, 15-, 20- and 40-meter amateur bands. Apex angles for all side lengths are given in figure 4. The gain of a V beam in terms of the

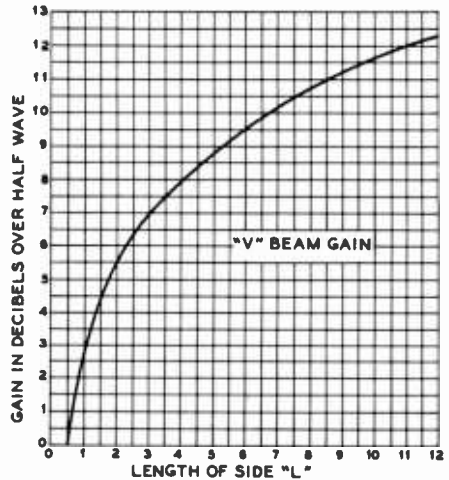

Figure 6
DIRECTIVE GAIN OF A V BEAM

This curve shows the approximate directive gain of a V beam with respect to a half-wave antenna located the same distance above ground, in terms of the side length L.

side length when optimum apex angle is used is given in figure 6.

The legs of a very long V antenna are usually so arranged that the included angle is twice the angle of the major lobe from a single wire if used alone. This arrangement concentrates the radiation of each wire along the bisector of the angle, and permits part of the other lobes to cancel each other.

With legs shorter than 3 wavelengths, the best directivity and gain are obtained with a somewhat smaller angle than that determined by the lobes. Optimum directivity for a one-wave V is obtained when the angle is 90° rather than 180° , as determined by the ground pattern alone.

V-ANTENNA DESIGN TABLE				
Frequency in kHz	$L = \lambda$ $\delta = 90^\circ$	$L = 2\lambda$ $\delta = 70^\circ$	$L = 4\lambda$ $\delta = 52^\circ$	$L = 8\lambda$ $\delta = 39^\circ$
28000	34'8"	69'8"	140'	280'
29000	33'6"	67'3"	135'	271'
21100	45'9"	91'9"	183'	366'
21300	45'4"	91'4"	182'6"	365'
14050	69'	139'	279'	558'
14150	68'6"	138'	277'	555'
14250	68'2"	137'	275'	552'
7020	138'2"	278'	558'	1120'
7100	136'8"	275'	552'	1106'
7200	134'10"	271'	545'	1090'

If very long wires are used in the V, the angle between the wires is almost unchanged when the length of the wires in wavelengths is altered. However, an error of a few degrees causes a much larger loss in directivity and gain in the case of the longer V than in the shorter one.

The vertical angle at which the wave is best transmitted or received from a horizontal V antenna depends largely on the included angle. The sides of the V antenna should be at least a half wavelength above ground; commercial practice dictates a height of approximately a full wavelength above ground.

22-4 The Rhombic Antenna

The terminated *rhombic* or *diamond* is probably the most effective directional antenna that is practical for amateur communication. This antenna is nonresonant, with the result that it can be used on four amateur bands, such as 10, 15, 20, and 40 meters. When the antenna is nonresonant, i.e., properly terminated, the system is unidirectional, and the wire dimensions are not critical.

Rhombic Termination When the free end is terminated with a resistance of a value between 700 and 800 ohms the rear lobes are eliminated, the forward gain is increased, and the antenna can be used on several bands without changes. The terminating resistance should be capable of dissipating one-third the power output of the transmitter, and should have very little reactance. For medium- or low-power transmitters, the noninductive *plaque* resistors will serve as a satisfactory termination. Several manufacturers offer special resistors suitable for terminating a rhombic antenna. The terminating device should, for technical reasons, present a small amount of inductive reactance at the point of termination.

A compromise terminating device commonly used consists of a terminated 250-foot or longer length of line made of resistance wire which *does not have too much resistance per unit length*. If the latter qualification is not met, the reactance of the line will be excessive. A 250-foot line

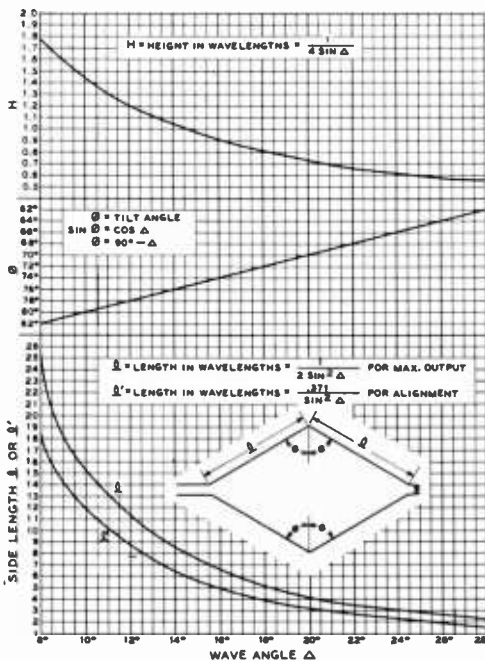

Figure 7

RHOMBIC ANTENNA DESIGN TABLE

Design data is given in terms of the wave angle (vertical angle of transmission and reception) of the antenna. The lengths *l* are for the "maximum output" design; the shorter lengths (*l'*) are for the "alignment" method which gives approximately 1.5 db less gain with a considerable reduction in the space required for the antenna. The values of side length, tilt angle, and height for a given wave angle are obtained by drawing a vertical line upward from the desired wave angle.

consisting of No. 25 *nicrome* wire, spaced 6 inches and terminated with 800 ohms, will serve satisfactorily. Because of the attenuation of the line, the lumped resistance at the end of the line need dissipate but a few watts even when high power is used. A half dozen 5000-ohm 2-watt carbon resistors in parallel will serve for all except very high power. The attenuating line may be folded back on itself to take up less room.

The determination of the best value of terminating resistor may be made while receiving, if the input impedance of the receiver is approximately 800 ohms. The value of resistor which gives the best di-

Figure 8
TYPICAL RHOMBIC ANTENNA DESIGN

The antenna system illustrated above may be used over the frequency range from 7 to 29 MHz without change. The directivity of the system may be reversed by the system discussed in the text.

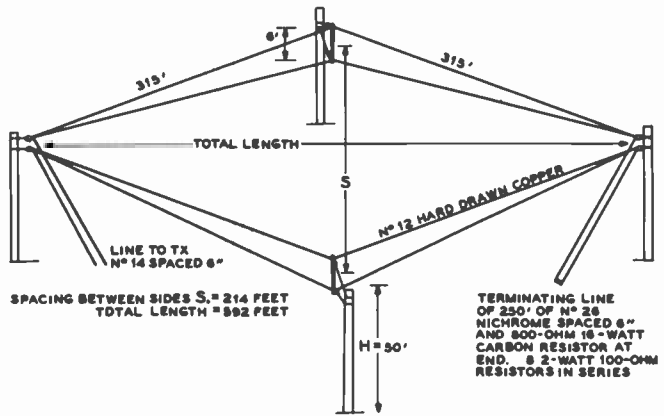

rectivity on reception will not give the most gain when transmitting, but there will be little difference between the two.

The input resistance of the rhombic which is reflected into the transmission line that feeds it is always somewhat less than the terminating resistance, and is around 700 to 750 ohms when the terminating resistor is 800 ohms.

The antenna should be fed with a non-resonant line having a characteristic impedance of 650 to 700 ohms. The four corners of the rhombic should be at least one-half wavelength above ground for the lowest frequency of operation. For three-band operation the proper tilt angle (ϕ) for the center band should be observed.

The rhombic antenna transmits a horizontally polarized wave at a relatively low angle above the horizon. The angle of radiation (wave angle) decreases as the height

above ground is increased in the same manner as with a dipole antenna. The rhombic should not be tilted in any plane. In other words, the poles should all be of the same height and the plane of the antenna should be parallel to the ground.

A considerable amount of directivity is lost when the terminating resistor is left off the end and the system is operated as a resonant antenna. If it is desired to reverse the direction of the antenna it is much better practice to run transmission lines to both ends of the antenna and then run the terminating line to the operating position. Then with the aid of two dpdt switches it will be possible to connect either feeder to the antenna changeover switch and the other feeder to the terminating line, thus reversing the direction of the array and maintaining the same termination for either direction of operation.

Figure 9
RHOMBIC ANTENNA GAIN

Showing the theoretical gain of a rhombic antenna, in terms of the side length, over a half-wave antenna mounted at the same height above the same type of soil.

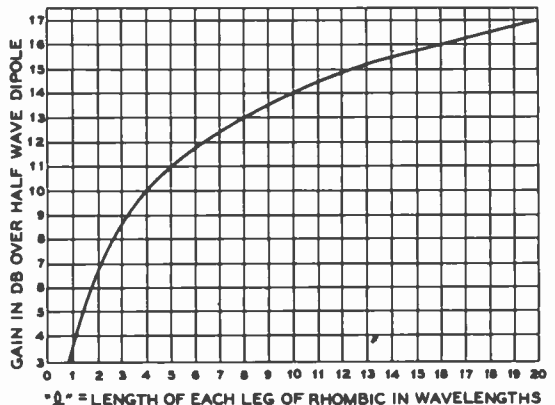

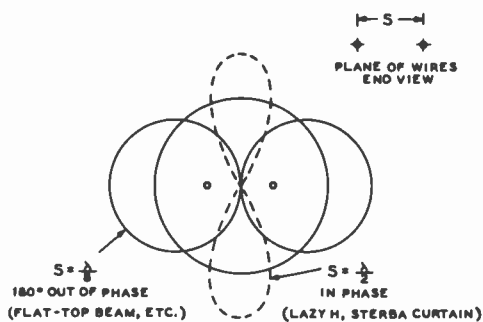

Figure 10

RADIATION PATTERNS OF A PAIR OF DIPOLES OPERATING WITH IN-PHASE EXCITATION, AND WITH EXCITATION 180° OUT OF PHASE

If the dipoles are oriented horizontally most of the directivity will be in the vertical plane; if they are oriented vertically most of the directivity will be in the horizontal plane.

Figure 7 gives curves for optimum-design rhombic antennas for both the maximum-output method and the alignment method. The alignment method is about 1.5 db down from the maximum output method but requires only about 0.74 as much leg length. The height and tilt angle are the same in either case. Figure 8 gives construction data for a recommended rhombic antenna for the 7.0- through 29.7-MHz bands. This antenna will give about 11 db gain in the 14.0-MHz band. The approximate gain of a rhombic antenna over a dipole (both above normal soil) is given in figure 9.

22-5 Stacked-Dipole Arrays

The characteristics of a half-wave dipole already have been described. When another dipole is placed in the vicinity and excited either directly or parasitically, the resultant radiation pattern will depend on the spacing and phase differential, as well as the relative magnitude of the currents. With spacings less than 0.65 wavelength, the radiation is mainly broadside to the two wires (bidirectional) when there is no phase difference, and *through* the wires (end fire) when the wires are 180° out of phase. With phase difference between 0° and 180° (45°,

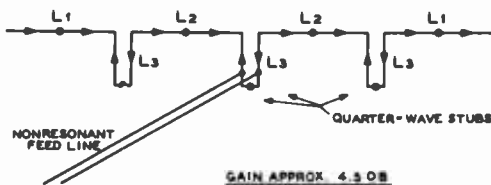

Figure 11

THE FRANKLIN OR COLLINEAR ANTENNA ARRAY

An antenna of this type, regardless of the number of elements, attains all of its directivity through sharpening of the horizontal or azimuth radiation pattern; no vertical directivity is provided. Hence a long antenna of this type has an extremely sharp azimuth pattern, but no vertical directivity.

90°, and 135° for instance), the pattern is unsymmetrical, the radiation being *greater* in one direction than in the opposite direction.

With spacings of more than 0.8 wavelength, more than two main lobes appear for all phasing combinations; hence, such spacings are seldom used.

In-Phase Spacing With the dipoles driven so as to be in phase, the most effective spacing is between 0.5 and 0.7 wavelength. The latter provides greater gain, but minor lobes are present which do not appear at 0.5-wavelength spacing. The radiation is broadside to the plane of the wires, and the gain is slightly greater than can be obtained from two dipoles out of phase. The gain falls off rapidly for spacings less than 0.375 wavelength, and there is little point in using spacing of 0.25 wavelength or less with in-phase dipoles, except where it is desirable to increase the radiation resistance. (See *Multiwire Doublet*.)

Out of Phase Spacing When the dipoles are fed 180° *out of phase*, the directivity is through the plane of the wires, and is greatest with *close spacing*, though there is but little difference in the pattern after the spacing is made less than 0.125 wavelength. The radiation resistance becomes so low for spacings of less than 0.1 wavelength that such spacings are not practical.

In the three foregoing examples, most of the directivity provided is in a plane at a right angle to the wires, though when out

COLLINEAR ANTENNA DESIGN CHART			
Frequency in MHz	L ₁	L ₂	L ₃
28.5	16'8"	17'	8'6"
21.2	22'8"	23'3"	11'6"
14.2	33'8"	34'7"	17'3"
7.15	67'	68'8"	34'4"
4.0	120'	123'	61'6"
3.6	133'	136'5"	68'2"

of phase, the directivity is in a line *through* the wires, and when in phase, the directivity is *broadside* to them. Thus, if the wires are oriented vertically, mostly horizontal directivity will be provided. If the wires are oriented horizontally, most of the directivity obtained will be *vertical* directivity.

To increase the sharpness of the directivity in all planes that include one of the wires, additional identical elements are added *in the line of the wires*, and fed so as to be *in phase*. The familiar lazy-H array is one array utilizing both types of directivity in the manner prescribed. The two-section 8JK flat-top beam is another.

These two antennas in their various forms are directional in a horizontal plane, in addition to being low-angle radiators, and are perhaps the most practical of the *bidirectional* stacked-dipole arrays for amateur use. More phased elements can be used to provide greater directivity in planes including one of the radiating elements. The H then becomes a *Sterba-curtain* array.

For unidirectional work the most practical stacked-dipole arrays for amateur-band use are parasitically excited systems using relatively close spacing between the reflectors and the directors. Antennas of this type are described in detail in a later chapter. The next most practical unidirectional array is an H or a Sterba curtain with a similar system placed approximately one-quarter wave behind. The use of a reflector system in conjunction with any type of stacked-dipole broadside array will increase the gain by 3 db.

Collinear Arrays The simple *collinear antenna* array is a very effective radiating system for the 3.5- and 7.0-MHz bands, but its use is not recommended on higher frequencies since such arrays do not possess any vertical directivity. The elevation radiation pattern for such an array is essentially the same as for a half-wave

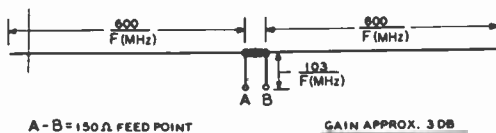

Figure 12
DOUBLE EXTENDED ZEPP ANTENNA
 For best results, antenna should be tuned to operating frequency by means of grid-dip oscillator.

dipole. This consideration applies whether the elements are of normal length or are extended.

The collinear antenna consists of two or more radiating sections from 0.5 to 0.65 wavelengths long, with the current in phase in each section. The necessary phase reversal between sections is obtained through the use of resonant tuning stubs as illustrated in figure 11. The gain of a collinear array using half-wave elements (in decibels) is approximately equal to the number of elements in the array. The exact figures are as follows:

Number of Elements	2	3	4	5	6
Gain in Decibels	1.8	3.3	4.5	5.3	6.2

As additional in-phase collinear elements are added to a doublet, the radiation resistance goes up much faster than when additional half waves are added out of phase (harmonic operated antenna).

For a collinear array of from 2 to 6 elements, the terminal radiation resistance in ohms at any current loop is approximately 100 times the number of elements.

It should be borne in mind that the *gain* from a collinear antenna depends on the

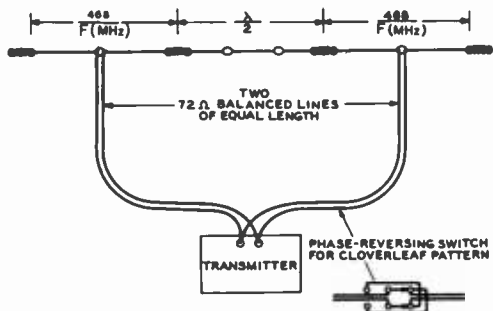

Figure 13
TWO COLLINEAR HALF-WAVE ANTENNAS IN PHASE PRODUCE A 3 DB GAIN WHEN SEPARATED ONE-HALF WAVELENGTH

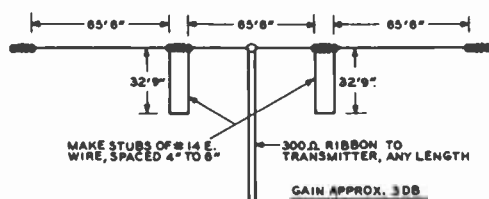

Figure 14

PRECUT LINEAR ARRAY FOR 40-METER OPERATION

sharpness of the horizontal directivity since no vertical directivity is provided. An array with several collinear elements will give considerable gain, but will have a sharp horizontal radiation pattern.

Double Extended Zepp The gain of a conventional two-element Franklin collinear antenna can be increased to a value approaching that obtained from a three-element Franklin, simply by making the two radiating elements 230° long instead of 180° long. The phasing stub is shortened correspondingly to maintain the whole array in resonance. Thus, instead of having 0.5-wavelength elements and 0.25-wavelength stub, the elements are made 0.64 wavelength long and the stub is approximately 0.11 wavelength long.

Dimensions for the double extended zepp are given in figure 12.

The vertical directivity of a collinear antenna having 230° elements is the same as for one having 180° elements. There is little advantage in using extended sections when the total length of the array is to be greater than about 1.5 wavelength over all since the gain of a collinear antenna is proportional to the overall length, whether the individual radiating elements are $\frac{1}{4}$ -wave, $\frac{1}{2}$ -wave or $\frac{3}{4}$ -wave in length.

Spaced Half Wave Antennas The gain of two collinear half waves may be increased

by increasing the physical spacing between the elements, up to a maximum of about one-half wavelength. If the half-wave elements are fed with equal lengths of transmission line, correctly phased, a gain of about 3.3 db is produced. Such an antenna is shown in figure 13. By means of

a phase reversing switch, the two elements may be operated out of phase, producing a cloverleaf pattern with slightly less maximum gain.

A three-element precut array for 40-meter operation is shown in figure 14. It is fed directly with 300-ohm ribbon line, and may be matched to a 52-ohm coaxial output transmitter by means of a balun.

22-6 Broadside Arrays

Collinear elements may be stacked above or below another string of collinear elements to produce what is commonly called a *broadside* array. Such an array, when horizontal elements are used, possesses vertical directivity in proportion to the number of broadsided (vertically stacked) sections which have been used.

Since broadside arrays do have good vertical directivity their use is recommended on the 14-MHz band and on those higher in frequency. One of the most popular of simple broadside arrays is the *Lazy H* array of figure 15. Horizontal collinear elements stacked two above two make up this antenna system which is highly recommended when moderate gain without too much directivity is desired. It has high radiation resistance and a gain of approximately 5.5 db. The high radiation resistance results in low voltages and a broad resonance curve, which permits use of inexpensive insulators and enables the array to be used over a fairly wide range in frequency. For dimensions, see the stacked dipole design table.

Stacked Dipoles Vertical stacking may be applied to strings of collinear elements

longer than two half waves. In such arrays, the end quarter wave of each string of radiators usually is bent in to meet a similar bent quarter wave from the opposite-end radiator. This provides better balance and better coupling between the upper and lower elements when the array is current-fed. Arrays of this type are shown in figure 16, and are commonly known as *curtain arrays*.

Correct length for the elements and stubs can be determined for any stacked-dipole array from the *Stacked-Dipole Design Table*.

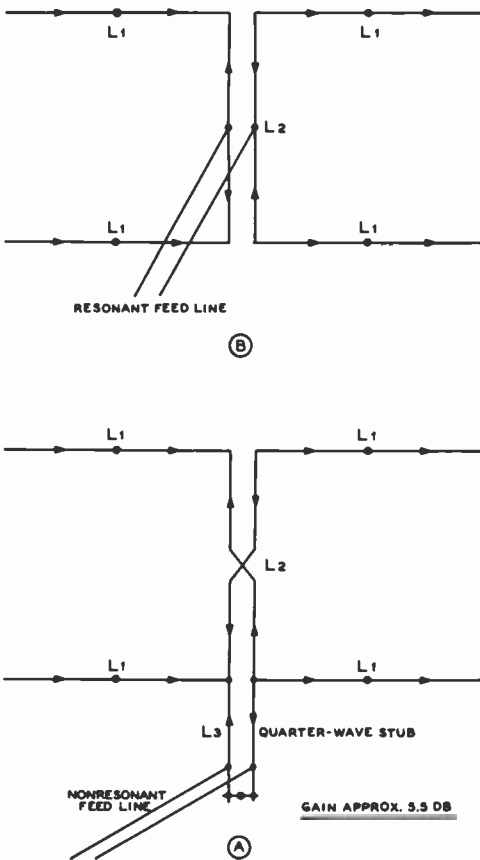

Figure 15

THE LAZY H ANTENNA SYSTEM

Stacking the collinear pairs gives both horizontal and vertical directivity. As shown, the array will give about 5.5 db gain. Note that the array may be fed either at the center of the phasing section or at the bottom; if fed at the bottom the phasing section must be twisted through 180° .

In the arrays of figure 16 the arrowheads represent the direction of current flow at any given instant. The dots on the radiators represent points of maximum current. All arrows should point in the same direction in each portion of the radiating sections of an antenna in order to provide a field in phase for broadside radiation. This condition is satisfied for the arrays illustrated in figure 16. Figures 16A and 16C show simple methods of feeding a short Sterba curtain, while

an alternative method of feed is shown in the higher-gain antenna of figure 16B.

In the case of each of the arrays of figure 16, and also the Lazy H of figure 15, the array may be unidirectional and the gain increased by 3 db if an exactly similar array is constructed and placed approximately $\frac{1}{4}$ wave behind the driven array. A screen or mesh of wires, slightly greater in area than the antenna array, may be used instead of an additional array as a reflector to obtain a unidirectional system. The spacing between the reflecting wires may vary from 0.05 to 0.1 wavelength with the spacing between the reflecting wires the smallest directly behind the driven elements. The wires in the untuned reflecting system should be parallel to the radiating elements of the array, and the spacing of the complete reflector system should be approximately 0.2 to 0.25 wavelength behind the driven elements.

On frequencies below perhaps 100 MHz, it normally will be impractical to use a wire-screen reflector behind an antenna array such as a Sterba curtain or a Lazy H. Parasitic elements may be used as reflectors or directors, but parasitic elements have the disadvantage that their operation is selective with respect to relatively small changes in frequency. Nevertheless, parasitic reflectors for such arrays are quite widely used.

The X-Array In section 22-5 it was shown

how two dipoles may be arranged in phase to provide a power gain of about 3 db. If two such pairs of dipoles are stacked in a vertical plane and properly phased, a simplified form of in-phase curtain is formed, providing an over-all gain of about 6 db. Such an array is shown in figure 17. In this X-array, the four dipoles are all in phase, and are fed by four sections of 300-ohm line, each one-half wavelength long, the free ends of all four lines being connected in parallel. The feed impedance at the junction of these four lines is about 75 ohms, and a length of 75-ohm twin lead may be used for the feedline to the array.

An array of this type is quite small for the 28-MHz band, and is not out of the question for the 21-MHz band. For best results, the bottom section of the array should be one-half wavelength above ground.

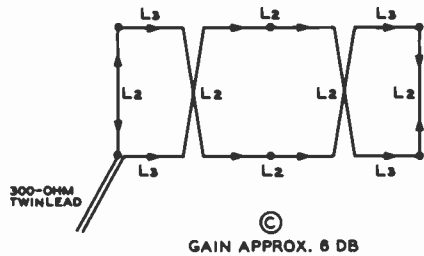
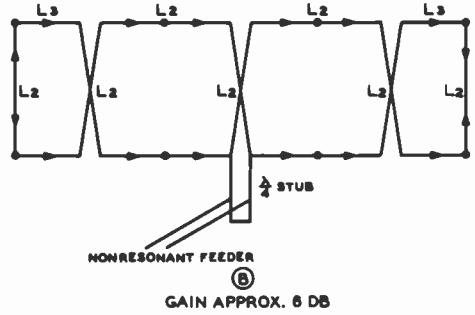
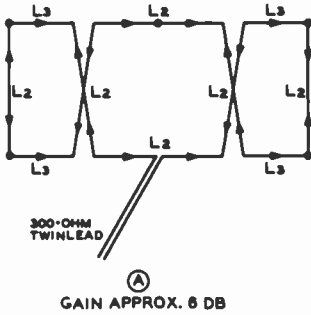

Figure 16

THE STERBA-CURTAIN ARRAY

Approximate directive gains along with alternative feed methods are shown.

LAZY H AND STERBA (STACKED-DIPOLE) DESIGN TABLE

Frequency in MHz	L ₁	L ₂	L ₃
7.0	68'2"	70'	35'
7.3	65'10"	67'6"	33'9"
14.0	34'11"	35'	17'6"
14.2	33'8"	34'7"	17'3"
14.4	33'4"	34'2"	17'
21.0	22'9"	23'3"	11'8"
21.5	22'3"	22'9"	11'5"
27.3	17'7"	17'10"	8'11"
28.0	17'	17'7"	8'9"
29.0	16'6"	17'	8'6"
50.0	9'7"	9'10"	4'11"
52.0	9'3"	9'5"	4'8"
54.0	8'10"	9'1"	4'6"
144.0	39.8"	40.5"	20.3"
146.0	39"	40"	20"
148.0	38.4"	39.5"	19.8"

The Double-Bruce Array The Bruce Beam consists of a long wire folded so that vertical elements carry in-phase currents while the horizontal elements carry out-of-phase currents. Radiation from the horizontal sections is low since only a small current flows in this part of the wire, and it is largely phased-out. Since the height of the Bruce Beam is only one-quarter wavelength, the gain per linear foot of array is quite low. Two Bruce Beams may be combined as shown in figure 18 to produce the Double Bruce array. A four

section Double Bruce will give a vertically polarized emission, with a power gain of 5 db over a simple dipole, and is a very simple beam to construct. This antenna, like other so-called broadside arrays, radiates

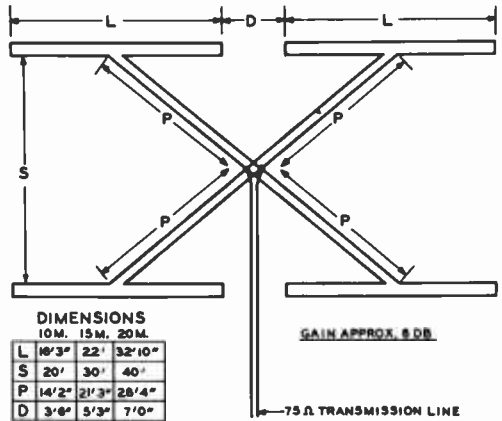

Figure 17

THE X-ARRAY FOR 28, 21, OR 14 MHz

The entire array (with the exception of the 75-ohm feedline) is constructed of 300-ohm ribbon line. Be sure phasing lines (P) are polarized correctly, as shown.

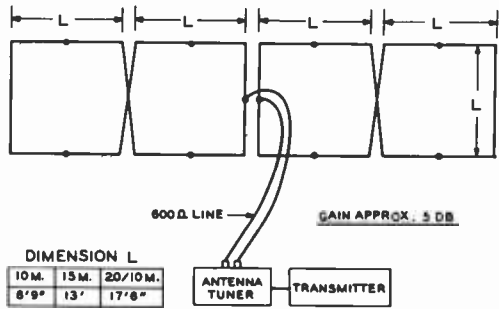

Figure 18

THE DOUBLE-BRUCE ARRAY FOR 10, 15, AND 20 METERS

If a 600-ohm feed line is used, the 20-meter array will also perform on 10 meters as a Sterba curtain, with an approximate gain of 9 db.

maximum power at right angles to the plane of the array.

The feed impedance of the Double Bruce is about 750 ohms. The array may be fed with a quarter-wave stub made of 300-ohm ribbon line and a feedline made of 150-ohm ribbon line. Alternatively, the array may be fed directly with a wide-spaced 600-ohm transmission line (figure 18). The feedline should be brought away from the Double Bruce for a short distance before it drops downward, to prevent interaction between the feedline and the lower part of the center phasing section of the array. For best results, the bottom sections of the array should be one-half wavelength above ground.

Arrays such as the X-array and the Double Bruce are essentially high-impedance devices, and exhibit relatively broadband characteristics. They are less critical of adjustment than a parasitic array, and they work well over a wide frequency range such as is encountered on the 28- to 29.7-MHz band.

The Bi-Square Broadside Array Illustrated in figure 19 is a simple method of feeding a small broadside array. As two arrays of this type can be supported at right angles from a single pole without interaction, it offers a solution to the problem of suspending two arrays in a restricted space with a minimum of erection work. The free space directivity gain is slightly

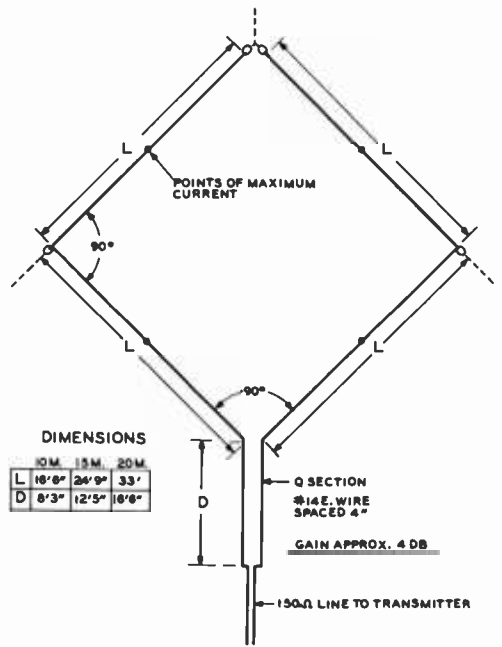

Figure 19

THE BI-SQUARE BROADSIDE ARRAY

This bidirectional array is related to the Lazy H, and in spite of the oblique elements, is horizontally polarized. It has slightly less gain and directivity than the Lazy H, the free-space directivity gain being approximately 4 db. Its chief advantage is the fact that only a single pole is required for support, and two such arrays may be supported from a single pole without interaction if the planes of the elements are at right angles. A 600-ohm line may be substituted for the twin lead, and either operated as a resonant line, or made nonresonant by the incorporation of a matching stub.

less than that of a Lazy H, but is still worthwhile, being approximately 4 db over a half-wave horizontal dipole at the same average elevation.

When two *Bi-Square* arrays are suspended at right angles to each other (for general coverage) from a single pole, the Q-sections should be well separated or else symmetrically arranged in the form of a square (the diagonal conductors forming one Q-section) in order to minimize coupling between them. The same applies to the line if open construction is used instead of twin lead, but

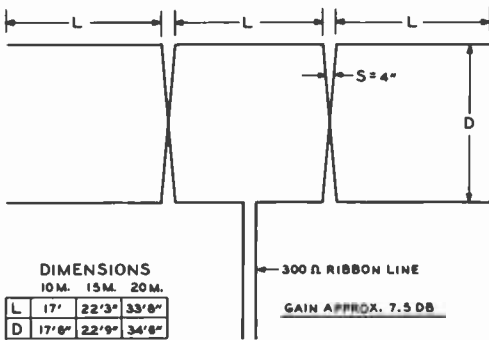

Figure 20

THE SIX-SHOOTER BROADSIDE ARRAY

if twin lead is used the coupling can be made negligible simply by separating the two twin-lead lines by at least two inches and twisting one twin lead so as to effect a transposition every foot or so.

When tuned feeders are employed, the Bi-Square array can be used on half frequency as an end-fire vertically polarized array, giving a slight practical DX signal

gain over a vertical half-wave dipole at the same height.

A second Bi-Square serving as a reflector may be placed 0.15 wavelength behind this antenna to provide an over-all gain of 8.5 db. The reflector may be tuned by means of a quarter-wave stub which has a movable shorting bar at the bottom end.

The Six-Shooter Broadside Array

The array of figure 20 is recommended for the 10- to 30-MHz range as a good compromise between gain, directivity, compactness, mechanical simplicity, ease of adjustment, and bandwidth, when the additional array width and greater directivity are not obtainable. The free-space directivity gain is approximately 7.5 db over one element, and the practical DX signal gain over one element at the same average elevation is of about the same magnitude when the array is sufficiently elevated. To show up to best advantage the array should be elevated sufficiently to put the lower elements well in the clear, and preferably at least 0.5 wavelength above ground.

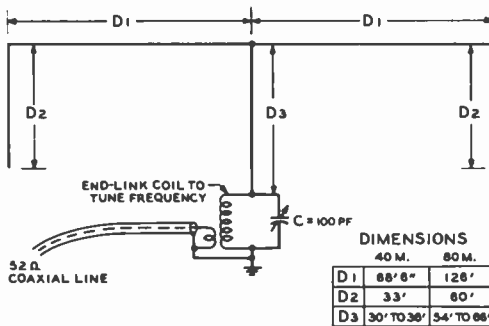

Figure 21

BOBTAIL BIDIRECTIONAL BROADSIDE CURTAIN FOR THE 7-MHz OR THE 4.0-MHz AMATEUR BANDS

This simple vertically polarized array provides low angle radiation and response with comparatively low pole heights, and is very effective for DX work on the 7-MHz band or the 4.0-MHz phone band. Because of the phase relationships, radiation from the horizontal portion of the antenna is effectively suppressed. Very little current flows in the ground lead to the coupling tank; so an elaborate ground system is not required, and the length of the ground lead is not critical so long as it uses heavy wire and is reasonably short.

The Bobtail Bidirectional Broadside Curtain

Another application of vertical orientation of the radiating elements of an array in order to obtain low-angle radiation at the lower end of the high-frequency range with low pole heights is illustrated in figure 21. When precut to the specified dimensions this single-pattern array will perform well over the 7-MHz amateur band or the 4-MHz amateur phone band. For the 4-MHz band, the required two poles need be only 70 feet high, and the array will provide a practical signal gain averaging from 7 to 10 db over a horizontal half-wave dipole utilizing the same pole height when the path length exceeds 2500 miles.

The horizontal directivity is only moderate, the beam width at the half-power points being slightly greater than that obtained from three cophased vertical radiators fed with equal currents. This is explained by the fact that the current in each of the two outer radiators of this array carries only about half as much current as the center-driven element. While this binomial current distribution suppresses the end-fire lobe that

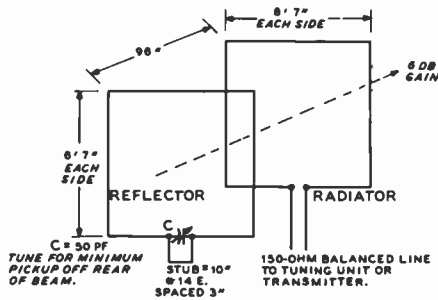

NOTE: SIDE LENGTH = 11' 6" FOR 21 MHz
 17' 7" FOR 14 MHz
 ELEMENT SPACING 96" FOR EACH BAND.
 STUB LENGTH APPROX. 15" FOR 21 MHz
 20" FOR 14 MHz

Figure 22

THE CUBICAL QUAD ANTENNA FOR THE 10-, 15-, OR 20-METER BANDS

occurs when an odd number of parallel radiators with half-wave spacing are fed equal currents, the array still exhibits some high-angle radiation and response off the end as a result of imperfect cancellation in the flat-top portion. This is not sufficient to affect the power gain appreciably, but does degrade the discrimination somewhat.

A moderate amount of sag can be tolerated at the center of the flat top, where it connects to the driven vertical element. The poles and antenna tank should be so located with respect to each other that the driven vertical element drops approximately straight down from the flat top.

Normally the antenna tank will be located in the same room as the transmitter, to facilitate adjustment when changing frequency. In this case it is recommended that the link-coupled tank be located across the room from the transmitter if much power is used, in order to minimize r-f feedback difficulties which might occur as a result of the asymmetrical high-impedance feed. If tuning of the antenna tank from the transmitter position is desired, flexible shafting can be run from the antenna tank capacitor to a control knob at the transmitter.

The lower end of the driven element is quite "hot" if much power is used, and the lead-in insulator should be chosen with this in mind. The ground connection need not have very low resistance, as the current

flowing in the ground connection is comparatively small. A stake or pipe driven a few feet in the ground will suffice. However, the ground lead should be of heavy wire and preferably the length should not exceed about 10 feet at 7 MHz or about 20 feet at 4 MHz in order to minimize reactive effects due to its inductance. If it is impossible to obtain this short a ground lead, a piece of screen or metal sheet about four feet square may be placed parallel to the earth in a convenient location and used as an artificial ground. A fairly high C/L ratio ordinarily will be required in the antenna tank in order to obtain adequate coupling and loading.

22-7 The Cubical Quad Beam

The *Cubical Quad* may be thought of as a smaller version of the Bi-Square antenna. The radiator loop consists of a wavelength of wire folded into a rectangular or diamond shape, one-quarter of a wavelength on a side, as shown in figure 22. The director is a similar element placed in an end-fire position, and additional directors or a reflector may be added to the driven loop. The Quad, when fed at the bottom radiates a horizontally polarized signal.

A two-element Quad may be composed of driven element and director, with the director loop placed about 0.12-wavelength distance in front of the driven element. Power gain is about 7 decibels over a dipole antenna. A reflector loop placed about 0.12 wavelength behind the two-element assembly forms a three-element Quad having a power gain of about 8.5 decibels. Quad antennas for the 20-, 15-, or 10-meter bands have been built with up to five elements, with correspondingly higher gain figures.

Element lengths for the Quad antenna may be expressed in the circumference of the loop, and the following formulas apply for high-frequency Quads made of wire and having a square or diamond configuration:

Circumference of driven element:

$$(\text{feet}) \frac{1005}{f_{\text{MHz}}}$$

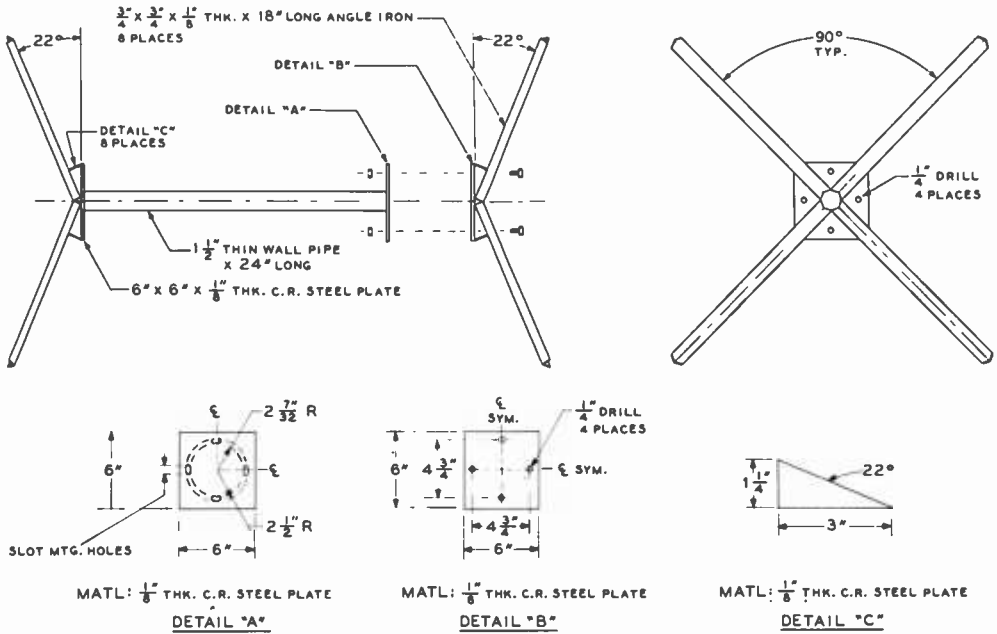

Figure 23

SPIDER CENTER STRUCTURE FOR QUAD ANTENNA

Circumference of director element:

$$\text{(feet)} \frac{975}{f_{\text{MHz}}}$$

Circumference of reflector element:

$$\text{(feet)} \frac{1030}{f_{\text{MHz}}}$$

A simple two-element Quad for 20, 15, or 10 meters is illustrated in figure 22. The elements are shortened a bit over those figures derived by formula and adjustable stubs are included in series with the loop wire to permit tuning to frequency. The Quad is fed with a 300-ohm balanced TV-type ribbon line and should employ an antenna tuner at the transmitter end of the line if a pi-network output stage is used in the transmitter. Alternatively, a 72-ohm coaxial line with a balun at the Quad terminals may be used for unbalanced feed. The radiation resistance of the Quad is about 100 ohms and a reasonably low value of SWR is obtainable across any one amateur band.

If a reflector stub is used, the array may be adjusted by aiming the back of the antenna at a nearby field-strength meter and adjusting the stub capacitor for minimum received signal at the operating frequency.

This simple antenna provides high gain for its size. The elements may be made of No. 14 wire with the array built on a light framework of bamboo arms with a wooden center structure. For maximum utility and longer life, the metal support structure of figure 23 is recommended. Built of conduit pipe and angle iron, this "spider" will accommodate bamboo or Fiberglass arms of sufficient length for a 20-, 15-, or 10-meter Quad, or an interlaced triband version. The "spider" is made in two parts so the elements may be assembled on the ground and carried to the top of the tower for final assembly. Boom length is only two feet, so the entire antenna can be easily supported by a single man.

Full information on interlaced Quads and complete Quad designs may be found in the handbook *All About Cubical Quad Antennas*, Radio Publications, Wilton, Conn.

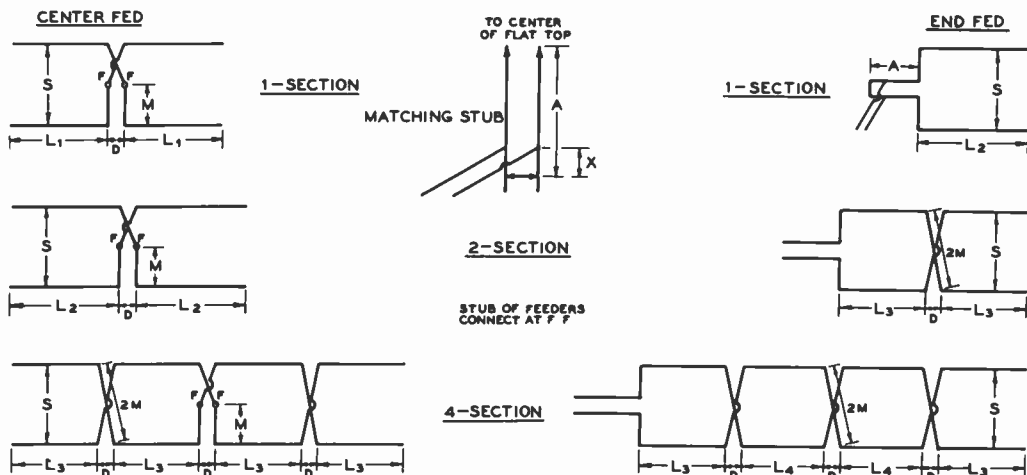

Figure 24

FLAT-TOP BEAM (8JK ARRAY) DESIGN DATA

Band	S	L ₁	L ₂	L ₃	L ₄	M	D	A (¼)	A (½)	A (¾)	X
40	17'	33'6"	59'	51'8"	43'1"	8'8"	4'	26'	59'	94'	4'
20	8'8"	17'	30'	26'4"	22'	4'9"	2'	13'	30'	48'	2'
15	7'10"	12'8"	22'6"	18'3"	15'	4'0"	1'8"	10'6"	22'	36'	1'6"
10	5'2"	8'6"	15'	12'7"	10'	2'8"	1'6"	7'	15'	24'	1'

Dimension chart for flat-top beam antennas. The meanings of the symbols are as follows: L₁, L₂, L₃, L₄, the lengths of the sides of the flat-top sections as shown. L₁ is length of the sides of single-section center-fed, L₂ single-section end-fed and 2-section center fed, L₃ 4-section center-fed and end-sections of 4-section end-fed, and L₄ middle sections of 4-section end-fed.

S, the spacing between the flat-top wires.

M, the wire length from the outside to the center of each cross-over.

D, the spacing lengthwise between sections.

A (¼), the approximate length for a quarter-wave stub.

A (½), the approximate length for a half-wave stub.

A (¾), the approximate length for a three-quarter wave stub.

X, the approximate distance above the shorting wire of the stub for the connection of a 600-ohm line. This distance, as given in the table, is approximately correct only for 2-section flat-tops.

For single-section types it will be smaller and for 4-section types it will be larger.

The lengths given for a half-wave stub are applicable only to single-section center-fed flat-tops. To be certain of sufficient stub length, it is advisable to make the stub a foot or so longer than shown in the table, especially with the end-fed types. The lengths, A, are measured from the point where the stub connects to the flat-top.

Both the center and end-fed types may be used horizontally. However, where a vertical antenna is desired, the flat-tops can be turned on end. In this case, the end-fed types may be more convenient, feeding from the lower end.

22-8 End-Fire Directivity

By spacing two half-wave dipoles, or collinear arrays, at a distance of from 0.1 to 0.25 wavelength and driving the two 180° out of phase, directivity is obtained through the two wires at right angles to

them. Hence, this type of bidirectional array is called *end-fire*. A better idea of end-fire directivity can be obtained by referring to figure 10.

Remember that *end-fire* refers to the radiation with respect to the two wires in the array rather than with respect to the array as a whole.

The vertical directivity of an end-fire bidirectional array which is oriented horizontally can be increased by placing a similar end-fire array a half wave below it, and excited in the same phase. Such an array is a combination broadside and end-fire affair.

8JK Flat-Top Beam A very effective bidirectional end-fire array is the *8JK Flat-Top Beam*. Essentially, this antenna consists of two close-spaced dipoles or collinear arrays. Because of the close spacing, it is possible to obtain the proper phase relationships in multisection flat tops by crossing the wires at the voltage loops, rather than by resorting to phasing stubs. This greatly simplifies the array. (See figure 24.) Any number of sections may be used, though the one- and two-section arrangements are the most popular. Little extra gain is obtained by using more than four sections, and trouble from phase shift may appear.

A center-fed single-section flat-top beam cut according to the table, can be used quite successfully on its second harmonic, the pattern being similar except that it is a little sharper. The single-section array can also be used on its fourth harmonic with some success, though there then will be four cloverleaf lobes, much the same as with a full-wave antenna.

If a flat-top beam is to be used on more than one band, tuned feeders are necessary.

The radiation resistance of a flat-top beam is rather low, especially when only one section is used. This means that the voltage will be high at the voltage loops. For this reason, especially good insulators should be used for best results in wet weather.

The exact lengths for the radiating elements are not especially critical, because slight deviations from the correct lengths can be compensated in the stub or tuned feeders. Proper stub adjustment is covered in Chapter Twenty-four. Suitable radiator lengths and approximate stub dimensions are given in the accompanying design table.

Figure 24 shows *top views* of six types of flat-top beam antennas. The dimensions for using these antennas on different bands are given in the design table.

The antennas are tuned to the frequency used, by adjusting the shorting wire on the

stub, or tuning the feeders, if no stub is used. The data in the table may be extended to other bands or frequencies by applying the proper factor. Thus, for 50- to 52-MHz operation, the values for 28 to 29 MHz are divided by 1.8.

All of the antennas have a bidirectional horizontal pattern on their fundamental frequency. The maximum signal is broadside to the flat top. The single-section type has this pattern on both its fundamental frequency and second harmonic. The other types have four main lobes of radiation on the second and higher harmonics. The nominal gains of the different types over a half-wave comparison antenna are as follows: single-section, 4 db; two-section, 6 db; four-section, 8 db.

Although the center-fed type of flat-top generally is to be preferred because of its symmetry, the end-fed type often is convenient or desirable. For example, when a flat-top beam is used vertically, feeding from the lower end is in most cases more convenient.

If a multisection flat-top array is end-fed instead of center-fed, and tuned feeders are used, stations off the ends of the array can be worked by tying the feeders together and working the whole affair, feeders and all, as a long-wire harmonic antenna. A single-pole double-throw switch can be used for changing the feeders and directivity.

The Triplex Beam The *Triplex beam* is a modified version of the flat-top antenna which uses folded dipoles for the half wave elements of the array. The use of folded dipoles results in higher radiation resistance of the array, and a high over-all system performance. Three wire dipoles are used for the elements, and 300-ohm twin-lead is used for the two phasing sections. A recommended assembly for Triplex beams for 28, 21, and 14 MHz is shown in figure 25. The gain of a Triplex beam is about 4.5 db over a dipole.

22-8 Combination End-Fire and Broadside Arrays

Any of the end-fire arrays previously described may be stacked one above the other or placed end to end (side by side) to give

Figure 24
THE TRIPLEX FLAT-TOP BEAM
ANTENNA FOR 10, 15, AND 20
METERS

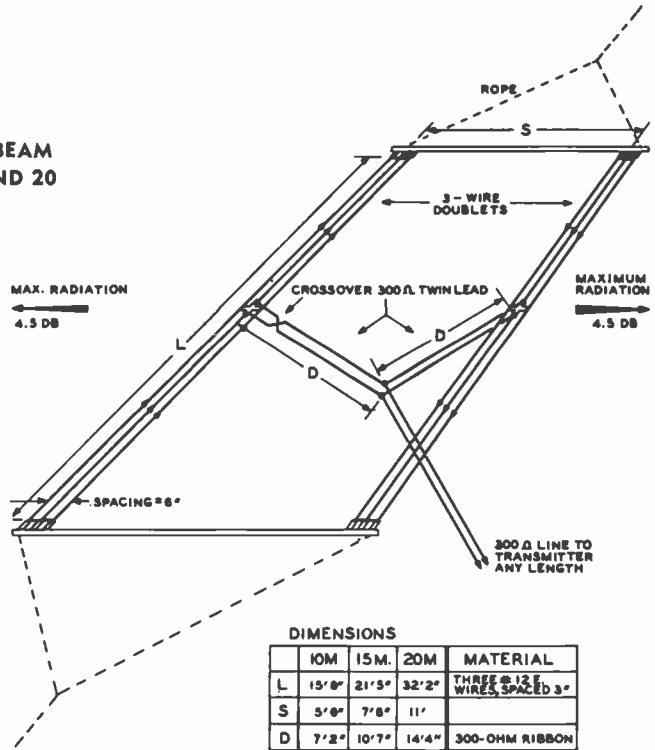

greater directivity gain while maintaining a bidirectional characteristic. However, it must be kept in mind that to realize a worthwhile increase in directivity and gain while maintaining a bidirectional pattern the individual arrays must be spaced sufficiently to reduce the mutual impedances to a negligible value.

When two flat-top beams, for instance, are placed one above the other or end to end, a center spacing on the order of one wavelength is required in order to achieve a worthwhile increase in gain, or approximately 3 db.

Thus it is seen that, while maximum gain occurs with two stacked dipoles at a spacing of about 0.7 wavelength and the space directivity gain is approximately 5 db over one element under these conditions; the case of two flat-top or parasitic arrays stacked one above the other is another story. Maximum gain will occur at a greater spacing, and the gain over one array will not appreciably exceed 3 db.

When two broadside curtains are placed one ahead of the other in end-fire relationship, the aggregate mutual impedance between the two curtains is such that considerable spacing is required in order to realize a gain approaching 3 db (the required spacing being a function of the size of the curtains). While it is true that a space-directivity gain of approximately 4 db can be obtained by placing one half-wave dipole an eighth wavelength ahead of another and feeding them 180 degrees out of phase, a gain of less than 1 db is obtained when the same procedure is applied to two large broadside curtains. To obtain a gain of approximately 3 db and retain a bidirectional pattern, a spacing of many wavelengths is required between two large curtains placed one ahead of the other.

A different situation exists, however, when one driven curtain is placed ahead of an identical one and the two are phased so as to give a unidirectional pattern. When a unidirectional pattern is obtained, the gain

over one curtain will be approximately 3 db regardless of the spacing. For instance, two large curtains one placed a quarter wavelength ahead of the other may have a space-directivity gain of only 0.5 db over one curtain when the two are driven 180 degrees out of phase to give a bidirectional pattern (the type of pattern obtained with a single curtain). However, if they are driven in phase quadrature (and with equal currents) the gain is approximately 3 db.

The directivity gain of a composite array also can be explained on the basis of the directivity patterns of the component arrays alone, but it entails a rather complicated picture. It is sufficient for the purpose of this discussion to generalize and simplify by saying that the greater the directivity of an end-fire array, the farther an identical array must be spaced from it in broadside relationship to obtain optimum performance; and the greater the directivity of a broadside array, the farther an identical array must be spaced from it in end-fire relationship to obtain optimum performance and retain the bidirectional characteristic.

It is important to note that while a bidirectional end-fire pattern is obtained with two driven dipoles when spaced anything under a half wavelength, and while the proper phase relationship is 180 degrees regardless of the spacing for all spacings not exceeding one half wavelength, the situation is different in the case of two curtains placed in end-fire relationship to give a bidirectional pattern. For maximum gain at zero wave angle, the curtains should be spaced an odd multiple of one-half wavelength and driven so as to be 180 degrees

out of phase, or spaced an even multiple of one half wavelength and driven in the same phase. The optimum spacing and phase relationship will depend on the directivity pattern of the individual curtains used alone, and as previously noted the optimum spacing increases with the size and directivity of the component arrays.

A concrete example of a combination broadside and end-fire array is two Lazy H arrays spaced along the direction of maximum radiation by a distance of four wavelengths and fed in phase. The space-directivity gain of such an arrangement is slightly less than 9 db. However, approximately the same gain can be obtained by juxtaposing the two arrays side by side or one over the other in the same plane, so that the two combine to produce, in effect, one broadside curtain of twice the area. It is obvious that in most cases it will be more expedient to increase the area of a broadside array than to resort to a combination of end-fire and broadside directivity.

One exception, of course, is where two curtains are fed in phase quadrature to obtain a unidirectional pattern and space-directivity gain of approximately 3 db with a spacing between curtains as small as one quarter wavelength. Another exception is where very low angle radiation is desired and the maximum pole height is strictly limited. The two aforementioned Lazy H arrays when placed in endfire relationship will have a considerably lower radiation angle than when placed side by side if the array elevation is low, and therefore may *under some conditions* exhibit appreciably practical signal gain.

VHF and UHF Antennas

The *very-high-frequency* or *vhf* frequency range is defined as that range falling between 30 and 300 MHz. The *ultrahigh-frequency* or *uhf range* is defined as falling between 300 and 3000 MHz. This chapter will be devoted to the design and construction of antenna systems for operation on the amateur 50-, 144-, 235-, and 420-MHz bands. Although the basic principles of antenna operation are the same for all frequencies, the shorter physical length of a wave in this frequency range and the differing modes of signal propagation make it possible and expedient to use antenna systems different in design from those used in the range from 3 to 30 MHz.

23-1 Antenna Requirements

Any type of antenna system usable on the lower frequencies *may* be used in the vhf and uhf bands. In fact, simple nondirective half-wave or quarter-wave vertical antennas are very popular for general transmission and reception from all directions, especially for short-range work. But for serious vhf or uhf work the use of some sort of directional antenna array is a necessity. In the first place, when the transmitter power is concentrated into a narrow beam the apparent transmitter power at the receiving station is increased many times. A "billboard" array or a Sterba curtain having a gain of

16 db will make a 25-watt transmitter sound like a kilowatt at the other station. Even a much simpler and smaller three- or four-element parasitic array having a gain of 7 to 10 db will produce a marked improvement in the received signal at the other station.

However, as all vhf and uhf workers know, the most important contribution of a high-gain antenna array is in reception. If a remote station cannot be heard it obviously is impossible to make contact. The limiting factor in vhf and uhf reception is in almost every case the noise generated within the receiver itself. Atmospheric noise is almost nonexistent and ignition interference can almost invariably be reduced to a satisfactory level through the use of an effective noise limiter. Even with a grounded-grid or neutralized triode first stage in the receiver, the noise contribution of the first tuned circuit in the receiver will be relatively large. Hence it is desirable to use an antenna system which will deliver the greatest signal voltage to the first tuned circuit for a given field strength at the receiving location.

Since the field intensity being produced at the receiving location by a remote transmitting station may be assumed to be constant, the receiving antenna which intercepts the greatest amount of wave front (assuming that the polarization and directivity of the receiving antenna is proper, will be the antenna which gives the best received signal-to-noise ratio. An antenna which has two

square wavelengths of effective area will pick up twice as much signal power as one which has one square wavelength area, assuming the same general type of antenna and that both are directed at the station being received. Many instances have been reported where a frequency band sounded completely dead with a simple dipole receiving antenna but when the receiver was switched to a three-element or larger array a considerable amount of activity from 80 to 160 miles distant was heard.

Transmission Lines Transmission lines to vhf and uhf antenna systems may be either of the parallel-conductor or coaxial-conductor type. Coaxial line is recommended for short runs and closely spaced open wire line for longer runs. Waveguides may be used under certain conditions for frequencies greater than perhaps 1500 MHz but their dimensions become excessively great for frequencies much below this value. Nonresonant transmission lines will be found to be considerably more efficient on these frequencies than those of the resonant type. It is wise to use the very minimum length of transmission line possible since transmission-line losses at frequencies above about 100 MHz mount very rapidly.

Open lines should preferably be spaced closer than is common for longer wavelengths, since a few inches are an appreciable fraction of a wavelength at 2 meters. Radiation from the line will be greatly reduced if 1-inch or 1½-inch spacing is used, rather than the wider spacing used in the uhf region.

Ordinary TV-type 300-ohm ribbon or the new coaxial *foamflex* line may be used on the 2-meter band for feeder lengths of about 50 feet or less. For longer runs, either the uhf or vhf TV open-wire lines may be used with good over-all efficiency. The vhf line is satisfactory for use on the amateur 420-MHz band.

Antenna Changeover It is recommended that the same antenna be used for transmitting and receiving in the vhf and uhf range. An ever-present problem in this connection, however, is the antenna changeover relay. Reflections at the antenna

changeover relay become of increasing importance as the frequency of transmission is increased. When coaxial cable is used as the antenna transmission line, satisfactory coaxial antenna changeover relays with low reflection can be used.

On the 235- and 420-MHz amateur bands, the size of the antenna array becomes quite small, and it is practical to mount two identical antennas side by side. One of these antennas is used for the transmitter, and the other antenna for the receiver. Separate transmission lines are used, and the antenna relay may be eliminated.

Effect of Feed System on Radiation Angle A vertical radiator for general-coverage uhf use should be made either ¼- or ½-wavelength long. Longer vertical antennas do not have their maximum radiation at right angles to the line of the radiator (unless co-phased), and, therefore, are not practical for use where greatest possible radiation parallel to the earth is desired.

Unfortunately, a feed system which is not perfectly balanced and does some radiating, not only robs the antenna itself of that much power, but *distorts the radiation pattern of the antenna*. As a result, the pattern of a vertical radiator may be so altered that the radiation is bent upwards slightly, and the amount of power leaving the antenna parallel to the earth is greatly reduced. A vertical half-wave radiator fed at the bottom by a quarter-wave stub is a good example of this; the slight radiation from the matching section decreases the power radiated parallel to the earth by nearly 10 db. It is important, therefore, to decouple the transmission line from the antenna with a balun or other matching device to keep current from flowing on the outside of the shield of a coaxial line.

Radiator Cross Section In the vhf region, aluminum tubing is commonly used for dipoles since the radiator length is so short that the expense of large-diameter conductor is relatively small, even though tubing of 1-inch cross section is used. With such conductors, the antenna will tune much more broadly, and often a broad resonance characteristic is

desirable. This is particularly true when an antenna or array is to be used over an entire amateur band.

It should be kept in mind that with such large-cross-section radiators, the resonant length of the radiator will be somewhat shorter, being only slightly greater than 0.90 of a half wavelength for a dipole when large-diameter pipe is used above 100 MHz.

Insulation The matter of insulation is of prime importance at very-high frequencies. Many insulators that have very low losses as high as 30 MHz show up rather poorly at frequencies above 100 MHz. Even the low-loss ceramics are none too good where the r-f voltage is high. One of the best and most practical insulators for use at this frequency is polystyrene. It has one disadvantage, however, in that it is subject to fracture and to deformation in the presence of heat.

It is common practice to design vhf and uhf antenna systems so that the various radiators are supported only at points of relatively low voltage; the best insulation, obviously, is air. The voltages on properly operated untuned feed lines are not high, and the question of insulation is not quite so important, though insulation still should be of good grade.

Antenna Polarization Commercial broadcasting in the U.S.A. for both frequency modulation and television in the vhf range has been standardized on horizontal polarization. One of the main reasons for this standardization is the fact that ignition interference is reduced through the use of a horizontally polarized receiving antenna. Amateur practice, however, is divided between horizontal and vertical polarization in the vhf and uhf range. Mobile stations are often vertically polarized due to the physical limitations imposed by the automobile antenna installation. Most of the stations doing intermittent or occasional work on these frequencies use a simple ground-plane vertical antenna for both transmission and reception. However, those stations doing serious work and striving for maximum-range contacts on the 50- and 144-MHz bands almost invariably use horizontal polarization.

TABLE 1. WAVELENGTHS AND ANTENNA DIMENSIONS

Frequency (MHZ)	1/2 Wave-length	1/4 Wave-length	1/2-Wave Dipole	0.2 Wave-length
50.5	122	61	109.5	47"
51.5	120	60	107.5	
52.5	118	59	105.5	
53.5	116	58	103.5	
144	41.0	20.50	38.8	15 1/2"
145	40.75	20.36	38.6	
146	40.5	20.25	38.4	
147	40.25	20.12	38.2	
148	40.0	20.00	38.0	
221	26.5	13.25	25.3	10 3/4"
222	26.4	13.20	25.2	
223	26.3	13.15	25.1	
224	26.2	13.10	25.0	
420	13.70	6.90	12.90	5 3/8"
430	13.65	6.82	12.75	
440	13.50	6.75	12.60	
450	13.35	6.68	12.45	

1—All dimensions in inches.

2—For parasitic director, multiply dipole length by 0.95.

3—For parasitic reflector, multiply dipole length by 1.05.

4—For additional directors, multiply dipole length by 0.94.

5—Use 1/2" tubing for 50 MHz, 1/4" tubing for 144 MHz, 1/8" tubing for 222 and 432 MHz arrays.

Experience has shown that there is a great attenuation in signal strength when using crossed polarization (transmitting antenna with one polarization and receiving antenna with the other) for all normal ground-wave contacts on these bands. When contacts are being made through sporadic-E reflection, however, the use of crossed polarization seems to make no discernible difference in signal strength. So the operator of a station doing vhf work (particularly on the 50-MHz band) is faced with a problem: If contacts are to be made with all stations doing work on the same band, provision must be made for operation on both horizontal and vertical polarization. This problem has been solved in many cases through the construction of an antenna array that may be revolved in the plane of polarization in addition to being capable of rotation in the azimuth plane.

An alternate solution to the problem which involves less mechanical construction is simply to install a good ground-plane vertical antenna for all vertically-polarized work, and then to use a multielement horizontally polarized array for DX work.

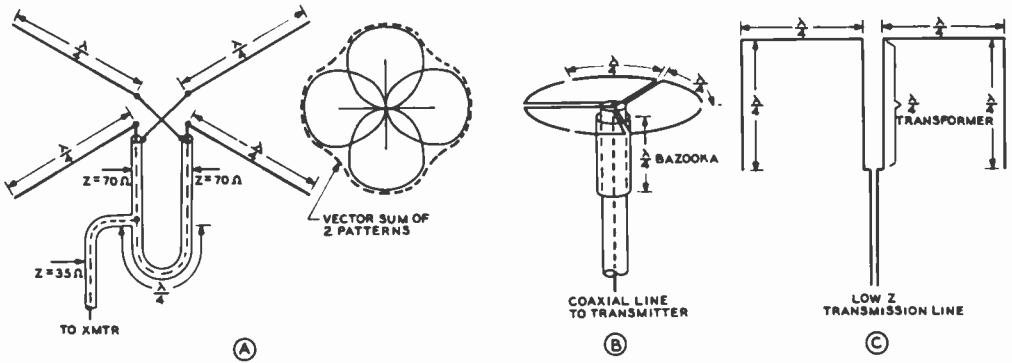

Figure 1

THREE NONDIRECTIONAL HORIZONTALLY POLARIZED ANTENNAS

VHF Antenna Dimensions Listed in Table 1 are representative dimensions for the elements of vhf and uhf antenna arrays of the parasitic or collinear type. Since the length-to-diameter ratio of antennas above 100 MHz or so is somewhat smaller than that of high-frequency arrays, and because the arrays are physically smaller, dimensions are generally given in inches, based on the following formula:

$$\text{Dipole length (inches)} = \frac{5600}{f_{\text{MHz}}}$$

The dimensions for small (3, 4, or 5 element) Yagis may be derived from Table 1, based on elements of the listed diameters and using a nominal spacing of 0.2 wavelength. If other element spacings are to be used, the reflector and director elements will have to be readjusted accordingly. Closer reflector driven-element spacing will call for a slightly shorter reflector for optimum gain. Closer director driven-element spacing will call for a slightly longer director for optimum gain. Generally speaking, anything closer to 0.2-wavelength spacing in Yagi arrays tends to reduce the bandwidth, reduce the driven-element impedance, and increase the front-to-back ratio.

Vhf and uhf elements may be made of small-diameter aluminum tubing, or (in the case of the 432-MHz band) 1/8" diam-

eter aluminum clothesline wire. The parasitic element should not be painted, as this tends to detune the element. A light coat of Krylon plastic spray may be used to protect the element against weather.

23-2 Simple Horizontally Polarized Antennas

Antenna systems which do not concentrate radiation at the very low elevation angles are not recommended for vhf and uhf work. It is for this reason that the horizontal dipole and horizontally disposed collinear arrays are generally unsuitable for work on these frequencies. Arrays using broadside or end-fire elements do concentrate radiation at low elevation angles and are recommended for vhf work. Arrays such as the lazy H, Sterba curtain, log-periodic beam, and arrays with parasitically excited elements are recommended for this work. Dimensions for the first two types of arrays may be determined from the data given in the previous chapter, and reference may be made to the *Table of Wavelengths* given in this chapter.

Arrays using vertically stacked horizontal dipoles, such as are used by commercial television and f-m stations, are capable of giving high gain *without* a sharp horizontal radiation pattern. If sets of crossed dipoles, as shown in figure 1A, are fed 90° out of phase the resulting system is called a *turn-*

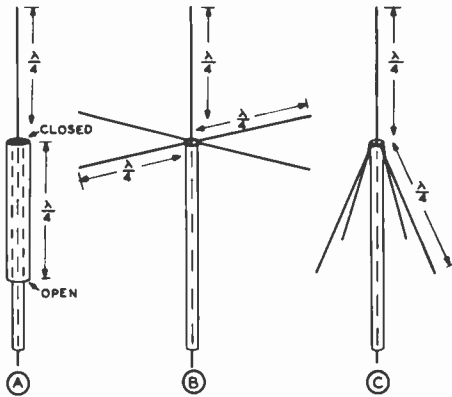

Figure 2

THREE VERTICALLY POLARIZED LOW-ANGLE RADIATORS

Shown at A is the "sleeve" or "hypodermic" type of radiator. At B is shown the ground-plane vertical, and C shows a modification of this antenna system which increases the feed-point impedance to a value such that the system may be fed directly from a coaxial line with no standing waves on the feed line.

stile antenna. The 90° phase difference between sets of dipoles may be obtained by feeding one set of dipoles with a feed line which is one-quarter wave longer than the feed line to the other set of dipoles. The field strength broadside to one of the dipoles is equal to the field from that dipole alone. The field strength at a point at any other angle is equal to the vector sum of the fields from the two dipoles at that angle. A nearly circular horizontal pattern is produced by this antenna.

A second antenna producing a uniform, horizontally polarized pattern is shown in figure 1B. This antenna employs three dipoles bent to form a circle. All dipoles are excited in phase, and are center fed. A bazooka is included in the system to prevent unbalance in the coaxial feed system.

A third nondirectional antenna is shown in figure 1C. This simple antenna is made of two half-wave elements, of which the end quarter wavelength of each is bent back 90 degrees. The pattern from this antenna is very much like that of the turnstile antenna. The field from the two quarter-wave sections that are bent back are additive because they are 180 degrees out of phase and

are a half wavelength apart. The advantage of this antenna is the simplicity of its feed system and construction.

23-3 Simple Vertical-Polarized Antennas

For general coverage with a single antenna, a single vertical radiator is commonly employed. A two-wire open transmission line is not suitable for use with this type antenna, and coaxial polyethylene feed line such as RG-8/U is to be recommended. Three practical methods of feeding the radiator with concentric line, with a minimum of current induced in the outside of the line, are shown in figure 2. Antenna A is known as the *sleeve antenna*, the lower half of the radiator being a large piece of pipe up through which the concentric feed line is run. At B is shown the ground-plane vertical, and at C a modification of this latter antenna. In many cases, the antennas of illustrations A and C have a set of quarter-wave radials placed beneath the array to decouple it from the transmission line.

The radiation resistance of the ground-plane vertical is approximately 30 ohms, which is not a standard impedance for coaxial line. To obtain a good match, the first quarter wavelength of feeder may be of 52 ohms surge impedance, and the remainder of the line of approximately 75 ohms impedance. Thus, the first quarter-wave section of line is used as a matching transformer, and a good match is obtained.

In actual practice the antenna would consist of a quarter-wave rod, mounted by means of insulators atop a pole or pipe mast. Elaborate insulation is not required, as the voltage at the lower end of the quarter-wave radiator is very low. Self-supporting rods from 0.25 to 0.28 wavelength are extended out, as shown in the illustration, and connected together. Since the point of connection is effectively at ground potential, no insulation is required; the horizontal rods may be bolted directly to the supporting pole or mast, even if of metal. The coaxial line should be of the low-loss type especially designed for vhf use. The shield connects to the junction of the radials, and the inner

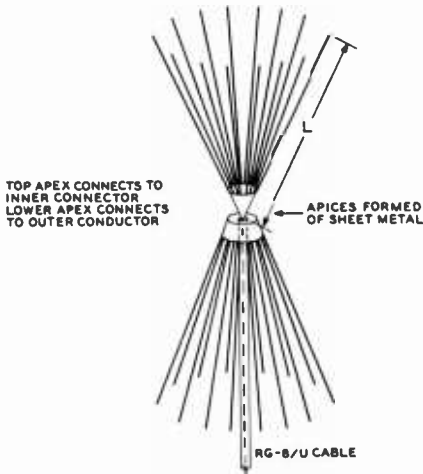

Figure 3

THE DOUBLE SKELETON CONE ANTENNA

A skeleton cone has been substituted for the single element radiator of figure 2C. This greatly increases the bandwidth. If at least 10 elements are used for each skeleton cone and the angle of revolution and element length are optimized, a low SWR can be obtained over a frequency range of at least two octaves. To obtain this order of bandwidth, element length L should be approximately 0.2 wavelength at the lower frequency end of the band, and the angle of revolution optimized for the lowest maximum SWR within the frequency range to be covered. A greater improvement in the impedance-frequency characteristic can be achieved by adding elements than by increasing the diameter of the elements. With only 3 elements per "cone" and a much smaller angle of revolution a low SWR can be obtained over a frequency range of approximately 1.3 to 1.0 when the element lengths are optimized.

conductor to the bottom end of the vertical radiator. An antenna of this type is moderately simple to construct and will give a good account of itself when fed at the lower end of the radiator directly by the 52-ohm RG-8/U coaxial cable. Theoretically the standing-wave ratio will be approximately 1.5-to-1 but in practice this moderate SWR produces no deleterious effects.

The modification shown in figure 2C permits matching to a standard 50- or 70-ohm flexible coaxial cable without a linear transformer. If the lower rods hug the line and supporting mast rather closely, the feed-point impedance is about 70 ohms. If they are bent out to form an angle of about 30°

with the support pipe the impedance is about 50 ohms.

The number of radial legs used in a ground-plane antenna of either type has an important effect on the feed-point impedance and on the radiation characteristics of the antenna system. Experiment has shown that three radials is the minimum number that should be used, and that increasing the number of radials above six adds substantially nothing to the effectiveness of the antenna and has no effect on the feed-point impedance. Measurement shows, however, that the radials should be slightly longer than one-quarter wave for best results. A length of 0.26 wavelength has been found to be the optimum value. This means that the radials for a 50-MHz ground-plane vertical antenna should be 62" in length.

Double Skeleton Cone Antenna The bandwidth of the antenna of figure 2C can be increased considerably by substituting several space-tapered rods for the single radiating element, so that the "radiator" and skirt are similar. If a sufficient number of rods are used in the skeleton cones and the angle of revolution is optimized for the particular type of feed line used, this antenna exhibits a very low SWR over a 2-to-1 frequency range. Such an arrangement is illustrated schematically in figure 3.

A Nondirectional Vertical Array Half-wave elements may be stacked in the vertical plane to provide a nondirectional pattern with good horizontal gain. An array made up of four half-wave vertical elements is shown in figure 4A. This antenna provides a circular pattern with a gain of about 4.5 db over a vertical dipole. It may be fed with 300-ohm TV-type line. The feed line should be conducted in such a way that the vertical portion of the line is at least one-half wavelength away from the vertical antenna elements. A suitable mechanical assembly is shown in figure 4B for the 144- and 235-MHz amateur bands.

A Stacked Sleeve Antenna for 144 MHz The sleeve antenna makes a good omnidirectional array for 144 MHz in areas

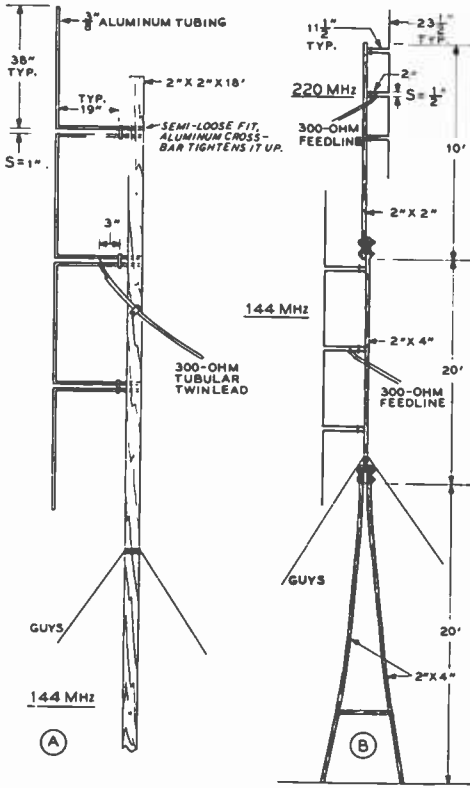

Figure 4

NONDIRECTIONAL ARRAYS FOR 144 AND 235 MHz

On right is shown a two-band installation. For portable use, the whole system may easily be disassembled and carried on a luggage rack atop a car.

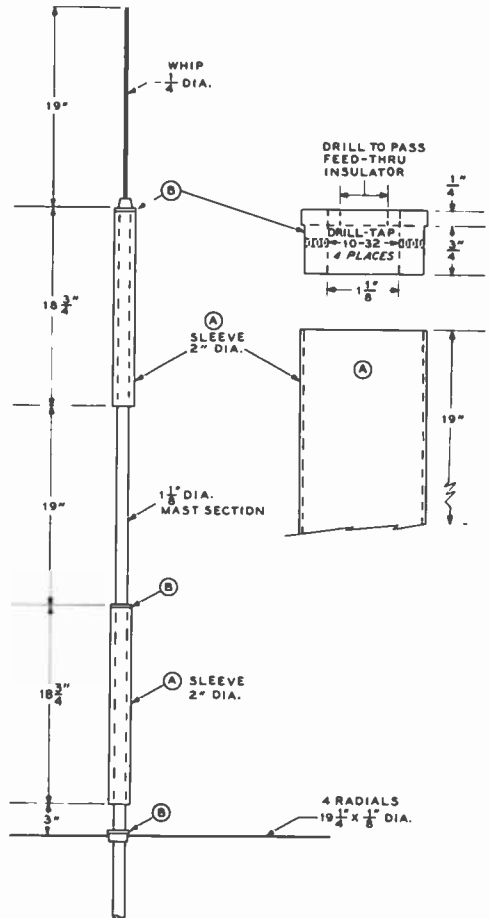

Figure 5

SLEEVE ANTENNA FOR 144 MHz

Stacked dipoles provide nondirectional coverage with low-angle radiation. The top whip is fed by a coaxial line passed up through the mast section and is insulated from remainder of the antenna structure. Lower dipole is composed of mast section and matching skirt which is grounded to the mast at the top. Bottoms of both skirts are free. Radials beneath bottom section impede flow of antenna current on outside of coaxial line.

where vertical polarization is used. A double stack, such as illustrated in figure 5, will provide low-angle radiation and a power gain of about 3 decibels. The array is designed to be fed with a 50-ohm coaxial transmission line.

The antenna is built on an eight-foot length of aluminum TV mast section, 1 1/8" diameter. A quarter-wavelength whip extends from the top of the assembly, and two sleeves are mounted to the mast section below the whip. Both sleeves are electrically connected to the mast at their tops, and the bottom sleeve is shock-excited by the top antenna array, which functions as

a simple dipole. Directly below the sleeves are mounted four quarter-wave horizontal radials which decouple the stacked antenna from the outer shield of the coaxial transmission line.

Antenna construction is straightforward and simple. The top of the mast is closed with an aluminum plug (B) having a

ceramic feedthrough insulator mounted in it. The vertical whip attaches to the insulator, as does the center conductor of the coaxial feedline. The outer shield of the line is grounded to the mast section at the insulator. The outer sleeve (A) is attached to the mast section by means of machine screws tapped into the aluminum plug.

The lower sleeve is attached to the mast in a similar manner, as shown in the drawing. The radials, made of aluminum clothesline wire are threaded and screwed to an aluminum mounting cylinder (similar to B) which encircles the mast.

Three aluminum fittings (B) are required: one for the top sleeve, one for the lower sleeve, and one for the radials. The top fitting is shown in figure 5. The center one is similar, except that it is drilled to pass the mast section. The fitting for the radials is similar to the center one, except that the $\frac{1}{4}$ -inch lip at the top is omitted.

The length of the fitting is such so that the inner resonant portion of the sleeve is slightly shorter than the outer section. The outer section acts as a portion of the antenna and the inner section acts as a decoupling transformer. The resonant lengths are different for each case, and the length of the fitting makes up the electrical difference.

The sleeves are free at the lower ends, with no connection or support at this point. Care must be taken to make the assembly waterproof, as an accumulation of moisture in the sleeve may detune it. Plugs at the bottom of the sleeves, therefore, are not advised.

The 50-ohm coaxial transmission line runs up the inside of the mast to the top fitting where the outer shield is grounded to the structure by means of a washer placed beneath the feedthrough insulator. The shield is soldered to a lug of the washer, which may be cut from thin brass or copper shim stock.

When fed with a 50-ohm transmission line, the measured SWR across the 144-MHz band is less than 2/1, and better than 1.5/1 at the center frequency of 146 MHz.

23-4 The Discone Antenna

The *Discone* antenna is a vertically polarized omnidirectional radiator which has very

broad band characteristics and permits a simple, rugged structure. This antenna presents a substantially uniform feed-point impedance, suitable for direct connection of a coaxial line, over a range of several octaves. Also, the vertical pattern is suitable for ground-wave work over several octaves, the gain varying only slightly over a very wide frequency range.

A Discone antenna suitable for multiband amateur work in the uhf/vhf range is shown schematically in figure 6. The distance (D) should be made approximately equal to a free-space quarter wavelength at the lowest operating frequency. The antenna then will perform well over a frequency range of at least 8 to 1. At certain frequencies within this range the vertical pattern will tend to rise slightly, causing a slight reduction in gain at zero angular elevation, but the reduction is very slight.

Below the frequency at which the slant height of the conical skirt is equal to a free-space quarter wavelength the standing-wave ratio starts to climb, and below a frequency approximately 20 percent lower than this

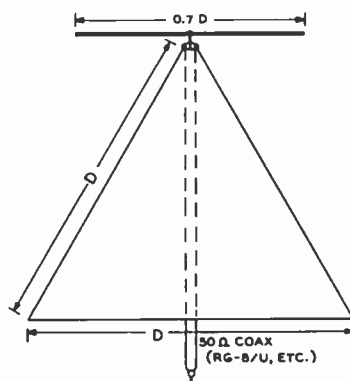

Figure 6

THE DISCONE BROADBAND RADIATOR

This antenna system radiates a vertically polarized wave over a very wide frequency range. The "disc" may be made of solid metal sheet, a group of radials, or wire screen; the "cone" may best be constructed by forming a sheet of thin aluminum. A single antenna may be used for operation on the 50-, 144-, and 220-MHz amateur bands. The dimension D is determined by the lowest frequency to be employed, and is given in figure 7.

the standing-wave ratio climbs very rapidly. This is termed the *cutoff frequency* of the antenna. By making the slant height approximately equal to a free-space quarter wavelength at the lowest frequency employed (refer to figure 7), an SWR of less than 1.5 will be obtained throughout the operating range of the antenna.

The Discone antenna may be considered as a cross between an electromagnetic horn and an inverted ground-plane unipole antenna. It looks to the feed line like a properly terminated high-pass filter.

Construction Details The top disc and the conical skirt may be fabricated either from sheet metal, screen (such as "hardware cloth"), or 12 or more "spine" radials. If screen is used, a supporting framework of rod or tubing will be necessary for mechanical strength except at the higher frequencies. If spines are used, they should be terminated on a stiff ring for mechanical strength, except at the higher frequencies.

The top disc is supported by means of three insulating pillars fastened to the skirt. Either polystyrene or low-loss ceramic is suitable for the purpose. The apex of the conical skirt is grounded to the supporting mast and to the outer conductor of the coaxial line. The line is run down through the supporting mast. An alternative arrangement, one suitable for certain mobile applications, is to fasten the base of the skirt directly to an effective ground plane such as the top of an automobile.

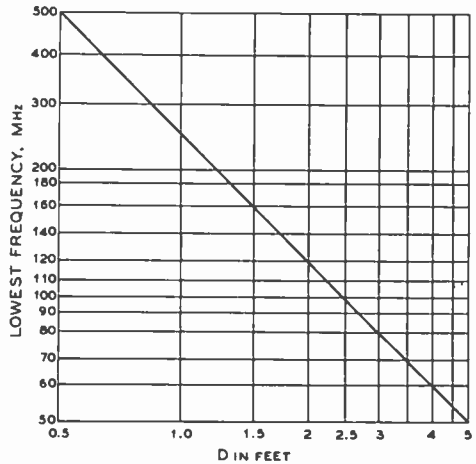

Figure 7

DESIGN CHART FOR THE DISCONE ANTENNA

phase. The circularly polarized wave may be either "left handed" or "right handed," depending on whether the vertically polarized component leads or lags the horizontal component.

A circularly polarized antenna will respond to any plane polarized wave whether horizontally polarized, vertically polarized,

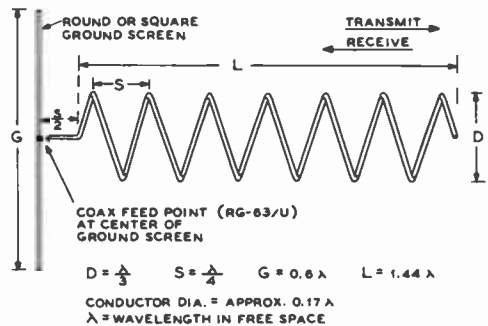

Figure 8

THE HELICAL BEAM ANTENNA

This type of directional antenna system gives excellent performance over a frequency range of 1.7 to 1.8 to 1. Its dimensions are such that it is ordinarily not practical, however, for use as a rotatable array on frequencies below about 100 MHz. The center conductor of the feed line should pass through the ground screen for connection to the feed point. The outer conductor of the coaxial line should be grounded to the ground screen.

23-5 Helical Beam Antennas

Most vhf and uhf antennas are either vertically polarized or horizontally polarized (plane polarization). However, circularly polarized antennas having interesting characteristics which may be useful for certain applications. The installation of such an antenna can effectively solve the problem of horizontal versus vertical polarization.

A circularly polarized wave has its energy divided equally between a vertically polarized component and a horizontally polarized component, the two being 90 degrees out of

or diagonally polarized. Also, a circular polarized wave can be received on a plane polarized antenna, regardless of the polarization of the latter.

When using circularly polarized antennas at *both* ends of the circuit, however, both must be left handed or both must be right handed. This offers some interesting possibilities with regard to reduction of interference. At the time of writing, there has been no standardization of the "twist" for general amateur work.

Perhaps the simplest antenna configuration for a directional beam antenna having circular polarization is the *helical beam* which consists simply of a helix working against a ground plane and fed with coaxial line. In the uhf and the upper vhf range the physical dimensions are sufficiently small to permit construction of a rotatable structure without much difficulty.

When the dimensions are optimized, the characteristics of the helical beam antenna are such as to qualify it as a broadband antenna. An optimized helical beam shows little variation in the pattern of the main lobe and a fairly uniform feed-point impedance averaging approximately 125 ohms over a frequency range of as much as 1.7 to 1. The direction of "electrical twist" (right or left handed) depends on the direction in which the helix is wound.

A six-turn helical beam is shown schematically in figure 8. The dimensions shown will give good performance over a frequency range of plus or minus 20 percent of the design frequency. This means that the dimensions are not especially critical when the array is to be used at a single frequency or over a narrow band of frequencies, such as an amateur band. At the design frequency the beam width is about 50 degrees and the power gain about 12 db, referred to a non-directional circularly polarized antenna.

The Ground Screen For the frequency range 100 to 500 MHz a suitable ground screen can be made from "chicken wire" poultry netting of 1-inch mesh, fastened to a round or square frame of either metal or wood. The netting should be of the type that is galvanized *after* weaving. A small, sheet-metal ground plate of

diameter equal to approximately $D/2$ should be centered on the screen and soldered to it. Tin, galvanized iron, or sheet copper is suitable. The outer conductor of the RG-63/U (125-ohm) coax is connected to this plate, and the inner conductor contacts the helix through a hole in the center of the plate. The end of the coax should be taped with *Scotch* electrical tape to keep water out.

The Helix It should be noted that the beam proper consists of six full turns. The start of the helix is spaced a distance of $S/2$ from the ground screen, and the conductor goes directly from the center of the ground screen to the start of the helix.

Aluminum tubing in the 2014 alloy grade is suitable for the helix. Alternatively, lengths of the relatively soft aluminum electrical conduit may be used. In the vhf range it will be necessary to support the helix on either two or four wooden longerons in order to achieve sufficient strength. The longerons should be of the smallest cross section which provides sufficient rigid-

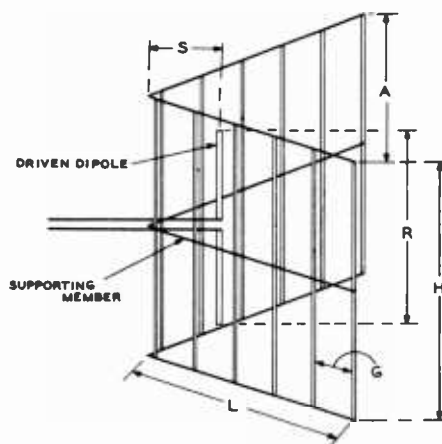

Figure 9

CONSTRUCTION OF THE CORNER REFLECTOR ANTENNA

Such an antenna is capable of giving high gain with a minimum of complexity in the radiating system. It may be used either with horizontal or vertical polarization. Design data for the antenna is given in the Corner Reflector Design Table.

ity, and should be given several coats of varnish. The ground plane butts against the longerons and the whole assembly is supported from the balance point if it is to be rotated.

Aluminum tubing in the larger diameters ordinarily is not readily available in lengths greater than 12 feet. In this case several lengths can be spliced by means of short telescoping sections and sheet-metal screws.

The tubing is closewound on a drum and then spaced to give the specified pitch. Note that the length of one complete turn when spaced is somewhat greater than the circumference of a circle having the diameter D.

Broad-Band Helical Beam 144- to 225-MHz
A highly useful vhf helical beam which will receive signals with good gain over the complete frequency range from 144 through 255 MHz may be constructed by using the following dimensions (180 MHz design center):

- D 22 in.
- S 16½ in.
- G 53 in.
- Tubing o.d. 1 in.

The D and S dimensions are to the center of the tubing. These dimensions must be held rather closely, since the range from 144 through 255 MHz represents just about the practical limit of coverage of this type of antenna system.

High-Band TV Coverage Note that an array constructed with the above dimensions will give unusually good high-band TV reception in addition to covering the 144- and 220-MHz amateur bands and the taxi and police services.

On the 144-MHz band the beam width is approximately 60 degrees to the half-power points, while the power gain is approximately 11 db over a nondirectional circularly polarized antenna. For high-band TV coverage the gain will be 12 to 14 db, with a beam width of about 50 degrees, and on the 220-MHz amateur band the beam width will be about 40 degrees with a power gain of approximately 15 db.

The antenna system will receive vertically polarized or horizontally polarized signals with equal gain over its entire frequency range. Conversely, it will transmit signals over the same range, which then can be received with equal strength on either horizontally polarized or vertically polarized receiving antennas. The standing-wave ratio will be very low over the complete frequency range if RG-63/U coaxial feed line is used.

23-6 The Corner-Reflector and Horn-Type Antennas

The corner-reflector antenna is a good directional radiator for the vhf and uhf region. The antenna may be used with the radiating element vertical, in which case the directivity is in the horizontal or azimuth plane, or the system may be used with the driven element horizontal, in which case the radiation is horizontally polarized, and most of the directivity is in the vertical plane. With the antenna used as a horizontally polarized radiating system the array is a very good low-angle beam array although the nose of the horizontal pattern is still quite sharp. When the radiator is oriented vertically the corner reflector operates very satisfactorily as a direction-finding antenna.

TABLE 2. CORNER-REFLECTOR DESIGN DATA

Corner Angle	Freq. Band, MHz	R	S	H	A	L	G	Feed Imped.	Approx. Gain, db
90	50	110"	82"	140"	200"	230"	18"	72	10
60	50	110"	115"	140"	230"	230"	18"	70	12
60	144	38"	40"	48"	100"	100"	5"	70	12
60	220	24.5"	25"	30"	72"	72"	3"	70	12
60	420	13"	14"	18"	36"	36"	screen	74	12

NOTE: Refer to figure 9 for construction of corner-reflector antenna.

Design data for the corner-reflector antenna is given in figure 9 and in Table 2, *Corner-Reflector Design Data*. The planes which make up the reflecting corner may be made of solid sheets of copper or aluminum for the uhf bands, although spaced wires with the ends soldered together at top and bottom may be used as the reflector on the lower frequencies. Copper screen may also be used for the reflecting planes.

The values of spacing given in the corner-reflector chart have been chosen such that the center impedance of the driven element would be approximately 70 ohms. This means that the element may be fed directly with 70-ohm coaxial line, or a quarter-wave matching transformer such as a Q-section may be used to provide an impedance match between the center impedance of the element and a 460-ohm line constructed of No. 12 wire spaced 2 inches.

In many uhf antenna systems, waveguide transmission lines are terminated by *pyramidal horn* antennas. These horn antennas (figure 10A) will transmit and receive either horizontally or vertically polarized waves. The use of waveguides at 144 and 235 MHz, however, is out of the question because of the relatively large dimensions needed for a waveguide operating at these low frequencies.

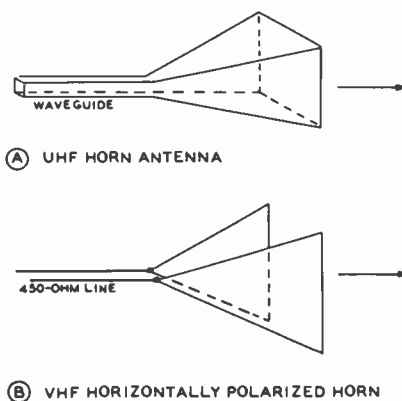
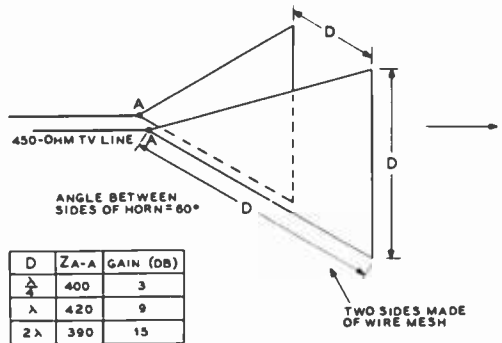

Figure 10

TWO TYPES OF HORN ANTENNAS

The "two-sided horn" of illustration B may be fed by means of an open-wire transmission line.



D	Z A-A	GAIN (DB)
$\frac{\lambda}{4}$	400	3
λ	420	9
2λ	390	15

Figure 11

THE 60° HORN ANTENNA FOR USE ON FREQUENCIES ABOVE 144 MHz

A modified type of horn antenna may still be used on these frequencies, since only one particular plane of polarization is of interest to the amateur. In this case, the horn antenna can be simplified to two triangular sides of the pyramidal horn. When these two sides are insulated from each other, direct excitation at the apex of the horn by a two-wire transmission line is possible.

In a normal pyramidal horn, all four triangular sides are covered with conducting material, but when horizontal polarization alone is of interest (as in amateur work) only the *vertical* areas of the horn need be used. If vertical polarization is required, only the *horizontal* areas of the horn are employed. In either case, the system is unidirectional, away from the apex of the horn. A typical horn of this type is shown in figure 10B. The two metallic sides of the horn are insulated from each other, and the sides of the horn are made of small mesh "chicken wire" or copper window screening.

A pyramidal horn is essentially a high-pass device whose low-frequency cutoff is reached when a side of the horn is $\frac{1}{2}$ wavelength. It will work up to infinitely high frequencies, the gain of the horn increasing by 6 db every time the operating frequency is doubled. The power gain of such a horn compared to a half-wave dipole at frequencies higher than cutoff is:

$$\text{Power gain (db)} = \frac{8.4 A^2}{\lambda^2}$$

where A is the frontal area of the mouth of the horn. For the 60-degree horn shown in figure 8B the formula simplifies to:

Power gain (db) = $8.4 D^2$, when D is expressed in terms of wavelength.

When D is equal to one wavelength, the power gain of the horn is approximately 9 db. The gain and feed-point impedance of the 60-degree horn are shown in figure 11. A 450-ohm open-wire TV-type line may be used to feed the horn.

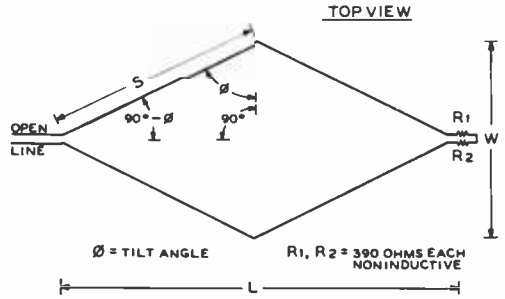

Figure 13

VHF RHOMBIC ANTENNA CONSTRUCTION

23-7 VHF Horizontal Rhombic Antenna

For vhf transmission and reception in a fixed direction, a horizontal rhombic permits 10 to 16 db gain with a simpler construction than does a phased dipole array, and has the further advantage of being useful over a wide frequency range.

Except at the upper end of the vhf range a rhombic array having a worthwhile gain is too large to be rotated. However, in locations 75 to 150 miles from a large metropolitan area a rhombic array is ideally suited for working into the city on extended (horizontally polarized) ground wave while at the same time making an ideal antenna for TV reception.

The useful frequency range of a vhf rhombic array is about 2 to 1, or about plus

40% and minus 30% from the design frequency. This coverage is somewhat less than that of a high-frequency rhombic used for sky-wave communication. For ground-wave transmission or reception the only effective vertical angle is that of the horizon, and a frequency range greater than 2 to 1 cannot be covered with a rhombic array without an excessive change in the vertical angle of maximum radiation or response.

The dimensions of a vhf rhombic array are determined from the design frequency and figure 12, which shows the proper tilt angle (see figure 13) for a given leg length. The gain of a rhombic array increases with leg length. There is not much point in constructing a vhf rhombic array with legs shorter than about 4 wavelengths, and the beam width begins to become excessively sharp for leg lengths greater than about 8 wavelengths. A leg length of 6 wavelengths is a good compromise between beam width and gain.

The tilt angle given in figure 12 is based on a wave angle of zero degrees. For leg

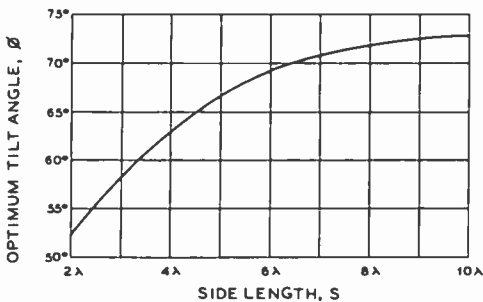

Figure 12

VHF RHOMBIC ANTENNA DESIGN CHART

The optimum tilt angle (see figure 13) for "zero-angle" radiation depends on the length of the sides.

	6 METERS AND LOW-BAND TV	2 METERS, HIGH-BAND TV, AND 1 1/2 METERS
S (side)	90'	32'
L (length)	166' 10"	59' 4"
W (width)	67' 4"	23' 11"
S = 6 wavelengths at design frequency Tilt angle = 68°		

TABLE 3.

DIMENSIONS FOR TWO DUAL-PURPOSE RHOMBIC ARRAYS

lengths of 4 wavelengths or longer, it will be necessary to elongate the array a few percent (pulling in the sides slightly) if the horizon elevation exceeds about 3 degrees.

Table 3 gives dimensions for two dual purpose rhombic arrays. One covers the 6-meter amateur band and the "low" television band. The other covers the 2-meter amateur band, the "high" television band, and the 1¼-meter amateur band. The gain is approximately 12 db over a matched half wave dipole and the beam width is about 6 degrees.

The Feed Line The recommended feed line is an open-wire line having a surge impedance between 450 and 600 ohms. With such a line the SWR will be less than 2 to 1. A line with two-inch spacing is suitable for frequencies below 100 MHz, but one-inch spacing is recommended for higher frequencies.

The Termination If the array is to be used only for reception, a suitable termination consists of two 390-ohm carbon resistors in series. If 2-watt resistors are employed, this termination also is suitable for transmitter outputs of 10 watts or less. For higher powers, however, resistors having greater dissipation with negligible reactance in the upper vhf range are not readily available.

For powers up to several hundred watts a suitable termination consists of a "lossy" line consisting of stainless-steel wire (corresponding to No. 24 or 26 gauge) spaced 2 inches, which in turn is terminated by two 390-ohm 2-watt carbon resistors. The dissipative line should be at least 6 wavelengths long.

23-8 The Log-Periodic Antenna

Frequency-independent antennas, of which the *Log-periodic* array is an example, are structures that have the same performance at different frequencies by virtue of the fact that the array is self-scaling and has no dimensions that are frequency sensitive. A basic self-scaling structure (shown

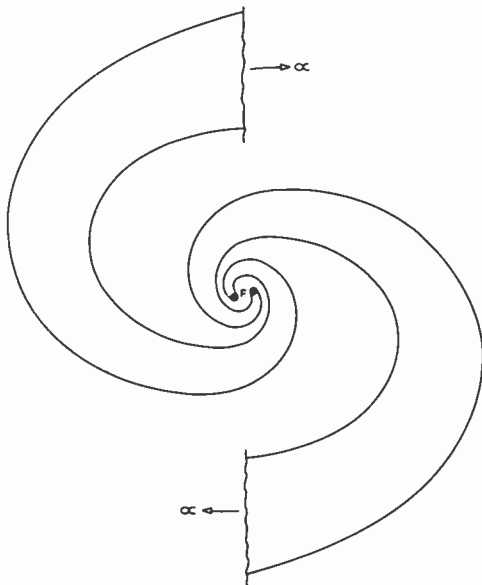

Figure 14

SPIRAL ANTENNA STRUCTURE

This equiangular spiral antenna structure serves as a frequency independent antenna as its shape is entirely specified by angles. The shape of the antenna, when expressed in terms of operating wavelength, is the same for any frequency. The structure is fed at the center (point F) and the arm length is infinite.

in figure 14) is described by angles alone, with no characteristic length. Practical structures of this type are finite in size, thus limiting the frequency-independent behavior. Variations of this basic design may take the form of toothed structures, such as illustrated.

An outgrowth of this form of wideband antenna is the *log-periodic dipole array* (figure 15) which is well suited to vhf and uhf work. This interesting antenna is made up of dipole elements whose lengths are determined by the angle they subtend from the apex point, and whose distance from the apex is such as to provide the log-periodic behavior. The dipoles are fed at the center from a parallel-wire line in such fashion that successive dipoles come out from the line in opposite directions, equivalent to a 180° phase shift between elements. A broad-band log-periodic structure is thus formed, with most of the radiation coming from

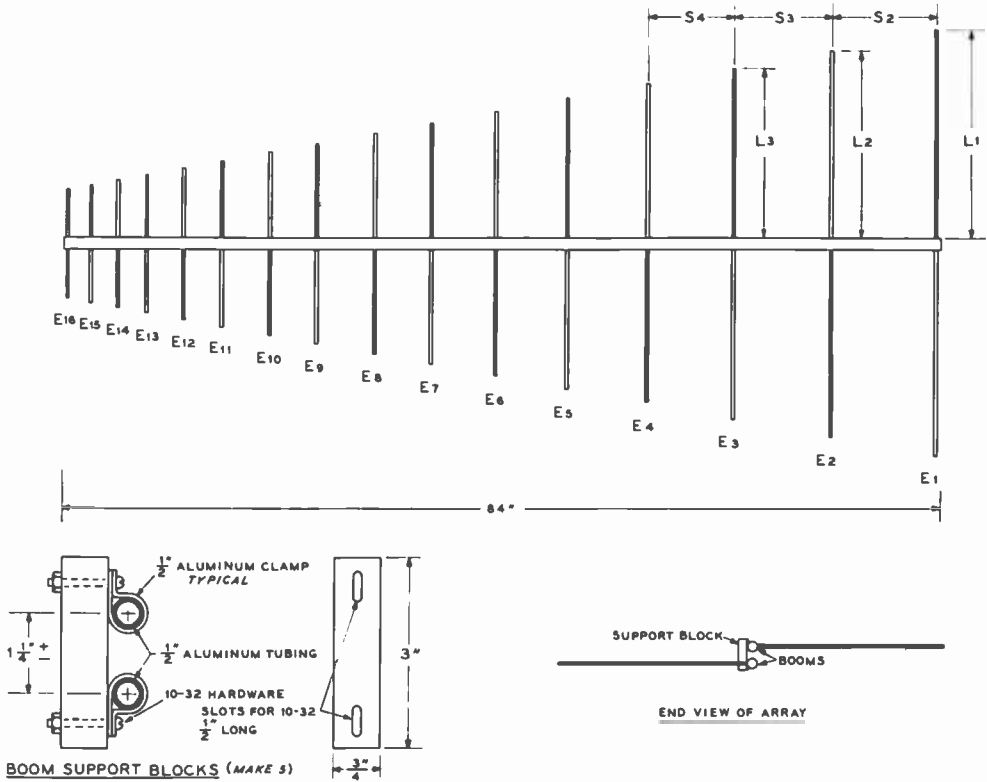

L-P YAGI DIMENSIONS

ELEMENT (L)	1	2	3	4	5	6	7	8	9	10	11	12	13	14	15	16
LENGTH	19½	17½	16½	15	13	11¾	10¾	9¾	8¾	8	7¼	6½	6	5¾	4¾	4½
SPACING (S)	—	10	9½	8½	7¾	6¾	6¼	5½	5½	4½	4½	3¾	3½	2¾	2½	2

Figure 15

LOG-PERIODIC ANTENNA FOR 140 TO 450 MHz

Vhf log-periodic dipole array is built on double-boom structure made of two lengths of aluminum tubing spaced by insulated support blocks. Elements coded black are attached to the top boom and elements coded white are attached to the lower boom. The coaxial transmission line is inserted in the rear of one boom and passed through the boom, which acts as a balancing device. Center conductor is attached to opposite boom, and shield is attached to balancing boom.

those dipole elements in the vicinity of a half-wavelength long. The bandwidth of the structure is thus limited by the length of the longest and shortest elements, which must be approximately a half-wavelength long at the extreme frequency limits of the antenna array. Gain and bandwidth of the log-periodic antenna thus bear a definite

relationship to the included angle of the structure and the length.

An easily constructed log-periodic antenna is the *log-periodic dipole array*, a two-dimensional structure made up of a series of dipoles, fed at the center in such a way that adjacent dipoles are out of phase. The array is fed at the apex and the elements

are excited from a parallel-wire transmission line which, if properly designed, may serve as the support structure for the dipoles. The dipole array, in effect, is a balanced transmission line with elements fed from each line, each set of elements reversed in feed polarity. The limiting structure, is a two-element array, and amateur versions of this device are often termed the "ZL-Special" antenna.

The balanced log-periodic dipole structure may be fed with an unbalanced coaxial line by using the support structure as a balun, feeding the coaxial line back from the feed-point through the structure toward the rear.

A L-P Dipole Array for 140–450 MHz A practical L-P dipole array for the vhf spectrum is shown in figure

15. The antenna has a power gain over a dipole of about 7 decibels and may be fed with a 50-ohm coaxial transmission line. The maximum SWR on the transmission line, after adjustment of the boom spacing is better than 2.5/1 over the entire range. The L-P array is built on a twin boom made of 1/2-inch diameter, heavy-wall aluminum tubing. Two lengths of material are clamped together to form a low-impedance transmission line 86" long. The clamps may be made of hard wood, or other good insulating material. An impedance match between the array and the transmission line is effected by varying the spacing of the boom, which changes the impedance of the transmission line created by the proximity of the booms to each other.

Alternate halves of successive dipole elements are fastened to a boom section by threading the element, and affixing it to a clamp, as shown in the illustration. Element spacings are measured from the rear of the array and are rounded off to the nearest quarter inch.

When the array is completed, all elements lie in the same plane, with successive elements off center from the supporting structure by virtue of the alternate feed system employed. Boom spacing should be set as shown in the drawing, and later adjusted for minimum SWR on the coaxial transmission line at the various frequencies of interest.

The coaxial line is passed through one boom from the rear and connection to both booms is made at the nose of the array. The outer braid of the line is connected to the boom through which the line passes, and the center conductor connects to the opposite boom. Type-N coaxial connectors are recommended for use in this frequency region.

A L-P Yagi for 50 MHz A yagi antenna consists of a driven element plus parasitic elements to increase the gain and directivity of the radiation pattern over that of a dipole. The number of parasitic elements, their length and spacing with respect to the driven element determine the characteristics of the parasitic yagi antenna. As gain and directivity increase, bandwidth decreases, limiting the ultimate usefulness of this antenna over a complete amateur band, especially at 10 meters and above. To increase the bandwidth of the array, the log-periodic principle used for broadband antennas may be applied to the parasitic beam. The log-periodic yagi array consists of log-periodic elements, interspersed with parasitic reflectors and directors to form individual cells, differing in size by a geometric constant. The driven element in each cell is fed by a common balanced transmission line.

A variation of the log-periodic principle is used in the parasitic antenna described in this section. This L-P yagi antenna is composed of a five element log-periodic section designed to cover the 50- to 52-MHz range and is used in conjunction with three parasitic director elements mounted in front of the log-periodic section. A top view of the antenna is shown in figure 16. The antenna exhibits about 12 decibels forward gain and compares nearly identically with an 8-element yagi mounted on a 30-foot boom. The over-all length of the L-P yagi is only about 18½ feet and it provides improved bandwidth performance and smaller size than the comparable yagi array.

This antenna configuration was designed and developed by the Swan Antenna Co., 646 No. Union St., Stockton, Calif. and is manufactured by that company for amateur and television use. Thanks is given to Mr. Oliver Swan for permission to publish this description of this unusual antenna.

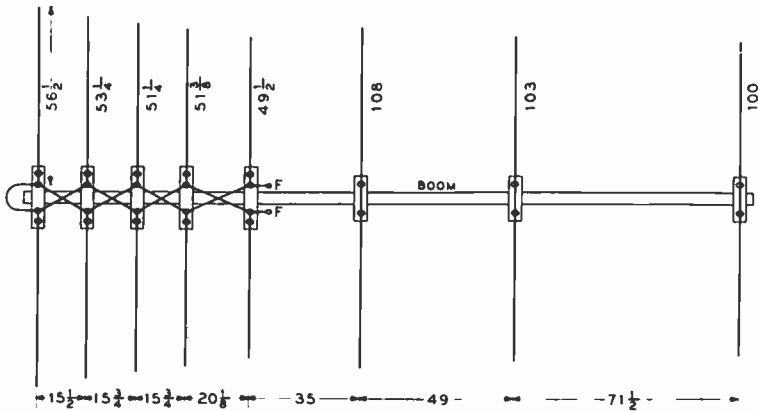

Figure 16

L-P YAGI ANTENNA FOR SIX METERS

This design combines bandwidth of log-periodic structure with gain of yagi antenna. L-P yagi may be built on 1 1/2-inch diameter boom, about 19 feet long. L-P elements are insulated from boom by mounting on insulating blocks. Yagi elements are grounded to boom at their center point. The antenna is fed with a balanced 70-ohm ribbon line at the feedpoint and the L-P transmission line is made up of No. 8 aluminum clothesline wire, criss-cross connected between the elements. Rear element is shorted with six-inch loop of aluminum wire. The spacing between the inner tips of the L-P elements is 3 1/2 inches.

23-9 VHF Yagi Beam Antennas

The multielement rotary beam is undoubtedly the most popular type of vhf antenna in use. In general, the design, assembly and tuning of these antennas follows a pattern similar to that used for the larger rotary arrays used on the lower-frequency amateur bands. The characteristics of the latter antennas are discussed in the next chapter of this Handbook, and the information contained in that chapter applies in general to the vhf beam antennas discussed herewith.

Element Lengths Optimum length for parasitic elements in vhf arrays is a function of element spacing and the diameter of the element. To hold a satisfactory length/diameter ratio, the diameter of the element must decrease as the frequency of operation is raised. At very-high frequencies, element length is so short that the diameter of a self-supporting element becomes a large fraction of the length.

Short, large-diameter elements have low Q and are not practical in parasitic arrays. Thus the yagi array becomes critical in adjustment and marginal in operation in the upper reaches of the vhf spectrum. Yagi antennas can be made to work at 432 MHz and higher, but their adjustment is tedious, and preference is given to broadside arrays having relatively large spacings between elements and high impedance. The yagi antenna, however, remains "the antenna to beat" for the 50-, 144-, and 220-MHz amateur bands.

The yagi antennas shown in this section are of all-metal construction with the elements directly grounded to the boom. Either a gamma-match system, T match, or folded-dipole element may be used on the arrays. For short lengths of transmission line, 50-ohm low-loss coaxial cable is recommended for use with a gamma match, or with folded dipole or T match and a coaxial balun. Longer line lengths should be made up of 300-ohm TV-type "ribbon" line or open-wire TV-type transmission line. Care should be taken to keep the ribbon or open-wire lines clear of nearby metallic objects.

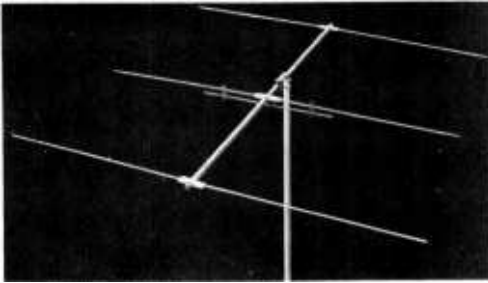

Figure 17

THREE-ELEMENT YAGI BEAM FOR SIX METERS

This all-aluminum array is a popular six-meter antenna. Available in kit form (Hy-Gain), it also may easily be constructed from available aluminum tubing. Elements are clamped to the boom and either a T match, Gamma match, or split-driven-element feed system used. T match with half-wave coaxial balun is recommended system for ease in adjustment. Brass or aluminum hardware should be employed to prevent corrosion of elements due to weather.

Yagi Beams All-aluminum beam antennas for 6 and 2 are easy to construct for the 6- and 2-meter amateur bands. The three-element array is very popular for general 6-meter operation, and up to ten elements are often used for DX work on this band. The four-element array is often used on 2 meters, either horizontally or vertically polarized, and arrays having as many as twelve to fifteen elements are used for meteor-scatter and over-horizon work on 144 MHz.

Shown in figures 17 and 18 is a simple three-element array for the 6-meter band. The design frequency is 50.5 MHz, and the beam is capable of operation over the 50- to 51-MHz frequency span. The antenna may be fed from a 50-ohm coaxial line with a half-wave balun and T match as shown in the illustration. The supporting boom is made of a length of 1/8-inch diameter aluminum TV mast section, and the elements are made of 1/2-inch diameter aluminum tubing. The elements are mounted in position by drilling the boom to pass the element and then clamping the joint as shown in the drawing.

The T-match system must be properly resonated at the center frequency of antenna operation. To do this, the antenna is tem-

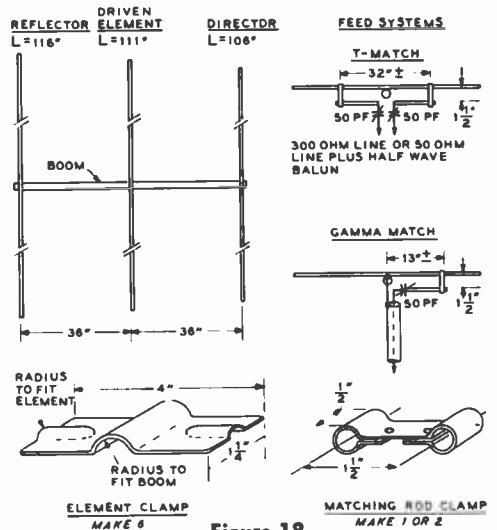

Figure 18

SIX-METER BEAM ASSEMBLY

Element clamps are fabricated from soft aluminum strip. All joints should be cleaned and covered with Penetrox paste to prevent corrosion. Elements may be made of sections of telescoping tubing. Diameters between one inch and one-half inch are recommended.

porarily mounted atop a step ladder, in the clear, and fed with a few watts of power from the station transmitter. An SWR meter or reflectometer is placed in the line near the antenna and the length of the T sections and the series capacitors are adjusted to provide the lowest value of SWR on the transmission line. The capacitors are varied in unison to preserve the symmetry of balance. The capacitors should be enclosed in a weatherproof box and mounted at the center of the T section.

A four-element array for the 2-meter band is shown in figures 19 and 20. Dimensions are given for a center frequency of 146 MHz. The antenna provides a power gain of about 9 decibels over a dipole and is capable of good operation over the complete 2-meter band. For optimum operation at the low end of the band, all element lengths should be increased by one-half inch.

Antenna construction is similar to the 6-meter array in that an aluminum section of tubing is used for the boom and the elements are passed through holes drilled in the boom. One-quarter inch aluminum tubing is used for the elements. The T match

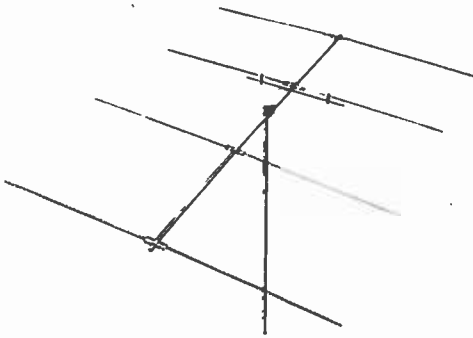

Figure 19

FOUR-ELEMENT YAGI BEAM FOR TWO METERS

Light aluminum is employed for easy-to-build two meter beam. Reynolds "Do It Yourself" aluminum, available at many hardware and building supply stores may be used. Construction is similar to six-meter array. If boom diameter is about one inch, the boom may be drilled for the elements, which are then held in place by a sheet-metal screw through boom and element.

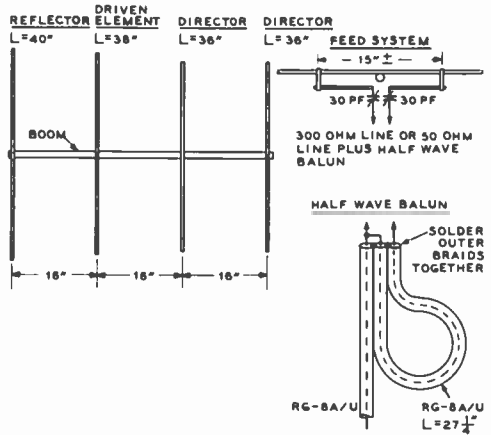

Figure 20

TWO-METER BEAM ASSEMBLY

and coaxial balun are used to match the antenna to a 50-ohm coaxial transmission line.

An 8-Element "Tiltable" Yagi for 144 MHz Two four-element beams may be stacked to double the power gain and to sharpen the pattern of a single beam.

Figure 21 illustrates an 8-element rotary beam for 144-MHz use. This array can be tilted to obtain either horizontal or vertical polarization. It is necessary that the transmitting and receiving stations use the same polarization for the ground-wave signal propagation which is characteristic of this frequency range. Although polarization has been loosely standardized in various areas of the country, exceptions are frequent enough so that it is desirable that the polarization of antenna radiation be easily changeable from horizontal to vertical.

The antenna illustrated has shown a signal gain of about 11 db, representing a power gain of about 13. Although the signal gain of the antenna is the same whether it is oriented for vertical or horizontal polarization, the horizontal beam width is smaller when the antenna is oriented for vertical

polarization. Conversely, the vertical pattern is sharper when the antenna system is oriented for horizontal polarization.

The changeover from one polarization to the other is accomplished simply by pulling on the appropriate cord. Hence, the operation is based on the offset head sketched in figure 21. Although a wood mast has been used, the same system may be used with a pipe mast.

The 40-inch lengths of RG-59/U cable (electrical $\frac{3}{4}$ -wavelength) running from the center of each folded dipole driven element to the coaxial T-junction allow enough slack to permit free movement of the main boom when changing polarity. Type RG-8/U cable is run from the T-junction to the operating position. Measured standing-wave ratio was less than 2:1 over the 144- to 148-MHz band, with the lengths and spacing given in figure 21.

Construction of the Array Most of the constructional aspects of the antenna array are self-evident from figure 21. However, the pointers given in the following paragraphs will be of assistance to those wishing to reproduce the array.

The drilling of holes for the small elements should be done carefully on accurately marked centers. A small angular error in the drilling of these holes will result in a

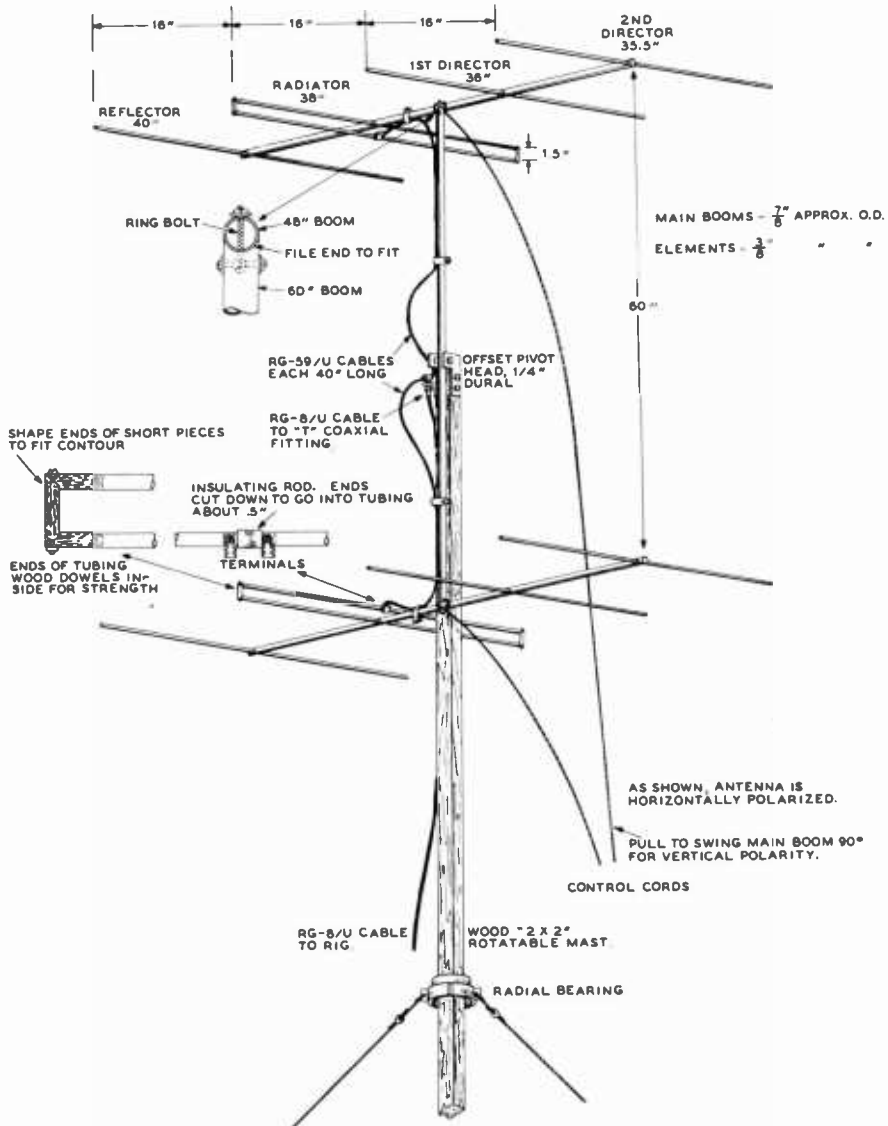

Figure 21
CONSTRUCTION DRAWING OF AN EIGHT-ELEMENT TILTABLE 144-MHz ARRAY

considerable misalignment of the elements after the array is assembled. The same consideration is true of the filing out of the rounded notches in the ends of the main boom for the fitting of the two-antenna booms.

Short lengths of wood dowel are used freely in the construction of the array. The

ends of the small elements are plugged with an inch or so of dowel, and the ends of the antenna booms are similarly treated with larger discs pressed into place.

The ends of the folded dipoles are made in the following manner: Drive a length of dowel into the short connecting lengths of aluminum tubing. Then drill down the cen-

ter of the dowel with a clearance hole for the connecting screw. Then shape the ends of the connecting pieces to fit the sides of the element ends. After assembly the junctions may be dressed with a file and sandpaper until a smooth fit is obtained.

The mast used for supporting the array is a 30-foot spliced 2 by 2. A large discarded ball bearing is used as the radial load bearing and guy-wire termination. Enough of the upper-mast corners were removed with a drawknife to permit sliding the ball bearing down about 9 feet from the top of the mast. The bearing then was encircled by an assembly of three pieces of dural ribbon to form a clamp, with ears for tightening screws and attachment of the guy wires. The bearing then was greased and covered with a piece of auto inner tube to serve as protection from the weather. Another junk-box bearing was used at the bottom of the mast as a thrust bearing.

The main booms were made from 3/4-inch aluminum electrical conduit. Any size of small tubing will serve for making the elements. Note that the main boom is mounted at the balance center and not necessarily at the physical center.

In connecting the phasing sections between the T-junction and the centers of the folded dipoles, it is important that the center conductors of the phasing sections be connected to the same side of the driven elements of the antennas. In other words, when the antenna is oriented for horizontal polarization and the center of the coaxial section goes to the left side of the top antenna, the center conductor of the other coaxial phasing section should go to the left side of the bottom antenna.

Long Yagi Antennas For a given power gain, the Yagi antenna can be built lighter, more compact, and with less

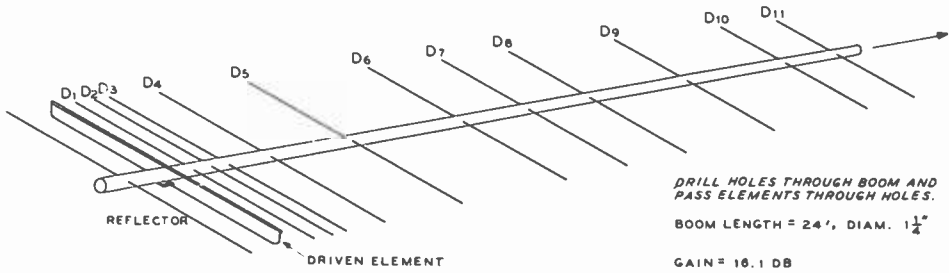

ELEMENT DIMENSIONS, 2-METER BAND

ELEMENT (DIAM. 1/8")	LENGTH				SPACING FROM DIPOLE
	144 MHz	145 MHz	146 MHz	147 MHz	
REFLECTOR	41"	40 3/4"	40 7/16"	40 3/16"	19"
DIRECTORS	36 3/4"	36 1/2"	36 3/8"	36 3/16"	

DRIVEN ELEMENT	
38.5"	CLEARANCE HOLE FOR BOLT
BOOM	INSULATING PLATE
1" 3/4"	FLATTEN TUBING AT ENDS.
# 6 WIRE FOR 300 Ω MATCH. # 10 WIRE FOR 450 Ω MATCH.	

D1 = 7"
D2 = 14.5"
D3 = 22"
D4 = 36"
D5 = 70"
D6 = 102"
D7 = 134"
D8 = 166"
D9 = 198"
D10 = 230"
D11 = 242"

Figure 22

DESIGN DIMENSIONS FOR A 2-METER LONG YAGI ANTENNA

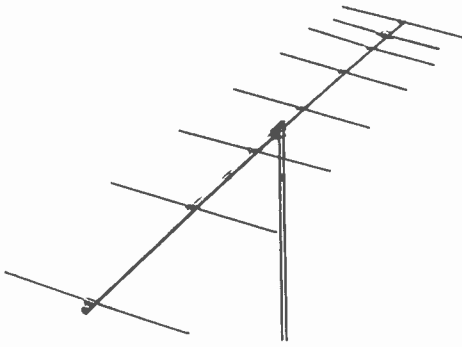

Figure 23

TWO-METER LONG YAGI ARRAY

Elements are mounted atop boom by means of small clamps made of soft aluminum strap. Either folded dipole or T-matching device may be used with antenna. Eight-element beam similar in construction is manufactured by Hy-Gain and sold in kit form.

wind resistance than any other type. On the other hand, if a Yagi array of the same approximate size and weight as another antenna type is built, it will provide a higher order of power gain and directivity than that of the other antenna.

The power gain of a Yagi antenna increases directly with the physical length of the array. The maximum practical length is entirely a mechanical problem of physically supporting the long series of director elements, although when the array exceeds a few wavelengths in length the element lengths, spacings, and Q's becomes more and more critical. The effectiveness of the array depends on a proper combination of the mutual coupling loops between adjacent directors and between the first director and the driven element.

Practically all work on Yagi antennas with more than three or four elements has

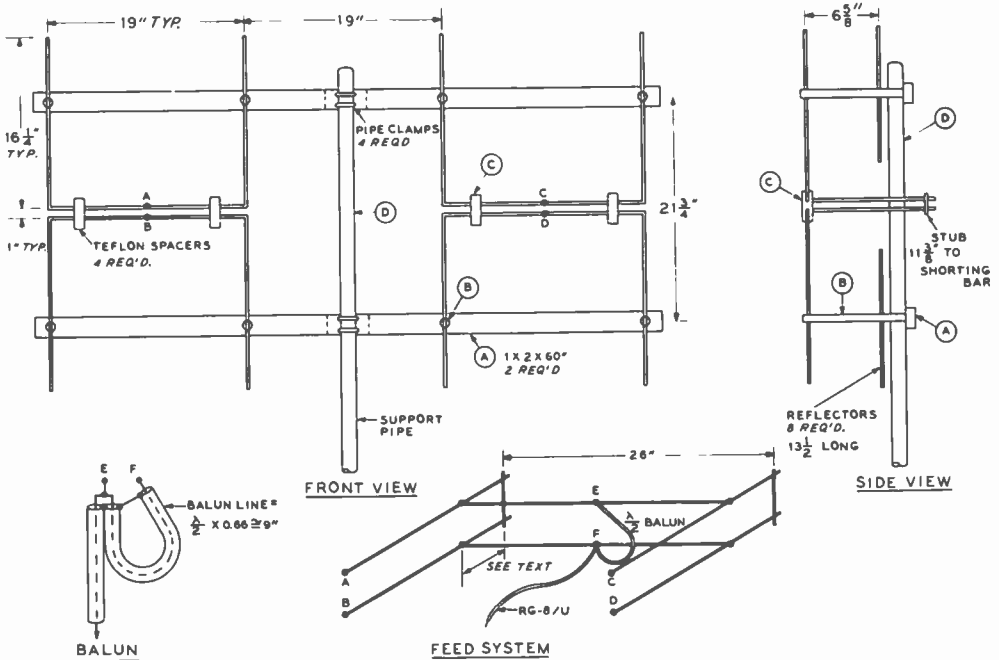

Figure 24

W6GD EXPANDED BROADSIDE ARRAY FOR TWO METERS

The 16-element beam is made of brass rod suspended from a wooden frame at low-voltage points on the antenna. Small ceramic insulators are used to mount the rods. Antenna elements and lines are aligned by means of small teflon or polystyrene spacer blocks passed over the rods before they are bent into shape. Half-wave lines are employed in feed system, together with a full-wavelength transformer and balun to provide a close match to a 50-ohm transmission line. Lines and transformer are made up of brass rod and adjustable shorting bars are used.

been on an experimental, cut-and-try basis. Figure 22 provides dimensions for a typical long Yagi antenna for the 2-meter vhf band. Note that all directors have the same physical length. If the long Yagi is designed so that the directors gradually decrease in length as they progress from the dipole bandwidth will be increased, and both side lobes and forward gain will be reduced. One advantage gained from staggered director length is that the array can be shortened and lengthened by adding or taking away directors without the need for re-tuning the remaining group of parasitic elements. When all directors are the same length, they must be all shortened *en masse* as the array is lengthened, and vice versa when the array is shortened.

The W6GD Broadside Array for 432 MHz The extended-expanded broadside array was designed by the late W6GD of Stanford University and has consistently out-performed larger and more sophisticated antennas at 432 MHz. The W6GD beam is a 16-element beam and has been measured to have 12 decibels power gain over a dipole. Extended elements are used with $\frac{3}{4}$ -wavelength spacing. The array

has a sharp front lobe, with nulls at 19° and 42° each side of center and must be aimed carefully for best results.

All elements are made of 0.175-inch diameter brass rod. The active elements are made of square "U"s bent from four lengths of rod, each $5\frac{1}{2}$ inches long. The half-wavelength reflectors are cut of the same material and are $13\frac{3}{8}$ -inches long. The W6GD array is built on a wooden framework, so designed as to keep the supporting structure in back of the array. The driven elements are self-supporting except for four insulating blocks placed at low-voltage points. The blocks and spacers are drilled and slipped on the brass rods before the assembly is bent into shape (figure 24).

After assembly, the matching stubs are silver-soldered to the driven elements and the balun and the interconnecting transmission line temporarily connected in place. The line is tapped up each stub to attain a low value of SWR on the coaxial or open-wire transmission line. Placement of the taps is determined by experiment.

A complete discussion of vhf antennas is contained in the *VHF Handbook*, available from Radio Publications, Inc., Wilton, Conn.

High-Frequency Rotary-Beam Antennas

The rotatable antenna array has become almost standard equipment for operation on the 28- and 50-MHz bands and is commonly used on the 14- and 21-MHz bands and on those frequencies above 144 MHz. The rotatable array offers many advantages for both military and amateur use. The directivity of the antenna types commonly employed (particularly the unidirectional arrays) offers a worthwhile reduction in interference from undesired directions. Also, the increase in the ratio of low-angle radiation plus the theoretical gain of such arrays results in a relatively large increase in both the transmitted signal and the signal intensity from a station being received.

There are two normal configurations of radiating elements which, when horizontally polarized, will contribute to obtaining a low angle of radiation. These configurations are the end-fire array and the broadside array. The conventional three- or four-element rotary beam may properly be called a *unidirectional parasitic end-fire array*, and is actually a type of *yagi* array. The flat-top beam is a type of *bidirectional end-fire array*. The *broadside type* of array is also quite effective in obtaining low-angle radiation, and, although widely used in f-m and TV broadcasting, has seen little use by amateurs in rotatable arrays because of its size.

24-1 Unidirectional Parasitic End-Fire Arrays (Yagi Type)

If a single parasitic element is placed on one side of a driven dipole at a distance of from 0.1 to 0.25 wavelength the parasitic element can be tuned to make the array substantially unidirectional.

This simple array is termed a *two-element parasitic beam*.

The Two-Element Beam The two-element parasitic beam provides the greatest amount of gain per unit size of any array commonly used by radio amateurs. Such an antenna is capable of a signal gain of 5 db over a dipole, with a front-to-back ratio of 7 to 15 db, depending on the adjustment of the parasitic element. The parasitic element may be used either as a director or as a reflector.

The optimum spacing for a reflector in a two-element array is approximately 0.13 wavelength and with optimum adjustment of the length of the reflector a gain of approximately 5 db will be obtained, with a feed-point resistance of about 25 ohms.

If the parasitic element is to be used as a director, the optimum spacing between it

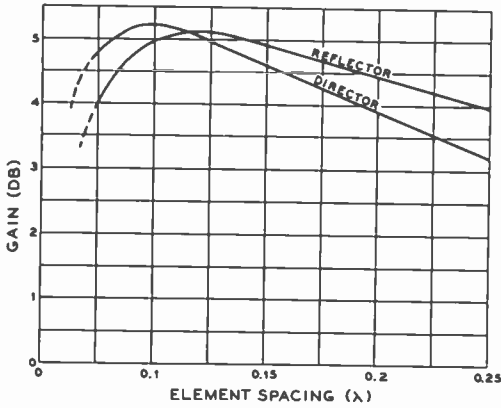

Figure 1

GAIN VERSUS ELEMENT SPACING FOR A TWO-ELEMENT CLOSE-SPACED PARASITIC BEAM ANTENNA WITH PARASITIC ELEMENT OPERATING AS A DIRECTOR OR REFLECTOR

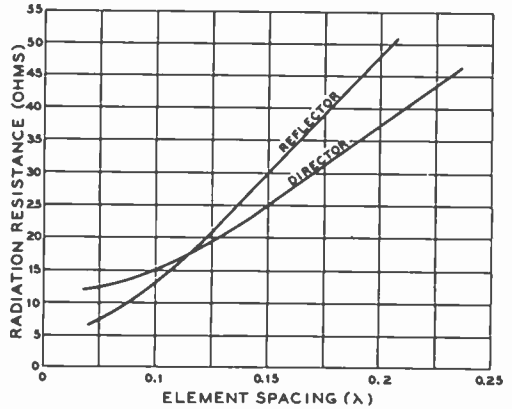

Figure 2

RADIATION RESISTANCE AS A FUNCTION OF THE ELEMENT SPACING FOR A TWO-ELEMENT PARASITIC ARRAY

and the driven element is 0.11 wavelength.

The general characteristics of a two-element parasitic array may be seen in figures 1, 2 and 3. The gain characteristics of a two-element array when the parasitic element is used as a director or as a reflector are shown. It can be seen that the director provides a maximum of 5.3 db gain at a spacing of slightly greater than 0.1 wavelength from the antenna. In the interests of greatest power gain and size conservation, therefore, the choice of a parasitic director would be wiser than the choice of a parasitic reflector, although the gain difference between the two is small.

Figure 2 shows the relationship between the element spacing and the radiation resistance for the two-element parasitic array for both the reflector and the director case. For either type of array, the radiation resistance falls in the 15- to 25-ohm region for typical spacings.

Figure 3 shows the front-to-back ratio for the two-element parasitic array for both the reflector and director cases. To produce these curves, the elements were tuned for maximum gain of the array. Better front-to-back ratios may be obtained at the expense of array gain, if desired, but the general shape of the curves remains the same.

It can be readily observed that operation of the parasitic element as a reflector produces relatively poor front-to-back ratios except when the element spacing is greater than 0.15 wavelength. However, at this element spacing, the gain of the array begins to suffer.

Since a radiation resistance of 17 ohms is not unduly hard to match, it can be argued that the best all-around performance may be obtained from a two-element parasitic beam employing 0.11 element spacing, with the parasitic element tuned to operate as a director. This antenna will provide a for-

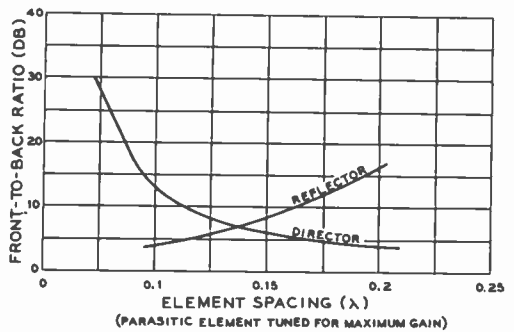

Figure 3

FRONT-TO-BACK RATIO AS A FUNCTION OF ELEMENT SPACING FOR A TWO-ELEMENT PARASITIC ARRAY

ward gain of 5.3 db, with a front-to-back ratio of 10 db, or slightly greater. Closer spacing than 0.11 wavelength may be employed for greater front-to-back ratios, but the radiation resistance of the array becomes quite low, the bandwidth of the array becomes very narrow, and the tuning becomes quite critical. Thus the Q of the antenna system will be *increased* as the spacing between the elements is *decreased*, and smaller optimum frequency coverage will result.

Element Lengths When the parasitic element of a two-element array is used as a director, the following formulas may be used to determine the lengths of the driven element and the parasitic director, assuming an element diameter-to-length ratio of 200 to 400:

$$\text{Driven element length (feet)} = \frac{476}{F_{\text{MHz}}}$$

$$\text{Director length (feet)} = \frac{450}{F_{\text{MHz}}}$$

$$\text{Element spacing (feet)} = \frac{120}{F_{\text{MHz}}}$$

The effective bandwidth taken between the 1.5/1 standing-wave points of an array cut to the above dimensions is about 2.5 percent of the operating frequency. This means that an array precut to a frequency of 14,150 kHz would have a bandwidth of 350 kHz (plus or minus 175 kHz of the center frequency), and therefore would be effective over the whole 20-meter band. In like fashion, a 15-meter array should be precut to 21,200 kHz.

A beam designed for use on the 10-meter band would have an effective bandwidth of some 700 kHz. Since the 10-meter band is 1700 kHz in width, the array should either be cut to 28,500 kHz for operation in the low-frequency portion of the band, or to 29,200 kHz for operation in the high-frequency portion of the band. Operation of the antenna outside the effective bandwidth will increase the SWR on the transmission line, and noticeably degrade both the gain and front-to-back ratio performance. The height above ground also influences the F/B ratio.

24-2 The Three-Element Array

The three-element array using a director, driven element, and reflector will exhibit as much as 30 db front-to-back ratio and 20 db front-to-side ratio for *low-angle radiation*. The theoretical gain is about 9 db over a dipole in free space. In actual practice, the array will often show 7 to 8 db apparent gain over a horizontal dipole placed the same height above ground (at 28 and 14 MHz).

The use of more than three elements is desirable when the length of the supporting structure is such that spacings of approximately 0.15 wavelength between elements becomes possible. Four-element arrays are quite common on the 28- and 50-MHz bands, and five elements are sometimes used for increased gain and discrimination. As the number of elements is increased the gain and front-to-back ratio increases but the bandwidth or frequency range over which the antenna will operate without reduction in effectiveness is decreased.

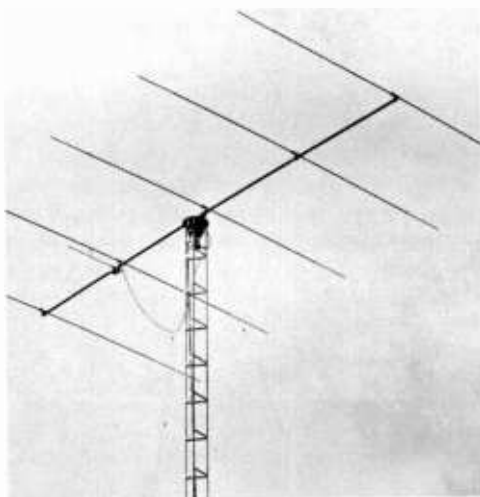

Figure 4

FIVE ELEMENT 28-MHz BEAM ANTENNA AT W6SAI

Antenna boom is made of twenty foot length of three-inch aluminum irrigation pipe. Spacing between elements is five feet. Elements are made of twelve foot lengths of 7/8-inch aluminum tubing, with extension tips made of 3/4-inch tubing. Beam dimensions are taken from figure 5.

Material for Elements The majority of high-frequency beams make use of elements composed of telescoping sections of metal tubing. This configuration is easy to construct and avoids the problem of getting sufficiently good insulation at the ends of the elements. The voltages reach such high values toward the ends of the elements that losses will be excessive, unless the insulation is excellent.

The elements may be fabricated of thin-walled steel conduit, or hard-drawn thin-walled copper tubing, but *dural* tubing is much better. Dural tubing may be obtained in telescoping sizes from large metal-supply houses in many cities. Various manufacturers, moreover, supply beam antenna kits of all types and prices. The majority of these beams employ dural elements because of the good weather-capability of this material.

Element Spacing The optimum spacing for a two-element array is, as has been mentioned before, approximately 0.11 wavelength for a director and 0.13 wavelength for a reflector. However, when both a director and a reflector are combined with the driven element to make up a three-element array the optimum spacing is established by the bandwidth which the antenna will be required to cover. Wide spacing (of the order of 0.25 wavelength between elements) will result in greater bandwidth for a specified maximum standing-wave ratio on the antenna transmission line. Smaller spacings may be used when boom length is an important consideration, but for a specified standing-wave ratio and forward gain the frequency coverage will be smaller. Thus the *Q* of the antenna system will be *increased* as the spacing between the elements is *decreased*, resulting in smaller frequency coverage, and at the same time the feed-point impedance of the driven element will be decreased.

For broad band coverage, such as the range from 28.0 to 29.7 MHz or from 50 to 54 MHz, 0.2 wavelength spacing from the driven element to each of the parasitic elements is recommended. For narrower bandwidth, such as would be adequate for the 14.0- to 14.4-MHz band or the 21-

21.45 MHz band, the radiator-to-parasitic element spacing may be reduced to 0.12 wavelength, while still maintaining adequate array bandwidth for the amateur band in question.

Length of the Parasitic Elements Experience has shown that it is practical to cut the parasitic elements of a three-element parasitic array to a predetermined length before the installation of such an antenna. A pretuned antenna such as this will give good signal gain, adequate front-to-back ratio, and good bandwidth factor. By carefully tuning the array after it is in position the gain may be increased by a fraction of a db, and the front-to-back ratio by several db. However the slight improvement in performance is usually not worth the effort expended in tuning time.

The closer the lengths of the parasitic elements are to the resonant length of the driven element, the lower will be the feed-point resistance of the driven element, and the smaller will be the bandwidth of the array. Hence, for wide frequency coverage the director should be considerably shorter, and the reflector considerably longer than the driven element. For example, the director should still be less than a resonant half-wavelength at the upper frequency limit of the range wherein the antenna is to be operated, and the reflector should still be long enough to act as a reflector at the lower frequency limit. Another way of stating the same thing is to say, in the case of an array to cover a wide frequency range such as the amateur range from 28 to 29.7 MHz that the director should be cut for the upper end of the band and the reflector for the lower end of the band. In the case of the 28- to 29.7-MHz range this means that the director should be about 8 percent shorter than the driven element and the reflector should be about 8 percent longer. Such an antenna will show a relatively constant gain of about 6 db over its range of coverage, and the pattern will not reverse at any point in the range.

Where the frequency range to be covered is somewhat less, such as the 14.0- to 14.4-MHz amateur band, or the lower half of the amateur 28-MHz phone band, the re-

TYPE	DRIVEN ELEMENT LENGTH	REFLECTOR LENGTH	1ST DIRECTOR LENGTH	2ND DIRECTOR LENGTH	3RD DIRECTOR LENGTH	SPACING BETWEEN ELEMENTS	APPROX. GAIN DB	APPROX. RADIATION RESISTANCE (Ω)
3-ELEMENT	$\frac{473}{F}$ (MHz)	$\frac{501}{F}$ (MHz)	$\frac{445}{F}$ (MHz)	—	—	.15-.15	7.5	20
3-ELEMENT	$\frac{473}{F}$ (MHz)	$\frac{501}{F}$ (MHz)	$\frac{450}{F}$ (MHz)	—	—	.25-.25	6.5	35
4-ELEMENT	$\frac{473}{F}$ (MHz)	$\frac{501}{F}$ (MHz)	$\frac{450}{F}$ (MHz)	$\frac{450}{F}$ (MHz)	—	.2-.2-.2	9.5	20
5-ELEMENT	$\frac{473}{F}$ (MHz)	$\frac{501}{F}$ (MHz)	$\frac{450}{F}$ (MHz)	$\frac{450}{F}$ (MHz)	$\frac{450}{F}$ (MHz)	.2-.2-.2-.2	10.0	15

Figure 5

DESIGN CHART FOR PARASITIC ARRAYS (DIMENSIONS GIVEN IN FEET)

flector should be about 5 percent longer than the driven element, and the director about 5 percent shorter. Such an antenna will perform well over its rated frequency band, will not reverse its pattern over this band, and will show a signal gain of 7 to 8 db. See figure 5 for design figures for 3-element arrays.

More Than Three Elements A small amount of additional gain may be obtained through use of more than two parasitic elements, at the expense of reduced feed-point impedance and lessened bandwidth. One additional director will add about 1 db, and a second additional director (making a total of five elements including the driven element) will add slightly less than 1 db more. In the vhf range, where the additional elements may be added without much difficulty, and where required bandwidths are small, the use of more than two parasitic elements is quite practical.

Stacking of Yagi Arrays Parasitic arrays (yagis) may be stacked to provide additional gain in the same manner that dipoles may be stacked. Thus if an array of six dipoles would give a gain of 10 db, the substitution of yagi arrays for each of the dipoles would add the gain of *one* yagi array to the gain obtained with the dipoles. However, the yagi arrays *must be more widely spaced* than the dipoles to obtain this theoretical improvement. As an example, if six 5-element yagi arrays having a gain of about 10 db were substituted for the dipoles, with appropriate increase in the spacing between the arrays, the gain of the whole system would approach the sum of

the two gains, or 20 db. A group of arrays of yagi antennas, with recommended spacing and approximate gains, is illustrated in figure 6.

24-3 Feed Systems for Parasitic (Yagi) Arrays

The table of figure 5 gives, in addition to other information, the approximate radiation resistance referred to the center of the driven element of multielement parasitic arrays. It is obvious, from these low values of radiation resistance, that special care must be taken in materials used and in the construction of the elements of the array to ensure that ohmic losses in the conductors will not be an appreciable percentage of the radiation resistance. It is also obvious that some method of impedance transformation must be used in many cases to match the low radiation resistance of these antenna arrays to the normal range of characteristic impedance used for antenna transmission lines.

Impedance Matching A group of possible methods of impedance matching is shown in figures 7, 8, 9, and 10. All these methods have been used but certain of them offer advantages over some of the other methods. Generally speaking it is not mechanically desirable to break the center of the driven element of an array for feeding the system. Breaking the driven element rules out the practicability of building an all-metal type of array, and imposes mechanical limitations with any type of construction. However, when continuous rotation is desired, an arrangement such as

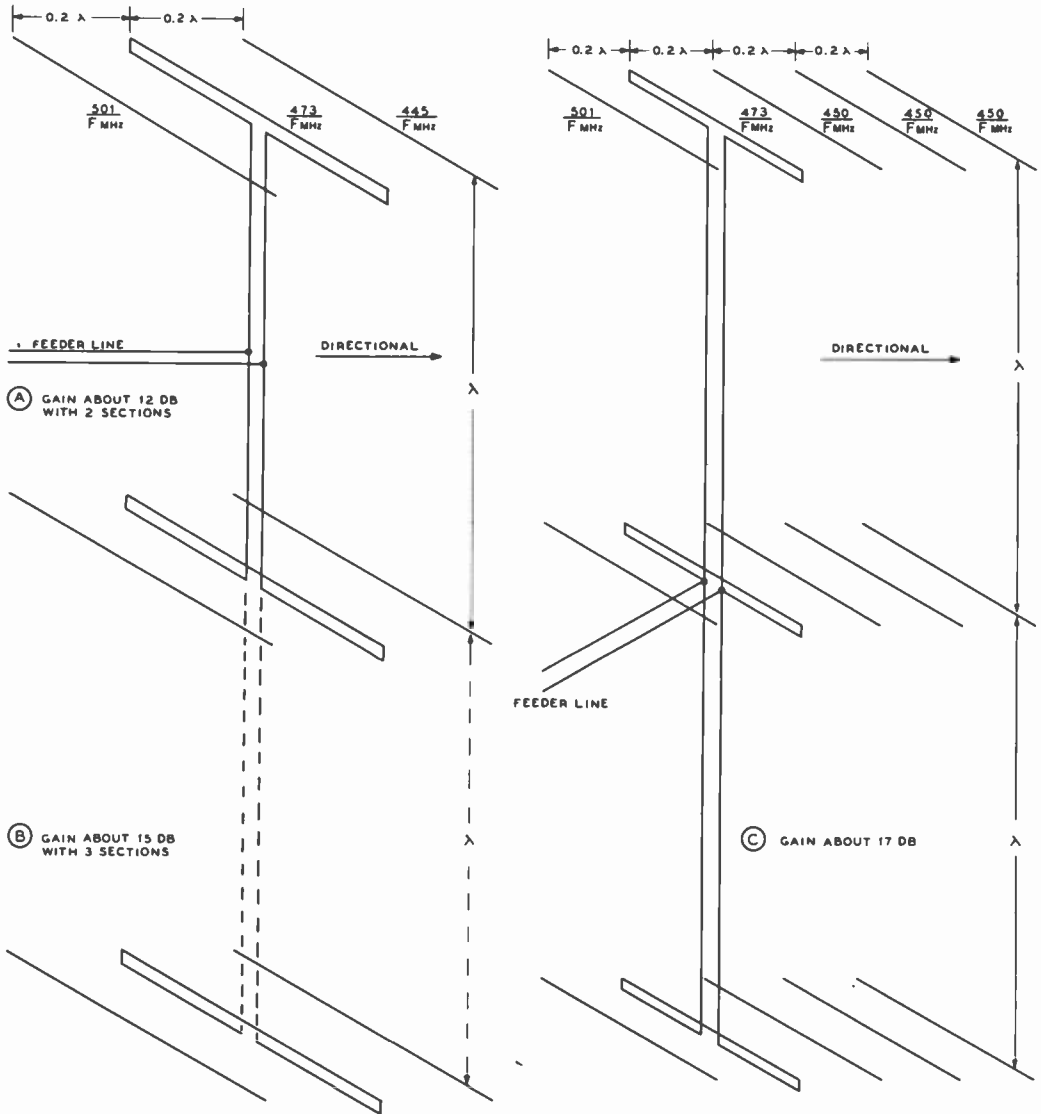

Figure 6

STACKED YAGI ARRAYS

It is possible to attain a relatively large amount of gain over a limited bandwidth with stacked yagi arrays. The two-section array at A will give a gain of about 12 db, while adding a third section will bring the gain up to about 15 db. Adding two additional parasitic directors to each section, as at C will bring the gain up to about 17 db.

shown in figure 9D utilizing a broken driven element with a rotatable transformer for coupling from the antenna transmission line to the driven element has proven to be quite satisfactory.

The feed systems shown in figure 7 will, under normal conditions, show the lowest losses of any type of feed system since the currents flowing in the matching network are the lowest of all the systems commonly

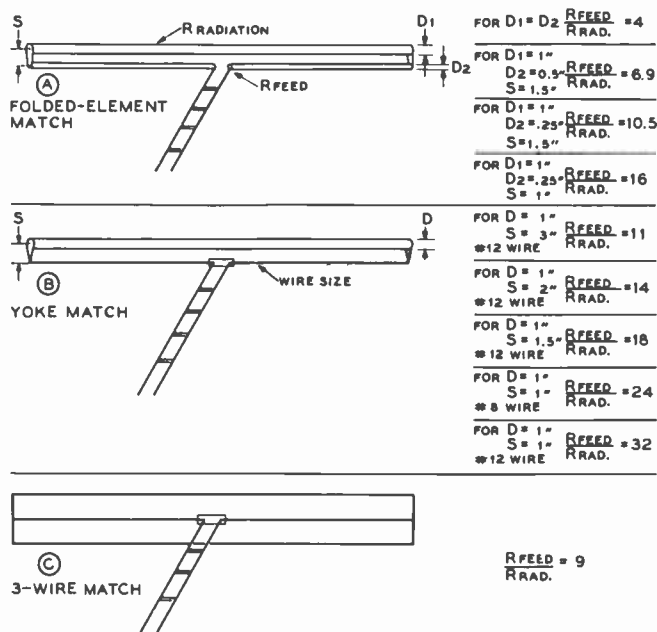

Figure 7

DATA FOR FOLDED-ELEMENT MATCHING SYSTEMS

In all normal applications of the data given the main element as shown is the driven element of a multielement parasitic array. Directors and reflectors have not been shown for the sake of clarity.

used. The *folded-element* match shown in figure 7A and the *Yoke* match shown in figure 7B are the most satisfactory, electrically, of all standard feed methods. However, both methods require the extension of an additional conductor out to the end of the driven element as a portion of the matching system. The folded-element match is best on the 50-MHz band and higher where the additional section of tubing may be supported below the main radiator element without undue difficulty. The yoke-match is more satisfactory mechanically on the 28- and 14-MHz bands since it is only necessary to suspend a wire below the driven element proper. The wire may be spaced below the self-supporting element by means of several small strips of polystyrene which have been drilled for both the main element and the small wire and threaded on the main element.

The Folded-Element Match Calculations The calculation of the operating conditions of the folded-element matching systems and the yoke match, as shown in figures 7A and 7B is relatively simple. A selected group of operating conditions has been shown on the drawing of figure 7. In applying the system it is only

necessary to multiply the ratio of feed to radiation resistance (given in the figures to the right of the suggested operating dimensions in figure 7) by the radiation resistance of the antenna system to obtain the impedance of the cable to be used in feeding the array. Approximate values of radiation resistance for a number of commonly used parasitic-element arrays are given in figure 5.

In many cases it will be desired to use the folded-element or yoke matching system with different sizes of conductors or different spacings than those shown in figure 7. Note, then, that the impedance transformation ratio of these types of matching systems is dependent *both on the ratio of conductor diameters and on their spacing*. The following equation may be used for the determination of the impedance transformation when using different diameters in the two sections of a folded element:

$$\text{Transformation ratio} = \left(1 + \frac{Z_1}{Z_2} \right)^2$$

In this equation Z_1 is the characteristic impedance of a line made up of the smaller of the two conductor diameters spaced the center-to-center distance of the two con-

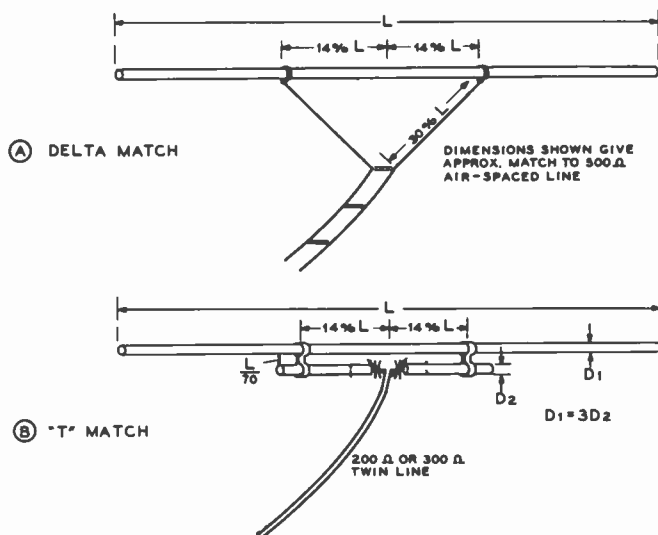

Figure 8
AVERAGE DIMENSIONS
FOR THE DELTA AND
"T" MATCH

ductors in the antenna, and Z_2 is the characteristic impedance of a line made up of two conductors the size of the larger of the two. This assumes that the feed line will be connected in series with the *smaller* of the two conductors so that an impedance step-up of greater than four will be obtained. If an impedance step-up of less than four is desired, the feed line is connected in series with the *larger* of the two conductors and Z_1 in the above equation becomes the impedance of a hypothetical line made up of the larger of the two conductors and Z_2 is made up of the smaller. The folded vhf unipole is an example where the transmission line is connected in series with the larger of the two conductors.

The Delta Match and the T-Match The *delta match* and the *T-match* are shown in figure 8. The delta match has been largely superseded by the newer T-match, however, both these systems can be adjusted to give a low value of SWR on 50- to 600-ohm balanced transmission lines. In the case of the systems shown it will be necessary to make adjustments in the tapping distance along the driven radiator until minimum standing waves on the antenna transmission line are obtained. Since it is sometimes impractical to eliminate completely the standing waves from the antenna

transmission line when using these matching systems, it is common practice to cut the feed line, after standing waves have been reduced to a minimum, to a length which will give satisfactory loading of the transmitter over the desired frequency range of operation.

The inherent reactance of the T-match is tuned out by the use of two identical resonating capacitors in series with each leg of the T-rod. These capacitors should each have a maximum capacity of 8 pf per meter of wavelength. Thus for 20 meters, each capacitor should have a maximum capacitance of at least 160 pf. For power up to a kilowatt, 1000-volt spacing of the capacitors is adequate. These capacitors should be tuned for minimum SWR on the transmission line. The adjustment of these capacitors should be made at the same time the correct setting of the T-match rods is made as the two adjustments tend to be interlocking. The use of the standing-wave meter (described in Test Equipment chapter) is recommended for making these adjustments to the T-match.

Feed Systems Using a Driven Element with Center Feed Four methods of exciting the driven element of a parasitic array are shown in figure 9. The system shown at A has proven to be quite satisfac-

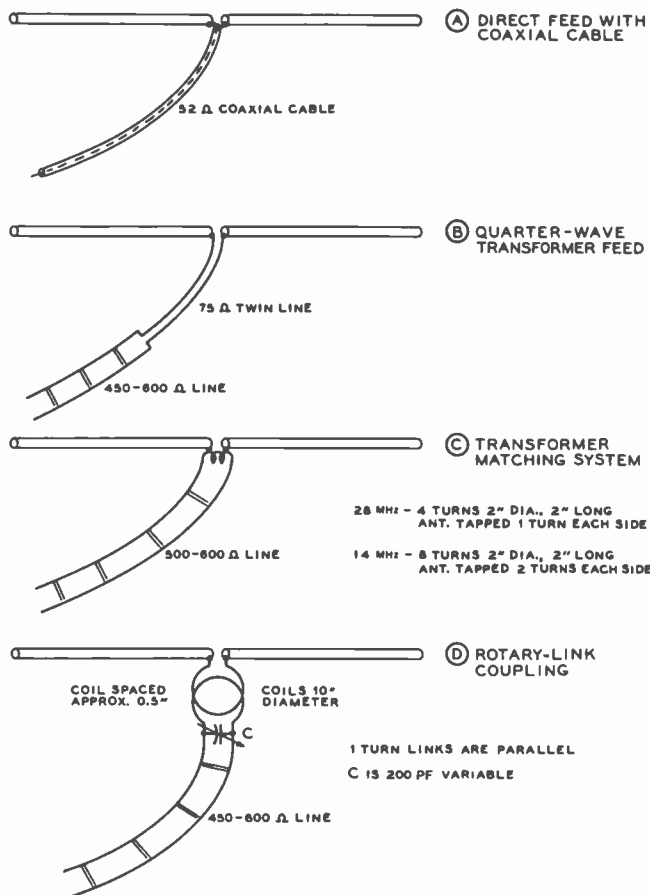

Figure 9
ALTERNATE FEED
METHODS WHERE THE
DRIVEN ELEMENT MAY
BE BROKEN IN THE
CENTER

tory in the case of an antenna-reflector two-element array or in the case of a three-element array with 0.2 to 0.25 wavelength spacing between the elements of the antenna system. The feed-point impedance of the center of the driven element is close enough to the characteristic impedance of the 52-ohm coaxial cable that the standing-wave ratio on the 52-ohm coaxial cable is less than 2-to-1. B shows an arrangement for feeding an array with a broken driven element from an open-wire line with the aid of a quarter-wave matching transformer.

Rotary-Link Coupling In many cases it is desirable to be able to allow the antenna array to rotate continuously without regard to snarling of the feed line. If this is to be done some sort of slip rings or

rotary joint must be made in the feed line. One relatively simple method of allowing unrestrained rotation of the antenna is to use the method of *rotary-link coupling* shown in figure 9D. The two coupling rings are 10 inches in diameter and are usually constructed of 1/4-inch copper tubing supported one from the rotating structure and one from the fixed structure by means of standoff insulators. The capacitor (C in figure 9D) is adjusted, after the antenna has been tuned, for minimum standing-wave ratio on the antenna transmission line. The dimensions shown will allow operation with either 14- or 28-MHz elements, with appropriate adjustment of capacitor C. The rings must of course be parallel and must lie in a plane normal to the axis of rotation of the rotating structure.

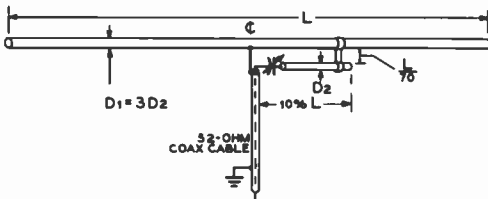

Figure 10

THE GAMMA MATCHING SYSTEM

See text for details of resonating capacitor

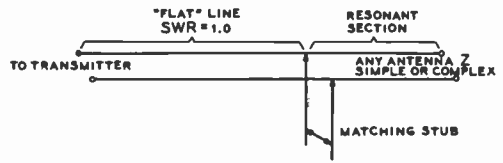

Figure 11

IMPEDANCE MATCHING WITH A CLOSED STUB ON A TWO-WIRE TRANSMISSION LINE

The Gamma Match The use of coaxial cable to feed the driven element of a yagi array is becoming increasingly popular. One reason for this increased popularity lies in the fact that the TVI-reduction problem is simplified when coaxial feed line is used from the transmitter to the antenna system. Radiation from the feed line is minimized when coaxial cable is used, since the outer conductor of the line may be grounded at several points throughout its length and since the intense field is entirely confined within the outer conductor of the coaxial cable. Other advantages of coaxial cable as the antenna feed line lie in the fact that coaxial cable may be run within the structure of a building without danger, or the cable may be run underground without disturbing its operation. Also, transmitting-type low-pass filters for 52-ohm impedance are more widely available and are less expensive than equivalent filters for two-wire line.

The *gamma-match* is illustrated in figure 10, and may be considered as one-half of a T-match. One resonating capacitor is used, placed in series with the gamma rod. The capacitor should have a capacity of 7 pf per meter of wavelength. For 15-meter operation the capacitor should have a maximum capacitance of 105 pf. The length of the gamma rod determines the impedance transformation between the transmission line and the driven element of the array, and the gamma capacitor tunes out the inductance of the gamma rod. By adjustment of the length of the gamma rod, and the setting of the gamma capacitor, the SWR on the coaxial line may be brought to a very low value at the chosen operating frequency.

The Matching Stub If an open-wire line is used to feed a low-impedance radiator, a section of the transmission line may be employed as a matching stub as shown in figure 11. The matching stub can transform any complex impedance to the characteristic impedance of the transmission line. While it is possible to obtain a perfect match and good performance with either an open stub or a shorted one by observing appropriate dimensions, a shorted stub is much more readily adjusted. Therefore, the following discussion will be confined to the problem of using a closed stub to match a low-impedance load to a high-impedance transmission line.

If the transmission line is so elevated that adjustment of a "fundamental" shorted stub cannot be accomplished easily from the ground, then the stub length may be increased by exactly one or two electrical half wavelengths, without appreciably affecting its operation.

While the correct position of the shorting bar and the point of attachment of the stub to the line can be determined entirely by experimental methods, the fact that the two adjustments are interdependent, or interlocking, makes such a cut-and-try procedure a tedious one. Much time can be saved by determining the approximate adjustments required by reference to a chart such as figure 12 and using them as a starter. Usually only a slight "touching up" will produce a perfect match and flat line.

In order to utilize figure 12, it is first necessary to locate accurately a voltage node or current node on the line in the vicinity that has been decided on for the stub, and also to determine the SWR.

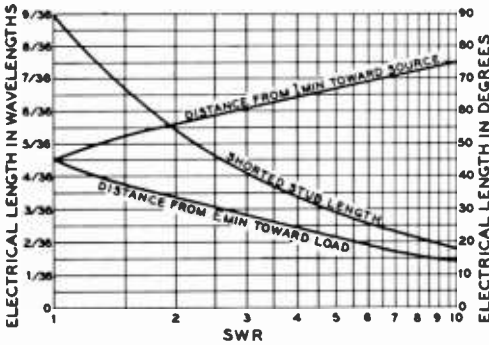

Figure 12

SHORTED-STUB LENGTH AND POSITION CHART

From the standing-wave ratio and current or voltage null position it is possible to determine the theoretically correct length and position of a shorted stub. In actual practice a slight discrepancy usually will be found between the theoretical and the experimentally optimized dimensions; therefore it may be necessary to "touch up" the dimensions after using the above data as a starting point.

Stub adjustment becomes more critical as the SWR increases, and under conditions of high SWR the current and voltage nulls are more sharply defined than the current and voltage maxima, or loops. Therefore, it is best to locate either a current null or voltage null, depending on whether a current-indicating device or a voltage-indicating device is used to check the standing-wave pattern.

The SWR is determined by means of a directional coupler, or by noting the ratio of E_{max} to E_{min} or I_{max} to I_{min} as read on an indicating device.

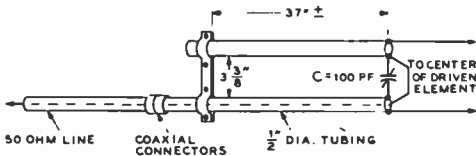

Figure 13

COAXIAL STUB BALUN FOR 14-MHz BEAM

Matching stub and balun are combined to provide balanced feed point for a 50-ohm transmission line to match low-impedance driven element. Balun is designed to be mounted on beam, at the center of driven element using short, heavy interconnecting leads.

It is assumed that the characteristic impedance of the section of line used as a stub is the same as that of the transmission line proper. It is preferable to have the stub section identical to the line physically as well as electrically.

A Stub Balun for a 14-MHz Yagi Beam A short, loaded matching stub may be combined with a balun transformer to provide a good match between a 50-ohm coaxial line and a low-impedance feedpoint of a typical 3-element 20-meter parasitic beam antenna (figure 13). The unit shown is designed to match a load impedance in the range of 17 to 25 ohms.

The stub balun is built of two sections of 1/2-inch diameter tubing. One section is about 40" long, and the other section is about 44" long and has a coaxial receptacle on one end. The tubes are separated about 3 3/8". An adjustable shorting bar is placed at the transmission-line end of the assembly. A short length of RG-8/U coaxial line, with the outer jacket and braid removed is run from the coaxial receptacle, through the longer tube and out the free end. The wire is left long enough to cross-connect to the opposite balun tube. A variable capacitor is placed across the free end of the balun, as shown.

The balun is placed directly at the center of the driven element of the beam antenna. Length of the balun, the capacitance setting, and length of the driven element are the variables that determine the impedance match. Adjustment of these variables can provide a unity match at the resonant frequency of the array. The variable capacitor should be mounted in a waterproof box to protect it from moisture.

24-4 Unidirectional Driven Arrays

Three types of unidirectional driven arrays are illustrated in figure 14. The array shown in figure 14A is an end-fire system which may be used in place of a parasitic array of similar dimensions when greater frequency coverage than is available with the yagi type is desired. Figure 14B is a combination end-fire and collinear system

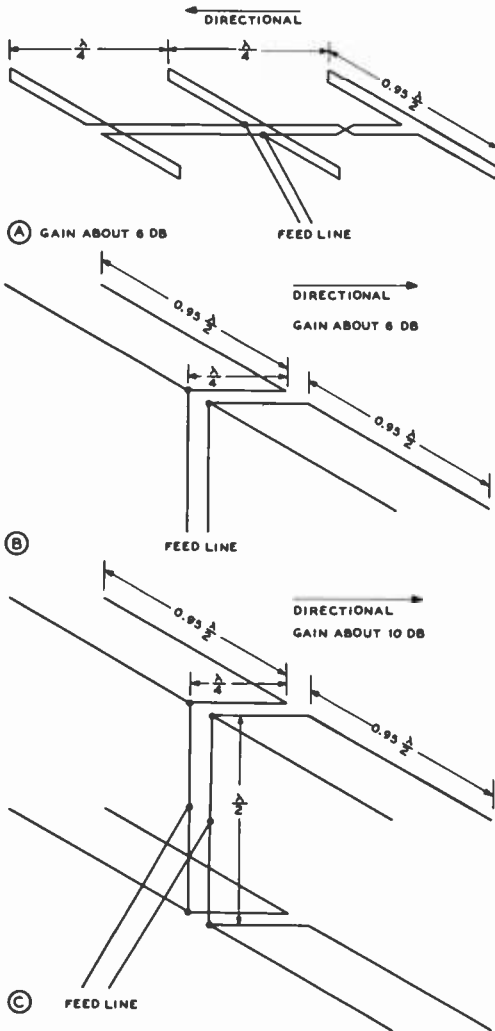

Figure 14

UNIDIRECTIONAL ALL-DRIVEN ARRAYS

A unidirectional all-driven end-fire array is shown at A. B shows an array with two half waves in phase with driven reflectors. A lazy-H array with driven reflectors is shown at C. Note that the directivity is through the elements with the greatest total feed-line length in arrays such as shown at B and C.

which will give approximately the same gain as the system of figure 14A, but which requires less boom length and greater total element length. Figure 14C illustrates the familiar lazy-H with driven reflectors (or directors, depending on the point of view)

in a combination which will show wide bandwidth with a considerable amount of forward gain and good front-to-back ratio over the entire frequency coverage.

A simple driven array is the so-called *ZL Special*, which is one-half the array of figure 14B. The *ZL Special* is fed at the center point of the half-wave elements and provides a cardioid pattern with a gain of about 3 decibels.

Unidirectional Stacked Broadside Arrays

Three practical types of unidirectional stacked broadside arrays are shown in figure 15. The first type, shown at figure 15A, is the simple lazy-H type of antenna with parasitic reflectors for each element. Figure 15B shows a simpler antenna array with a pair of folded dipoles spaced one-half wave vertically, operating with reflectors. In figure 15C is shown a more complex array with six half waves and six reflectors which will give a very worthwhile amount of gain.

In all three of the antenna arrays shown the spacing between the driven elements and the reflectors has been shown as one-quarter wavelength. This has been done to eliminate the requirement for tuning of the reflector, as a result of the fact that a half-wave element spaced exactly one-quarter wave from a driven element will make a unidirectional array when both elements are the same length. Using this procedure will give a gain of 3 db with the reflectors over the gain without the reflectors, with only a moderate decrease in the radiation resistance of the driven element. Actually, the radiation resistance of a half-wave dipole goes down from 73 ohms to 60 ohms when an identical half-wave element is placed one-quarter wave behind it.

A very slight increase in gain for the entire array (about 1 db) may be obtained at the expense of lowered radiation resistance, the necessity for tuning the reflectors, and decreased bandwidth by placing the reflectors 0.15 wavelength behind the driven elements and making them somewhat longer than the driven elements. The radiation resistance of each element will drop approximately to one-half the value obtained with untuned half-wave reflectors spaced one-quarter wave behind the driven elements.

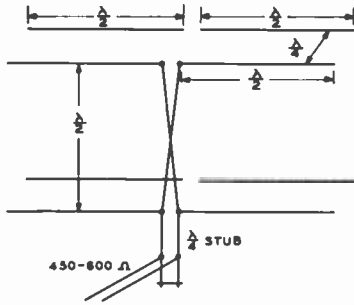

(A)
"LAZY H" WITH REFLECTOR

GAIN APPROX. 9 DB

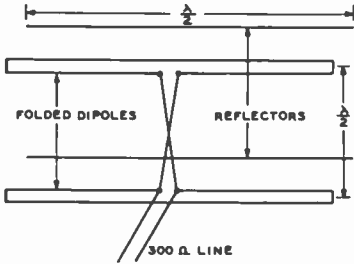

(B)
BROADSIDE HALF-WAVES
WITH REFLECTORS

GAIN APPROX. 7 DB

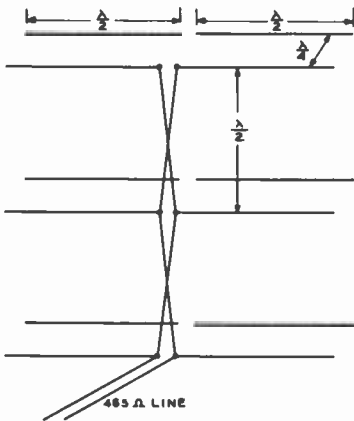

(C)
"TWO OVER TWO"
WITH REFLECTORS

GAIN APPROX. 11.5 DB

Figure 15
BROADSIDE ARRAYS
WITH PARASITIC
REFLECTORS

The apparent gain of the arrays illustrated will be greater than the values given due to concentration of the radiated signal at the lower elevation angles.

Antenna arrays of the type shown in figure 15 require the use of some sort of lattice work for the supporting structure since the arrays occupy appreciable distance in space in all three planes.

Feed Methods The requirements for the feed systems for antenna arrays of the type shown in figure 15 are less critical than those for the close-spaced parasitic arrays shown in the previous section. This is a natural result of the fact that a larger number of the radiating elements are directly fed with energy, and of the fact that the effective radiation resistance of each of the

driven elements of the array is much higher than the feed-point resistance of a parasitic array. As a consequence of this fact, arrays of the type shown in figure 15 can be expected to cover a somewhat greater frequency band for a specified value of standing-wave ratio than the parasitic type of array.

In most cases a simple open-wire line may be coupled to the feed point of the array without any matching system. The standing-wave ratio with such a system of feed will often be less than 2-to-1. However, if a more accurate match between the antenna transmission line and the array is desired a

conventional quarter-wave stub, or a quarter-wave matching transformer of appropriate impedance, may be used to obtain a low standing-wave ratio.

24-5 Construction of Rotatable Arrays

A considerable amount of ingenuity may be exercised in the construction of the supporting structure for a rotatable array. Every person has his own ideas as to the best method of construction. Often the most practical method of construction will be dictated by the availability of certain types of construction materials, but in any event be sure that sound mechanical engineering principles are used in the design of the supporting structure. There are few things quite as discouraging as the picking up of pieces, repairing of the roof, etc., when a newly constructed rotary comes down in the first strong wind. If the principles of mechanical engineering are understood it is wise to calculate the loads and torques which will exist in the various members of the structure with the highest wind velocity which may be expected in the locality of the installation. If this is not possible it will usually be worth the time and effort to look up a friend who understands these principles.

Radiating Elements One thing more or less standard about the construction of rotatable antenna arrays is the use of dural tubing for the self-supporting elements. Other materials may be used but an alloy known as 2024 has proven over a period of time to be quite satisfactory. Copper tubing is too heavy for a given strength, and steel tubing, unless copper plated, is likely to add an undesirably large loss resistance to the array. Also, steel tubing, even when plated, is not likely to withstand salt atmosphere (such as is encountered along the seashore) for a satisfactory period of time. Do not use a soft aluminum alloy for the elements unless they will be quite short; 2024 is a hard alloy and is noncorrosive. Alloy 2017 and 6061 are also satisfactory, cheaper, and easier to obtain. Do not use alloys 5052, 2014, or 3003 (EMT), as these signify alloys which have not been heat

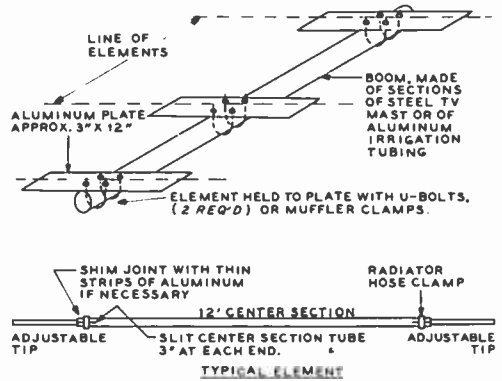

Figure 16

3-ELEMENT ALL-METAL ANTENNA ARRAY

All-metal configuration permits rugged, light assembly. Joints are made with U-bolts and metal plates for maximum rigidity.

treated for strength and rigidity. However, these softer alloys, and aluminum electrical conduit, may be used for short radiating elements such as would be used for the 50-MHz band or as interconnecting conductors in a stacked array.

All-Metal Construction It is characteristic of the conventional type of multielement parasitic array, such as discussed previously and outlined, that the centers of all the elements are at zero r-f potential with respect to ground. It is therefore possible to use a metallic structure without insulators for supporting the various elements of the array. A typical three-element array of this type is shown in figure 16. In this particular array, U-bolts and metal plates have been employed to fasten the elements to the boom. The elements are made of telescoping sections of aluminum tubing. The tips of the inner sections of tubing are split, and a tubing clamp is slipped over the joint, as shown in the drawing. Before assembly of the point, the mating pieces of aluminum are given a thin coat of *Penetrox-A* compound. (This antioxidizing paste is manufactured by *Burdny Co.*, Norwalk, Conn. and is distributed by the *General Electric Supply*

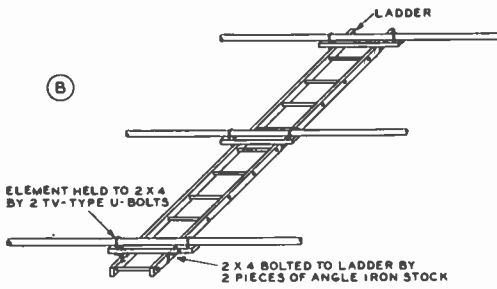

Figure 17

ALTERNATIVE WOODEN SUPPORTING ARRANGEMENT

A wooden ladder may be used to support a 10 or 15 meter array.

Co.) When the tubes are telescoped and the clamp is tightened, an airtight seal is produced, reducing corrosion to a minimum.

The boom of the parasitic array may be made from two or three sections of steel TV mast, or it may be made of a single section of aluminum irrigation pipe. This pipe is made by *Reynolds Aluminum Co.*, and others, and may often be purchased via the *Scars, Roebuck Co.* mail-order department. Three-inch pipe may be used for the 10- and 15-meter antennas, and the huskier four-inch pipe should be used for a 20-meter beam.

Automobile muffler clamps can often be used to affix the elements to the support plates. Larger clamps of this type will fasten the plates to the boom. In most cases, the muffler clamps are untreated, and they should be given one or two coats of rust-proof paint to protect them from inclement weather. All bolts, nuts, and washers used in the assembly of the array should be of the plated variety to reduce corrosion and rust.

If it is desired to use a split driven element for a balanced feed system, it is necessary to insulate the element from the supporting structure of the antenna. The element should be severed at the center, and the two halves driven onto a wooden dowel. The element may then be mounted on an aluminum support plate by means of four ceramic insulators. Metal-based insulators,

such as the *Johnson 135-67* are recommended, since the all-ceramic types may break at the mounting holes when the array is subject to heavy winds.

24-6 Tuning the Array

Although satisfactory results may be obtained by precutting the antenna array to dimensions given earlier in this chapter, the occasion might arise when it is desired to make a check on the operation of the antenna before calling the job complete.

The process of tuning an array may satisfactorily be divided into two more or less distinct steps: the actual tuning of the array for best front-to-back ratio or for maximum forward gain, and the adjustment to obtain the best possible impedance match between the antenna transmission line and the feed point of the array.

Tuning the Array The actual tuning of the array for best front-to-back ratio or maximum forward gain may best be accomplished with the aid of a low-power transmitter feeding a dipole antenna (polarized the same as the array being tuned) at least four or five wavelengths away from the antenna being tuned and located at the same elevation as that of the antenna under test. A calibrated field-strength meter of the remote-indicating type is then coupled to the feed point of the antenna array being tuned. The transmissions from the portable transmitter should be made as short as possible and the call sign of the station making the test should be transmitted at least every ten minutes.

One satisfactory method of tuning the array proper, assuming that it is a system with several parasitic elements, is to set the directors to the dimensions given in figure 5 and then to adjust the reflector for maximum forward signal. Then the first director should be varied in length until maximum forward signal is obtained, and so on if additional directors are used. Then the array may be reversed in direction and the reflector adjusted for best front-to-back ratio. Subsequent small adjustments may then be made in both the directors and the reflector for best forward signal with a reasonable ratio of front-to-back signal. The adjust-

ments in the directors and the reflector will be found to be interdependent to a certain degree, but if small adjustments are made after the preliminary tuning process a satisfactory set of adjustments for maximum performance will be obtained. It is usually best to make the end sections of the elements smaller in diameter so that they will slip inside the larger tubing sections. The smaller sliding sections may be clamped inside the larger main sections.

Matching to the Antenna Transmission Line The problem of matching the impedance of the antenna transmission line to

the array is much simplified if the process of tuning the array is made a substantially separate process as just described. After the tuning operation is complete, the resonant frequency of the driven element of the antenna should be checked, directly at the center of the driven element if practical, with a grid-dip meter. It is important that the resonant frequency of the antenna be at the center of the frequency band to be covered. If the resonant frequency is found to be much different from the desired frequency, the length of the driven element of the array should be altered until this condition exists. A relatively small change in the length of the driven element will have only a parasitic-order effect on the tuning of the parasitic elements of the array. Hence, a moderate change in the length of the driven element may be made without repeating the tuning process for the parasitic elements.

When the resonant frequency of the antenna system is correct, the antenna transmission line, with impedance-matching device or network between the line and antenna feed point, is then attached to the array and coupled to a low-power exciter unit or transmitter. Then, preferably, a standing-wave meter is connected in series with the antenna transmission line at a point relatively much closer to the transmitter than to the antenna.

If the standing-wave ratio is below 1.5 to 1 it is satisfactory to leave the installation as it is. If the ratio is greater than this range it will be best when twin line or coaxial line is being used, and advisable with open-wire line, to attempt to decrease the SWR.

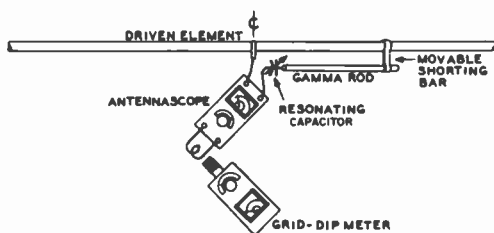

Figure 18

ADJUSTMENT OF GAMMA MATCH BY USE OF ANTENNASCOPE AND GRID-DIP METER

It must be remembered that no adjustments made at the transmitter end of the transmission line will alter the SWR on the line. All adjustments to better the SWR must be made at the antenna end of the line and to the device which performs the impedance transformation necessary to match the characteristic impedance of the antenna to that of the transmission line.

Before any adjustments to the matching system are made, the resonant frequency of the driven element must be ascertained, as explained previously. If all adjustments to correct impedance mismatch are made at this frequency, the problem of reactance termination of the transmission line is eliminated, greatly simplifying the problem. The following steps should be taken to adjust the impedance transformation:

1. The output impedance of the matching device should be measured. An Antennascope and a grid-dip oscillator are required for this step. The Antennascope is connected to the output terminals of the matching device. If the driven element is a folded dipole, the Antennascope connects directly to the split section of the dipole. If a gamma match or T-match is used, the Antennascope connects to the transmission-line end of the device. If a Q-section is used, the Antennascope connects to the bottom end of the section. The grid-dip oscillator is coupled to the input terminals of the Antennascope as shown in figure 18.
2. The grid-dip oscillator is tuned to the resonant frequency of the antenna,

which has been determined previously, and the Antennascope control is turned for a null reading on the meter of the Antennascope. The impedance presented to the Antennascope by the matching device may be read directly on the calibrated dial of the Antennascope.

- Adjustments should be made to the matching device to present the desired impedance transformation to the Antennascope. If a folded dipole is used as the driven element, the transformation ratio of the dipole must be varied as explained previously in this chapter to provide a more exact match. If a T-match or gamma match system is used, the length of the matching rod may be changed to effect a proper match. If the Antennascope ohmic reading is *lower* than the desired reading, the length of the matching rod should be *increased*. If the Antennascope reading is *higher* than the desired reading, the length of the matching rod should be *decreased*. After each change in length of the matching rod, the series capacitor in the matching system should be re-resonated for best null on the meter of the Antennascope.

Raising and Lowering the Array A practical problem always present when tuning up and matching an array is the physical location of the structure. If the array is atop the mast it is inaccessible for adjustment, and if it is located on stepladders where it can be adjusted easily it cannot be rotated. One encouraging factor in this situation is the fact that experience has shown that if the array is placed 8 or 10 feet above ground on some stepladders for the preliminary tuning process, the raising of the system to its full height will not produce a serious change in the adjustments. So it is usually possible to make preliminary adjustments with the system located slightly greater than head height above ground, and then to raise the antenna to a position where it may be rotated for final adjustments. If the position of the matching device as determined near the ground is marked so that the adjustments will not be lost, the array

may be raised to rotatable height and the fastening clamps left loose enough so that the elements may be slid in by means of a long bamboo pole. After a series of trials a satisfactory set of adjustments can be obtained.

The matching process does not require rotation, but it does require that the antenna proper be located at as nearly its normal operating position as possible. However, on a particular installation the standing-wave ratio on the transmission line near the transmitter may be checked with the array in the air, and then the array may be lowered to ascertain whether or not the SWR has changed. If it has not, and in most cases if the feeder line is strung out back and forth well above the ground as the antenna is lowered they will not change, the last adjustment may be determined, the standing-wave ratio again checked, and the antenna re-installed in its final location.

24-7 Indication of Direction

The most satisfactory method for indicating the direction of transmission of a rotatable array is that which uses *Selsyns* or *Synchros* for the transmission of the data from the rotating structure to the indicating pointer at the operating position. A number of Synchros and Selsyns of various types are available on the surplus market. Some of them are designed for operation on 115 volts at 60 Hertz, some are designed for operation on 60 Hertz but at a lowered voltage, and some are designed for operation from 400-Hertz or 800-Hertz energy. This latter type of high-frequency Selsyn is the most generally available type, and the high-frequency units are smaller and lighter than the 60-Hertz units. Since the indicating Selsyn must deliver an almost negligible amount of power to the pointer which it drives, the high-frequency types will operate quite satisfactorily from 60-Hertz power if the voltage on them is reduced to somewhere between 6.3 and 20 volts. In the case of many of the units available, a connection sheet is provided along with a recommendation in regard to the operating voltage when they are run on 60 Hertz. In any event the operating voltage should be held as low as it may be and still give satisfactory transmission of data from the antenna to the operat-

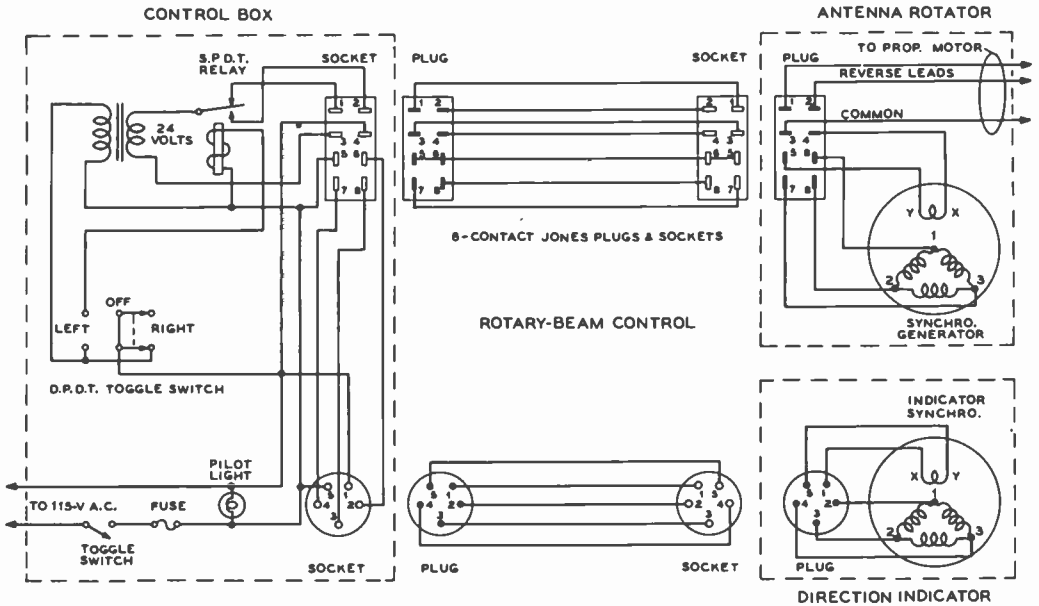

Figure 19

SCHEMATIC OF A COMPLETE ANTENNA CONTROL SYSTEM

ing position. Certainly it should not be necessary to run such a voltage on the units that they become overheated.

A suitable Selsyn indicating system is shown in figure 19.

Systems using a potentiometer capable of continuous rotation and a millimeter, along with a battery or other source of direct current, may also be used for the indication of direction.

24-8 Three-Band Beams

A popular form of beam antenna introduced during the past few years is the so-called *three-band beam*. An array of this type is designed to operate on three adjacent amateur bands, such as the 10-, 15-, and 20-meter group. The principle of operation of this form of antenna is to employ parallel-tuned circuits placed at critical positions in the elements of the beam which serve to electrically connect and disconnect the outer sections of the elements as the frequency of excitation of the antenna is changed. A typical three-band element is shown in figure 20. At the lowest operating frequency, the tuned *traps* exert a minimum

influence on the element which resonates at a frequency determined by the electrical length of the configuration, plus a slight degree of loading contributed by the traps. At some higher frequency (generally about 1.5 times the lowest operating frequency) the outer set of traps is in a parallel resonant condition, placing a high impedance between the element and the tips beyond the traps. Thus, the element resonates at a frequency 1.5 times higher than that deter-

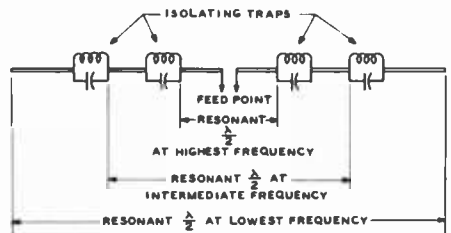

Figure 20

TRAP-TYPE "THREE BAND" ELEMENT

Isolating traps permit dipole to be self-resonant at three widely different frequencies.

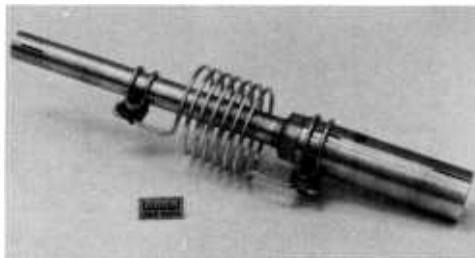

Figure 21

HIGH-Q ISOLATING TRAP

This trap has a Q of nearly 300 and is well suited for multiband antennas. The coil is wound of No. 8 aluminum clothesline wire and is 3" in diameter and 3" long. The 15-meter trap has seven turns (illustrated) and the 10-meter trap has five turns. The capacitor is made from two lengths of aluminum tubing, coaxially aligned in a lucite dielectric. Capacitor length is about five inches and tubing sizes are 3/4 inch and 1-1/4 inch. Capacitance is about 25 pf. Lucite projects from end of capacitor to form 1/2-inch collar which is coated with epoxy to prevent deterioration of the dielectric under exposure to sunlight. Similar traps have been made using teflon as a dielectric material. Ends of aluminum tubes are slotted to facilitate assembly to antenna elements.

mined by the overall length of the element. As the frequency of operation is raised to approximately 2.0 times the lowest operating frequency, the inner set of traps becomes resonant, effectively disconnecting a larger portion of the element from the driven section. The length of the center section is resonant at the highest frequency of operation. The center section, plus the two adjacent inner sections are resonant at the intermediate frequency of operation, and the complete element is resonant at the lowest frequency of operation.

The efficiency of such a system is determined by the accuracy of tuning of both the element sections and the isolating traps. In addition the combined dielectric losses of the traps affect the overall antenna efficiency. As with all multipurpose devices, some compromise between operating convenience and efficiency must be made with antennas designed to operate over more than one narrow band of frequencies. Taking into account the theoretical difficulties that must be overcome it is a tribute to the designers of the better multiband beams that they perform as well as they do.

The Isolating Trap The parallel-tuned circuit which serves as an isolating trap for a multiband antenna should combine high circuit Q with good environmental protection. A highly satisfactory trap configuration based on the original design of W3DZZ is shown in figure 21. The trap capacitor, which has a value of about 25 pf, is made of two sections of aluminum tubing which form a portion of the antenna element. The capacitor dielectric is moulded lucite, or similar plastic material, given a coat of epoxy to help resist crazing and cracking caused by exposure to sunlight. The coil is wound of No. 8 aluminum wire and, with the capacitor placed within it, has a Q of nearly 300. The leads of the coil are bent around the tubing and a small aluminum block is used to form an inexpensive clamp. If desired, an aluminum cable clamp may be substituted for the homemade device.

The isolating trap is usually tuned to the lower edge of an amateur band, rather than to the center, to compensate for the length of the unit. In general, the 15-meter trap is tuned to approximately 20.8 MHz and the 10-meter trap is tuned near 27.8 MHz. The trap frequency is not critical within a few hundred kilohertz. Resonance is established by squeezing or expanding the turns of the coil while the trap is resonated on the bench with a grid-dip oscillator and a calibrated receiver.

A substitute for the moulded capacitor may be made up of two 40 pf, 5-kv ceramic capacitors connected in series (*Centralab 850S-50Z*) and mounted in a length of phenolic tubing of the proper diameter to slip within the aluminum antenna sections. The trap coil is then wound about the capacitor assembly in the manner shown in the photograph.

24-9 Lumped Baluns for Beam Antennas

A broadband coaxial balun was described in Chapter 20 of this Handbook. Baluns having similar broadband characteristics may be wound of wire on either air or ferrite cores, as shown in figure 22. The air-core design is rated for 2 kW PEP and maintains

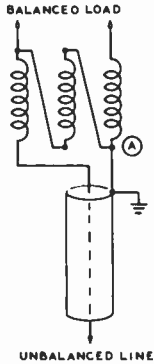

Figure 22

BROADBAND BALUN FOR BEAM ANTENNA

A trifilar balun may be used to match a 50-ohm coaxial line to a split driven element having an impedance of 15 to 50 ohms. Airwound balun consists of ten turns #14 Formvar insulated wire, wound on piece of 1-1/16" diameter plastic pipe, 4" long. Polyvinyl Chloride (PVC) pipe used for water pipe is satisfactory. Three windings are made, the wires placed in parallel, and wound side by side on the form as one, until ten trifilar turns are on the form.

Ferrite-core balun is composed of 6 turns #14 Formvar wire, trifilar wound on Q-1 material, 1/2" diameter. Use Indiana General CF-503 ferrite and break to proper length by nicking with file around the circumference and striking a hard blow. (Available Newark Electric Co., Chicago, part number 59F-1521).

a low value of SWR in the antenna system over a frequency range of 7 to 29.7 MHz. The balun may also be used at 80 meters, however, since it only exerts a slight detuning effect on the antenna.

The ferrite-core balun is designed for operation over the range of 3.5 to 29.7 MHz. While smaller in size than the air-core unit, the ferrite-core balun is power limited to about 200 watts at the high-frequency end of the operational range.

The baluns are trifilar wound, that is, three separate windings are placed on the form in parallel and then connected as

shown in the illustration. The input terminals of the balun are nonsymmetrical; point A at the input end being taken as ground. Transposition of the input connections will degrade balancing action. Either end of the unit may be taken as the input, provided point A (the common connection of two windings) is ground.

When completed, the baluns should be protected from moisture by placing them within a waterproof, nonmetallic container. A plastic "squeeze bottle" may be used, with wooden discs cut for the ends and held in place with small screws.

Mobile Equipment Design and Installation

Mobile operation is permitted on all amateur bands. Tremendous impetus to this phase of the hobby was given by the suitable design of compact mobile equipment. Complete mobile installations may be purchased as packaged units, or the whole mobile station may be home built, according to the whim of the operator.

The problems involved in achieving a satisfactory two-way installation vary somewhat with the band, but many of the problems are common to all bands. For instance, ignition noise is more troublesome on 10 meters than on 80 meters, but on the other hand an efficient antenna system is much more easily accomplished on 10 meters than on 80 meters. Also, obtaining a worthwhile amount of transmitter output without excessive battery drain is a problem on all bands.

Specialized mobile equipment is available for operation on the 2- and 6-meter bands and a small amount of mobile use is made of the 432-MHz band. The availability of surplus equipment, moreover, has stimulated f-m mobile activity, especially on 2 meters, where the use of fixed f-m repeaters placed on elevated locations has done much to enhance vhf mobile operation.

The majority of high-frequency mobile operation takes place on single sideband. The low duty-cycle of SSB equipment, as con-

trasted to the heavy power drain of conventional a-m gear has encouraged the use of relatively high-power sideband equipment in many mobile installations. The rigid frequency stability requirement for satisfactory SSB reception, however, has obsoleted the once-popular tuned-converter and auto-receiver combination formerly used for a-m reception. Transistor, crystal-controlled converters have attained some measure of popularity when combined with transistor auto radios for casual mobile reception of amateur signals. If the converter includes a demodulating bfo, it may be used for satisfactory SSB reception.

25-1 Mobile Converters

A One-Transistor Converter This inexpensive and easily constructed single-transistor, crystal-controlled mobile converter may be used in conjunction with a transistor auto radio or portable transistor radio for a-m reception on frequencies up to 20 MHz or so. The converter is powered by a single 9-volt miniature battery and provides satisfactory reception when used in conjunction with a mobile whip antenna.

The schematic of the converter is shown in figure 1. An inexpensive "entertainment-

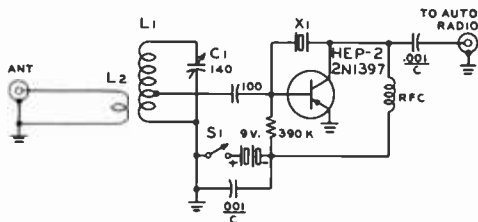

Figure 1

SINGLE TRANSISTOR MOBILE CONVERTER

L₁—80 meters; approx. 15 μ H. (J. W. Miller 42A155-CB1, $\frac{3}{8}$ " diam. with powdered-iron slug).

40 meters; approx. 5 μ H. (J. W. Miller 42A476-CB1)

20 meters; approx. 2 μ H. (J. W. Miller 42A226-CB1)

15 meters; approx. 1 μ H. (J. W. Miller 42A106-CB1)

L₂—Adjust for maximum signal strength. Approximately 6 turns for 80 meters, 4 turns for 40 meters, 3 turns for 20 meters and 2 turns for 15 meters. Wind around ground end of L₁, using #22 d.c.c. wire.

RFC—2.5 mH, National R-100 or equivalent.

X₁—Conversion crystal. For amateur band to fall at center of auto radio dial, crystal should be approximately 1 MHz higher or lower in frequency than center of band. Suggested crystal frequencies are: 80 meters, 4.8 MHz; 40 meters, 8.1 MHz; 20 meters, 13.0 MHz; 15 meters, 20 MHz. Fundamental-frequency crystals should be used. For the 20- and 15-meter bands, third-overtone crystals of triple the wanted frequency may be employed, as they will oscillate on their fundamental frequency in this circuit.

type" HEP-2/2N1397 transistor is used in an autodyne converter circuit wherein the transistor serves both as mixer and local oscillator. The incoming signal is impressed on the base circuit via L₁C₁ and a fundamental-frequency crystal serves in a base-collector Pierce oscillator circuit. Output is taken from the untuned collector circuit. Band selection is accomplished by the choice of proper coil and crystal and the high-frequency limit of operation is determined by the highest-frequency fundamental-cut crystal obtainable. The cost of the converter is so moderate that it is better to construct separate converters for each amateur band or desired frequency than to try to make a band-change system for a single converter.

The unit may be built on a section of copper-plated phenolic circuit board and placed in an aluminum utility box. It is suggested that a transistor socket be used to

prevent soldering heat from damaging the transistor.

Operation of the mixing oscillator is checked by monitoring the crystal frequency in a nearby receiver. A test signal at the receiving frequency is then injected in the antenna receptacle and the converter temporarily connected to the station receiver. The input circuit is adjusted for maximum received signal. Experimentation with the number of turns in coupling coil L₂ will ensure maximum antenna coupling to the converter.

A Two-Tube 12-Volt Converter A series of tubes have been developed for mobile service that allow good gain and high sensitivity with only 12 volts on the plate. While these tubes have been largely replaced by transistors in modern auto radios, they still provide excellent service in h-f converters for those amateurs who approach transistors with diffidence.

This crystal-controlled converter may be used on any amateur band between 80 and 6 meters with excellent results, combining circuit simplicity and low cost. The unit uses two high-transconductance 12-volt tubes and requires no external high voltage for operation (figure 2). A 12EK6 serves as an r-f amplifier with contact bias obtained from a high-value grid resistor. No cathode or screen dropping resistors or associated bypass capacitors are required. A 12AD6 pentagrid-converter tube is used as a crystal-controlled local oscillator and mixer. The plate circuit is broadly resonant to 1.0 MHz by virtue of the 1 mH plate r-f choke, the 68-pf coupling capacitor, and the capacitance of the auto radio coupling cable, providing good coupling across the broadcast band while discriminating against noise and image signals that otherwise would tend to overload the car radio.

Band selection is accomplished by choice of coils and crystals, as outlined in the parts list. In addition to amateur band reception, the converter may be used for reception of time signals from WWV or shortwave broadcast signals.

The converter is built on a piece of copper-plated circuit board and placed in a miniature utility box, or a small matching aluminum chassis may serve as a base for

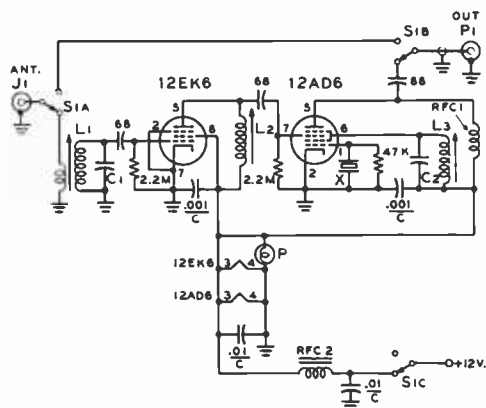

Figure 2

TWO-TUBE, 12-VOLT CONVERTER

C_1, C_2 —20-pf silver mica capacitors

L_1, L_2 —80 meters: approx. 85 μ H. (J. W. Miller 20A825-RBI, 1/4" diam. form with powdered-iron slug). Antenna coil: 15 turns #24 d.c.c. scramble-wound over ground end of L_1 , 40 meters: approx. 26 μ H (J. W. Miller 20A335-RBI) Antenna coil: 8 turns #24 d.c.c. scramble-wound over ground end of L_1 , 20 meters: approx. 6.5 μ H (J. W. Miller 20A686-RBI) Antenna coil: 4 turns #24 d.c.c. scramble-wound over ground end of L_1 , 15 meters: approx. 2.8 μ H. (J. W. Miller 20A336-RBI) Antenna coil: 3 turns #24 d.c.c., as above
10 meters: approx. 1.5 μ H (J. W. Miller 20A157-RBI) (Antenna coil: 3 turns #24 d.c.c., as above
6 meters: approx. 0.5 μ H. (J. W. Miller 20A107-RBI) Antenna coil: 2 turns #24 d.c.c., as above

L_3 —80 meters: approx. 180 μ H. J. W. Miller 21A224-RBI)
40 meters: approx. 50 μ H. (J. W. Miller 21A475-RBI)
20 meters: approx. 13 μ H. (J. W. Miller 21A155-RBI)
15 meters: approx. 6 μ H. J. W. Miller 21A686-RBI)
10 meters: approx. 3 μ H. (J. W. Miller 21A336-RBI)
6 meters: approx. 1 μ H. (J. W. Miller 21A156-RBI)

RFC—2.5 mH. (National R-100 or equiv.)

RFC₁—100- μ H hash choke. (J. W. Miller 5250)

X—Fundamental or overtone crystal. For amateur band to fall at center of auto-radio dial, crystal should be approximately 1 MHz removed from amateur band. Suggested crystal frequencies are: 80 meters, 4.8 MHz; 40 meters, 8.1 MHz; 20 meters, 13.0 MHz; 15 meters, 20 MHz; 10 meters, 27 MHz; 6 meters, 49 MHz

P—12.6-volt pilot lamp

S₁—3-pole, 3-position switch (Centralab PA-2007)

the circuit board. Tube shields should be used and a 12-volt line filter is incorporated in the converter to keep auto noise out of the power lead and to ensure that all sig-

nals reaching the converter do so via the antenna receptacle only.

The mixer stage should be tested first. All coils are tuned to frequency with the aid of a grid-dip oscillator. A nearby receiver tuned to the frequency of the crystal oscillator may serve as a monitor while the slug of coil L_3 is adjusted for reliable oscillation. Once the mixer stage is operating, the r-f circuits may be peaked for maximum signal. When the converter is installed in the automobile and connected to the auto receiver, the output circuit should be peaked for maximum gain with the auto receiver tuned near 1 MHz, and the r-f coils of the converter re-peaked for maximum h-f signal response. Mixer gain is sensitive to the value of grid resistance placed across the crystal and the value may be experimentally changed from that listed to achieve optimum mixer gain, especially on the 10- and 6-meter bands.

25-2 Mobile Power Sources

A small transistor converter for casual listening may be run from a 9-volt battery, but larger mobile receivers, transmitters, and transceivers require power from the electrical system of the automobile. SSB equipment, with its relatively light duty cycle, is ideally suited for mobile use and demands the least primary power drain for a given radiated signal of all the common types of amateur transmission. As a result of the combination of low power requirement and enhanced communication effectiveness, SSB has supplanted amplitude modulation for mobile service on the h-f amateur bands. A.m. on the other hand, is still used (along with f.m.) for vhf mobile service. In any case, a total equipment power drain of about 75 watts for a.m. or f.m. and 250 watts for SSB is about the maximum power that may be taken from the electrical system of an automobile without serious regard to discharging the battery when the car is stopped for *short* periods of mobile operation.

With many SSB mobile-radio installations now requiring 500 to 1000 watts peak power from the automotive electrical system, it is usually necessary to run the car

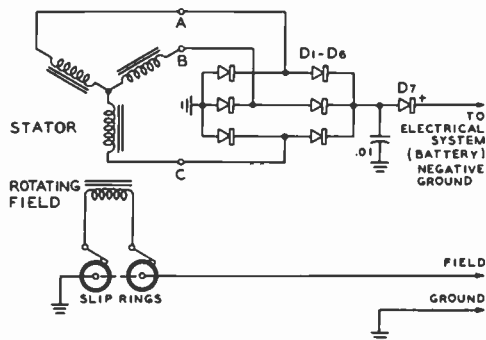

Figure 3

THREE-PHASE AUTOMOBILE ALTERNATOR

Three-phase output voltage is converted to d-c by full wave rectifier D₁, D₂. Rectifier D₇ protects rectifier assembly from transients and voltage surges in electrical system of auto.

engine when the equipment is operated for more than a few minutes at a time to avoid discharging the battery. Fortunately, a majority of automobiles built since 1965 have a 12-volt *alternator system* as standard equipment in place of the less efficient 6- or 12-volt generator charger used in the past. As a result, most SSB transceivers may be run directly from the automotive electrical system without undue strain on the battery during the course of normal driving.

The Alternator A typical alternator circuit is shown in figure 3. The alternator differs from the classic generator in that it uses a rotating field to which d.c. is supplied through slip rings and carbon brushes. Field current is quite low, of the order of 3 amperes or so for many alternators. The rotating field usually has six pairs of poles, and the output of one stator winding represents six electrical cycles for each revolution of the field. The output frequency in cycles per second is one-tenth the shaft speed expressed in revolutions per second.

The high output current of the alternator is supplied directly from the fixed stator windings in the form of three-phase current. The stator is usually connected in a *wye* (Y) configuration to an internal rectifier assembly made up of six silicon diodes which provide full-wave rectification. The ripple

frequency is six times the frequency developed in one winding. Thus, at a shaft speed of 4000 r.p.m., the nominal voltage is 14, output frequency will be 400 Hz, and the ripple frequency is 2400 Hz.

The diode assembly (D₁, D₆) may be mounted on or behind the rear end-bell of the alternator, in conjunction with an isolation diode (D₇) which protects the rectifier assembly from voltage surges and helps to suppress radio noise.

The output voltage of the alternator system is a function of the shaft speed to about 5000 r.p.m. or so. Above this speed, output voltage tends to stabilize because of hysteresis losses. In any case, the alternator output is regulated through adjusting the current in the field by a mechanical voltage regulator or by a solid-state regulator. Because the reverse current through the rectifier diodes is small, the alternator is usually connected directly to the battery without the use of a cutout relay.

Using the Alternator The automotive alternator may be modified to supply 12 volts at 400 Hz for auxiliary equipment. Many alternators are capable of supplying 350 watts of power which, when the battery is charged and the auto accessories are not being used, may be employed to run the mobile gear. A diagram of such an installation is shown in figure 4. Common 60-Hz transformers may be used, or a special 400-Hz three-phase distribution transformer (figure 5). Voltage regulation of the alternator system is very good, although the frequency varies with engine speed, ranging from 100 Hz or so with the engine idling to nearly 1000 Hz at top speed. Modern power transformers, however, even though rated at 60 Hz, are capable of operating efficiently over this range of frequencies.

The schematic of an 1800-volt, 3-phase intermittent-duty SSB kilowatt power supply for mobile service is shown in figure 6. This supply is designed for use with a 1kW PEP linear amplifier using four 811A tubes or two 572B/T-160L tubes.

A solid-state regulator is recommended for use with this supply, since mechanical relay regulators interrupt the alternator field current when the battery is fully charged,

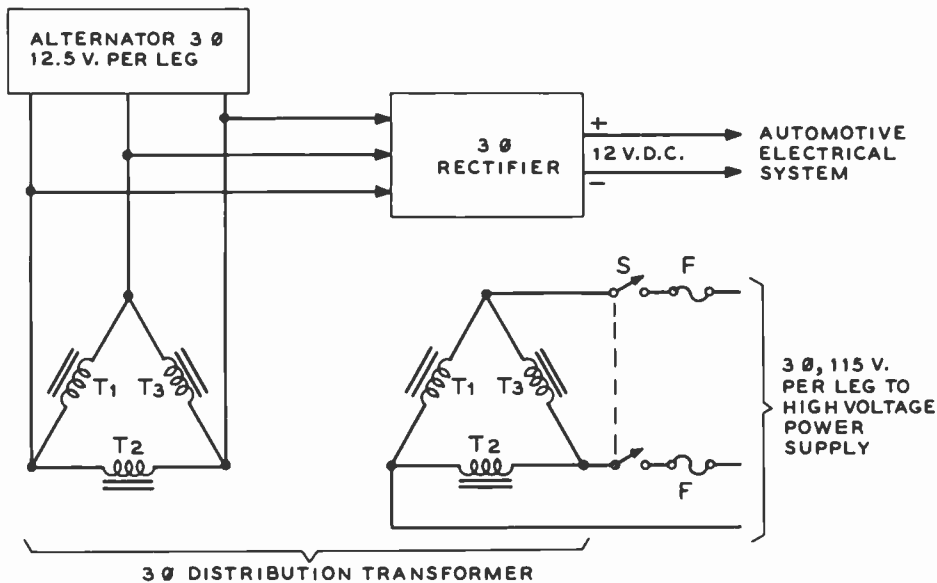

Figure 4

THREE-PHASE MOBILE POWER SYSTEM

Three-phase transformer (T₁) in delta or wye configuration provides 115 volts a.c. for operation of mobile equipment.

thus removing the power to the equipment. If a relay regulator is used, it should be shorted out, or otherwise disabled during mobile operation.

Batteries The voltage available at the terminals of a battery is determined by the chemical composition of the cell. Many types and sizes of batteries are available for portable radio and communication equipment. The inexpensive *carbon-zinc* cell provides a nominal 1.5 volts and, unused, will hold a charge for about a year. The current capacity of the cell depends on the physical size of the electrodes and the composition of the electrolyte. A battery may be made up of a number of cells connected in series, providing good life under intermittent service.

Next to the carbon-zinc cell, the most commonly used unit is the *alkaline cell* (1.2 volts) which has about twice the total energy capacity per unit size as compared to the carbon-zinc cell. This cell is capable of a high discharge rate over an extended



Figure 5

THREE-PHASE DELTA-WYE DISTRIBUTION TRANSFORMER

Tranex 4-1852 transformer provides 115 volts from nominal 12-volt source at 1000 watts average power. (Available from KenPierce Co., Box 877 Palo Alto, Calif. 94302)

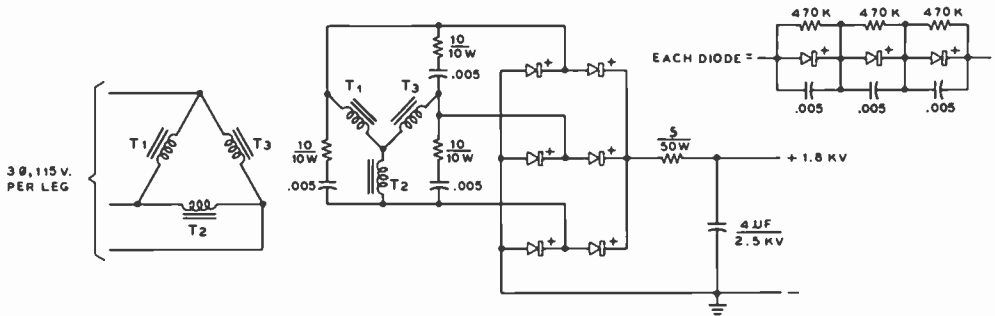

Figure 6

THREE-PHASE-MOBILE KILOWATT SUPPLY

Three-phase power from a system such as shown in figure 3 may be used to provide high voltage for mobile transmitting equipment. For 1800 volts, transformers T_1 , T_2 , and T_3 are 115-volt primary, 830-volt secondary (Stancor PC-8301). For 2400 volts, T_1 , T_2 , and T_3 are 115-volt primary, 1030-volt secondary (Stancor PC-8302). Three type 1N1697 or 1N4005 diodes are used in each stack.

period of time and provides longer life in continuous service than does the carbon-zinc cell.

The mercury cell (1.34 volts) is more expensive than the previously mentioned cells, but it has an extremely long working life. In addition, the mercury cell maintains full rated voltage until just before expiration; then the voltage drops sharply. Shelf life of the mercury cell is excellent and it may be stored for long periods of time.

These three types of batteries may be recharged to some extent by reversing the chemical action by application of a reverse current to the cell. For best results, the current should be low and should have a small a-c component to provide a more even re-deposit of material on the negative electrode. Recharged cells have an uncertain operating life, and the recharging cycle may vary from cell to cell.

The nickel-cadmium (Nicad) cell (1.25 volts) is the most expensive cell in terms of initial costs, but it may be recharged at a slow rate a number of times in reliable cycles of operation.

The wet cell, (lead-acid) storage battery is in near-universal use in automotive equipment. The cell delivers about 2.1 volts and is rechargeable. The lead-acid cell is made of coated lead plates immersed in a solution of sulphuric acid and water. The acid content of the dielectric varies with the state of charge, which may be determined by mea-

asuring the specific gravity of the electrolyte. Generally speaking, a hydrometer reading of 1.27 indicates a fully charged cell, whereas a reading of 1.15 or below indicates the cell is in need of charging. The wet cell may be fast-charged as high as 40 amperes for a 12-volt battery, provided that care is taken to let escaping gases free themselves and provided that electrolyte temperature is held below 125° Fahrenheit.

25-3 Transistor Supplies

The vibrator-type of mobile supply achieves an over-all efficiency in the neighborhood of 70%. The vibrator may be thought of as a mechanical switch reversing the polarity of the primary source at a repetition rate of 120 transfers per second. The switch is actuated by a magnetic coil and breaker circuit requiring appreciable power which must be supplied by the primary source.

One of the principal applications of the transistor is in switching circuits. The transistor may be switched from an "off" condition to an "on" condition with but the application of a minute exciting signal. When the transistor is nonconductive it may be considered to be an open circuit. When it is in a conductive state, the internal resistance is very low. Two transistors properly connected, therefore, can replace

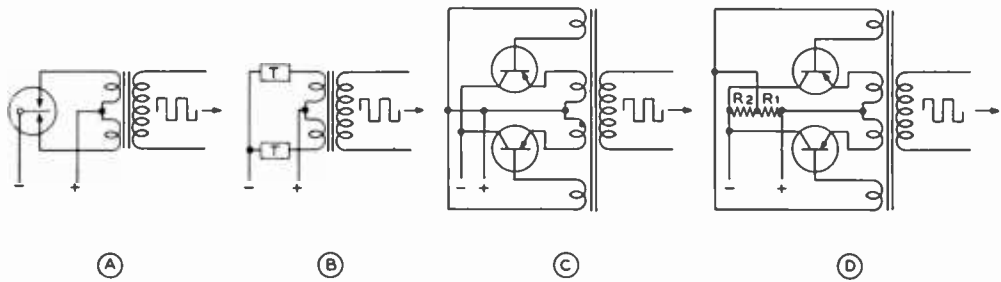

Figure 7

TRANSISTORS CAN REPLACE VIBRATOR IN MOBILE POWER SUPPLY SYSTEM

A—Typical vibrator circuit.

B—Vibrator can be represented by two single-pole single-throw switches, or transistors.

C—Push-pull square-wave "oscillator" is driven by special feedback windings on power transformer.

D—Addition of bias in base-emitter circuit results in oscillator capable of starting under full load.

the single-pole, double-throw mechanical switch representing the vibrator. The transistor switching action is many times faster than that of the mechanical vibrator and the transistor can switch an appreciable amount of power. Efficiencies in the neighborhood of 95 percent can be obtained with 28-volt primary-type transistor power supplies, permitting great savings in primary power over conventional vibrators and dynamotors.

Transistor Operation The transistor operation resembles a magnetically coupled multivibrator, or an audio-frequency push-pull square-wave oscillator (figure 7C). A special feedback winding on the power transformer provides 180-degree phase-shift voltage necessary to maintain oscillation. In this application the transistors are operated as on-off switches; i.e., they are either completing the circuit or opening it. The oscillator output voltage is a square wave having a frequency that is dependent on the driving voltage, the primary inductance of the power transformer, and the peak collector current drawn by the conducting transistor. Changes in transformer turns, core area, core material, and feedback turns ratio have an effect on the frequency of oscillation. Frequencies in common use are in the range of 120 Hz to 3500 Hz.

The power consumed by the transistors is relatively independent of load. Loading

the oscillator causes an increase in input current that is sufficient to supply the required power to the load and the additional losses in the transformer windings. Thus, the over-all efficiency actually increases with load and is greatest at the heaviest load the oscillator will supply. A result of this is that an increase in load produces very little extra heating of the transistors. This feature means that it is impossible to burn out the transistors in the event of a shorted load since the switching action merely stops.

Transistor Power Rating The power capability of the transistor is limited by the amount of heat created by the current flow through the internal resistance of the transistor. When the transistor is conducting, the internal resistance is extremely low and little heat is generated by current flow. Conversely, when the transistor is in a cut-off condition the internal resistance is very high and the current flow is extremely small. Thus, in both the "on" and "off" conditions the transistor dissipates a minimum of power. The important portion of the operating cycle is that portion when the actual switching from one transistor to the other occurs, as this is the time during which the transistor may be passing through the region of high dissipation. The greater the rate of switching, in general, the faster will be the rise time of the square wave (figure 8) and the lower will be the inter-

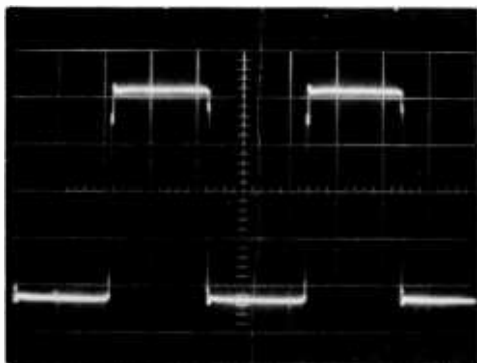

Figure 8

EMITTER-COLLECTOR WAVEFORM OF SWITCHING CIRCUIT

Square waveshape produces almost ideal switching action. Small 2-volt "spike" on leading edge of pulses may be reduced by proper transformer design. Pulse length is about 1000 microseconds and rise time is 10 microseconds.

nal losses of the transistor. The average transistor can switch about eight times the power rating of class-A operation of the unit. Two switching transistors having 5-watt class-A power output rating can therefore switch 80 watts of power when working at optimum switching frequency.

Self-Starting Oscillators The transistor supply shown in figure 7C is impractical because oscillations will not start under load. Base bias of the proper polarity has to be momentarily introduced into the base-emitter circuit before oscillation will start and sustain itself. The addition of a bias resistor (figure 7D) to the circuit results in an oscillator that is capable of starting under full load. R_1 is usually of the order of 10 to 50 ohms while R_2 is adjusted so that approximately 100 milliamperes flow through the circuit.

The current drawn from the battery by this network flows through R_2 and then divides between R_1 and the input resistances of the two transistors. The current flowing in the emitter-base circuit depends on the value of input resistance. The induced voltage across the feedback winding of the transformer is a square wave of such polarity

that it forward-biases the emitter-base diode of the transistor that is starting to conduct collector current, and reverse-biases the other transistor. The forward-biased transistor will have a very low input impedance, while the input impedance of the reverse-biased transistor will be quite high. Thus, most of the starting current drained from the primary power source will flow in R_1 and the base-emitter circuit of the forward-biased transistor and very little in the other transistor. It can be seen that R_1 must not be too low in comparison to the input resistance of the conducting transistor, or it will shunt too much current from the transistor. When switching takes place, the transformer polarities reverse and the additional current now flows in the base-emitter circuit of the other transistor.

The Power Transformer The power transformer in a transistor-type supply is designed to reach a state of maximum flux density (saturation) at the point of maximum density transistor conductance. When this state is reached the flux density drops to zero and reduces the feedback voltage developed in the base winding to zero. The flux then reverses because there is no conducting transistor to sustain the magnetizing current. This change of flux induces a voltage of the opposite polarity in the transformer. This voltage turns the first transistor off and holds the second transistor on. The transistor instantly reaches a state of maximum conduction, producing a state of saturation in the transformer. This action repeats itself at a very fast rate. Switching time is of the order of 5 to 10 microseconds, and saturation time is perhaps 200 to 2000 microseconds. The collector waveform of a typical transistor supply is shown in figure 8. The rise time of the wave is about 5 microseconds, and the saturation time is 500 microseconds. The small "spike" at the leading edge of the pulse has an amplitude of about 2.5 volts and is a product of switching transients caused by the primary leakage reactance of the transformer. Proper transformer design can reduce this "spike" to a minimum value. An excessively large "spike" can puncture the transistor junction and ruin the unit.

Figure 9

SCHEMATIC, TRANSISTOR POWER SUPPLY FOR 12-VOLT AUTOMOTIVE SYSTEM

T_1 —Transistor power transformer. 12-volt primary, to provide 275 volts at 125 ma. Stancor DCT-1

D_1, D_2 —1N4005 with .01 μ fd and 100K across each diode
Use 6 amp. fuse in +12-volt lead.

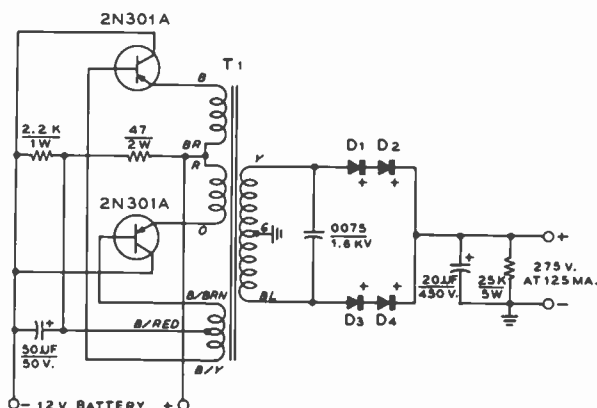

The new *Stancor (Essex) Corp.* series of power transformers designed to work in transistor-type power supplies permits the amateur and experimenter to construct efficient mobile power supplies at a fraction of their former price. Described in this section are two power supplies designed around these efficient transformers. The smaller supply delivers 35 watts (275 volts at 125 milliamperes) and the larger supply delivers 85 watts (500 volts to 125 milliamperes and 250 volts at 50 milliamperes, simultaneously). Both power units operate from a 12-volt primary source.

A 35-Watt Supply The 35-watt power unit uses two inexpensive 2N301A/2N2869 power transistors for the switching elements and four silicon diodes for the high-voltage rectifiers. The complete schematic is shown in figure 9. Because of the relatively high switching frequency only a single 20- μ fd filter capacitor is required to provide pure direct current.

Regulation of the supply is remarkably good. No-load voltage is 310 volts, dropping to 275 volts at maximum current drain of 125 milliamperes.

The complete power package is built on an aluminum chassis-box measuring $5\frac{1}{4}$ " \times 3" \times 2". Paint is removed from the center portion of the box to form a simple heat sink for the transistors. The box therefore conducts heat away from the collector elements of the transistors. The collector of the transistor is the metal case terminal and in this circuit is returned to the nega-

tive terminal of the primary supply. If the negative of the automobile battery is grounded to the frame of the car the case of the transistor may be directly grounded to the unpainted area of the chassis. If the positive terminal of the car battery is grounded it is necessary to electrically insulate the transistor from the aluminum chassis, yet at the same time permit a low *thermal* barrier to exist between the transistor case and the power-supply chassis. A simple method of accomplishing this is to insert a thin mica sheet between the transistor and the chassis. *Two-mil* (0.002") mica washers for transistors are available at many large radio supply houses. The mica is placed between the transistor and the chassis deck, and fiber washers are placed under the retaining nuts holding the transistors in place. When the transistors are mounted in place, measure the collector-to-ground resistance with an ohmmeter. It should be 100 megohms or higher in dry air. After the mounting is completed, spray the transistor and the bare chassis section with plastic *Krylon* to retard oxidation. Several manufacturers produce anodized aluminum washers that serve as mounting insulators. These may be used in place of the mica washers, if desired.

An 85-Watt Supply Figure 10 shows the schematic of a dual-voltage transistor mobile power supply. A bridge rectifier permits the choice of either 250 volts or 500 volts, or a combination of both at a total current drain that limits the

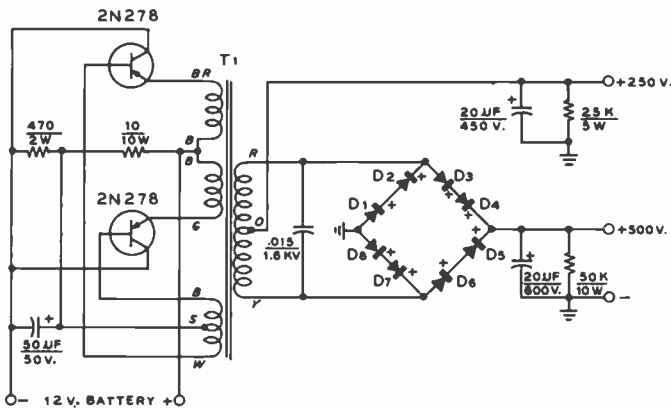

Figure 10
SCHEMATIC,
85-WATT
TRANSISTOR
POWER SUPPLY
FOR 12-VOLT
AUTOMOTIVE
SYSTEM

T₁—Transistor power transformer. 12-volt primary to provide 275 volts at 125 ma. Stancor DCT-2.
D₁-D₈—1N4005 with .01 µfd and 100K across each diode.

secondary power to 85 watts. Thus, 500 volts at 170 milliamperes may be drawn, with correspondingly less current as additional power is drawn from the 250-volt tap.

The supply is built on an aluminum box chassis measuring 7" × 5" × 3", the layout closely following that of the 35-watt supply. *Motorola* 2N278 or *RCA* SK3012 transistors are used as the switching elements and eight silicon diodes form the high-voltage bridge rectifier.

The transistors are affixed to the chassis in conjunction with a homemade aluminum heat sink formed from two pieces of aluminum sheet bent into channels, as shown in figure 11. Silicon grease is spread thinly between the transistors, heat sinks, and the chassis to permit better heat transfer between the various components of the assembly.

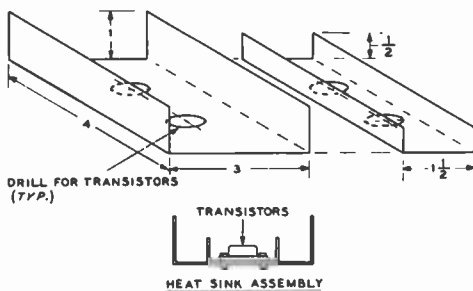

Figure 11

HOMEMADE HEAT SINK FOR POWER TRANSISTOR

A D-C to A-C Inverter For the Car or Boat

Radio and electrical equipment of all kinds up to about 200 watts intermittent power consumption may be run from this compact d-c to a-c power inverter. Designed for use with 12-volt automotive systems, the inverter provides a nominal 115-volt, 60-Hz square-wave output, suitable for transformer-powered equipment, lights, or motors.

The inverter construction is straightforward, and assembly is on an aluminum chassis measuring 8" × 6" × 2". A standard heat sink for the transistors is specified, however, the sink shown in figure 11 may be used. A grounded-collector circuit is

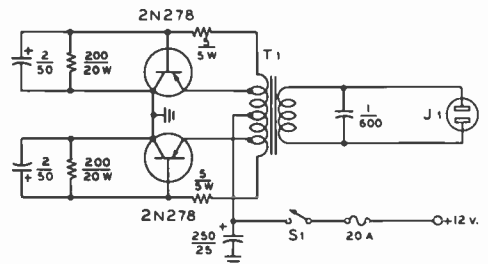

Figure 12

D-C TO A-C INVERTER FOR THE CAR

T₁—Inverter transformer. 12-volt d-c, tapped primary, 115-volt a-c, tapped secondary (*Triad* TY-75A)

Line Filter—*J. W. Miller* 5521 choke, 4 µH at 20 amperes, bypassed with 0.1-µfd capacitors on each side (12-volt circuit). *J. W. Miller* 7818 (115-volt circuit)

Heat Sink—*Wakelield* NC 623A for each transistor

used (negative ground) so the transistors need not be insulated from the heat sink or chassis. Silicon grease should be placed between the transistor, sink sections, and chassis to ensure good thermal conductivity between the units. The low-voltage primary circuit should be wired with heavy-duty flexible line cord, or stranded #12 hookup wire.

This supply is designed to start under full load, and should be turned on loaded, since unloaded operation (especially starting and stopping) may give rise to transients which may endanger the transistors.

The supply is capable of 100 watts continuous power and about twice this amount in intermittent service. Because of the square-wave output, additional line filtering may be necessary in the power line to the equipment, and a suitable line filter is tabulated in the parts list of figure 12.

25-4 Antennas for Mobile Work

Auxiliary Antenna Trimmer One modification of the auto receiver which may or may not be desirable depending on the circumstances is the addition of an auxiliary antenna trimmer capacitor. If the converter uses an untuned output circuit and the antenna trimmer on the auto set is peaked with the converter cut in, then it is quite likely that the trimmer adjustment will not be optimum for broadcast-band reception when the converter is cut out. For reception of strong broadcast-band signals this usually will not be serious, but where reception of weak broadcast signals is desired the loss in gain often cannot be tolerated, especially in view of the fact that the additional length of antenna cable required for the converter installation tends to reduce the strength of broadcast-band signals.

The difficulty can be circumvented by incorporation of an auxiliary antenna trimmer connected from the "hot" antenna lead on the auto receiver to ground, with a switch in series for cutting it in or out. The auxiliary trimmer should have a range of about 3 to 50 pf, and may be of the inexpensive compression mica type.

With the trimmer cut out and the converter turned off (bypassed by the "in-out" switch), peak the regular antenna trimmer on the auto set at about 1400 kHz. Then turn on the converter, with the receiver tuned to 1500 kHz, switch in the auxiliary trimmer, and peak this trimmer for maximum background noise. The auxiliary trimmer then can be left switched in at all times except when receiving very weak broadcast-band signals.

Some auto sets employ a high-Q high-impedance input circuit which is very critical as to antenna capacitance. Unless the shunt capacitance of the antenna (including cable) approximates that of the an-



Figure 13

A CENTER-LOADED 80-METER WHIP USING AIR-WOUND COIL MAY BE USED WITH HIGH-POWERED TRANSMITTERS

An anti-corona loop is placed at the top of the whip to reduce loss of power and burning of tip of antenna. Number of turns in coil is critical and adjustable, high-Q coil is recommended. Whip may be used over frequency range of about 15 kHz without retuning.

tenna installation for which the set was designed, the antenna trimmer on the auto set cannot be made to hit resonance with the converter cut out. This is particularly true when a long antenna cable is used to reach a whip mounted at the rear of the car. Usually the condition can be corrected by unsoldering the internal connection to the antenna terminal connector on the auto set and inserting in series a 100-pf mica capacitor. Alternatively an adjustable trimmer covering at least 50 to 150 pf may be substituted for the 100-pf fixed capacitor.

10-Meter Mobile Antennas

The most popular mobile antenna for 10-meter operation is a rear-mounted whip approximately 8 feet long, fed with coaxial line. This is a highly satisfactory antenna, but a few remarks are in order on the subject of feed and coupling systems.

The feed-point resistance of a resonant quarter-wave rear-mounted whip is approximately 20 to 25 ohms. While the standing-wave ratio when using 50-ohm coaxial line will not be much greater than 2 to 1, it is nevertheless desirable to make the line to the transmitter exactly odd multiples of one-quarter wavelength long electrically at the center of the band. This procedure will minimize variations in loading over the band.

A more effective radiator and a better line match may be obtained by making the whip approximately 10½ feet long and feeding it with 75-ohm coax (such as RG-11/U) via a series capacitor, as shown in figure 14. The relay and series capacitor are mounted inside the trunk, as close to the antenna feedthrough or base-mount insulator as possible. The 10½-foot length applies to the over-all length from the tip of the whip to the point where the lead-in passes through the car body. The leads inside the car (connecting the coaxial cable, relay, series capacitor and antenna lead) should be as short as possible. The outer conductor of both coaxial cables should be grounded to the car body at the relay end with short, heavy conductors.

A 100-pf midget variable capacitor is suitable for C_1 . The optimum setting for lowest SWR at the transmitter should be determined experimentally at the center of

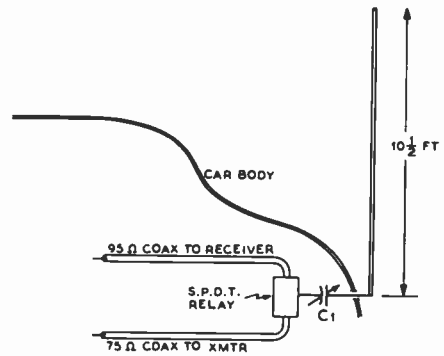

Figure 14

5/16-WAVE WHIP RADIATOR FOR 10 METERS

If a whip antenna is made slightly longer than one-quarter wave it acts as a slightly better radiator than the usual quarter-wave whip, and it can provide a better match to the antenna transmission line if the reactance is tuned out by a series capacitor close to the base of the antenna. Capacitor C_1 may be a 100-pf midget variable.

the band. This setting then will be satisfactory over the whole band.

If an all-band center-loaded mobile antenna is used, the loading coil at the center of the antenna may be shorted out for operation of the antenna on the 10-meter band. The usual type of center-loaded mobile antenna will be between 9 and 11 feet long, including the center-loading inductance

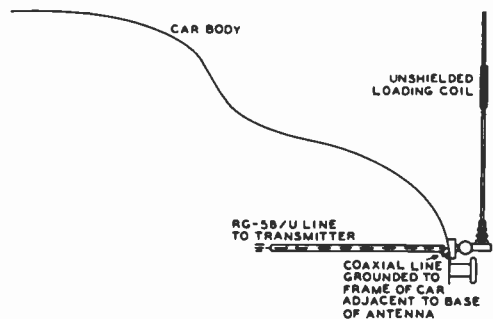

Figure 15

THE CENTER-LOADED WHIP ANTENNA

The center-loaded whip antenna, when provided with a tapped loading coil or a series of coils, may be used over a wide frequency range. The loading coil may be shorted for use of the antenna on the 10-meter band.

which is shorted out. Hence such an antenna may be shortened to an electrical quarter wave for the 10-meter band by using a series capacitor as just discussed. If a pi network is used in the plate circuit of the output stage of the mobile transmitter, any reactance presented at the antenna terminals of the transmitter by the antenna may be tuned out with the pi network.

The All-Band Center-Loaded Mobile Antenna The great majority of mobile operation on the 14-MHz band and below is with center-loaded whip antennas. These antennas use an insulated bumper or body mount, with provision for coaxial feed from the base of the antenna to the transmitter, as shown in figure 15.

The center-loaded whip antenna must be tuned to obtain optimum operation on the desired frequency of operation. These antennas will operate at maximum efficiency over a range of perhaps 20 kHz on the 75-meter band, covering a somewhat wider range on the 40-meter band, and covering the whole 20-meter phone band. The procedure for tuning the antenna is as follows:

The antenna is installed, fully assembled, with a coaxial lead of RG-58/U from the base of the antenna to the place where the transmitter is installed. The rear deck of the car should be closed, and the car should be parked in a location as clear as possible of trees, buildings, and overhead power lines. Objects within 15 or 20 feet of the antenna can exert a considerable detuning effect on the antenna system due to its relatively high operating Q . The end of the coaxial cable which will plug into the transmitter is terminated in a link of 3 or 4 turns of wire. This link is then coupled to a grid-dip meter and the resonant frequency of the antenna determined by noting the frequency at which the grid current fluctuates. The coils furnished with the antennas normally are too large for the usual operating frequency, since it is much easier to remove turns than to add them. Turns then are removed, *one at a time*, until the antenna resonates at the desired frequency. If too many turns have been removed, a length of wire may be spliced on and soldered. Then, with a length of insulating tubing slipped over the soldered

joint, turns may be added to lower the resonant frequency. Or, if the tapped type of coil is used, taps are changed until the proper number of turns for the desired operating frequency is found. This procedure is repeated for the different bands of operation.

Loaded Whip Antennas Short vertical antennas have low radiation resistance and high capacitive reactance and it is difficult to couple them to practical transmitter output circuitry without the necessity of resonating the antenna to the operating frequency. Experience and theory have shown that introduction of a loading coil near the center of the whip antenna can simultaneously tune the antenna to resonance and increase the radiation resistance (figure 15). Typically, an unloaded 8-foot whip has a radiation resistance of approximately 0.5 ohm at 3.9 MHz, with a capacitive input reactance of about 2000 ohms. Introduction of a high- Q center-loading coil can increase the radiation resistance to about one ohm and will cancel the large capacitive reactance of the antenna.

Ground loss resistance in the automobile and capacitance of the car body to ground have been measured to be about 10 ohms at 3.9 MHz. These radiation and loss resistances, plus the loss resistance of a typical loading coil may bring the input impedance of a typical 80-meter center-loaded whip to about 25 to 30 ohms at the resonant frequency. Over-all radiation efficiency is about five to ten percent and operational bandwidth (for a 3/1 SWR on the transmission line) is about 25 kHz when the antenna is properly matched.

The relatively low efficiency of the loaded whip antenna at the lower frequencies indicates that attention must be paid to all details of the antenna installation. The loading coil must be of the highest possible Q and all joints in the antenna system must be low resistance. To properly match the 25-ohm antenna load to a typical 50-ohm transmission line, the matching system of figure 16 may be used. The loaded whip antenna forms a portion of a network whose input impedance over a small frequency range is close to 50 ohms. The antenna is made a part of an equivalent parallel-reso-

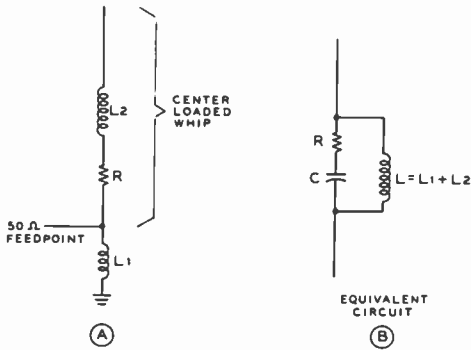

Figure 16

CENTER-LOADED WHIP ANTENNA

A—Center-loaded whip represents large loss resistance (R) which is inverse function of coil Q . High- Q coil (300 or better) provides minimum losses consistent with practical coil design. **B**—Equivalent circuit provides impedance match between whip antenna and 50-ohm feedpoint.

nant circuit in which the radiation resistance appears in series with the reactive branch of the circuit. The input impedance of such a circuit varies nearly inversely with respect to the radiation resistance of the antenna, thus the very low radiation resistance of the whip antenna may be transformed to a larger value which will match the impedance of the transmission line.

The radiation resistance of the whip antenna can be made to appear as a capacitive reactance at the feed point by shortening the antenna. In this case, this is done by slightly reducing the inductance of the center-loading coil. The inductive portion of the tuned network (L_1) consists of a small coil placed across the terminals of the antenna as shown in figure 16A. The LC ratio of antenna and matching coil determine the transformation ratio of the network when the LC product is parallel resonant at the operating frequency of the antenna.

In order to conveniently adjust this matching system, the radiation resistance of the loaded whip antenna should be known, otherwise it may be necessary to try various combinations of matching inductance and loading coil before a satisfactory value of resonant frequency SWR on the feedline is achieved. Methods of measuring the radia-

tion resistance of the antenna are discussed in Chapter 31 of this Handbook.

Construction of a high- Q center-loading coil from available coil stock is shown in figure 17.

An SWR Meter for Mobile Use This simple reflectometer is designed to be used with mobile equipment over the 3- to 30-MHz range at power levels up to 500 watts. It may be placed in the 50-ohm coaxial transmission line to the antenna and mounted under the dash of the automobile to provide a constant check of transmitter power output and antenna operation. It is also useful for tuneup purposes, since the transmitter stages may be adjusted for maximum forward-power reading of the instrument. The circuit is bidirectional; that is, either terminal may be used for either input or output connection.

The SWR meter is constructed in an aluminum utility box measuring 4" \times 4" \times 2" and the circuit is shown in figure 19. The heart of the device is a 4 $\frac{3}{4}$ " long pickup line made of the inner conductor of a length of RG-58A/U coaxial line and a piece of $\frac{1}{4}$ -inch copper tubing, which makes a close slip fit over the polyethylene inner insulation of the line.

To assemble the pickup line, the outer jacket and braid are removed from a length of coaxial line. Before the line is passed within the tubing, the insulation is cut and removed at the center point, which is tinned. A small hole is drilled at the center of the copper-tubing section so that a connection may be made to the inner line. The line is passed through the tubing, and one lead of a 51-ohm, $\frac{1}{2}$ -watt composition resistor is soldered to the line at this point. The pickup line is then bent into a semicircle and the ends of the tubing are affixed to the coaxial connectors, as shown in figure 20.

Sensitivity of the SWR meter is controlled by the variable resistance in series with the meter. To check the instrument, power is fed through it to a matching dummy load and the meter switch set to read forward power. On reversal of the switch, the meter will read reflected power. In the case of a good load match, the reflected reading will be near zero, increasing in value with the degree of mismatch of the load.

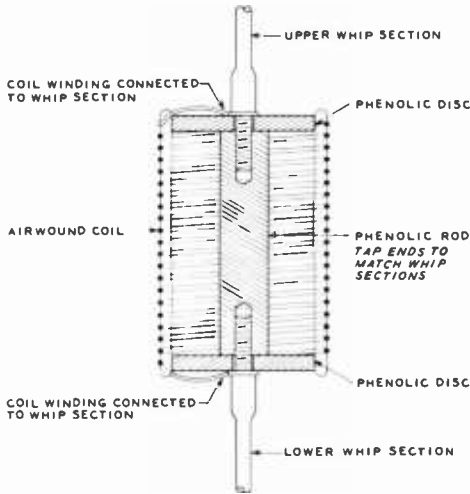
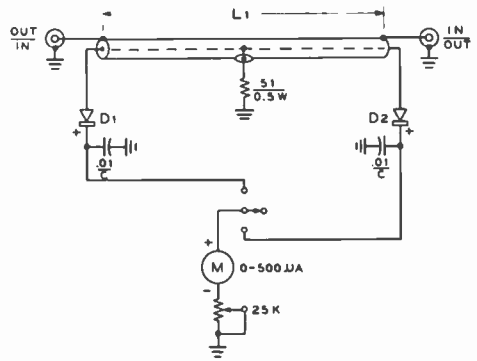

Figure 17

HIGH-Q MOBILE LOADING COIL

Efficient loading coil is assembled from section of air-wound coil stock (Air-Dux or B-W). 2 1/2" diam coil is recommended. Approximate inductance for various bands, when used in center of 8-foot whip is: 160 meters, 700 μ H; 80 meters, 150 μ H; 40 meters, 40 μ H; 20 meters, 9 μ H; 15 meters, 2.5 μ H. Complete antenna is grid-dipped to operating frequency and number of turns in coil adjusted for proper resonance.



D₁, D₂—1N34A
 L₁—See text
 M—0-500 μ A, d-c, Simpson 1212

Figure 19

SCHEMATIC, MINI-SWR METER

25-5 Construction of Mobile Equipment

The following measures are recommended for the construction of mobile equipment, either transmitting or receiving, to ensure trouble-free operation over long periods:

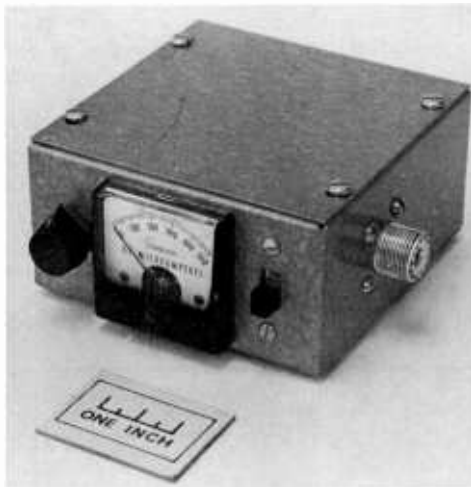

Figure 18

MINI-SWR METER FOR MOBILE EQUIPMENT

Inexpensive reflectometer is built in 4" X 4" X 2" aluminum utility box and may be used over 3- to 30-MHz range at power levels up to 500 watts or so.

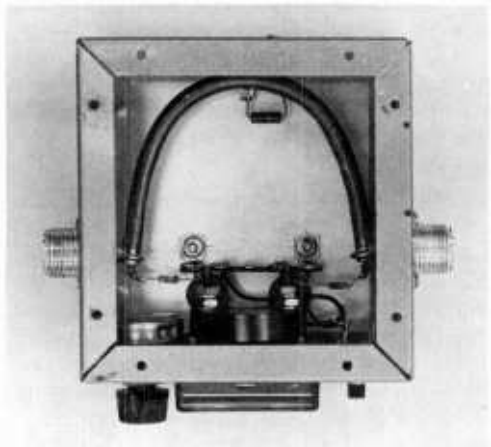

Figure 20

INTERIOR, MINI-SWR METER

Pickup line is bent in semicircle and tubing is soldered to loops of wire which connect to center pin of SO-239 coaxial receptacles. Center conductor of line is attached to diodes D₁, D₂.

Use only a stiff, heavy chassis unless the chassis is quite small.

Use lock washers or lock nuts when mounting components by means of screws.

Use stranded hookup wire except where r-f considerations make it inadvisable (such as for instance the plate tank circuit leads in a vhf amplifier). Lace and tie leads wherever necessary to keep them from vibrating or flopping around.

Unless provided with gear drive, tuning capacitors in the large sizes will require a rotor lock.

The larger-size carbon resistors and mica capacitors should not be supported from tube socket pins, particularly from miniature sockets. Use tie points and keep the resistor and capacitor "pigtailed" short.

Generally speaking, rubber shock mounts are unnecessary or even undesirable with passenger car installations, or at least with full-size passenger cars. The springing is sufficiently "soft" that well constructed radio equipment can be bolted directly to the vehicle without damage from shock or vibration. Unless shock mounting is properly engineered as to the stiffness and placement of the shock mounts, mechanical-resonance "amplification" effects may actually cause the equipment to be shaken more than if the equipment were bolted directly to the vehicle.

To facilitate servicing of mobile equipment, all interconnecting cables between units should be provided with separable connectors on at least one end.

Control Circuits The send-receive control circuits of a mobile installation are dictated by the design of the equipment, and therefore will be left to the ingenuity of the reader. However, a few generalizations and suggestions are in order.

Do not attempt to control too many relays, particularly heavy-duty relays with large coils, by means of an ordinary push-to-talk switch on a microphone. These contacts are not designed for heavy work, and the inductive "kick" will cause more arcing than the contacts on the microphone switch are designed to handle. It is better to actuate a single relay with the push-to-talk switch and then control all other relays, including the heavy-duty contactor for the

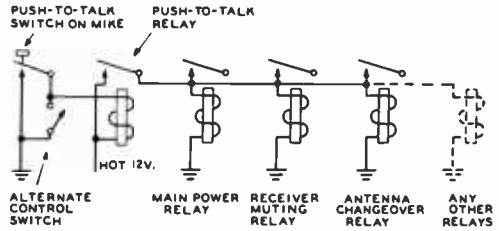

Figure 21

RELAY CONTROL CIRCUIT

Simplified schematic of the recommended relay control circuit for mobile transmitters. The relatively small push-to-talk relay is controlled by the button on the microphone or the communications switch. Then one of the contacts on this relay controls the other relays of the transmitter; one side of the coil of all the additional relays controlled should be grounded.

transistor power pack with this relay.

A recommended general control circuit, where one side of the main control relay is connected to the hot 12-volt circuit, but all other relays have one side connected to the ground, is illustrated in figure 21.

When purchasing relays keep in mind that the current rating of the contacts is not a fixed value, but depends on (1) the voltage, (2) whether it is a.c. or d.c., and (3) whether the circuit is purely resistive or is inductive. If in doubt, refer to the manufacturer's recommendations. Also keep in mind that a dynamotor (if you use one) presents almost a dead short until the armature starts turning, and the starting relay should be rated at considerably more than the normal dynamotor current.

Microphones and Circuits The standardized connections for a majority of hand-held microphones provided with

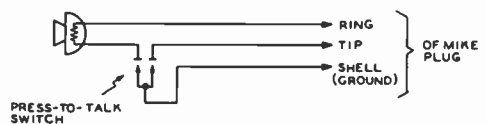

Figure 22

STANDARD CONNECTIONS FOR THE PUSH-TO-TALK SWITCH ON A HAND-HELD SINGLE-BUTTON CARBON MICROPHONE

push-to-talk switch are shown in figure 22.

There is an increasing tendency among mobile operators toward the use of microphones having better frequency and distortion characteristics than the single-button carbon type. The high-impedance *dynamic* type is probably the most popular with the *ceramic-crystal* type next in popularity. The conventional crystal type is not suitable for mobile use since the crystal unit will be destroyed by the high temperatures which can be reached in a closed car parked in the sun in the summer time.

The use of low-level microphones in mobile service requires careful attention to the elimination of common-ground circuits in the microphone lead. The ground connection for the shielded cable which runs from the transmitter to the microphone should be made at only one point, preferably directly adjacent to the input of the first tube or transistor in the speech amplifier. The use of a low-level microphone usually will require the addition of two speech stages, but these stages will take only a milliamperere or two of current.

25-6 Vehicular Noise Suppression

Satisfactory reception on frequencies above the broadcast band usually requires greater attention to noise-suppression measures. The required measures vary with the particular vehicle and the frequency range involved.

Most of the various types of noise that are present in a vehicle may be broken down into the following main categories:

- (1) Ignition noise.
- (2) Wheel static (tire static, brake static, and intermittent ground via front wheel bearings).
- (3) "Hash" from voltage-regulator contacts.
- (4) "Whine" from generator commutator segment make and break.
- (5) Static from scraping connections between various parts of the car.

It is best to thoroughly suppress ignition noise in your car, even though ignition noise from passing vehicles make the use

of a noise limiter mandatory. However, the limiter should not be given too much work to do, because at high engine speeds a noisy ignition system will tend to mask weak signals, even though with the limiter working, ignition "pops" may appear to be completely eliminated.

Another reason for good ignition suppression at the source is that strong ignition pulses contain enough energy, when integrated, to block the avc circuit of the receiver, causing the gain to drop whenever the engine is speeded up. Since the avc circuits of the receiver obtain no benefit from a noise clipper, it is important that ignition noise be suppressed enough at the source that the avc circuits will not be affected even when the engine is running at high speed.

Ignition Noise The following procedure should be found adequate for reducing the ignition noise of practically any passenger car to a level which the clipper can handle satisfactorily at any engine speed at any frequency from 500 kHz to 148 MHz. Some of the measures may already have been taken when the auto receiver was installed.

First either install a spark-plug suppressor on each plug, or else substitute resistor plugs. The latter are more effective than suppressors and on some cars ignition noise is reduced to a satisfactory level simply by installing them. However, they may not do an adequate job alone after they have been in use for a while, and it is a good idea to take the following additional measures.

Check all high-tension connections for gaps, particularly the "pinch-fit" terminal connectors widely used. Replace old high-tension wiring that may have become leaky. Complete substitution of the ignition wiring with a commercial shielded ignition system is recommended in case of severe interference.

Check to see if any of the high-tension wiring is cabled with low-tension wiring, or run in the same conduit. If so, reroute the low-tension wiring to provide as much separation as practical.

Bypass to ground the 12-volt wire from the ignition switch at each end with a 0.1- μ fd molded-case paper capacitor in parallel

with a .001- μ fd mica or ceramic, using the shortest possible leads.

Check to see that the hood makes good ground contact to the car body at several points. Special grounding contactors are available for attachment to the hood lacing on cars that otherwise would present a grounding problem.

If the high-tension coil is mounted on the dash, it may be necessary to shield the high-tension wire as far as the bulkhead, unless it already is shielded with armored conduit.

Wheel Static Wheel static is either static electricity generated by rotation of the tires and brake drums, or is noise generated by poor contact between the front wheels and the axles (due to the grease in the bearings). The latter type of noise seldom is caused by the rear wheels, but tire static may of course be generated by all four tires.

Wheel static can be eliminated by insertion of grounding springs under the front hub caps, and by inserting "tire powder" in all inner tubes. Both items are available at radio parts stores and from most auto radio dealers.

Voltage-Regulator "Hash"

Certain voltage regulators generate an objectionable amount of "hash" at the higher frequencies, particularly in the vhf range. A large bypass capacitor will affect the operation of the regulator and possibly damage the points. A small bypass can be used, however, without causing trouble. A 0.001- μ fd mica capacitor placed from the field terminal of the regulator to ground with the shortest possible leads often will produce sufficient improvement. If not, a choke consisting of about 60 turns of No. 18 d.c.c. wound on a $\frac{3}{4}$ -inch form can be added. This should be placed at the regulator terminal, and the 0.001- μ fd bypass placed from the generator side of the choke to ground.

Generator "Whine" Generator "whine" often can be satisfactorily suppressed from 550 kHz to 148 MHz simply by bypassing the armature terminal to

ground with a special "auto-radio" capacitor of 0.25 or 0.5 μ fd in parallel with a 0.001- μ fd mica or ceramic capacitor. The former usually is placed on the generator when an auto radio is installed, but must be augmented by a mica or ceramic capacitor with short leads in order to be effective at the higher frequencies as well as the broadcast band.

When more drastic measures are required, special filters can be obtained which are designed for the purpose. These are recommended for stubborn cases when a wide frequency range is involved. For reception over only a comparatively narrow band of frequencies, such as the 10-meter amateur band, a highly effective filter can be improvised by connecting a resonant choke between the previously described parallel bypass capacitors and the generator armature terminal. This may consist of 11 turns of No. 10 enameled wire wound on a one-inch form and shunted with an adjustable 30-pf trimmer capacitor to permit resonating the combination to the center of the ten-meter band.

When generator "whine" shows up after once being satisfactorily suppressed, the condition of the brushes and commutator should be checked. Unless a bypass capacitor has opened up, excessive "whine" usually indicates that the brushes or commutator are in need of attention in order to prevent damage to the generator.

Body Static Loose linkages in body or frame joints anywhere in the car are potential static producers when the car is in motion, particularly over a rough road. Locating the source of such noise is difficult, and the simplest procedure is to give the car a thorough tightening up in the hope that the offending poor contacts will be caught up by the procedure. The use of braided bonding straps between the various sections of the body of the car also may prove helpful.

Miscellaneous There are several other potential noise sources on a passenger vehicle, but they do not necessarily give trouble and therefore require attention only in some cases.

The heat, oil pressure, and gas gauges can cause a rasping or scraping noise. The gas gauge is the most likely offender. It will cause trouble only when the car is rocked or is in motion. The gauge units and panel indicators should both be bypassed with the 0.1- μ fd paper and 0.001- μ fd mica or ceramic capacitor combination previously described.

At high car speeds under certain atmospheric conditions, corona static may be encountered unless means are taken to prevent it. The receiving-type auto whips which employ a plastic ball tip are so provided in order to minimize this type of noise, which is simply a discharge of the frictional static built up on the car. A whip which ends in a relatively sharp metal point makes an ideal discharge point for the static charge, and will cause corona trouble at a much lower voltage than if the tip were hooded with insulation. A piece of *Vinylite* sleeving slipped over the top portion of the whip and wrapped tightly with heavy thread will prevent this type of static discharge under practically all conditions. An alternative arrangement is to wrap the top portion of the whip with *Scotch* brand electrical tape.

Generally speaking it is undesirable from the standpoint of engine performance to use both spark-plug suppressors *and* a distributor suppressor. Unless the distributor rotor clearance is excessive, noise caused by sparking of the distributor rotor will not be so bad but that it can be handled satisfactorily by a noise limiter. If not, it is preferable to shield the "hot" lead between ignition coil and distributor rather than use a distributor suppressor.

In many cases the control rods, speedometer cable, etc., will pick up high-tension noise under the hood and conduct it up under the dash where it causes trouble. If so, all control rods and cables should be bonded to the fire wall (bulkhead) where they pass through, using a short piece of heavy flexible braid of the type used for shielding.

In some cases it may be necessary to bond the engine to the frame at each rubber engine mount in a similar manner. If a rear-mounted whip is employed, the exhaust tail pipe also should be bonded to the frame if supported by rubber mounts.

Locating Noise Sources Determining the source of certain types of noise is made difficult when several things are contributing to the noise, because elimination of one source often will make little or no apparent difference in the total noise. The following procedure will help to isolate and identify various types of noise.

Ignition noise will be present only when the ignition is on, even though the engine is turning over.

Generator noise will be present when the motor is turning over, regardless of whether the ignition switch is on. Slipping the drive belt off will kill it.

Gauge noise usually will be present only when the ignition switch is on or in the "left" position provided on some cars.

Wheel static, when present, will persist when the car clutch is disengaged and the ignition switch turned off, with the car coasting.

Body noise will be noticeably worse on a bumpy road than on a smooth road, particularly at low speeds.

25-7 A Printed-Circuit SSB Transceiver

This basic filter-type SSB transceiver-exciter is designed for minimum cost and maximum ease in assembly. It is built on a phenolic printed-circuit board* and operates on any one of the 160-, 80-, or 40-meter bands with a PEP input power of 5 watts (figure 23). In conjunction with an external vfo and linear amplifier, this printed-circuit transceiver makes an economical and reliable "first SSB project" for either fixed or mobile service. The transceiver power requirements are 300 volts at 80 ma and 12.6 volts, a.c. or d.c. at 1.8 amperes. The transmit-receive control requires only a single-pole switch, which can be incorporated in a push-to-talk circuit. Other refinements such as VOX and ALC may be added after the unit is completed, if desired.

*A full size drawing of the circuit board and component layout information may be obtained by sending 25 cents to cover the cost of mailing to Editors & Engineers, New Augusta, Indiana 46268.

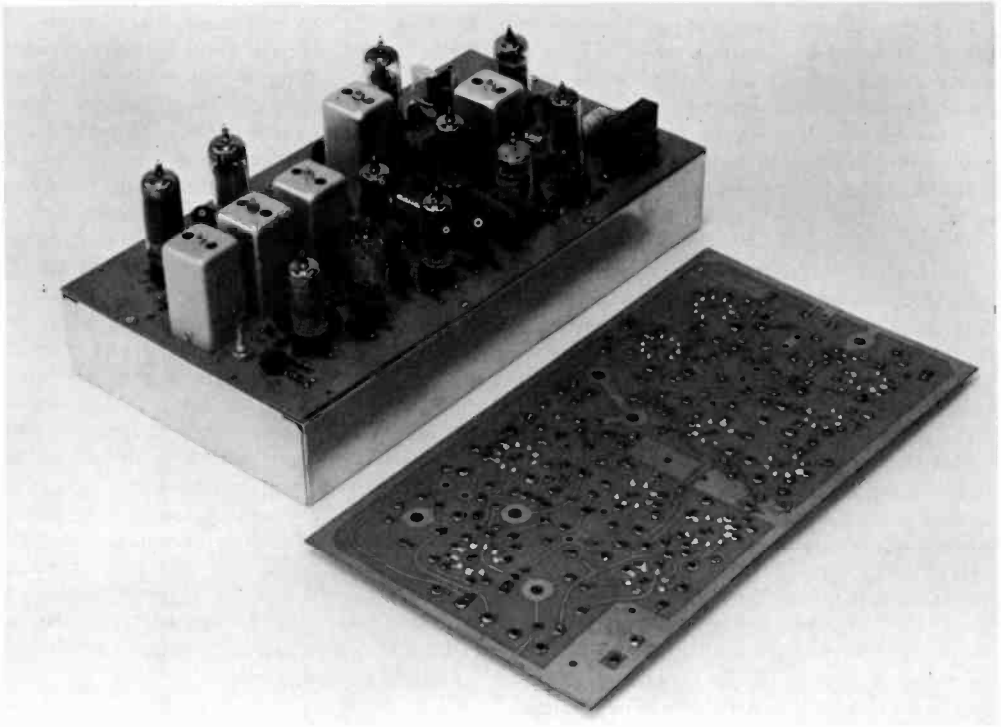

Figure 23

PRINTED-CIRCUIT SSB TRANSCEIVER

Underside of circuit board rests in front of completed exciter. Input circuits and transformers T_1 , T_2 and T_3 are at left, with mechanical filter at center. Output transformer and 6AQ5 audio tube are at right foreground. Circuit board is mounted on inverted aluminum chassis used for dust cover.

Transceiver Circuit A block diagram of the transceiver is shown in figure 24.

Eleven tubes are used, and various r-f and i-f circuits, the mixing oscillators, and the crystal filter are common to transmit and receive modes. Operation may be understood by reference to the schematic diagram of figure 25.

The Receiver Portion—In the receiving mode, the circuit takes the form of a single-conversion superheterodyne having a 455-kHz i-f system. The received SSB signal is resonated in the antenna input circuit (T_1) which is coupled to a 12BA6 remote-cutoff r-f amplifier (V-1). The plate circuit of the 12BA6 is coupled to the receiver mixer via a bifilar transformer (T_2) which is also used in the transmission mode. A 12BE6 (V-2) serves as a receiver

mixer, the input signal being mixed with the local-oscillator signal to produce a 455-kHz intermediate frequency. The oscillator stage is common to both transmit and receive circuits, the exact tuning range depending on the band in use. The external oscillator is coupled into the transceiver via jack J_2 . Oscillator injection voltage is about 4 volts, rms.

The 455-kHz intermediate-frequency signal from the mixer stage is coupled via transformer T_3 to the 12BA6 first i-f stage (V-3). Again, transformer T_3 is also used in the transmit mode. The output of the first i-f amplifier passes through the sideband mechanical filter, FL-1, to a second 12BA6 i-f amplifier (V-4) and then to a diode detector. At this point in the circuit, carrier is injected in the detector from the

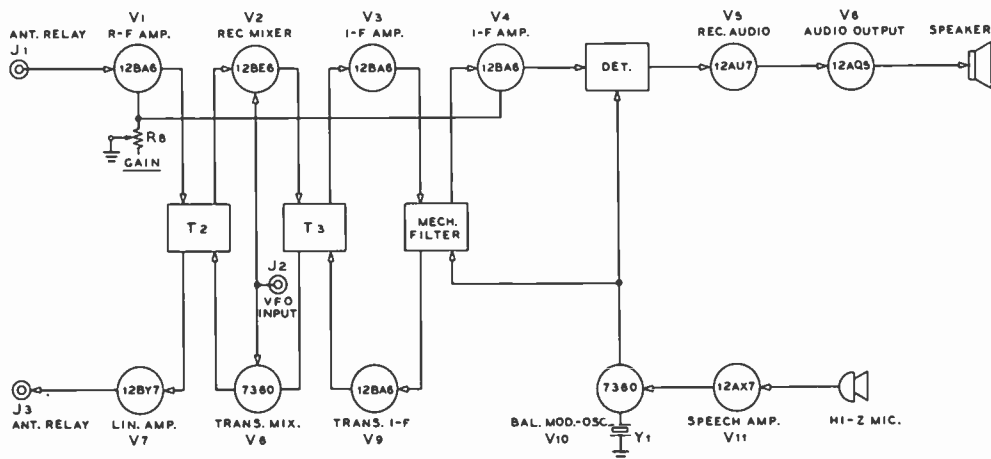

Figure 24

BLOCK DIAGRAM OF PRINTED CIRCUIT TRANSCEIVER

Eleven tubes are used in a multipurpose circuit. Common r-f and i-f systems simplify construction and reduce cost. External vfo tunes both receiving and transmitting sections.

oscillator section of the 7360 oscillator/balanced modulator (V-10). The resulting audio signal is amplified in a 12AU7 double triode (V-5) and the 12AQ5A output stage (V-6), which delivers sufficient audio volume to overcome car and wind noise encountered in mobile work. Receiver volume is controlled by gain potentiometer R_8 . The transceiver is designed to be used with a 4- to 8-ohm external speaker (the speaker of the automobile receiver, for example).

The Transmitter Portion—In the transmitting mode, the circuit takes the form of a single-conversion, mechanical filter SSB exciter, featuring a 7360 beam-deflection mixer and local oscillator. Switching the circuitry from receive to transmit is accomplished by a single switch which transfers the +300-volt supply from the plate and screen circuits of the tubes in the receiver section to the corresponding circuits of the tubes in the transmitter section. No r-f switching is involved, other than the use of an external antenna changeover relay. Both mixing oscillators are common to receive and transmit modes and run at all times, thus helping to reduce short-term frequency drift.

When transmitting, the sideband carrier is generated by the common crystal oscillator (V-10) a portion of the 7360 balanced modulator. The triode portion of the 7360 functions as a "hot-cathode" crystal oscillator, using a crystal whose frequency is placed at the appropriate point on the pass-band slope of the mechanical filter. The deflection portion of the 7360 serves as a balanced modulator, with the audio signal from the 12AX7 speech amplifier (V-11) applied to one deflection plate of the 7360. The resulting double-sideband, suppressed-carrier signal is coupled into the mechanical filter (FL-1) through the balanced mixer transformer (T_5). The mechanical filter suppresses the undesired sideband and the carrier, which is already somewhat attenuated by the balanced modulator. The desired sideband is amplified in the transmitter i-f amplifier stage (V-9) and passed through common i-f transformer T_5 to the 7360 transmitter mixer (V-8) where it is mixed with the conversion oscillator to produce an SSB signal on the same frequency as the signal being received. The SSB signal is further amplified in the 12BY7A linear amplifier stage (V-7). The linear stage de-

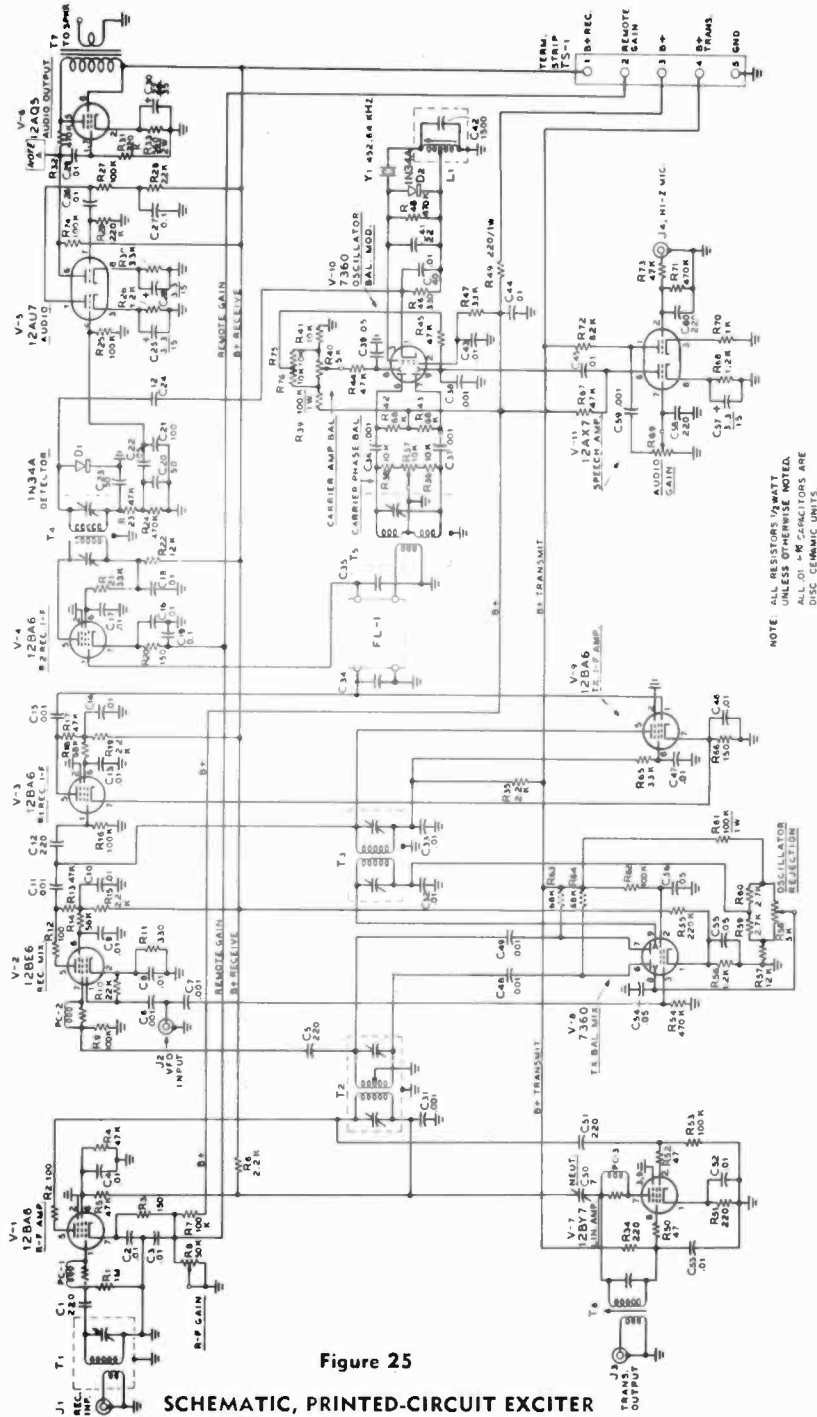

Figure 25

SCHMATIC, PRINTED-CIRCUIT EXCITER

Note: Part numbers correspond to callout diagram of printed-circuit board, see text. Audio ALC may be taken from point A.

PARTS LIST FOR FIGURE 25

- $C_{1,2}$.—See filter specifications
- L_1 .—Approx. 80-100 μ H, adjustable. 105 turns #32e., tap 25 turns from ground, $\frac{3}{8}$ " diam form, powdered-iron slug (J. W. Miller 42A825-CBI)
- T_1 .—See text. (J. W. Miller 66A024-2 form, $\frac{1}{4}$ " diam, powdered-iron [red] slug)
- T_2 .—455-kHz i-f transformer (J. W. Miller 112-C1, modify per text)
- T_3, T_4 .—Same as T_1 , unmodified
- T_5 .—Same as T_1 , modify as per text
- T_6 .—10 k to voice coil. Triad S6-X

- T_7 .—160 meters: 16 μ H, $\frac{1}{2}$ " diam, powdered-iron slug. Resonate with 550 pf (J. W. Miller 43A225-CBI)
- 80 meters: 8 μ H. Resonate with 200 pf (J. W. Miller 43A105-CBI)
- 40 meters: 4 μ H. Resonate with 100 pf (J. W. Miller 42A476-CBI)
- Links: 160 meters, 8 turns; 80 meters, 6 turns, 40 meters, 4 turns
- $PC_{1,2}$.—10 turns #24e. wire on 47-ohm $\frac{1}{2}$ -watt resistor

livers about 5 watts PEP to the antenna through a simple link-coupled output circuit (T_8).

Transceiver Layout and Assembly The major components of the transceiver are assembled on a phenolic circuit board measuring 7" X 13". One side of the board has the copper laminate affixed to it which represents the circuitry and the various components are mounted on the opposite side. The board is designed to fit atop an inverted aluminum

chassis which is used as a combined support and dust cover. Layout of the major components may be seen in the photographs. The parts layout should be studied and understood before any components are mounted on the board. All parts are placed atop the board with the exception of the neutralizing capacitor for the 12BY7, the various potentiometers, and the 12BY7 output circuit.

Once the builder is familiar with the circuit and placement of the components, the various parts may be placed on the board in the following suggested sequence: Tube sockets and crystal socket, potentiometers, resistors and capacitors, diodes, r-f trans-

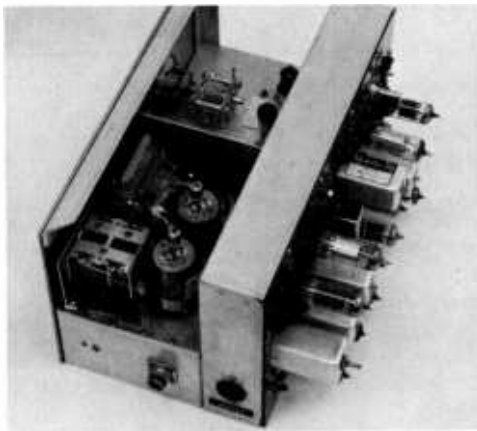
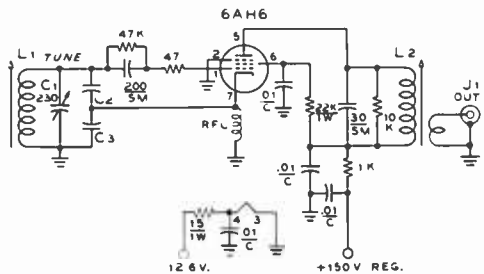

Figure 26

200-WATT PEP PRINTED-CIRCUIT TRANSCEIVER

Transceiver assembly of figure 23 is mounted vertically behind 13" X 5" X 3" aluminum chassis which contains vfo and linear amplifier. Complete transceiver is covered with wraparound shield to protect tubes and components mounted on printed-circuit board. Antenna and power receptacles are on near edge of assembly. 6AH6 and voltage-regulator tubes are in rear compartment, with 6146B linear-amplifier tubes in foreground.



BAND (MHZ)	OSC. FREQ (MHZ)	L1 (μ H)	C2, C3 (μ F)	L2 (μ H)
1.8 - 2.0	2.255 - 2.455	2.5	.003	200
3.8 - 4.0	4.255 - 4.455	1.2	.002	55
7.1 - 7.3	7.655 - 7.755	0.48	.002	15

Figure 27

MOBILE VFO FOR SSB EXCITER

- L_1 .—160 meters (J. W. Miller 42A336-CBI, ceramic, $\frac{3}{8}$ " diam. with powdered-iron slug)
- 80 meters (J. W. Miller 42A336-CBI)
- 40 meters (J. W. Miller 42A336-CBI with turns removed to resonate)
- Note: Affix core with candle wax to prevent vibration after final alignment.
- L_2 .—160 meters (J. W. Miller 21A475-RBI, phenolic, $\frac{3}{8}$ " diam. with powdered-iron slug)
- 80 meters (J. W. Miller 21A475-RBI)
- 40 meters (J. W. Miller 21A155-RBI)

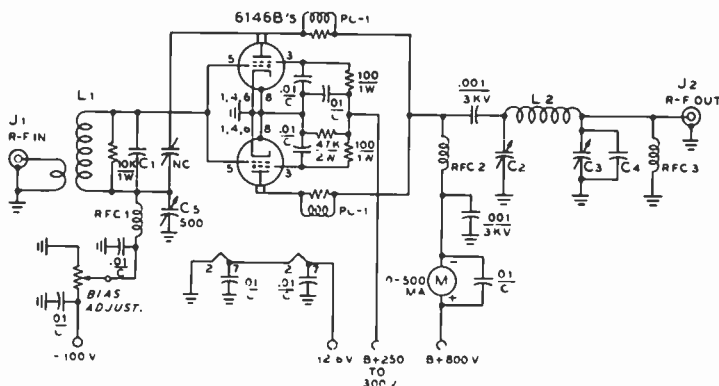

Figure 28
MOBILE LINEAR AMPLIFIER FOR SSB EXCITER

- C_1 —160 meters, 220 pf; 80 meters, 110 pf; 40 meters, 50 pf
 C_2 —160 meters, 500 pf; 80 meters, 250 pf, 40 meters, 125 pf at 1kV
 $C_3 + C_4$ —160 meters, 3500 pf; 80 meters, 1800 pf; 40 meters, 1000 pf. Use 3-gang b-c capacitor plus fixed mica padder
 C_5 —Mica compression trimmer. (J. W. Miller 160-A)
 L_1 —160 meters, 32 μ H (J. W. Miller 42A335-CBI, ceramic, $\frac{3}{8}$ " diam. with powdered iron slug)
 80 meters, 15 μ H (J. W. Miller 42A155-CBI)
 40 meters, 8 μ H (J. W. Miller 42A686-CBI)
 Link windings—160 meters, 8 turns; 80 meters, 6 turns; 40 meters, 4 turns
 NC —2 pf. Aluminum plate 1" X 4" mounted adjacent to 6146B's
 RFC_1 —2.5 μ H, 100 ma. (National R-100)
 RFC_2 —260 μ H. (J. W. Miller RFC 3.5)
 PC —50-ohm, 2 watt composition resistor wound with 5 turns, spaced # 20e. wire
 Note: See figure 30, Chapter 15 for operating data for 6146B tube.

formers, filament wiring, leads for external connections; and finally, the oscillator coil, neutralizing capacitor, crystal filter, and output coil. A 40-watt "pencil soldering iron" should be used to solder the component leads to the copper foil.

When mounting the tube sockets, gently press the prongs through the board with a small screwdriver blade until the socket is snug with the surface of the board. The pins may then be soldered in place. Make sure all of the component leads to a given hole on the board are in place before the connection is soldered. A check mark may be installed to keep track of the numerous components. Potentiometer terminals may be connected to the board with short lengths of wire. The potentiometers are installed on the underside of the board with their shafts available on the top of the board.

The copper foil area around the mechanical filter position is sufficiently large so as to accept either the Collins type Y or K series filter, or other make of 455-kHz filter

of the same approximate size. The board may be drilled to accept the chosen filter, with appropriate changes made in filter connections, according to make and model.

Transceiver Coils Data is given for various transceiver coils in the parts list. Transformers T_2 , T_3 and T_8 are rewound from commercial items (J. W. Miller type 112-C-1 midget 455-kHz i-f transformers measuring $1\frac{1}{8}$ " square and 2" high).

Transformer T_2 —This is a modified i-f transformer of the type specified, or its physical equivalent. The windings are removed from the transformer and a new bifilar winding and primary are substituted. The primary winding consists of 34 turns of #32 enamel wire close-wound. The winding is started about $1/16$ " from the end of the coil form away from the tuning capacitors. To start the windings, punch two closely spaced holes in the form with a needle. Place the holes in line with the

turns of the coil. One coil end may be anchored in these holes by threading the wire through the holes, leaving sufficient wire to make a connection to the tuning capacitor. The winding is placed on the form and two more needle holes are punched in the form to terminate the winding in the same fashion. The leads of the winding are connected to one of the mica compression tuning capacitors on the transformer assembly. Bring out a blue wire (plate) from the capacitor terminal having the coil lead farthest away from the capacitor and a red lead (B-plus) from the other terminal of the capacitor.

The bifilar secondary winding is now started $\frac{1}{8}$ " away from the primary winding. This coil is made up of 17 turns of #32 enamel wire composed of two parallel wires wound side by side (a total of 34 turns). Again, use needle holes to anchor each of the two wires, leaving leads which will be connected later. Wind the two wires smoothly and closely for 17 turns simultaneously and terminate each wire in a pair of needle holes in the coil form. The double winding must now be properly connected to make the necessary bifilar coil. The leads nearest the primary coil are called the *start* leads, and the leads nearest the mica compression capacitors are called the *end* leads. Take one *start* lead of the interlaced coils and one *end* lead of the *opposite* coil. Connect these leads together and to a small solder lug which is slipped over the bolt used to hold the coil assembly in its can. This provides the ground point for the center tap of the bifilar winding. When the transformer is placed on the board, the can and center tap will be grounded. There remains one *start* and one *end* lead which are to be connected to the remaining mica compression trimmer capacitor, one lead going to each terminal of the capacitor. From each terminal, bring out two leads (yellow) for connection to the circuit board. The assembly is now placed in the aluminum can.

Transformer T_5 —This is a standard 455-kHz transformer with a simple modification. The assembly is removed from the shield can and the windings are to be closely coupled. To do this, gently heat the form and winding farthest away from the tuning capacitors until the wax softens. Push the

winding within $\frac{3}{16}$ " of the other winding. The coil will slip easily when warm enough. Check the leads to make sure none are broken by movement of the coil. Reassemble the transformer in its shield can.

Transformer T_5 —This is a standard 455-kHz transformer modified in the following manner: Remove the assembly from the shield can and disconnect all four leads at the mica compression capacitors. Remove and discard black and green leads. Remove 80 turns (about 11' 8") of wire from each winding, leaving enough length for connections. Next, wind an 8-turn link coil of #32 enameled wire between the two coils. Twist the leads of the link together and bring out as a twisted pair of wires. These may be labeled black and white.

Connect one end of the coil nearest the mica tuning capacitors to the opposite end of the second coil and then to a solder lug which is slipped over the stud used to hold the assembly in the shield can. This provides a grounded center tap for the secondary winding. The two free ends of the coils are connected to the free mica tuning capacitor and two connecting leads are brought out, colored red and blue for easy identification.

Testing the Transceiver Additional external wiring must be done to the circuit board before it is ready for test. A wire must be run from the potentiometer R_8 to the junction of R_{20}/C_{19} (near V-4) and then to the remote sensitivity termination point. A remote r-f gain control may be placed from this point to ground, if desired. A second wire must be run from R_7 (near V-1) to the junction of $R_{17}/C_{44}/R_{49}$ (near V-11). Finally, the filament wiring should be placed on the board. Either 6-volt or 12-volt operation may be chosen. For 6-volt operation, the 6-volt counterparts of the 12-volt tubes are used: 6BA6, 6BE6, and 6AQ5. The 12AU7 and 12AX7 have centertapped filaments and may be wired in parallel for 6-volt operation.

Before applying any voltages, check off the wiring and placement of parts to make sure the circuit is in proper shape. Apply the chosen filament voltage and see that all filaments appear normal. An external oscillator, speaker, and 5-watt dummy load are

required. The receiver section should be checked out first as this will bring coil tuning closer for final transmitter tuneup.

Apply 300 volts to the *B+ Receive* and *B+ Continuous* terminals. The receiver section should be operating and tuneable by varying the local-oscillator injection frequency. Peak transformers T_1 , T_2 , T_3 , and T_4 for maximum audio output using a modulated signal from a test generator. The frequency of the injection oscillator may be either 455 kHz above or below the received frequency. Being above or below will dictate which sideband will be received for a given carrier oscillator crystal. Adjustment of oscillator coil L_1 may be peaked for maximum signal while in the receive

condition.

Initial operation of the transmitter section requires removing the voltage from *B+ Receive* and applying it to *B+ Transmit*. As in any SSB exciter, tuneup requires a tone, or carrier signal which may be achieved by unbalancing the balanced modulator. In this case it will be assumed that the modulator is unbalanced by positioning balance potentiometer R_{37} near an extreme clockwise setting. Using the station receiver tuned to the output frequency, transformers T_1 , T_2 , T_3 , and T_5 can be more closely brought into resonance, using maximum S-meter reading of the receiver as indication of resonance. The 455-kHz modulator is now balanced to drop out the car-



Figure 29

200 WATT PEP SIDEBAND TRANSCEIVER FOR 80, 40, AND 20 METERS

Less than a cubic foot in volume, this inexpensive transceiver will fit into today's "compact" automobile. Unit may also be used with auxiliary 115-volt a-c supply for the home station. The major controls on the panel are (l. to r.): sideband switch (S_1), SSB/a-m selector switch (S_2), audio volume (R_3), microphone gain (R_4), carrier injection (S_3), band-selector switch (S_{3-5}), microphone jack (J_1), r-f gain (R_5), meter-selector switch (S_4), antenna loading capacitor (C_{12}), and final amplifier tuning (C_{11}). The main frequency-control dial (C_1) is at top center. Wrap-around, perforated cabinet provides ventilation and acts as TVI shield.

Once adjusted for a particular band, the only tuning required is done with the vfo control. Bandpass coupling allows large excursions in frequency. The vfo tuning mechanism with 100:1 ratio makes sideband tuning a pleasure.

CHART 1.

TRANSCEIVER VOLTAGES
TUBE-SOCKET, D-C VOLTAGE CHART

TUBE	1	2	3	4	5	6	7	8	9
V ₁ -12BA6	0	0	FIL	FIL	260	75	1.25	—	—
V ₂ -12BE6	0	0	FIL	FIL	210	65	0	—	—
V ₃ -12BA6	0	0	FIL	FIL	23	80	1.3	—	—
V ₄ -12BA6	0	0	FIL	FIL	275	120	2.2	—	—
V ₅ -12AU7	75	0	2.75	FIL	FIL	130	0	6	FIL
V ₆ -12AQ5	0	18	FIL	FIL	275	275	0	—	—
V ₇ -12BY7	8	0	0	FIL	FIL	FIL	275	275	0
V ₈ -7360	7	200	0	FIL	FIL	125	125	39	39
V ₉ -12BA6	0	0	FIL	FIL	275	110	2	—	—
V ₁₀ -7360	2	245	7	FIL	FIL	135	135	24	24
V ₁₁ -12AX7	170	0	1.5	FIL	FIL	220	0	1.8	FIL

Note: Input power = 275 volts at 100 ma, gain full on.

rier by adjustment of potentiometers R₃₇ and R₁₀ and the tuning capacitor of transformer T₅. Next, potentiometer R₅₈ should be adjusted to balance out the oscillator injection frequency at the grid of linear amplifier V-7. The last step is to neutralize the 12BY7A linear amplifier. A simple bridge circuit is used, and proper adjustment is described in Chapter 11, Section 6 of this Handbook.

25-8 A 200-Watt 3-Band Sideband Transceiver

A mobile SSB transceiver covering three bands can be built utilizing few more parts than a single-band unit, and without requiring any great increase in size over a single-band model. This compact and inexpensive triband transceiver (figure 29) is designed for 80-, 40-, and 20-meter operation at levels up to 200 watts peak envelope power input. Upper sideband, lower sideband, or amplitude modulation may be transmitted on each band. Push-to-talk circuitry is included and the transceiver may be operated from a six- or twelve-volt d-c power source or from a 115-volt a-c supply. Weighing only a few pounds, the transceiver measures only 10" × 12" × 6½" in size — small enough to fit into "compact" cars!

Circuit Description A block diagram of the transceiver is shown in figure 30. Fourteen tubes and two voltage regulators are used. As practically all mobile operation is done on voice, the tuning range of the transceiver can be limited to the phone segments of the bands used. With such a restricted tuning range, bandpass coupling between low-level r-f stages is practical in both the transmitting and receiving sections of the unit, thus eliminating the need of variable tuning controls for several stages. The variable-frequency oscillator is common to both transmitting and receiving sections and tunes only 350 kHz, which is ample range for the 80-meter band and provides full coverage of the 40- and 20-meter bands. Although several of the tubes in the unit are common to both transmit and receive sections, the receiver r-f section is independent of the transmitter section to make construction easier and to facilitate alignment. The final amplifier tank circuit, however, is used as the antenna input circuit for the receiver to take advantage of the high Q of the circuit and to conserve space. Only two relays are required for receive-transmit changeover and these relays are actuated by the microphone push-to-talk circuit. One miniature relay (RY₂) grounds the grid of the r-f amplifier in the receiver (V₉) for protection

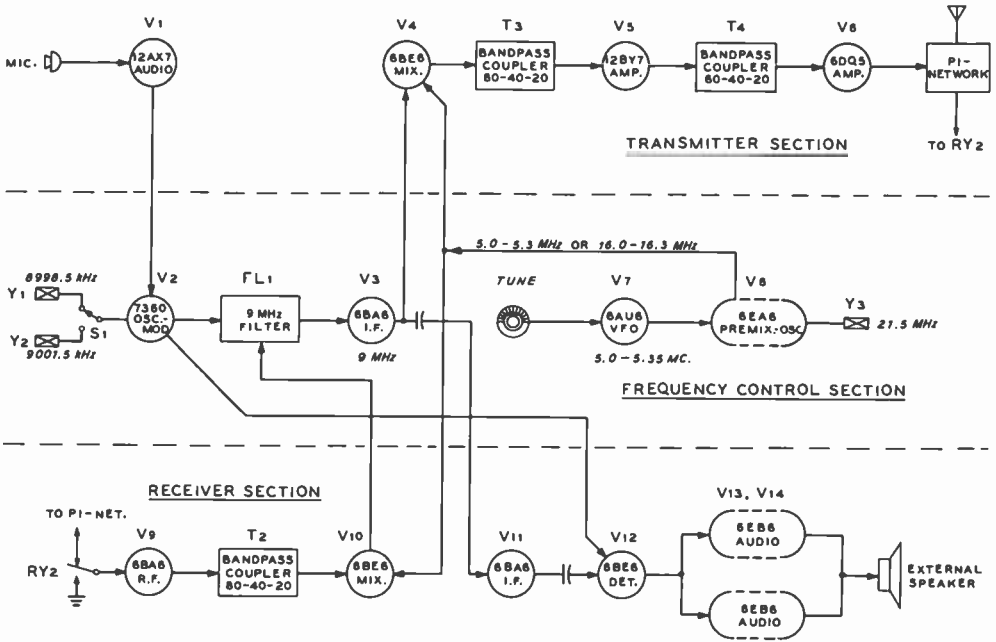

Figure 30

BLOCK DIAGRAM OF TRANSCEIVER

Frequency-control section of unit is common to both receiver and transmitter sections. Beam-deflection type 7360 serves as carrier oscillator and modulator, followed by 9-MHz crystal sideband filter and i-f amplifier stage. Variable-frequency oscillator and mixing oscillator for 7-MHz operation are also common to both sections of transceiver. Transmitter section comprises microphone amplifier and transmitter mixer followed by two linear amplifier stages. Receiver section consists of r-f amplifier and mixer followed by additional i-f stage, product detector, and audio amplifier. Simple push-to-talk circuit switches configuration from transmit to receive.

during transmissions and a second relay (RY₁) switches various voltages between transmit and receive circuits. Full automatic gain control (agc) is incorporated in the receiver, together with an auxiliary r-f gain control. When transmitting, an automatic level control (alc) system reduces flat-topping and serious overload distortion. The single panel meter may be switched to read cathode current of the linear amplifier stage or relative power output at the antenna receptacle.

The transceiver is designed around the McCoy 9-MHz sideband filter, utilizing the sum and difference products created by mixing with a 5-MHz vfo signal to cover the 80- and 20-meter bands. Forty-meter output is obtained by premixing the vfo signal with a 21.5-MHz crystal oscillator to pro-

vide a tuneable 16.5-MHz variable-frequency injection signal. This, mixing in turn with the 9-MHz sideband signal, produces a difference frequency in the 7-MHz range.

The Receiver Portion—The receiver portion of the unit starts with a 6BA6 remote-cutoff r-f amplifier (V₉) bandpass-coupled to a 6BE6 mixer (V₁₀) whose injection grid receives mixing voltage from the common 6AU6 vfo (V₇) via the buffer stage (V₈). The 6EA8 buffer functions as a pre-mixer for the vfo on 40 meters when the cathode of the triode section is grounded to activate the 21.5-MHz crystal oscillator.

The intermediate-frequency output of the 6BE6 receiver mixer is 9 MHz and the i-f signal is link-coupled via L₆ to the input of the 9-MHz crystal filter (FL₁). A matching transformer couples the low output imped-

ance of the filter to the grid circuit of the common i-f amplifier (V_3). The received signal is capacitively coupled from this stage to a second 6BA6 receiver i-f amplifier (V_{11}) whose output circuitry is capacitively coupled to a 6BE6 product detector (V_{12}). Oscillator injection for SSB reception is from either of the two sideband crystals in the grid circuit of the 7360 carrier oscillator-balanced modulator (V_2) which is common to receive and transmit sections. Collector plate voltage is removed from the 7360 during reception by relay RY_1C but the oscillator section always functions since deflector and screen voltage is applied in either mode.

The 6BE6 product detector (V_{12}) may be switched to function as a plate detector for reception of a-m signals (S_3, ABC). This changeover requires disabling the 7360 carrier oscillator, but since this oscillator is required for transmitting, the a-m changeover switch is routed through the main changeover relay (RY_1B) so voltage is applied to the carrier oscillator when transmitting, regardless of the setting of the SSB/a-m switch (S_3).

Mobile operation requires a receiver having a reserve of audio power and the audio section is designed to meet this requirement. Two 6EB8 triode-pentode tubes (V_{13}, V_{14}) are employed, with the pentode sections used as a push-pull audio stage. One triode section of the first 6EB8 is used as an audio phase inverter and the second triode is used as the driving amplifier for the phase inverter. The two dual-purpose tubes take up no more space than the usual two-tube amplifier stages but produce nearly 5 watts of high-quality audio. The speaker is not incorporated in the transceiver, since use of the speaker in the auto radio is contemplated. For home use, an auxiliary speaker is incorporated in the 115-volt a-c power unit.

The Transmitter Portion—The transmitter portion of the unit starts with a 12AX7 two-stage speech amplifier (V_1) driving a deflection plate of the 7360 carrier oscillator-balanced modulator (V_2). When transmitting, voltage is applied to the collector plates of the 7360 via relay RY_1C and the carrier is generated by the triode section

of the tube functioning as a crystal oscillator. Choice of upper or lower sideband is made by proper crystal selection by means of sideband-selector switch S_1 . The balanced-modulator plate circuit of the 7360 is link-coupled to the 9-MHz filter for rejection of the unwanted sideband and passage of the desired sideband to the common 6BA6 i-f amplifier (V_3). The sideband signal is then transformer-coupled to the 6BE6 transmitter mixer (V_4). This mixer stage receives its mixing voltage from the vfo and buffer pre-mixer stages (V_7, V_8) in the same manner as the receiver. Output of the 6BE6 transmitter mixer is at either 80, 40, or 20 meters and is bandpass-coupled on the desired band to a 12BY7 amplifier-driver (V_5). This stage, in turn, is bandpass-coupled to a neutralized 6DQ5 (V_6) serving as a class- AB_1 linear amplifier. The final tank circuit of the amplifier is a pi-network configuration providing good harmonic attenuation and ease of adjustment.

Transceiver Construction Transceiver construction is straightforward and should be no problem for the advanced amateur. The vfo is built as a separate unit and may be tested and aligned before it is installed in the transceiver. The receiver portion of the unit should be wired and tested before the various transmitter stages are completed. The transceiver is constructed on a 10" × 12" × 3" steel chassis. Layout of the major components and shield partitions are observed in the photographs and drawings. The 6DQ5 amplifier tube socket is recessed so that panel height is only 6½". Standard parts are used throughout with the exception of the vfo tuning capacitor. The vfo is built as a unit on the frame of a worm-gear driven capacitor removed from the amplifier stage of a surplus SCR-274N/ARC-5 transmitter. Only the worm gear and frame assembly are used and the original capacitor plates are removed (figure 32). A double bearing 140-pf receiving-type variable capacitor is installed in the frame in place of the original capacitor assembly, slipping the spring-loaded drive gear over the shaft of the new capacitor so that it engages the worm gear as did the rotor of the original capacitor. The free space inside the framework is used

PARTS LIST FOR FIGURE 31

C_1 —20-pf differential capacitor (E. F. Johnson 160-311)	#32 copper wire wound on 47-ohm, 1/2-watt resistor placed at cathode terminal of 6DQ5
C_2 —12-pf ceramic variable (Centralab CRL-827)	RFC—2.5-mH, 300-ma. (National R-300U)
C_3 —50-pf (Hammarlund MAPC)	RY ₁ —3PDT relay, 12-volt d-c coil (Potter-Brumfield KM-14D or equiv.)
C_4 —140-pf (Hammarlund MC-140M)	RY ₂ —DPDT relay, 12-volt d-c coil (Potter-Brumfield KM-11D or equiv.)
C_5 —25-pf ceramic variable (Centralab CRL-827)	S_1, A, B, C —3-pole, 2-position wafer switch (Centralab CRL PA1007)
C_6 thru C_{11} —50-pf ceramic variable (Centralab CRL-827)	$S_1, A, B; S_2, A, B; S_3, A, B; S_4, A, B; S_5$ —2-pole ceramic wafer sections (Centralab PA-2 each, ganged on Centralab PA-301 index assembly)
C_{12} —15-pf (Hammarlund MAPC).	T_1 —Transformer, 10.7-MHz TV i-f type, (J. W. Miller 1463). (x indicates internal component)
C_{13} —235-pf (Bud 1859)	T_2, T_3, T_4 —Transformer, 4.5-MHz TV interstage type (J. W. Miller 6270). (c indicates internal component)
C_{14} —1200-pf, 3-gang broadcast-type capacitor (J. W. Miller 2113)	T_5 —Universal output transformer, 10K plate-to-plate (Stancor A-3823)
CR ₁ thru CR ₂ —Diode, 1N34 or equivalent	Y_1 —8898.5-kHz crystal (furnished with FL ₁)
FL ₁ —9-MHz crystal sideband filter (McCoy SSB-9, McCoy Electronics, Mt. Holly Springs, Pa.)	Y_2 —9001.5-kHz crystal (furnished with FL ₁)
M—0.1 d-c milliammeter, 1 1/4" square (Cal-Rad, or equiv.).	Y_3 —21.50-MHz crystal (International Crystal Co. FA-5)
PC—Parasitic choke. 7 turns #18e. wire on 100-ohm, 1-watt composition resistor	
P_1 —8-contact chassis-mounting plug (Cinch-Jones P-308AB)	
R_1 —1-megohm potentiometer with switch S_2 attached	
R—Meter shunt for 300-ma range. Approx. 10"	

to mount the various components of the vfo as shown in the photograph. An aluminum plate is bolted to the back frame to support the tube socket (V_2) and an L-shaped shield is bolted over the top and end of the frame to inclose the assembly.

A circular dial cut from 1/16-inch plastic or plexiglas is placed on the large gear in lieu of the original metal dial. The new dial is spray-painted white on the front and calibration marks are lettered with India ink. The complete vfo is bolted to a base plate of 1/8" thick aluminum, slightly larger in area than the capacitor framework. The completed assembly is then bolted to the transceiver chassis with the center of the dial at the center line of the chassis. The plastic dial will extend below the front apron of the chassis, requiring a slight amount of clearance so that it does not rub. The panel is spaced away from the chassis apron by the lock washers and nuts that fasten the various controls, allowing clearance for the dial. The panel is secured in place with a second nut on each control. The upper edge of the panel and the rear lip of the chassis are bolted to the wrap-around cabinet to provide a rigid structure immune to vibration.

Component Layout—Most of the major components are mounted atop the chassis as shown in figures 33 and 34. The antenna

receptacle (J_3), power plug (P_1) and jack for the external speaker (J_2) are placed on the rear apron of the chassis and all other major controls are mounted on the front panel with the exception of the phase-balance capacitor (C_1) and voltage-balance potentiometer (R_2) which are placed on the chassis to the rear of the 7360 tube socket. These controls need be adjusted only in the initial alignment and ordinarily require no further attention.

The main bandswitch runs down the center line of the under-chassis area with wafer sections S_{1-7} (inclusive) bolted individually to the small partitions that act as interstage shields. Switch wafer S_6 for the 6DQ5 amplifier plate tank coil is mounted in the amplifier compartment on the rear apron of the chassis below tank coil L_{21} , with the connecting wires from the coil brought below deck through an oblong hole in the chassis. The shaft of this switch is ganged to the main bandswitch shaft by means of a link-and-arm arrangement shown in figure 35. Two small lever arms are made by taking apart a flexible shaft coupler. One arm is slipped over the main bandswitch shaft at the point where it enters the under-chassis shield plate behind the main panel, and the second arm is attached to the fiber extension shaft driving the am-

plifier switch wafer (S_8) mounted on the rear apron of the chassis. The two lever arms are interconnected by a narrow strip of aluminum having a hole at each end for small bolts to secure it to the two lever arms. Panel bushings in the shield plate act as bearings for the switch shafts.

The bandpass coils are constructed as indicated in the coil table (figure 36) with the exception of the coils for the 80 meter band. These are ready-made 4.5-MHz TV replacement interstage transformers (T_2 , T_3 , and T_1). They are used without alteration and provide the desired bandpass effect by virtue of stagger-tuning between 3.8 and 4.0 MHz.

A great deal of the wiring may be done before the shield partitions or switch assemblies are put in place. The switch wafers are installed one at a time, beginning with the receiver segment at the rear of the chassis. The side and front shield plates are made of thin aluminum and are installed last, being bolted to each other, the switch partitions, and the chassis to make a rigid assembly (figure 37).

Terminal boards are used for the small components of the balanced modulator and audio systems. Other small components are mounted to tube-socket terminals and tie-point terminal strips.

Testing and Alignment The transceiver will operate with any power supply capable of delivering between 500 and 800 volts at an intermittent load of 250 milliamperes for the final amplifier, and 250 volts at 125 milliamperes for the receiver and exciter sections. Bias requirement is -50 volts at 5 milliamperes (adjustable).

For fixed-station use and bench alignment, a voltage-doubler power supply using a TV replacement transformer works very well. Two 6.3-volt windings in series will provide filament voltage and this may be rectified to provide direct current to operate the relays. A -50 volt bias supply for the final amplifier stage is also required.

Alignment of VFO and pre-mixer—The first step in the alignment procedure is to adjust the main vfo to tune the range of 5.0 to 5.35 MHz. Since the vfo is made as

a separate assembly, it may be aligned and tested before installation on the chassis by applying voltage to the various terminals and monitoring the frequency in a well-calibrated receiver capable of tuning the operating range of the oscillator. A BC-221 frequency meter will aid in this effort. The 21.5-MHz crystal oscillator (V_8) and pre-mixer stage can be adjusted with a vacuum-tube voltmeter and r-f probe placed at the switch arm of S_5 A. With the bandswitch in the 80- or 20-meter position, a voltage will be observed at this point and the slug of coil L_{10} adjusted for maximum indication. This coil is broadly resonant in the 5-MHz region and is tuned for an output reading of not over 2 volts r.m.s.

With the bandswitch in the 40-meter position, the cathode of the triode section of the 6EA8 pre-mixer is connected to the cathode of the pentode section, energizing the crystal-oscillator stage and changing the circuit to a cathode-coupled mixer. The slug in the crystal-oscillator coil (L_{11}) is adjusted for maximum r-f voltage at the grid of the triode section of V_8 . The pre-mixer coils (L_8 and L_9) are tuned for maximum r-f voltage at the arm of switch S_5 A. The voltage measured at this point is the 16-MHz product of the crystal and vfo frequencies.

Receiver I-F and 80-meter Alignment—The receiver i-f amplifier is aligned by disabling the vfo and injecting a 9-MHz signal at the input grid (pin #7) of the 6BE6 receiver mixer (V_{10}). The i-f coils (L_1 , L_5 , L_7) and the primary *only* of transformer T_1 are tuned for maximum signal response using avc voltage as indication of resonance. With the bandswitch in the 80-meter position and the vfo functioning, a 4.0-MHz signal is injected at the antenna receptacle and the primary of r-f transformer T_2 tuned for maximum signal. This transformer is stagger-tuned by peaking the secondary at 3.8 MHz and checking at several points in between where a further slight adjustment of the slugs should result in a fairly flat response over the desired 200-kHz range. It will be noted that the final amplifier tank adjustment (which is the input circuit when receiving) must be peaked slightly when tuning from one end to the other of the 200-kHz range.

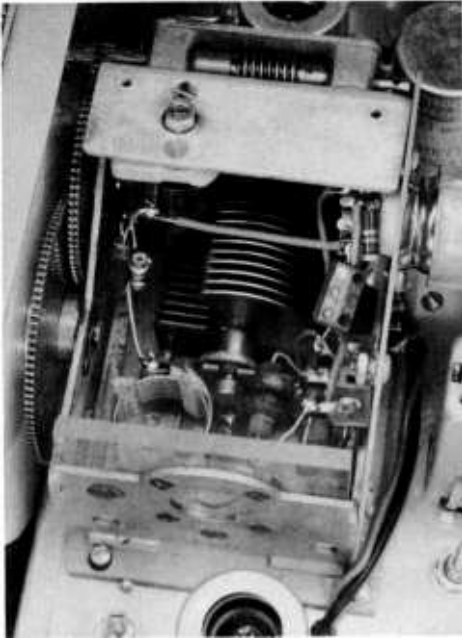

Figure 32

CLOSEUP OF TRANSCEIVER OSCILLATOR

Stable vfo for triband transceiver is made from frame of SCR-274N capacitor. Capacitor plates are removed and 140-pf capacitor substituted. A small bracket bolted to the frame supports padding capacitor C_1 . Airwound vfo coil is in foreground, cemented to a 1/4-inch thick block of polystyrene which is bolted to capacitor frame. Oscillator tube socket is mounted on side of capacitor and tie point behind it supports cathode r-f choke and various mica capacitors. Connections to vfo unit are terminated at lug strip mounted below the tube socket.

Receiver Alignment, 40 and 20 Meters—The tuning of the 40- and 20-meter band-pass r-f coils is done in a different manner. The grid coils (L_{23} , L_{25}) are temporarily unsoldered from the bandswitch (S_1B) to remove them from the active circuit and a grid-dip oscillator is used to set the frequency of the primary circuits (L_{22} , L_{21}) by adjustment of the slugs. The 40-meter plate coil is adjusted to 7.3 MHz and the 20-meter plate coil to 14.35 MHz. The grid coils are then resoldered to the bandswitch terminals and the 6BA6 r-f amplifier tube (V_9) is removed from its socket. This raises

the resonant frequency of the primary windings so they will not affect the adjustment of the grid circuitry. The grid coils are then dipped to 7.0 and 14.0 MHz. With the r-f tube back in its socket, the transceiver can be turned on and checked for receiver operation on each band.

Transmitter Alignment Alignment of the transmitter section is done with the high voltage disconnected and with screen voltage removed from the 6DQ5 amplifier. If the OA2 screen-regulator tube is wired so that the dropping resistor goes to pin #1 and the screen lead to pin #5, the screen voltage will be disconnected by removing the OA2 from its socket, since the OA2 has an internal jumper between these pins.

Much of the transmitter alignment is completed once the receiver section has been adjusted. The 7360 balanced-modulator plate coil (L_1) is tuned first, placing the r-f probe of the v.t.v.m. at the grid (pin #7) of the 6BE6 transmitting mixer (V_4) to obtain an r-f voltage reading. The transmitter circuitry is energized by pressing the push-to-talk switch on the microphone (with the microphone gain control R_1 turned down). The carrier control (R_3) is turned on and advanced to provide carrier injection until a reading is obtained on the v.t.v.m. The slug of coil L_1 is adjusted for maximum r-f indication. The phase-balance capacitor (C_1) should be set for equal capacitance and the voltage-balance potentiometer (R_2) set near the center of rotation. When the carrier control is turned off, the indicated r-f voltage will drop and balance potentiometer R_2 should be adjusted for a minimum r-f reading. This is the adjustment for carrier suppression and at this time the phase-balance capacitor should be adjusted slightly to achieve lowest possible r-f reading. Both controls affect carrier suppression and are slightly interlocking and should be adjusted in sequence for lowest reading on the v.t.v.m. The whole process may be monitored with a receiver used as an r-f probe with the antenna lead placed near the socket of the 6BE6 transmitter mixer tube (V_4).

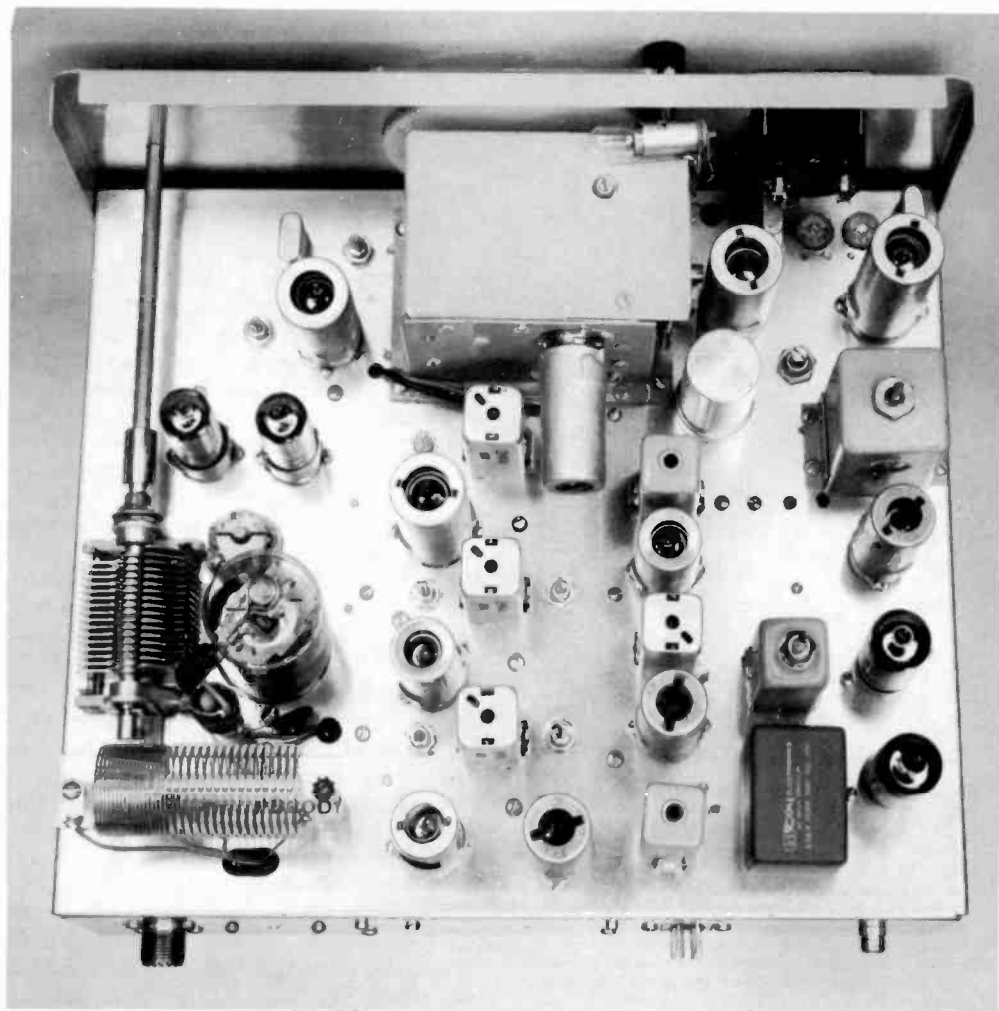

Figure 33

TOP VIEW OF TRIBAND TRANSCEIVER

Identification of various components may be done by comparison to chassis-layout drawing (figure 34). Variable-frequency oscillator is centered behind panel which is spaced away from chassis to allow clearance for circular dial. Pilot lamp is atop oscillator compartment, with oscillator padding capacitor (C_1) adjustable from top of compartment. Carrier crystals and their padding capacitors (C_2 - C_3) are visible below panel meter at right. Across the rear chassis apron are (l. to r.): Antenna coaxial receptacle (J_1), power receptacle (P_1) and speaker jack (J_2).

Carrier Oscillator Adjustment—Capacitors C_1 and C_2 across the upper- and lower-sideband crystals are used to trim the crystal frequencies for proper positioning of the carrier on the slope of the sideband filter. To realize the rated sideband rejection of 40

decibels, the carrier oscillator should be placed 1500 Hz above or below the 9-MHz center frequency of the filter. Carrier suppression is also affected by proper positioning of the carrier frequency on the filter slope. When making the frequency adjust-

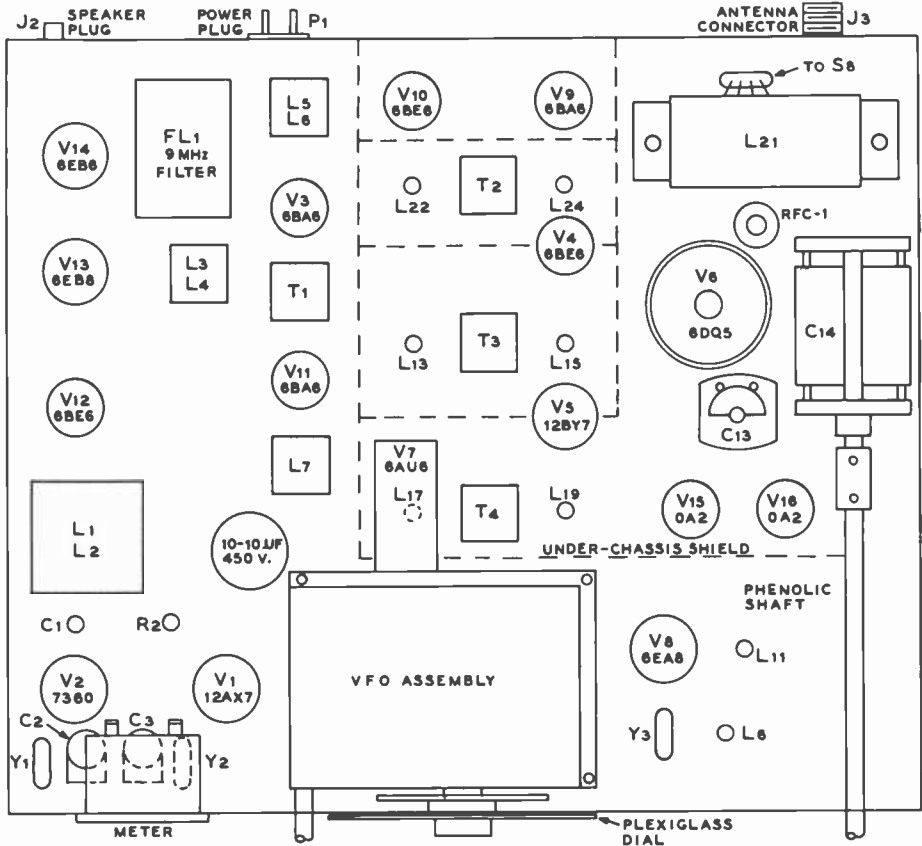

Figure 34

PLACEMENT OF MAJOR COMPONENTS ON TRANSCEIVER CHASSIS

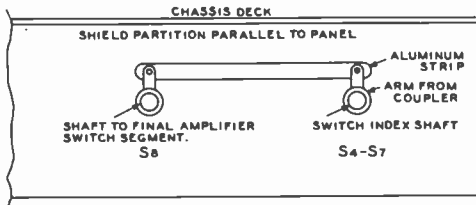

Figure 35

BANDSWITCH ARM DETAIL

turned off should be very nearly the same with either crystal. Final adjustment may be made with voice modulation, striving for good audio quality on either sideband as monitored in a nearby receiver.

Bandpass Adjustment—The bandpass circuits in the linear amplifier stages of the transmitter are aligned in the same manner as the receiver circuits using carrier injection from either sideband crystal. The 40- and 20-meter coils are checked with a grid-dip oscillator as before, but the 80-meter transformers (T_3 , T_4) as well as the secondary of T_1 , are adjusted with voltage applied to the transmitter and the transformer slugs

ments, carrier suppression should be checked on both upper- and lower-sideband positions. The minimum voltage reading with carrier

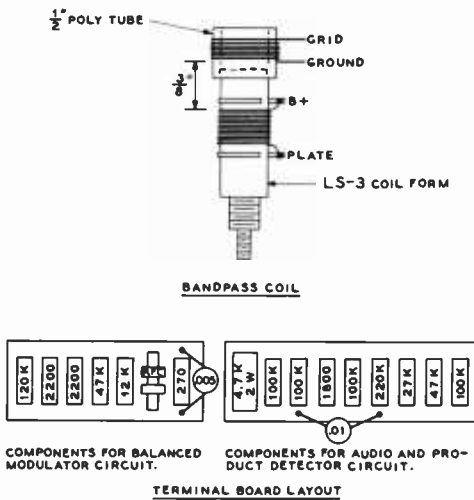

Figure 36

COIL TABLE FOR TRANSCEIVER

- L_1 —12 bifilar turns (24 in all) #24 enamel wire, closewound on slug-tuned form, $\frac{1}{2}$ " diam. (National XR-50). Tune to 9 MHz
- L_2 —4 turns #24 hookup wire around center of L_1
- L_3 —4 turns #24 hookup wire on "cold" end of L_1
- L_4 , L_5 , L_6 —30 turns #30 enamel closewound on $\frac{5}{16}$ " diameter form. Tune to 9 MHz
- L_7 —4 turns #24 hookup wire on "cold" end of L_4
- L_8 —12 turns #24 enamel closewound on $\frac{3}{8}$ " diam. slug-tuned form (CTC-LS3 or equiv.). Tune to 16 MHz
- L_9 —8 turns #24 enamel wire closewound on $\frac{3}{8}$ " length of $\frac{1}{2}$ " diam. polystyrene tubing slipped over top end of coil L_8 to make premixer transformer. Tune to 16 MHz
- L_{10} —Ferrite rod loop-antenna coil ("loopstick") with turns removed to resonate to 5MHz (J. W. Miller 6300)
- L_{11} —15 turns #24 enamel wire closewound on $\frac{3}{8}$ " diam. slug-tuned form (CTC-LS3). Tune to 21.5 MHz.
- L_{12} — $7\frac{1}{2}$ turns #20, $\frac{3}{4}$ " diam., $\frac{3}{4}$ " long (B & W 3011). Tunes 5.0 to 5.35 MHz
- L_{13} , L_{14} , L_{15} —30 turns #30 enamel wire closewound on $\frac{3}{8}$ " diam. slug-tuned form (CTC-LS3). Tune to 7 MHz
- L_{16} , L_{17} , L_{18} —25 turns #30 enamel wire closewound on $\frac{3}{8}$ " length of $\frac{1}{2}$ " diam. polystyrene tubing cemented to top of L_{13} , L_{14} , L_{15} to make bandpass transformer (see sketch). Tune to 7 MHz
- L_{19} , L_{20} , L_{21} —14 turns #28 enamel wire closewound on $\frac{3}{8}$ " diam. slug-tuned form (CTC-LS3). Tune to 14 MHz
- L_{22} , L_{23} , L_{24} —12 turns #28 enamel closewound on $\frac{3}{8}$ " length of $\frac{1}{2}$ " diam. polystyrene tubing cemented to top of L_{19} , L_{20} , L_{21} to make bandpass transformer. Tune to 14 MHz

L_{22} —Final amplifier tank coil. 32 turns #16 wire, with 16 turns spaced twice wire diameter; 16 turns spaced wire diameter. Coil is 1" diam., $2\frac{1}{2}$ " long, tapped at 10 and 18 turns from plate end. (Air-Dux 820-D10).

Note: L_1 , L_2 , and L_3 are mounted in $\frac{3}{4}$ " square shield cans similar to transformer T_1 .

tuned for uniform 6DQ5 drive-voltage reading over the 200-kHz tuning range with the r-f probe placed at the grid of the 6DQ5. A maximum of 15 to 20 volts rms can be obtained with full carrier injection. Under final operating conditions, the 40- and 20-meter coils may require some slight adjustment for uniform drive across these bands.

Amplifier Neutralization—The last step is to neutralize the final amplifier stage. With plate and screen voltage removed and grid drive applied to the 6DQ5, neutralization is accomplished by placing the r-f probe at the antenna receptacle and adjusting neutralizing capacitor C_{13} for minimum r-f indication when the 6DQ5 tank circuit is tuned to resonance.

Final Amplifier Adjustment—Amplifier bias is adjusted to provide 50 ma of resting current. The transceiver should be coupled to a dummy load and loading and grid drive (carrier insertion) adjusted to provide the desired input level.

Antenna loading requires that a fixed ratio of grid drive to plate-load impedance be achieved. Maximum drive level is fixed and loading is accomplished at this level and may be increased until flat-topping is first observed on a monitor oscilloscope. Advantage is taken of the high peak-to-average-power ratio in the human voice, and up to 200 watts peak input may be run to the 6DQ5 without overheating the tube. Carrier injection and tune-up conditions, on the other hand, impose maximum dissipation conditions on the tube and tune-up operation at full input should be limited to periods of 20 seconds or less in one minute as tube dissipation runs near 65 watts or so under these conditions. With the average voice, peak plate-current indication on the meter will run below 50 percent of the full carrier injection plate current, even taking into account the alc action of this circuit. Thus, under intermittent carrier tune-up

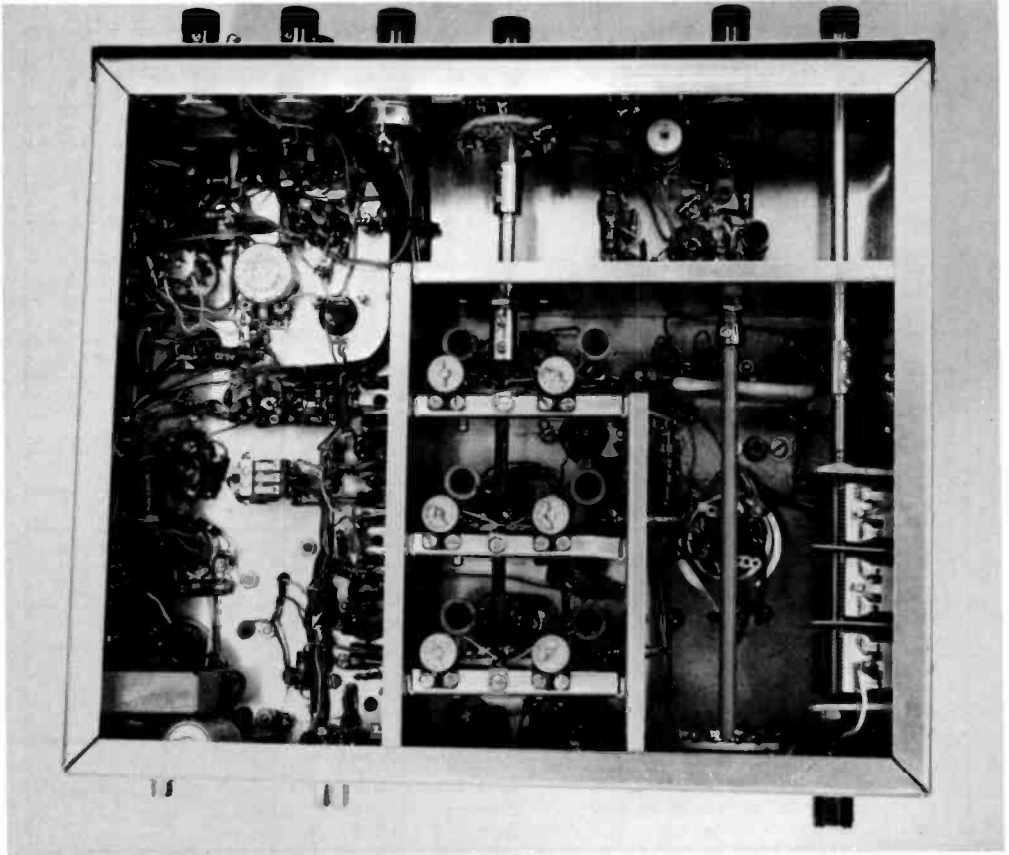

Figure 37

UNDER-CHASSIS VIEW OF TRANSCEIVER

Placement of shield partitions about tuned circuits may be seen at right side of chassis. Trimming capacitors for 40- and 20-meter circuits are mounted on partitions as are switch decks. First switch segment behind front panel is S_2 . The three-gang antenna loading capacitor is bolted to the side apron of the chassis near antenna receptacle and tank switch wafer S_3 . The opposite side apron is used to mount the audio output transformer (T_1) and two terminal boards that support most of the resistors and capacitors in the audio and balanced modulator circuits. Terminal strips and tie points are used to mount small components securely to resist vibration encountered in mobile work. The antenna relay (RY_1) is mounted on the rear apron above the 6BE6 (V_{10}) socket. The voltage changeover relay RY_2 is mounted in the center of the chassis area between the i-f amplifier tubes and the audio tubes.

at 800 volts plate potential, maximum plate current may run as high as 275 to 300 milliamperes, with indicated voice peaks running about 125 to 175 milliamperes meter

reading. Excessive peak plate current readings under voice conditions indicate flat-topping and consequent distortion of the signal.

CHART 2

TUBE SOCKET VOLTAGE CHART									
TUBE	1	2	3	4	5	6	7	8	9
V ₁	100	-2	0	F	F	180	-0.5	1	-
V ₂	3	150	-	F	F	220	220	18	18
V ₃	-	0	F	F	220	100	1.8	-	-
V ₄	-	2	F	F	240	75	0	-	-
V ₅	2	-	0	F	F	F	240	110	0
V ₆	-50	F	-	150	-50	-	F	150	-
V ₈	100	-	125	F	F	200	3	3	-
V ₉	-	0	F	F	220	100	1.8	-	-
V ₁₀	-	2.5	F	F	225	80	0	-	-
V ₁₁	-	1.8	F	F	220	100	1.8	-	-
V ₁₂	-	0.8	F	F	200	35	0.8	-	-
V ₁₃	1	-	100	F	F	3	-	180	240
V ₁₄	70	-	175	F	F	3	-	180	240

NOTES:
 Readings taken with 20,000 ohms-per-volt meter and may vary 10%.
 Voltages—0 on pins 6, 7, 8, 9, of V₂ on receive.
 Voltage—120 on pin 2 of V₂ on receive.
 R-f gain and audio gain fully advanced.

POWER-SUPPLY REQUIREMENTS

Low voltage—250 volts at 115 ma receive	High voltage—600 to 800 volts at 300 ma, xmit only
80 ma xmit	Filaments—12.6 volts a.c. or d.c. at 4 A
Bias—50 volts d.c. 5 ma	Relay—12 V.D.C. 80 ma, xmit only

Transceiver The triband transceiver output circuit is designed for a nominal 50-ohm load. Low-frequency whip antennas, particularly 80-meter loaded whips present a low-impedance load which may inhibit proper transceiver loading under certain conditions. If this situation exists, there are several solutions to the problem. The easiest one to apply is to change the length of the coaxial line running from the transceiver to the antenna. By lengthening the line in five- or ten-foot increments, a condition of proper load may be achieved, even though the SWR on the transmission

line remains quite high. A better solution is to make use of an auxiliary impedance-matching coil placed at the base of the antenna, as shown in figure 16A. Typically, a matching coil for 80 meters may consist of about fifteen turns of No. 12 wire, 1 inch in diameter and about 2 inches long. The number of active turns in the coil are adjusted, one by one, and the SWR on the transmission line monitored. A proper impedance match will drop the SWR to a value less than 1.2/1 at the resonant frequency of the loaded antenna.

Receivers and Transceivers

Receiver construction has just about become a lost art. Excellent general-coverage and ham-band-only receivers are available on the market in many price ranges. However, even the most modest of these receivers is relatively expensive, and most of the receivers are designed as a compromise—they must suit the majority of users, and they must be designed with an eye to the price.

It is a tribute to the receiver manufacturers that they have done as well as they have. Even so, the c-w man must often pay for a high-fidelity audio system and S-meter he never uses, and the SSB operator must pay for the c-w man's narrow-band filter. For one amateur, the receiver has too much bandspread; for the next, too little. For economy's sake and for ease of alignment, low-Q coils are often found in the r-f circuits of commercial receivers, making the set a victim of crosstalk and overloading from strong local signals. Rarely does the purchaser of a commercial receiver realize that he could achieve the results he desires in a home-built receiver *if* he left off the frills and trivia which he does not need but which he must pay for when he buys a commercial product.

The ardent experimenter, however, needs no such arguments. He builds his receiver merely for the love of the game, and the thrill of using a product of his own creation.

It is hoped that the receiving equipment to be described in this chapter will awaken

the experimenter's instinct, even in those individuals owning expensive commercial receivers. These lucky persons have the advantage of comparing their home-built product against the best the commercial market has to offer. Sometimes such a comparison is surprising.

When the builder has finished the wiring of a receiver it is suggested that he check his wiring and connections carefully for possible errors before any voltages are applied to the circuits. If possible, the wiring should be checked by a second party as a safety measure. Some transistors can be permanently damaged by having the wrong voltages applied to their electrodes. Electrolytic capacitors can be ruined by hooking them up with the wrong voltage polarity across the capacitor terminals. Transformer, choke, and coil windings may be damaged by incorrect wiring of the high-voltage leads.

The problem of meeting and overcoming such obstacles is just part of the game. A true radio amateur should have adequate knowledge of the art of communication. He should know quite a bit about his equipment (even if purchased) and, if circumstances permit, he should build a portion of his own equipment. Those amateurs who do such construction work are convinced that half of the enjoyment of the hobby may be obtained from the satisfaction of building and operating their own receiving and transmitting equipment.

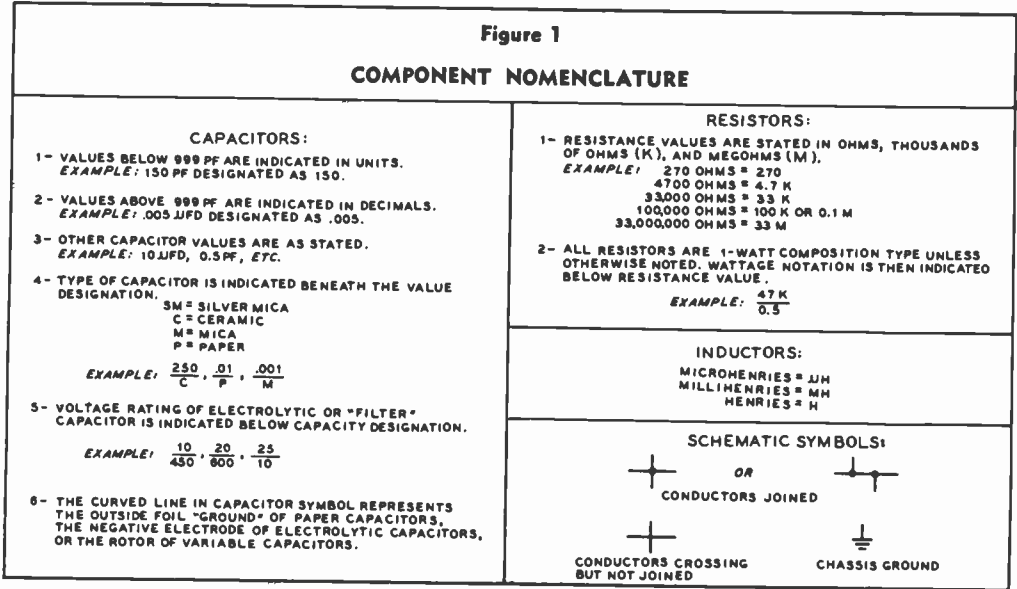

The Transceiver A popular item of equipment on "five meters" during the late '30's, the *transceiver* is making a comeback today complete with modern tubes and circuitry. In brief, the transceiver is a packaged radio station combining the elements of the receiver and transmitter into a single unit having a common power supply and audio system. The present trend toward compact equipment and the continued growth of single-sideband techniques combine naturally with the space-saving economies of the transceiver. Various transceiver circuits for the higher frequency amateur bands are shown in this Handbook. The experimenter can start from these simple circuits, and using modern miniature tubes, transistors, and components, can design and build his complete station in a cabinet no larger than a communications receiver.

Circuitry and Components It is the practice of the editors of this Handbook to place as much usable information in the schematic illustration as possible. In order to simplify the drawing, the component nomenclature of figure 1 is used in all the following construction chapters.

The electrical value of many small circuit components such as resistors and capacitors is often indicated by a series of colored bands

or spots placed on the body of the component. Several color codes have been used in the past, and are being used in modified form at present to indicate component values. The most important of these color codes for resistors, capacitors, power transformers, chokes, i-f transformers, etc. can be found in the appendix at the end of this Handbook.

26-1 A General Purpose High-Frequency Converter

This converter is an improved version of the "Antioverload 50-MHz Converter" featured in the 17th edition of the *Radio Handbook*. The newer version has improved overload capability, better noise figure, and is adapted for use on the 6-, 10-, and 15-meter bands.

The problem of overload and cross modulation is acute in metropolitan areas having high density of amateur operation, and many receivers fail to provide adequate reception when in the presence of a strong nearby signal. This converter provides overload protection to unwanted signals as strong as 100,000 microvolts, removed from the listening frequency by only 50 kHz at 21 MHz. With this superior overload per-

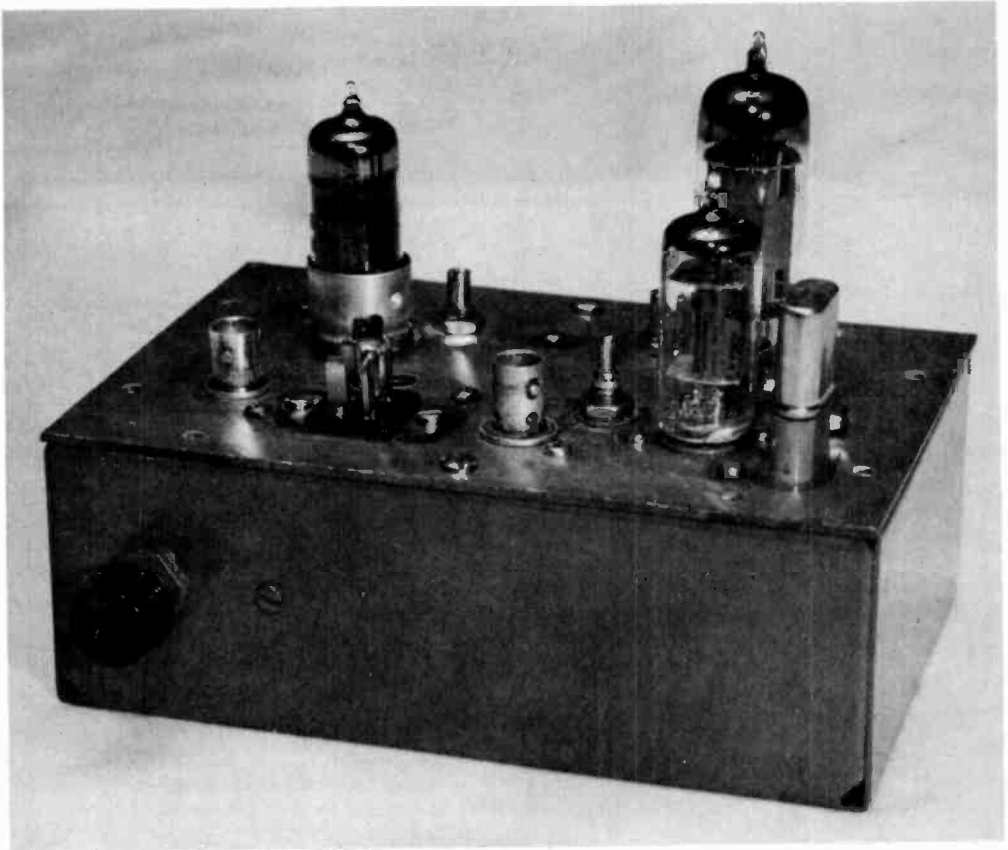

Figure 2

THE GENERAL PURPOSE HIGH-FREQUENCY CONVERTER

Excellent high-signal overload characteristics and freedom from cross modulation are featured in this simple converter. Antenna receptacle and 6BZ6 r-f amplifier tube are at the left of the unit. A tube shield should be placed over the 6BZ6. The r-f gain control is on the front of the aluminum chassis box. The conversion crystal and 6C4 oscillator are at the right, with the 12AT7 mixer to the rear. The converter is built on a copper-laminate phenolic circuit board.

formance, the noise figure of the converter is such that it reaches the level of external noise, or better, at all operating frequencies, exhibiting a noise figure better than 5 decibels at 50 MHz.

Circuit Description The schematic of the antioverload converter is shown in figure 3. A 6BZ6 semiremote-cutoff pentode is used as an r-f amplifier, having a cathode gain control to permit adjustment of stage gain in the presence of strong signals. A 12AT7 double-triode mixer is used, which has an exceptionally large dynamic signal range, that provides low cross-

modulation effects up to an input level of nearly 0.7 volt. A 6C4 fundamental-frequency mixing oscillator is used. Coupling between the r-f amplifier plate coil (L_3) and the 12AT7 mixer grid coil (L_6) may be varied to suit the strong-signal situation by adjustment of link coils L_4 and L_5 .

The 6C4 crystal oscillator is capacitively coupled to one section of the 12AT7, which acts as a cathode follower for the second section, which in turn, is grid-driven by the incoming signal. A third-overtone crystal is used to produce a 7- to 11-MHz intermediate frequency range. Plate voltage for the 6C4 oscillator is fed separately from

TABLE I
COIL TABLE FOR GENERAL-PURPOSE H-F CONVERTER

Band	Coil L ₂ L ₃ , L ₄	Approx. Ind. (μ H)	Coil L ₁ , L ₄ , L ₅
6	8 to 10 turns #16e., $\frac{5}{8}$ " diam. \times 1" long (Air-Dux 516-T)	0.7 μ H	2 turns hookup wire at cold end
10	14 turns #18e., $\frac{5}{8}$ " diam. \times $\frac{1}{2}$ " long (Air-Dux 532-T)	2.2 μ H	2 turns hookup wire at cold end
15	24 turns #18e., $\frac{1}{2}$ " diam. \times $\frac{3}{4}$ " long (Air-Dux 432-T)	4 μ H	3 turns hookup wire at cold end

Note: Adjacent cold ends of L₃ and L₄ are $\frac{3}{4}$ " apart.

L₅—40 turns #28e., wire closewound on $\frac{3}{8}$ " diam. slug-tuned form. (J. W. Miller 42A-OOOCBI)
L₆—3 turns hookup wire over B-plus end of L₅.

OSCILLATOR DATA		
BAND	CRYSTAL (MHz)	COIL L ₇
6	43 MHz	10 turns #28e., closewound on $\frac{1}{2}$ " diam. slug-tuned form (1.8 μ H). (J. W. Miller 41A-OOOCBI)
10	21 MHz	Same as for 6 meters, with 50-pf variable mica capacitor in parallel
15	14 MHz	Same as for 6 meters, with 100-pf variable mica capacitor in parallel

the rest of the converter so that the oscillator may be turned off during periods of transmission.

Converter Construction The converter is built on a 4" \times 6" copper-laminate (two sides) phenolic circuit board. A 4" \times 6" \times 2" aluminum chassis box serves as a base and as a shield for the wiring and components. All components except the manual gain control (R₁) are mounted on the chassis plate. The gain control mounts on the chassis box as shown

in figure 4. A short length of flexible hookup wire connects the potentiometer terminal to a phenolic tie-point mounted on the plate. The ground terminal of the gain control is grounded to the plate by a separate lead so that an electrical connection is made if the converter is operated outside of the box. This permits the chassis plate to be swung up and out while the converter is aligned and tested.

The usable area of the chassis plate is 3" \times 5" since a one-half inch border around the plate must be left to clear the chassis

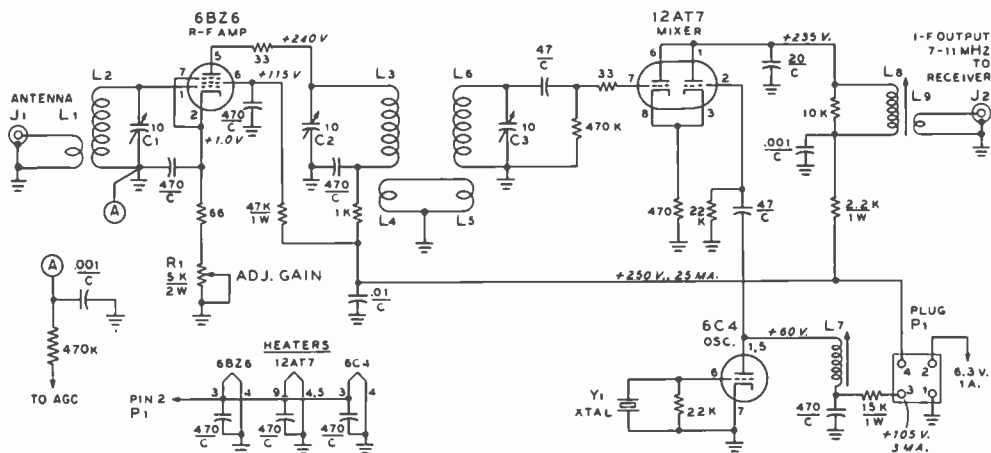

Figure 3

SCHEMATIC OF GENERAL PURPOSE HIGH-FREQUENCY CONVERTER

C_1, C_2, C_3 —10-pf miniature capacitors (Johnson 160-107 or equiv.)

J_1, J_2 —Coaxial receptacle, BNC type UG-625/u

L_1-L_6 —See coil table

P_1 —4-pin chassis-mounting plug. (Cinch-Jones P-304AB or equiv.)

All resistors $\frac{1}{2}$ watt unless otherwise noted.

base lip. All parts (except the gain control) must be located inside the border. Self-tapping screws secure the chassis-plate to the box.

Placement of the major components may be seen in the under-chassis view (figure 5) and the drilling layout (figure 4). The three air-wound coils are made of sections of *miniductor* coil stock. A heated razor blade held with pliers is a good tool to sever the plastic ribs when cutting the coil stock to length. The coils are mounted in place by their leads.

A small shield is placed across the 6BZ6 socket to prevent oscillation of the r-f stage. The shield is cut from thin "flashing" copper and measures 2" long by $\frac{3}{4}$ " high. It is soldered to the chassis plate at either side of the socket and to the socket center post. The shield should be placed in position before wiring is started.

Most of the small components are supported by their leads, between socket pins, or from socket pin to nearby phenolic tie-point terminals. All leads are short and direct. The drilling layout shows the location of the major components. If other components are substituted for the ones

used, it would be wise to check the layout before drilling any holes as space is rather limited in some areas.

Adjustment of the Converter A regulated supply voltage of 105 volts at 3 milliamperes is required for the oscillator and 250 volts at about 25 milliamperes for the r-f and mixer stages. The 6C4 may be operated from the 250-volt supply without regulation if an additional series dropping resistor of 50,000 ohms, 2 watts is placed between pins 3 and 4 of plug P_1 . Filament power for the converter is 6.3 volts at 0.75 ampere.

Wiring should be rechecked before power is applied to the converter, and the tuned circuits are resonated with a grid-dip oscillator. The crystal-oscillator stage is checked by listening for oscillation in a nearby receiver or by noticing the change in oscillator plate current. A milliammeter may be inserted in series with pin No. 3 of the power plug for this observation.

The 6BZ6 and 12AT7 tubes are now inserted in the proper sockets, the converter is attached to the receiver tuned to the intermediate-frequency range, and a low-

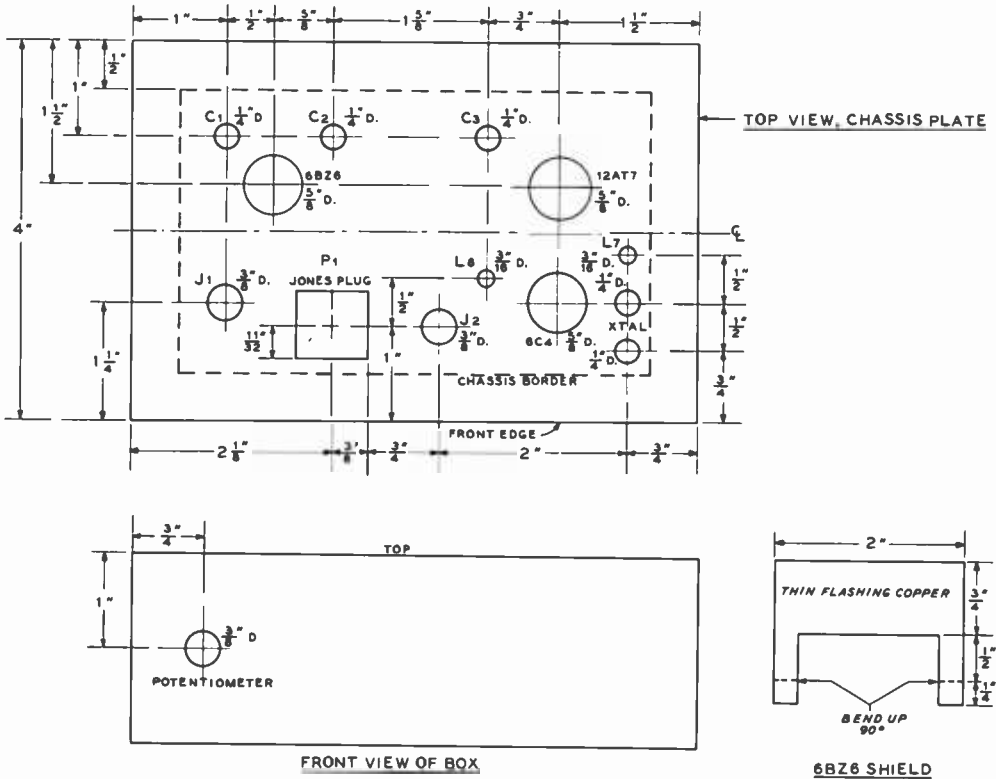

Figure 4
DRILLING LAYOUT FOR CONVERTER PLATE, SOCKET SHIELD, AND CHASSIS BOX

level signal of the desired frequency band is injected into the antenna receptacle of the converter. The various tuning capacitors are adjusted for maximum signal response.

Final adjustment of coupling coils L_4 and L_5 should be done after the user has had experience with the converter in the presence of strong local signals. With all circuits peaked for maximum signal, the link-coupling coils should be adjusted for minimum signal consistent with good reception and the prevailing state of nearby strong signals. Too close coupling will limit the ability of the converter to withstand strong local signals and too loose coupling will result in an excessive loss of gain. Adjustment of the link coils coupled with experimentation with the gain control will achieve the ultimate in usable sensitivity and excel-

lent overload capability.

For flattest response across the whole 50-MHz band, capacitors C_1 , C_2 , and C_3 should be stagger-tuned. Capacitor C_2 is the sharpest tuning of the three circuits, and should be peaked at the center of the operating range to be covered. Coil L_6 should be adjusted to provide maximum gain at the center of the operating range. As a starter, capacitor C_1 should be peaked at 50.5 MHz, capacitor C_2 at 51 MHz, and capacitor C_3 at 52 MHz. If the converter is to be used only in the lower one megahertz of the band, all circuits may be peaked at 50.5 MHz. Adjustment of link coil L_1 and tuning of input capacitor C_1 have an effect on the noise figure of the converter. These adjustments may be made on a weak signal or with the aid of a noise generator.

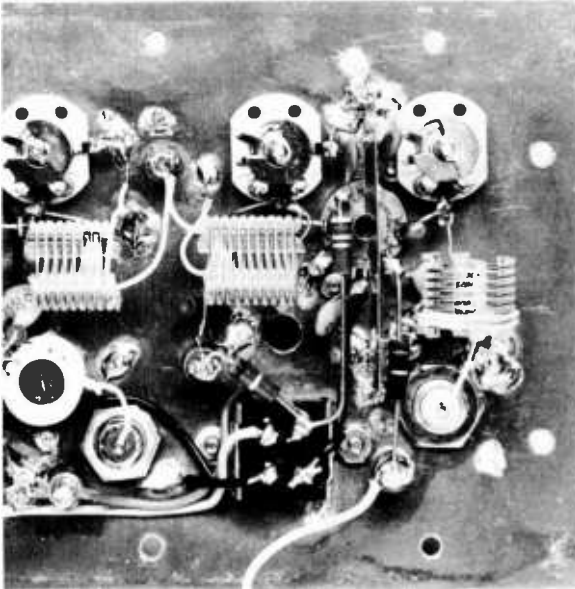

Figure 5

UNDER-CHASSIS VIEW OF CONVERTER

Right to left across the upper edge of the chassis-plate are tuning capacitors C_1 , C_2 , and C_3 . A copper flashing shield straddles the 6BZ6 tube socket at right. Adjacent ends of coils L_1 and L_2 are spaced about $\frac{3}{4}$ " apart, with "cold" ends facing each other (center of chassis). Interstage coupling is adjusted by positioning links inside the coils. A phenolic tie-point insulator located to one side and between the two coils serves to support the ungrounded link connection. Other ends of links are grounded to chassis plate.

26-2 A Low-Noise MOSFET Converter for 2 Meters

The 3N140 dual-gate field-effect (MOSFET) transistor is an N-channel depletion type silicon device that proves very effective in vhf service. The 2-meter converter described in this section (figure 6) uses two inexpensive dual gate MOSFETs which combine high input resistance, low input capacitance, very low feedback capacitance, and low noise figure at very high frequencies. Neutralization is unnecessary in properly constructed r-f stages since the gate to source capacitance of the 3N140 is only 0.03 pf.

The MOSFET is relatively insensitive to temperature variations, making the converter completely stable under varying conditions of use. Typically, the noise figure of this converter is better than 2.5 decibels and the usable passband without tuning readjustment is 1 MHz or more. Best of all, the MOSFET exhibits a large-signal cross-modulation characteristic that approaches that of a good remote-cutoff vacuum tube, thus overcoming the handicap of poor cross-modulation characteristics exhibited by bi-

polar transistors when used in this service.

Circuit Description The schematic of the 2-meter MOSFET converter is given in figure 7. A 3N140 (Q_1) is used as a low-noise unneutralized high-gain r-f amplifier in a common-source circuit. A conventional pi-network input arrangement is used to match the high input impedance of the MOSFET to a low-impedance coaxial transmission line. The drain circuit of transistor Q_1 is resonated to the input frequency by a high-Q parallel-tuned circuit (C_2 - L_2) which is capacitively coupled to a second 3N140 MOSFET (Q_2) acting as a common-source mixer. The amplified signal is applied to a resonant circuit (C_3 - L_3) and gate 1 of the mixer, and the local oscillator is coupled to gate 2. The resulting intermediate-frequency signal is taken from the drain circuit. The mixer stage is flexible enough so that the converter may be used with receivers of various intermediate-frequency tuning ranges by changing the injection frequency to the converter and readjusting output circuit L_1 .

For simplicity in construction and maximum flexibility in use, the local-oscillator chain is assembled as a separate unit using bipolar transistors, and the schematic for

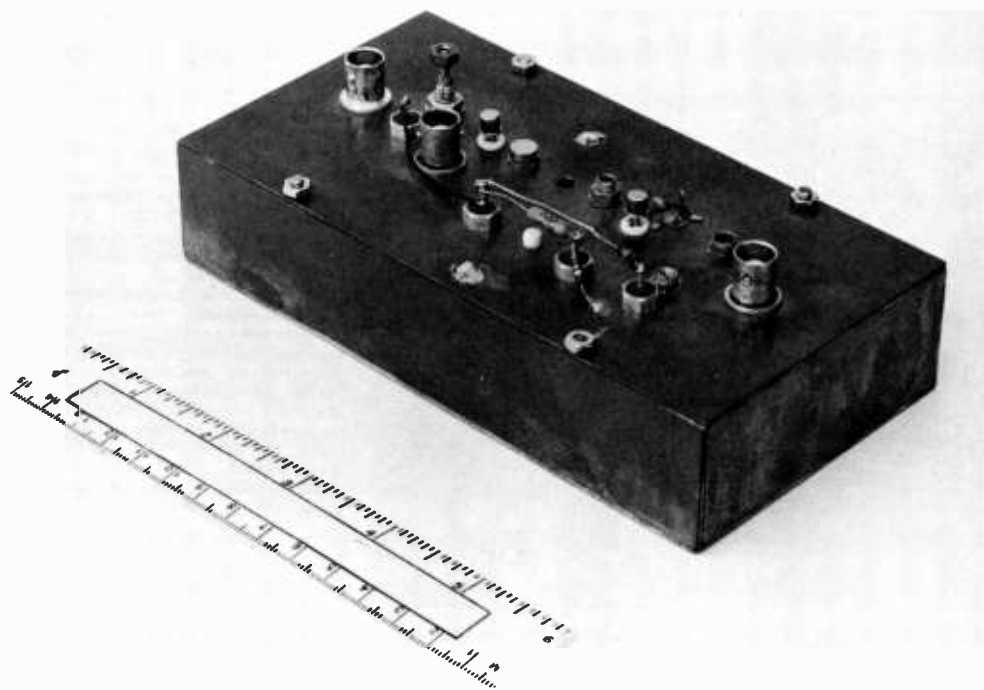

Figure 6

COMPACT MOSFET CONVERTER FOR 144 MHz

This low-noise DX converter employs two MOSFET dual-gate transistors as an r-f amplifier and as a mixer. A separate local-oscillator chain is used for maximum flexibility. This converter has been used for successful 2-meter SSB moonbounce communication between Europe and the western United States.

At the right of the deck is the antenna receptacle and the r-f amplifier MOSFET with input- and output-circuit tuning capacitors adjacent to the MOSFET socket. To the left is the mixer stage, with the local-oscillator injection receptacle in front of the MOSFET socket. The i-f output receptacle is at the extreme left of the deck. The resistors and r-f choke in the gate-2 circuit of the mixer MOSFET are mounted atop the chassis at the front.

a typical unit is shown in figure 9.

This converter was designed and built by K6MYC and has been used for successful 2-meter SSB moonbounce contacts between Europe and the western United States, attesting to its superior noise figure and overall performance.

Converter Construction The MOSFET converter is constructed on a piece of copper-clad (2 sides) glass epoxy circuit board measuring $6\frac{1}{2}'' \times 3\frac{1}{4}''$. A matching shield case $1\frac{1}{4}''$ deep is made of the same material soldered into a small box. Placement of the major components may be

seen in the photographs (figures 6 and 8) and layout drawing (figure 10).

A small shield measuring $\frac{3}{4}'' \times 2''$ is cut out of thin copper shim stock, or of circuit-board material and is soldered in place between MOSFET socket Q_1 and coil L_2 to reduce unwanted interstage coupling. A second similar shield measuring $1\frac{1}{4}'' \times \frac{3}{4}''$ separates this coil from coil L_3 . The first shield is positioned adjacent to the Q_1 socket, with the drain lead from the socket passing through a small hole drilled in the shield and on to capacitor C_2 . Placement of the various small components is not particularly critical and they are grouped about

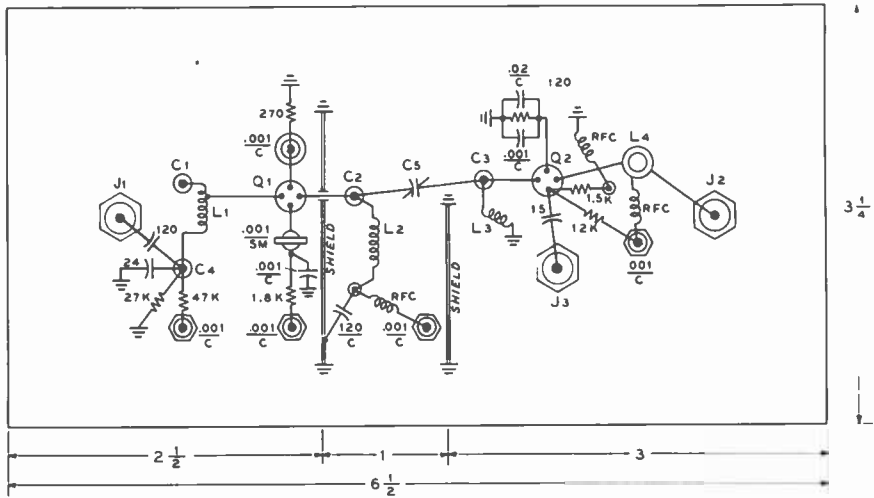

Figure 10

UNDER-CHASSIS PARTS LAYOUT FOR CONVERTER

voltage "spikes" that may play havoc with transistors of any type. Initial testing may be done with dry batteries, since converter power drain is very low.

After the power supply is connected to the converter, a coaxial cable from the local-oscillator unit is connected to the injection receptacle (J₃) and a low-level mixing signal applied to the converter. Local-oscillator action may be checked in a nearby receiver, and it should be noted that the converter noise level rises when the injection signal is applied.

Since the tuned circuits are roughly in resonance, 2-meter signals should be heard when the converter is attached to an external antenna. Once the converter is found to be working, all tuned circuits are adjusted for maximum received-signal level.

Final adjustment is accomplished by re-adjusting the converter for best signal-to-noise ratio, regardless of converter gain. The noise figure is adjusted by varying the level of mixer injection voltage and by proper adjustment of the pi-network input circuit. This can best be done by listening to a weak signal, such as a remote crystal oscillator connected to a small antenna. Alternatively, a noise generator may be employed. All tuning adjustments are made with the end

view of obtaining better signal to noise ratio, rather than merely greater signal strength. Exact tuning will depend on circuit loading and the reactance of the external antenna system and is best determined by experiment.

As a starter, a 50-ohm carbon resistor is used for a dummy antenna, placed across the terminals of receptacle J₁. The converter is tuned up for maximum noise level. The resistor is removed and the 50-ohm antenna system is connected in its place. If the noise level rises appreciably, the external noise is the limiting factor in vhf reception, and any receiver system improvement past this point must be accomplished by increasing the capture area (size) of the antenna and reducing the receiver passband. Adjustment of all circuits must be made for the greatest margin of received signal over receiver noise, using weak, received signals for this test.

The converter should be protected from strong input signals, such as might be generated by the station transmitter. Signal inputs of more than a tenth of a volt or so might damage one or both MOSFETs. Good input protection can be achieved by placing a pair of 1N100 germanium diodes in parallel, back to back, across antenna receptacle J₁ to ground.

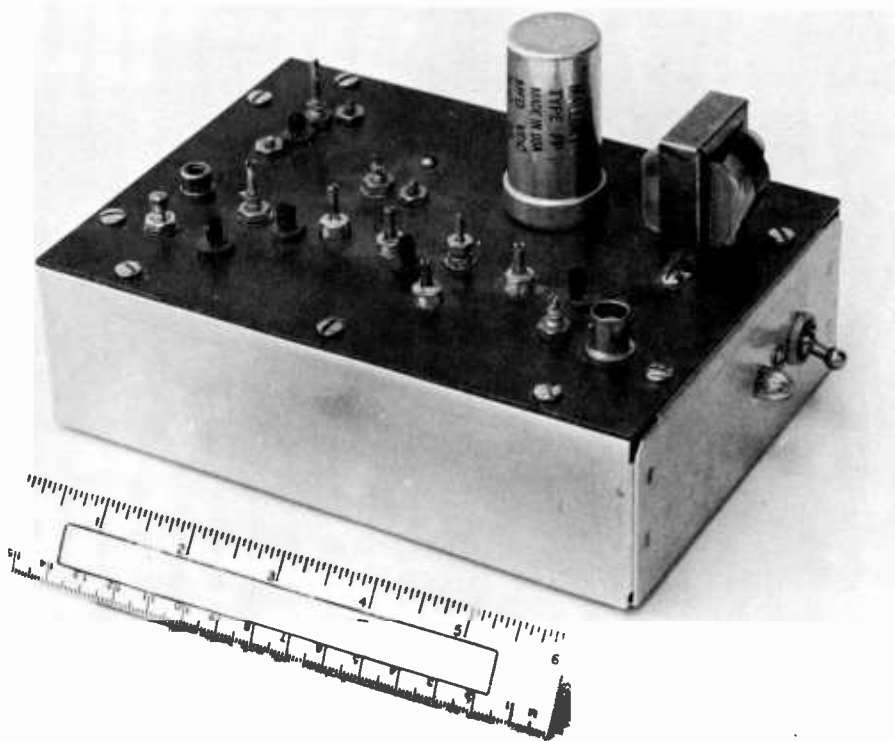

Figure 11

2-METER FET CONVERTER

This compact 144-MHz converter provides low noise reception and freedom from strong-signal overload at a modest price. Using four inexpensive FETs and one bipolar transistor, the converter shows a noise figure of 2.5 decibels.

Input receptacle J₁ is at the right of the deck, with neutralizing coil L, adjacent to it, and the r-f amplifier FET immediately behind it. Running to the left are the second r-f amplifier, the mixer and the auxiliary i-f amplifier, with output receptacle J₂ at the far left. To the rear of the assembly are the crystal-oscillator stage and the power supply. The power-line and neon-lamp indicator are mounted to the side of the aluminum chassis.

26-3 An FET Converter for 144 MHz

The field-effect transistor provides a low noise figure and effective overload capability in the vhf region and is well suited for use up to 450 MHz or higher. Described in this section is an excellent general-purpose converter (figure 11) for advanced 2-meter operation that makes use of inexpensive *Texas Instruments* field-effect transistors in common-source configuration. The converter is capable of a noise figure of 2.5 decibels or better, and the frequency

response is sufficiently broadband so that the complete 2-meter band may be covered without retuning the various interstage circuits of the converter. This converter was designed and built by WA6QIC.

The Converter Circuit The complete schematic of the converter and power supply is shown in figure 12.

Four FETs and one bipolar transistor are used, and the converter features a built-in power unit for operation from 115 volts, 50-60 hertz. Two TIS-34 FETs are used in a two-stage neutralized r-f amplifier chain which provides excellent noise figure and

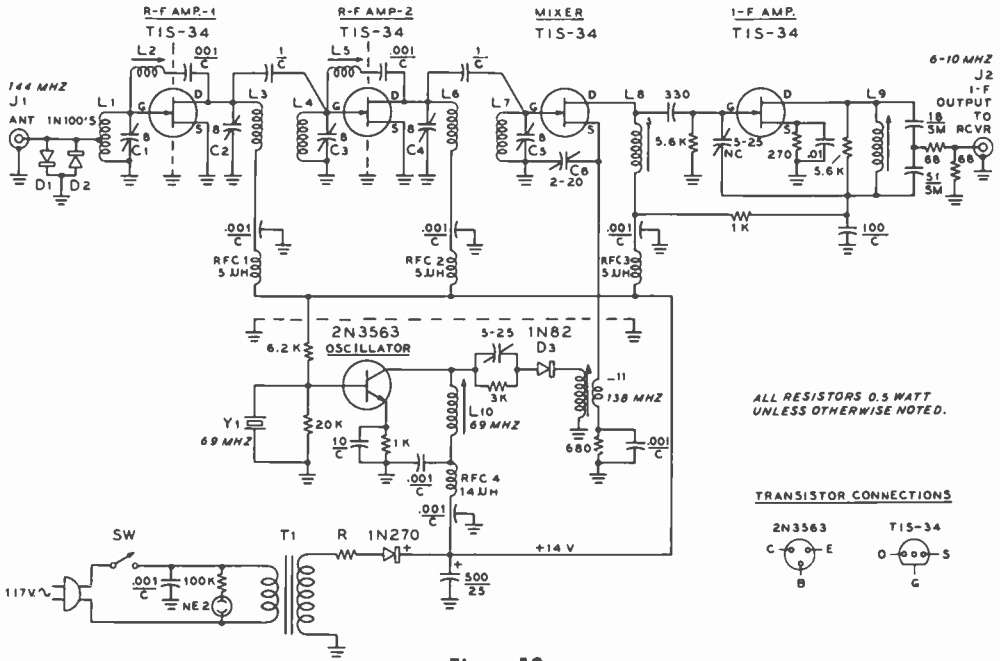

Figure 12

SCHEMATIC, 2-METER FET CONVERTER

- C_1, C_2 —8-pf piston capacitors (Centralab 829-10) or JFD-57G
- C_3 —20-pf mica compression trimmer. (El Menco 402)
- NC—25-pf ceramic (Centralab 827C)
- L_1 —4 turns #20 e., air-wound, $\frac{1}{2}$ " diam \times $\frac{3}{8}$ " long. Tap $\frac{1}{4}$ " turns from ground
- L_2, L_3 — $7\frac{1}{2}$ turns, $\frac{3}{16}$ " diam. on slug-tuned form. Spacing adjusted along with slug for neutralization. Approx. $0.6 \mu\text{H}$. (J. W. Miller 4300-4)
- L_4, L_5, L_6, L_7 —Same as L_2 , but no tap. Adjust spacing and tuning for optimum passband
- L_8, L_9 —Grid-dip to 8MHz (Approx. $40 \mu\text{H}$) (J. W. Miller 20A475-RB1)
- L_{10} —Grid-dip to 69 MHz. 7 turns #20 e. (J. W. Miller 4300-4)
- L_{11} —Grid-dip to 138 MHz. 4 turns, air-wound, $\frac{3}{16}$ " diam. \times $\frac{1}{2}$ " long. 2-turn link
- R—See text

good freedom from overload resulting from nearby strong signals. The input circuit of the converter is a conventional parallel-tuned tank, with the tapped antenna connection protected from excessive r-f input voltage by two back-to-back diodes. Each r-f amplifier stage is individually neutralized by a slug-tuned inductor placed from gate to drain, forming a parallel-resonant, high-impedance circuit in common with the feed-through capacitance of the FET and socket. The r-f stages are capacitively intercoupled, each stage having separately tuned input and output circuits.

It should be noted that no source bias is employed on the r-f stages since selected FETs are used. These transistors are chosen for lowest value of I_{DSS} , as described later,

affording optimum noise figure. Use of random FET's in the r-f stages requires that source bias be provided for each stage. The bias, if used, would consist of a 270-ohm resistor in series with the source-to-ground connection, shunted by a 120-pf disc ceramic capacitor.

A third selected TIS-34 FET is used as a mixer stage, with the incoming signal applied to the gate electrode and the local oscillator inductively coupled to the source circuit. The FET is biased so as to operate over the lower portion of the transfer curve for proper square-law detection and optimum large-signal overload capability.

The 2-meter FET converter is designed to be operated with a receiver tuning the 6 MHz- to 10-MHz i-f region, the local

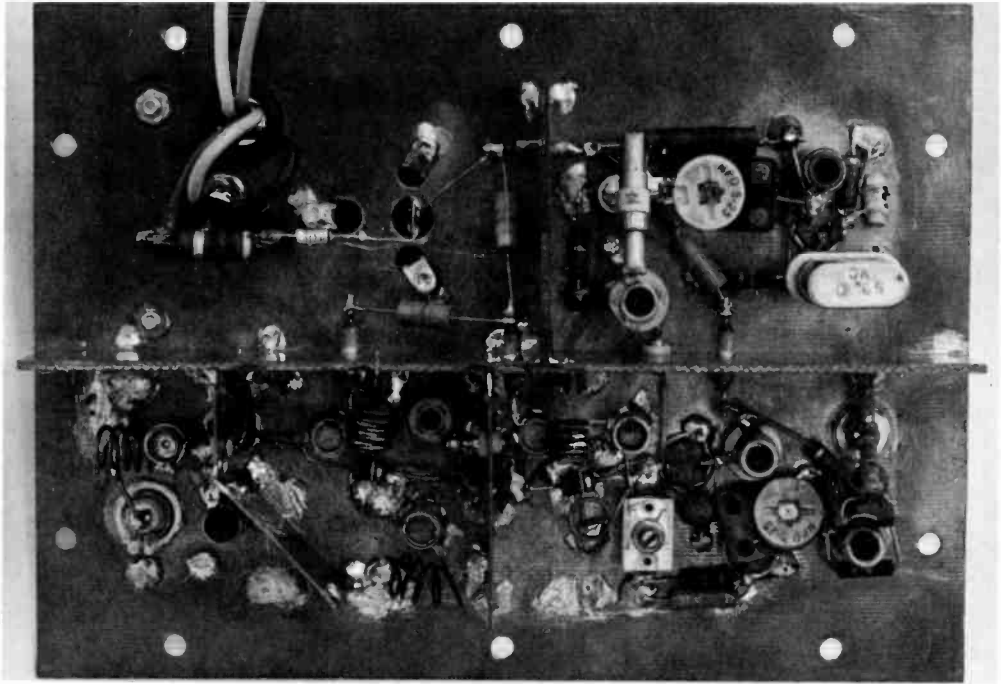

Figure 13

UNDER-CHASSIS VIEW OF 2-METER CONVERTER

The small components are soldered between each other or are soldered directly to the copper foil of the circuit board. The power supply and crystal oscillator are at the top of the photograph separated by a small vertical shield. The 69-MHz overtone crystal is mounted in the underchassis area, to the right of the multiplier diode and next to the adjustable series loading capacitor of the diode. The mixer and i-f amplifier are assembled directly below the oscillator. To the lower left are the two neutralized r-f stages. The antenna input circuit is to the left of the L-shaped shield which is mounted across the input transistor socket. The neutralizing coil is to the left of the bend of the shield. The center shield is placed across the socket of the second FET socket. At the lower right are the sink tuning capacitor (C_s) of the mixer and the neutralizing capacitor (NC) of the i-f amplifier stage.

oscillator inductively coupled to the source crystal and a varactor doubler to provide a 138-MHz injection signal. A 2N3563 serves as an overtone oscillator stage, followed by a diode multiplier (D_3) that provides ample injection voltage for the FET mixer stage.

I-f output is taken from the drain circuit of the mixer and is capacitively coupled to a TIS-34 FET i-f amplifier. The i-f stage is broadbanded for optimum response across the 4-MHz i-f channel and is neutralized for circuit stability. Incorporation of the i-f amplifier ensures that the excellent noise figure of the converter is not degraded by the noise figure of the receiver. A simple voltage-divider network is included in the

output circuit of the converter to permit the FET i-f amplifier to operate into a resistive load at all times, regardless of the input circuitry of the receiver used as an i-f channel.

The integral power supply provides 14 volts d.c. from a half-wave rectifier for converter operation. Supply voltage may, however, be taken from the station receiver or from a car battery for mobile operation. Converter current drain is about 35 milliamperes.

Selecting the FETs Field-effect transistors have a wide range of conductance which is specified in terms of drain current, measured when the gate is connected

to the source (I_{DSS}). In the case of the TIS-34, limits of 5 ma to 20 ma are specified for I_{DSS} . FETs having low values of I_{DSS} have lower conductance but exhibit a superior noise figure, and the FET having the lowest value of I_{DSS} should be used in the first r-f amplifier stage. The FETs may be bench-tested without damage before they are placed in the converter. Each FET has +9 volts applied to the drain through a low-range d-c milliammeter, with gate and source electrodes connected to the -9 volt supply. A FET having a measured I_{DSS} current of 7 milliamperes or less should be chosen for the first r-f stage, with the next lowest measured FET placed in the second r-f stage. If no FET is found having an I_{DSS} figure of 7 milliamperes or less, the lowest measured unit may be used in conjunction with sufficient source resistance bias (suitably bypassed) to limit the drain current to about 5 milliamperes.

The FET having the *highest* value of I_{DSS} should be used for the mixer stage. The source bias resistor (shown to be 680 ohms in the schematic) may vary between 500 and 1200 ohms, and should be selected to set the drain current to one-quarter of the no-bias I_{DSS} current value.

The few minutes spent in selecting the FETs and the mixer bias resistor for optimum circuit performance will provide the best possible noise figure consistent with maximum converter strong-signal overload capability.

Converter Construction The converter is built upon a sheet of copper-plated circuit board measuring 5" \times 7" in size. This is placed atop an inverted aluminum chassis of the same dimensions and 2" deep which acts as a base and dust shield. Layout of the major components are shown in the under-chassis photograph (figure 13).

A shield made of circuit board material measuring 7" \times 1 $\frac{1}{4}$ " in size is run down the center of the board and soldered in place. The power supply and crystal oscillator are located on one side of this shield and the various r-f, mixer, and i-f stages are placed on the opposite side. Two small 2" shields are placed at right angles to the larger one: the first shield separating the oscillator stage from the power supply, the

second shield fitted across the FET socket of the second r-f amplifier stage. The width of the crystal oscillator area is 3" and the width of the r-f stage area adjacent to it is 3 $\frac{1}{2}$ ". A third small 2" L-shaped shield is placed across the socket of the first FET r-f amplifier, about 2" to the side of the interstage shield. This shield has a bend in it to clear the neutralizing coil (L_2). Small .001- μ fd ceramic feedthrough capacitors are mounted in the various shields to permit the d-c operating voltage to pass between stages. A miniature feedthrough insulator is placed in the main longitudinal shield to pass the coupling wire running from multiplier coil L_{11} to the sink connection of the FET mixer socket. The secondary winding of coil L_{11} is tuned by a variable mica compression capacitor (C_6) placed directly at the socket of the FET mixer. Other components and coils are grouped about their respective stages to ensure short direct leads.

Converter Adjustment Once the converter is completed, the wiring should be checked against the circuit diagram for possible errors before the FETs are inserted in the sockets or power applied to the unit. The first step is to test the power supply and adjust the series resistor (R) for a supply potential of 14 volts under a load of about 35 milliamperes. The 2N3563 transistor and 69-MHz crystal are now inserted in their respective sockets and collector coil L_{10} is adjusted for oscillation. It may be necessary to alter the value of the emitter bypass capacitor (10 pf) to obtain reliable oscillation. As a starter, a 35-pf variable mica compression capacitor may be used until the optimum value of capacitance is determined.

Next, the r-f circuits are resonated to 145 MHz or so with the aid of a grid-dip oscillator. The i-f circuits (L_8 and L_9) in turn, are grid-dipped to 8 MHz, the center of the i-f passband. The field-effect transistors may now be placed in their sockets and power applied. The converter is connected to the receiver to be used for the i-f strip, and the latter is tuned to 8 MHz. If the converter is functioning properly, strong local 2-meter signals, or a nearby signal generator should be heard when an



Figure 14

FET CONVERTER FOR 432 MHz

This converter has been used for extensive moonbounce communication in conjunction with the antenna-mounted FET preamplifier described in this section. The converter is built on a deck of copper-plated, phenolic circuit board and operates from a 12-volt supply. The frequency is controlled by a 51.35 MHz overtone crystal. To reduce frequency drift as a function of temperature, the crystal is mounted in the small can at the rear, made from a holder for 35-mm film. The crystal is surrounded by strips of foamed-plastic packing material to reduce temperature excursions. The antenna receptacle is in the left corner and the i-f output receptacle is in the foreground. The converter deck is supported on a small inverted aluminum chassis used for a dust cover.

antenna is connected to the converter and the i-f receiver tuned across the passband. Preliminary alignment is accomplished by tuning all r-f circuits for maximum signal strength, as read on the S meter of the receiver.

Once it is determined that the unit is operating, the converter should be adjusted for proper bandpass and best noise figure. Adjustment of the first r-f stage (including neutralization) and local-oscillator in-

jection are the prime factors in determining noise figure. The second r-f stage and the i-f amplifier are adjusted for optimum passband characteristics. If sufficient time is taken, the converter passband can encompass the whole 4-MHz region of the 2-meter band. It will be found that a 2-MHz passband is easily obtained, but considerably more time will be spent "tweaking" adjustments to achieve the full passband of 4-MHz.

Tuning and neutralizing adjustments are undertaken to provide satisfactory gain while maintaining the optimum noise figure. It should easily be possible to hear antenna noise with this converter and adjustment is best done with a noise generator or a weak signal source.

The first step is to properly adjust the level of mixer injection from the local oscillator. With the converter in operation, the d-c source current of the FET mixer is measured by placing a low-range milliammeter in the ground return of the source bias resistor. It will be remembered that the bias resistor was chosen to limit the I_{DSS} current to one-quarter of the no-bias value of the chosen FET. Now, oscillator injection is adjusted by means of the series variable capacitor and the tuning of coil L_{11} until the source current increases to about one-half the original no-bias I_{DSS} value. For example, if I_{DSS} was found to be 16 ma, the mixer source resistor was chosen to provide a static value of source current of 4 milliamperes. Oscillator injection is therefore adjusted until the operating current is increased to 8 milliamperes.

The next step is to neutralize the r-f and i-f stages to achieve optimum noise figure. This may be done with a noise generator or weak signal. The proper point of neutralization will be found to be the point of maximum stage gain. This may be checked after neutralization by varying the supply voltage of the stages in question. As the voltage is either increased or decreased, the stage gain will drop if the stage is properly neutralized.

26-4 An FET Converter and R-F Amplifier for 432 MHz

Various inexpensive field-effect transistors (FETs) will perform well as r-f amplifiers far into the vhf spectrum when used in conjunction with a low-noise mixer stage. The converter and r-f amplifier described in this section uses 2N4416 field-effect transistors and provides excellent results at 432 MHz. The units were designed and built by K6MYC for "moonbounce" operation and the low-noise FET r-f amplifier is

mounted at the feed point of a remote, high-gain antenna system. The combination of converter and remote r-f amplifier provide a superior noise figure and overcome the troublesome problem of line loss that can degrade small-signal reception at this frequency.

The FET converter described herewith (figure 14) provides a noise figure of about 5 decibels, mostly determined by mixer noise. The r-f stage gain is about 10 decibels, but this is not sufficient to completely override mixer noise. Addition of the second remote r-f amplifier stage at the receiving antenna brings the over-all noise figure of the combination down to 3 decibels, or better.

The FET converter may be used by itself except for the most serious low-noise reception, when the addition of a remote r-f amplifier stage ahead of the converter unit becomes a necessity. The operational flexibility afforded by the use of a separate r-f amplifier cannot be overemphasized, since it permits the user to modify the system when the availability of new and better transistors or FET devices allow superior noise figure to be achieved as the state of the art advances. Some present bipolar transistors provide slightly superior noise figure at 432 MHz than that of the FET devices used; however, the problem of receiver overload from local signals or radar is ever present at 432 MHz and the use of FET's is highly recommended for the serious vhf operator.

Converter Circuitry The schematic of the 432-MHz FET converter is shown in figure 15. A 2N4416 FET is used in a neutralized common-source configuration as a strip-line r-f amplifier. This stage is followed by an inductively coupled 2N4416 as a common-source strip-line mixer stage. Both local oscillator and received signal are mixed in the gate circuit of the FET and the resulting i-f signal is taken from the drain circuit.

The local-oscillator chain is an integral part of the converter, using a 51.35-MHz fifth-overtone crystal oscillator and harmonic multipliers to generate a 410.8-MHz mixing signal. The intermediate frequency for 432-MHz reception, then, is 21.2 MHz.

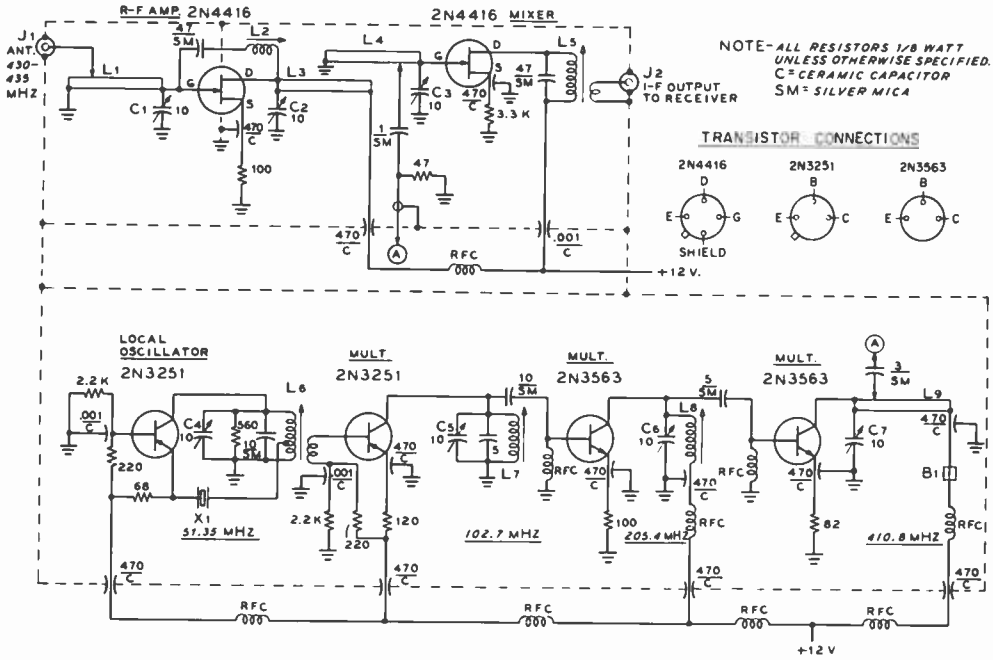

Figure 15

SCHEMATIC, 432-MHz FET CONVERTER

- C₁, C₂, C₃, C₄—10-pf ceramic piston-type capacitor. (JFD 57G or Centralab 829-10)
- C₅—10-pf capacitor (Johnson 160-107 or equiv.)
- L₁—Copper strap, 1/4" wide X 1 1/4" long with 5/16" foot at ground end, Silver plated. Grid-dip to 432 MHz
- L₂—4 turns #22 e. on 3/16" slug-tuned form (J. W. Miller 4300-7, blue)
- L₃—Copper strap, 1/4" wide X 2" long. Supported at "cold" end by feedthrough capacitor. Silver plated. Grid-dip to 432 MHz
- L₄—Same as L₃. Tap 1-pf capacitor at approx. midpoint of line. Adjust tap for best noise figure. Grid-dip to 432 MHz
- L₅—Tune to 21.2 MHz. 15 turns #22 e. on 1/4" form. (J. W. Miller 4500-6, purple). Two-turn link made of hookup wire
- L₆—8 turns #20 e., 1/8" diam. X 3/4" long. Tap 2 3/4 turns from ground end. (J. W. Miller 4400-3, green). Two-turn link made of hookup wire. Grid-dip to 51.35 MHz
- L₇—4 turns #20 e., 5/16" diam. air-wound, 1/4" long. Grid-dip to 102.7 MHz
- L₈—2 1/2 turns #20 e., 5/16" diam. air-wound, 1/2" long. Grid-dip to 205.4 MHz
- L₉—Same as L₈. 1 1/4" long. Grid-dip to 410.8 MHz
- RFC—5 μH (J. W. Miller 9340-14, or equiv.)
- J₁, J₂—Coaxial receptacles, BNC type UG-625/U
- B₁—Ferrite bead. Stackpole 7D (57-0180)
- X₁—Crystal, 51.35 MHz, type HC-6/U

Bipolar transistors are used in the local-oscillator chain, two 2N3251 transistors serving as oscillator and frequency multiplier to 102.7 MHz, followed by two 2N3563 multiplier stages to 205.4 MHz and 410.8 MHz, respectively. The mixing signal is capacitively coupled to the 2N4416 FET mixer stage and oscillator coupling is adjustable to provide optimum mixer noise figure. While the converter is normally used for spot-frequency operation near 432 MHz,

the tuned circuits are sufficiently broad so as to permit good reception one or two MHz removed from the frequency of adjustment, without further tuning of the converter.

Converter Construction The 432-MHz FET converter is constructed on a piece of copper-clad glass epoxy circuit board measuring 5" X 7". A matching shield case is made of an aluminum chassis of the same dimensions and 1 1/2" deep.

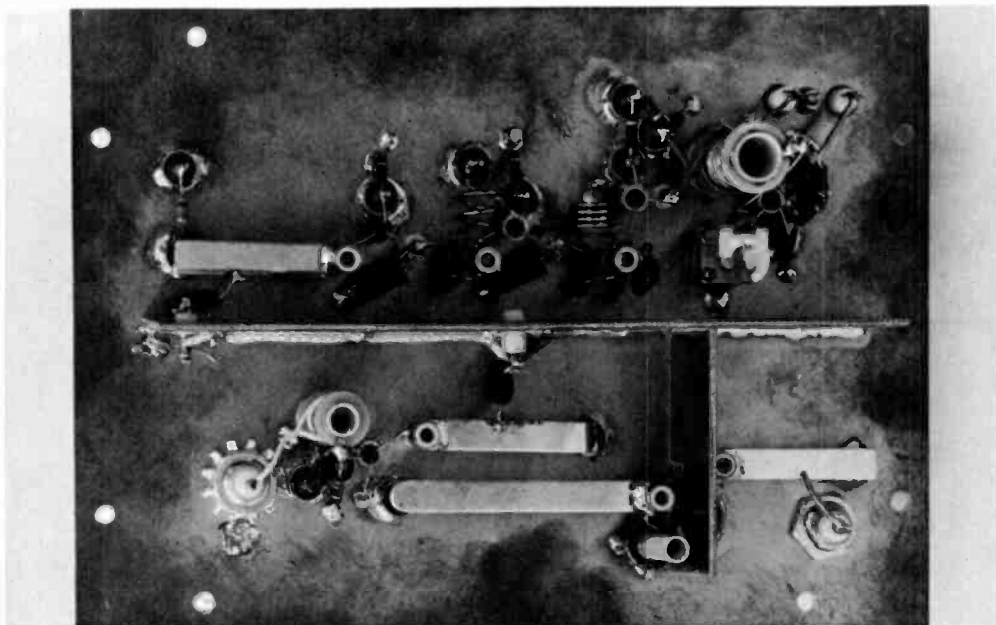

Figure 16

UNDER-CHASSIS VIEW OF CONVERTER

Placement of components may be compared with the layout drawing of figure 17. Interstage shields are made of strips of circuit-board material. Local-oscillator chain is at top of chassis with the crystal socket at the right. Antenna receptacle J_1 is at lower right, with i-f output receptacle J_2 at lower left. Transistors and FET's are mounted in an inverted position by their leads.

Placement of the major components may be seen in the photographs of figures 14 and 16 and layout drawing of figure 17.

A shield plate measuring $1'' \times 6''$ is cut from circuit-board material and soldered along the center line of the converter, with a second shield measuring $1'' \times 2''$ placed across the r-f amplifier transistor to reduce intrastage coupling and to permit proper neutralization. A small opening is cut in the lower edge of the shield and the 2N4416 r-f transistor is placed in the opening, supported from the shield plate by soldering the shield lead of the transistor to the plate. The various other transistor leads go directly to the associated components, no sockets being used in the construction of the converter.

All parts should be laid out on the circuit board in a preliminary mockup before holes are drilled and assembly started. The quarter-wavelength strip-line circuits are fabri-

cated first, since these determine the placement of other parts and the positioning of the FETs. The lines are made of short lengths of $\frac{1}{4}$ -inch wide silver-plated copper strap, and are mounted $\frac{5}{16}''$ above the circuit board. Lines L_1 and L_4 are grounded directly to the copper foil of the board and lines L_3 and L_6 are supported by means of silver-mica "button" feedthrough capacitors. The lines are supported at their high-impedance ends by piston-style tuning capacitors mounted to the circuit board.

The r-f stage neutralizing coil (L_2) is mounted in a vertical position adjacent to the intrastage shield, one terminal of the coil being soldered to the junction of capacitor C_2 and strip line L_3 and the other terminal lead passing through a small hole in the shield to terminate at the 47-pf silver-mica coupling capacitor. This, in turn, is soldered to the barrel of piston capacitor C_1 . The slug of coil L_2 may be adjusted

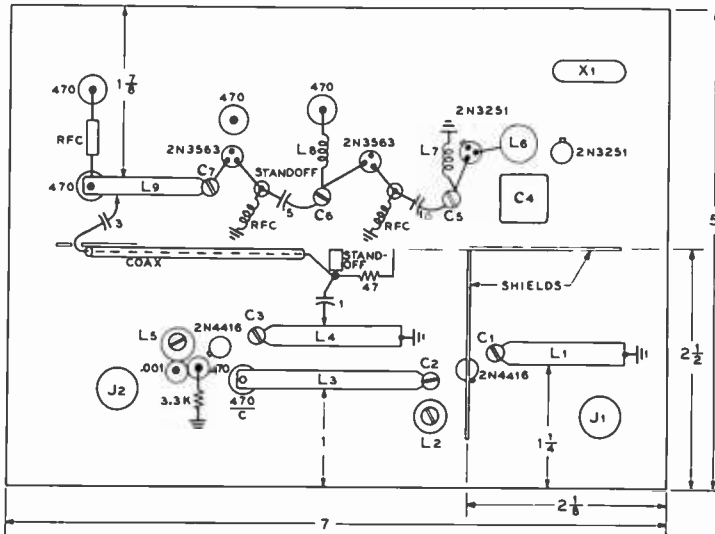

Figure 17

COMPONENT LAYOUT FOR 432 MHz CONVERTER

Tuned circuits are grid-dipped to resonance before FETs and transistors are soldered in place.

through a hole drilled in the surface of the circuit board.

All components in the r-f amplifier and mixer stages are grouped closely about the transistors which are supported by their leads in an inverted position. The positioning of strip lines L_3 and L_4 determine the coupling between the r-f amplifier and the mixer. Coupling is not critical, and an edge-to-edge spacing of $\frac{1}{4}$ " is satisfactory. The outer edge of strip line L_3 is located one inch away from the edge of the circuit board.

The local-oscillator chain is placed on the opposite of the center shield partition, with the 410.8-MHz strip-line circuit placed about $1\frac{7}{8}$ " away from the edge of the circuit board, as shown in the layout drawing. The mixing signal is coupled through a 3-pf capacitor into a short length of miniature coaxial line which runs along the center shield back to a position near strip line L_1 , at which point the line is coupled to the mixer stage through a 1-pf capacitor. The coaxial line is made up of a short length of Teflon insulated wire run through a small flexible copper braid. The braid is soldered to the partition and terminated at a small standoff insulator mounted on the partition

in the vicinity of strip line L_1 . Oscillator-chain wiring is conventional, the components being supported by their leads and several midget Teflon standoff insulators, as shown in the layout drawing.

Testing the Converter Upon completion, the wiring should be checked against the schematic diagram. Before the transistors are wired in place, it is suggested that the various tuned circuits be grid-dipped to the operating frequencies with the aid of a vhf grid-dip oscillator. Once the circuits are in approximate resonance, the transistors may be wired in the circuit. In order to prevent damage to the transistors, it is recommended that the transistor lead be grasped with long-nose pliers between the body of the transistor and the joint, the pliers acting in the manner of a heat sink, preventing the transistor element from being damaged by the heat of soldering. The transistors are mounted in an inverted position in each case, with the leads trimmed to about $\frac{1}{4}$ " length.

Converter adjustment follows the procedure outlined for the previously discussed units. The local-oscillator chain may be monitored in a nearby receiver for proper

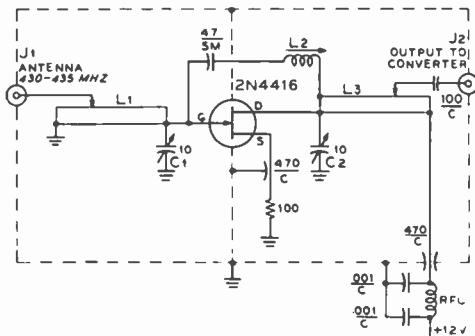

Figure 18

SCHEMATIC 432-MHz REMOTE R-F AMPLIFIER

Tuned circuits and components are the same as listed for r-f amplifier of figure 15.

crystal operation. As the tuned circuits are near resonance, it is possible to peak the circuits on a local signal, while monitoring the output signal in the receiver used as an i-f strip. Preliminary alignment may be accomplished by peaking all circuits to achieve maximum signal strength.

Once the circuits are in close alignment, the converter should be adjusted for best noise figure. The various tuned circuits, including the neutralizing circuit of the r-f amplifier are all adjusted with this end view in mind. The adjustments are best accomplished with the aid of a noise generator to achieve lowest internal noise consistent with optimum gain. One accurate but time-consuming neutralization technique is to inject a 432-MHz signal into the drain circuit of the amplifier and monitor the signal in the input (gate) circuit with an auxiliary receiver. A low-level signal from a tone-modulated signal generator is coupled by a coaxial line into tuned circuit C_3 - L_4 . The auxiliary receiver, or converter, is coupled to the input circuit through receptacle J_1 and the tone-modulated signal monitored. The strip lines are peaked for maximum signal transfer, and the neutralizing coil (L_2) adjusted for minimum signal transfer.

Lacking a second 432-MHz receiver, another neutralizing technique is practical and somewhat quicker than the one outlined above. The converter is tuned for best noise figure with the aid of a noise meter, and system gain is then observed as the supply voltage to the r-f stage is varied from

that value at which the stage was previously neutralized. When the drain voltage is varied, the reverse transfer capacitance (drain-to-gate feedback capacitance) is varied as a first-order effect. Thus, if it is found that stage gain increases as the drain voltage is increased or decreased, it is an indication that the stage is improperly neutralized. When neutralization is achieved, any change in drain voltage will result in a decrease in stage gain.

A final check on neutralization may be made by operating the converter with the input circuit short-circuited and open-circuited. The converter should remain stable under these conditions, without signs of regeneration, or "burbles" heard in the i-f strip receiver. The final check, of course, is determined by proper converter operation on weak signals, and the neutralization adjustment should be considered just one of several tools used to achieve lowest noise figure.

Frequency Stability After a period of use it was found that the received frequency drifted a sufficient amount with change of temperature so as to make very narrow-band c-w reception difficult. Satisfactory frequency stability was achieved by placing the local oscillator crystal in a metal can made from a 35-mm film holder. The can was stuffed with strips of foamed fiberglass type material to reduce temperature excursions. The crystal was thus sufficiently insulated from rapid temperature changes so as to permit good short-term stability necessary for serious c-w and SSB reception.

The Remote R-F Amplifier It was decided to place a second r-f amplifier at the receiving antenna to overcome transmission-line loss and improve reception. The schematic of the amplifier used is shown in figure 18. Essentially, this amplifier is a duplicate of the one used in the 432-MHz converter and is built in a small double-compartment brass box measuring 2" \times 3" \times 1" in size. A brass shield is soldered across the center of the box and the FET is mounted in a small hole cut in the shield. The transistor may be easily removed and another one substituted in order to achieve the best possible noise figure. The

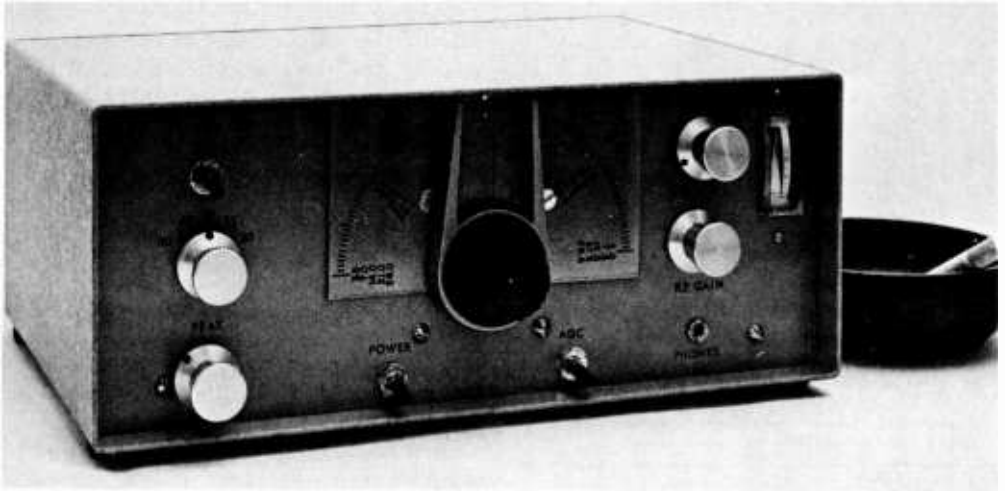

Figure 19

A SOLID-STATE AMATEUR BAND RECEIVER

This advanced communication receiver covers all amateur bands between 80 and 10 meters. It uses 3 MOSFETs, 5 FETs, 5 transistors, 2 ICs, and 3 hot carrier diodes. Measuring only 10" × 4" (panel size) and 7" deep, the solid-state receiver provides excellent reception of SSB and c-w signals, combined with exceptional strong signal overload capability.

Panel controls (l. to r.) are: Sideband selector switch (S₁); bandswitch; peak preselector (C₁); power switch (S₂); AGC switch (S₃); phone jack (J₁), insulated from the panel; r-f gain potentiometer (R₁); audio gain control (R₂); and signal-strength meter (M).

The main tuning dial is calibrated every 100 KHz, with 5-kHz markers and is made of a panel mask (figure 28). The pointer window is cut from a piece of 1/4-inch aluminum stock and has a plastic window insert epoxied to the underside of the frame. The cursor line is scratched on the rear of the window.

+12-volt supply is run from the station to the antenna by a separate power lead, although the voltage may be coupled to the r-f amplifier via the center conductor of the coaxial line, if desired.

Use of a separate r-f amplifier, even if located at the operating position, is a great advantage at 432 MHz since experimental units may be built and tested without the necessity of disrupting the station receiver. As newer and better FET's and transistors appear, they may readily and easily be tested for operation in simple r-f amplifier "black boxes" built especially for transistor evaluation.

26-5 A Solid-State Amateur Band Receiver

The introduction of the field-effect transistor and the integrated circuit makes

feasible the design of a compact, completely solid-state amateur band receiver for c-w and SSB reception that performs as well as or better than an equivalent receiver using conventional vacuum tubes. The advanced receiver described in this section (figure 19) is completely solid state, making use of improved MOSFET and IC devices, and covers the amateur bands between 80 and 10 meters in 500-kHz segments. The design goal was to produce a compact receiver of top-notch performance, but one not so small as to be difficult to assemble and wire, or to operate. For easy duplication, all components used in construction of the receiver are "off-the-shelf" items readily obtainable from the larger radio parts distributors. The receiver may be run from a battery power supply or from an a-c supply so it is well suited for either mobile or fixed service. This receiver was designed and built by VE3GFN.

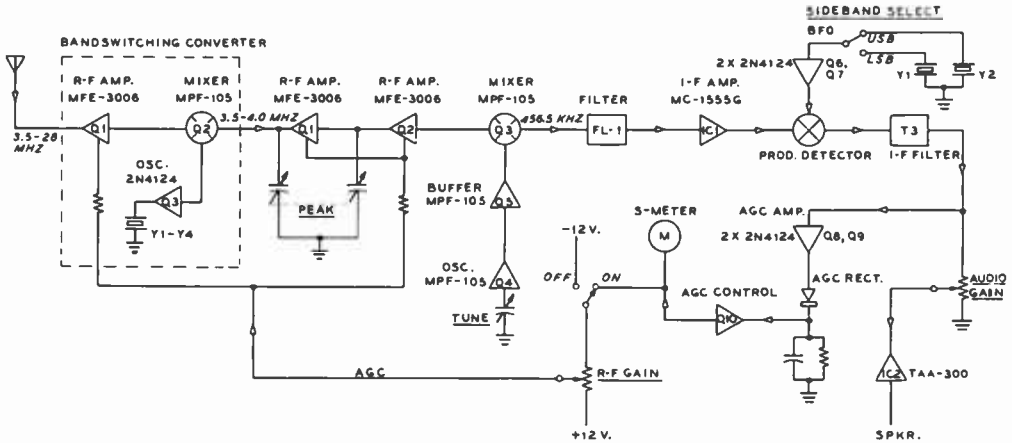

Figure 20

BLOCK DIAGRAM OF THE SOLID-STATE COMMUNICATION RECEIVER

The main portion of the receiver covers the 80-meter band (3.5-4.0 MHz) and serves as an i-f section for a bandswitching converter covering the 40-, 20-, 15-, and 10-meter bands in 500-kHz segments. The high-frequency converter unit is crystal controlled and the low-frequency variable oscillator in the 80-meter section is not switched, permitting a high degree of electrical and mechanical stability to be achieved. I-f gain is provided by an integrated circuit module (MC-1555G) and suitable 5SB selectivity is achieved by a mechanical filter. Audio agc is provided for the various r-f stages and front-end gain may be separately controlled, if desired. The complete schematic of the receiver is given in Figures 21 and 23.

The Receiver Circuit A block diagram of the complete solid-state receiver is shown in figure 20. The circuit is basically a four-band crystal-controlled front-end converter, followed by a tunable i-f receiver which covers the fifth band (80 meters). The bandswitching front-end, or converter, is shown in detail in figure 21. This separate assembly covers the amateur bands between 7 MHz and 29 MHz, with allowance in design for out-of-band coverage, as well as coverage as high as 30 MHz, or more. Using a *Motorola* MFE-3006 high-frequency MOSFET device in the tunable r-f amplifier stages results in high gain and good circuit stability. The r-f amplifier circuitry does not require neutralization, while permitting AGC (automatic-gain-control) voltage to be applied to the front end, a feature very necessary in solid-state receivers. The dual-gate feature of the MFE-3006 allows a separation of these functions, the incoming signal being applied to gate 1 of the MOSFET and the agc control voltage to gate 2 of the device.

Laboratory measurements taken on the receiver provide the following data on performance. *Sensitivity*: Less than 1 microvolt for a 10-decibel signal-plus-noise to noise ratio on all bands. *Image ratio*: Better than 60 decibels on all bands, and as high as 80 decibels. *Drift*: Less than 100 Hz per hour at receiver temperature of 70°F. *Spurious Responses*: Oscillator harmonics noted at 7.0 MHz and 21.250 MHz.

The R-F Section—The tuned circuits in the high-frequency portion of the receiver are basically 20-meter circuits, which are made resonant in the other high-frequency bands by means of appropriate shunt impedances brought into the circuit by the bandswitch. For 40-meter operation, the basic tuned circuit is padded to a lower resonant frequency by means of capacitor C₁ (figure 22). For 15- and 10-meter operation, the inductance of the tuned circuit is shunted by parallel inductors (L₂ and L₃) thus effectively raising the resonant frequency of the new circuit formed by the auxiliary inductors. These tuned circuits are

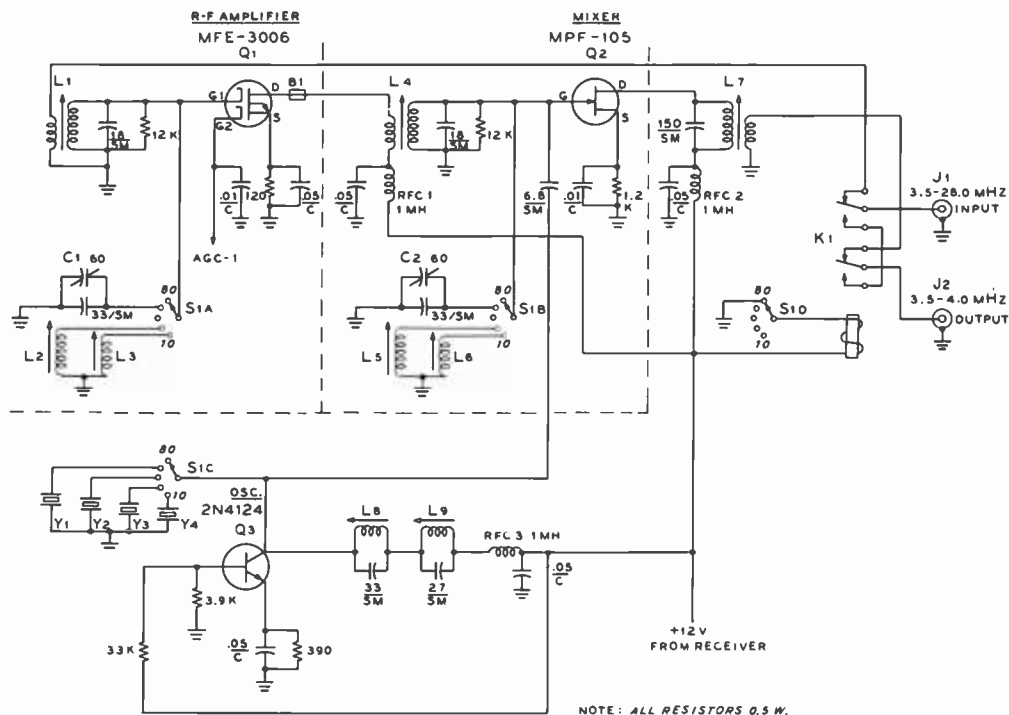

Figure 21

CONVERTER PORTION OF COMMUNICATION RECEIVER

B₁—Ceramic bead (Ferroxcube K5-001-03B or Stackpole 7D)

C₁, C₂—10 to 60-pf piston capacitors (Voltronics TM-60C, or equiv.)

J₁, J₂—Type BNC receptacles, UG-657/U

K₁—Dpdt relay, crystal-can style, 12-volt coil (Potter-Brumfield SC-11DB or equiv.)

L₁, L₂—24 turns #32 enameled wire, closewound on 1/4" diameter form. Approx. 4 μH (Q = 50).
Use J. W. Miller 4500-2 (red) form, powdered iron core. Link winding is 5 turns #42 e. around "cold" end of coil

L₃, L₄—(15 meters). 20 turns #32 e., closewound on 1/4" diam. form. Approx. 3.4 μH. J. W. Miller 4500-3 (green) form, powdered-iron core

L₅, L₆—(10 meters). 11 turns #32 e., as L₃. Approx. 1.4 μH

L₇—40 turns #32 e., closewound on 1/4" diameter form. J. W. Miller 4500-3 (green) form, powdered iron core. Tunes to 3.9 MHz. Link winding is 10 turns #32 e. around "cold" end of coil

L₈—10 turns #32 e., closewound on 1/4" diameter form. J. W. Miller 4500-2 (red) form, powdered iron core. Resonates to 24.5 MHz.

L₉—15 turns #32 e., as L₈. Resonates to 17.5 MHz

RFC₁₋₃—1 millihenry. J. W. Miller 9350-44 or equiv.

S_{1A-1}—4 pole, 6 position ceramic switch. Centralab 2021 or equiv.

Y₁—3.500 MHz crystal, HC-6/U holder

Y₂—10.500 MHz, as Y₁

Y₃—17.500 MHz, as Y₁

Y₄—24.500 MHz, as Y₁

designed to have an essentially flat response over 500 kHz of the band in use, making a peaking control unnecessary. The 10-meter tuned circuits can be adjusted to pass any 500-kHz segment of the 10-meter band, allowing the receiver to cover the complete band, by the proper choice of local-oscillator

conversion crystal and auxiliary inductor tuning.

Maximum gain is obtained from the MOSFETs in the r-f amplifier stages when gate 2 has +12 volts applied to it; however, this amount of gain has a tendency to overload the i-f system on any strong

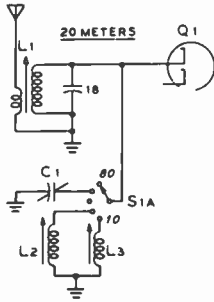

Figure 22

SIMPLIFIED R-F SWITCHING CIRCUIT

The external antenna is coupled to a resonant LC circuit for 20-meter reception. When the bandswitch is changed to 40 meters, the 20-meter circuit is padded to the lower frequency by the addition of piston capacitor C_1 , placed in the circuit by switch section S_{1A} . On 15 meters, the inductance of 20-meter coil L_1 is decreased by the added shunting action of coil L_2 . On 10 meters, coil L_1 is switched in the circuit. Alignment of the tuned circuit must first be done on 20 meters before the 15- and 20-meter bands are adjusted.

signal. Hence, provision has been made in the design of the agc system to limit the positive swing of the front-end agc input, eliminating this problem.

The Mixer-Oscillator—A 2N5459 (MPF-105) FET is used as a common-source mixer with local oscillator and received signals applied to the gate element. The crystal-controlled local oscillator is capacitively coupled to the gate and the incoming signal is inductively coupled through transformer L_4 . The converter oscillator employs a 2N4124 bipolar transistor and uses an r-f choke as a broadband collector load on the lower frequencies (RFC₃). Series-connected, parallel-tuned circuits provide properly selective collector loads on the two higher-frequency bands. These circuits exhibit little effect except when excited by the crystal frequency to which they are resonant. The use of tuned collector-load circuits is particularly necessary above 20 MHz or so where the common practice is to employ overtone crystals.

The schematic of the tunable 80-meter stages and low-frequency i-f section is shown in figure 23. The front end of this section of the receiver has two stages of r-f amplification using MFE-3006 MOSFETs to provide needed sensitivity and image rejection. The tuned circuits for these stages are adjustable from the panel of the receiver and provide a preselector function (PEAK). Good electrical isolation between the stages is necessary as the gain of this cascade circuitry is considerable. To avoid cross modulation and overload, these stages are followed by an MPF-105 FET mixer (Q_3), using a common-gate circuit proven to be tolerant of high input levels.

The intermediate frequency of the receiver is 455 kHz and the frequency response of

the i-f system is largely established by a mechanical filter having a passband (2.1 kHz) suitable for SSB reception. Intermediate-frequency gain is provided by a Motorola integrated circuit element (MC-1553G), matched to the mechanical filter by a simple transformer and resistance network.

The Product Detector—A product detector is used to provide good linearity, low insertion loss, and a minimum of beat-oscillator leakthrough into the audio system. One-half of a diode quad is used for the detector, employing 1N2970 hot-carrier diodes, resulting in excellent circuit balance. Closely matched 1K load resistors ensure minimum leakthrough while a simple low-pass audio filter (T_3) placed after the product detector attenuates all residual high-frequency products. The filter is a parallel-tuned circuit at 455 kHz offering high impedance to the intermediate frequency, and a low impedance to audio frequencies.

The local oscillator (bfo) consists of separate crystal-controlled oscillators with the outputs selected by switch S_2 , feeding the input of the product detector through transformer T_2 . A switch on the panel of the receiver (SIDE BAND SELECT) turns on one oscillator or the other for upper- or lower-sideband reception. The specified oscillator crystals should be as close to the target frequency as possible, since reduced detector output will result if one or the other of the crystals is misplaced on the slope of the filter passband. Product-detector attenuation is only about 6 decibels, which provides an audio output of nearly 10 millivolts with a 20-millivolt peak i-f signal input. Linearity of the i-f circuit and detector stages is excellent, input signals up to 300 millivolts or so being attained before distortion products in the audio signal are

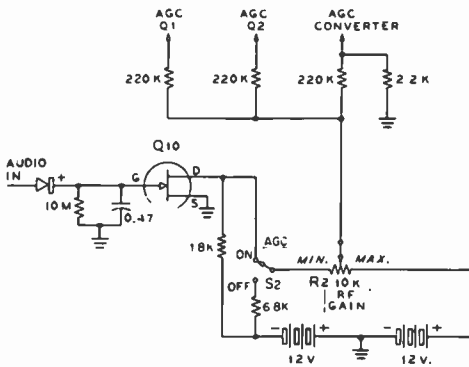

Figure 24

SIMPLIFIED AUDIO-CONTROLLED AGC SYSTEM

The three agc lines (Q_1 , Q_2 , and converter) are terminated at the arm of r-f gain control R_2 . When agc switch S_1 is off, control voltage may be varied between +12 and -3 volts. When the agc system is on, control is switched to the drain circuit of FET Q_{10} . Agc voltage is now proportional to the audio input signal, varying between zero and +12 volts under normal conditions. A strong signal will drive the agc towards -12 volts, sharply reducing receiver gain. Maximum gain is controlled by the potentiometer.

evident to the ear.

The audio system is a second integrated-circuit package (TAA-300) delivering almost a watt of audio power with a 10-millivolt driving signal. Speakers of 3 to 30 ohms impedance may be used, and the receiver will drive an efficient 10-inch diameter speaker with impressive results. A jack is provided on the panel for use with low-impedance earphones.

The AGC System—The agc network is novel in that the agc lines swing from positive to negative potential with increasing input signal level (figure 24). The three control lines are terminated at the arm of the R-F GAIN control potentiometer (R_2). One end of the potentiometer (max) is connected to the +12-volt supply line, and the other end (min) to about -3 volts when the agc switch (S_2) is off. When agc is on, the control is switched to the drain circuit of an agc control FET (Q_{10}). With no input signal, the gate of the control FET is near zero potential and the FET conducts, placing the negative end of the r-f gain control potentiometer close to ground potential. The

agc lines, therefore, are at some positive potential between ground and +12 volts, depending on the setting of the potentiometer, allowing maximum receiver gain to be established, if desired. When a higher input signal level requires reduced front-end receiver gain, rectified audio of a positive polarity from the agc amplifiers (Q_8 , Q_9) is applied to the gate of the control FET, reducing its conduction. Accordingly, the drain element of the FET drops toward -12 volts, taking the agc lines along with it, thus reducing front-end gain of the receiver.

The gate element of the control FET is connected to an RC circuit having a long time constant, which prevents gate voltage from changing too rapidly between c-w characteristics or between spoken syllables of an SSB signal. This circuit is designed to charge quickly when the receiver power is first applied, so that front-end gain is minimum. A diode across a portion of the time-constant circuit leaks off this charge in less than a minute, and the action can be observed on the S-meter when the receiver is first turned on.

A signal-strength meter is incorporated as part of the agc system. The meter is connected so as to measure the current drawn by the control FET. The *METER ADJUST* control (R_3) is set so the meter indicates full-scale current when the antenna input terminals are grounded. In operation, the R-F GAIN control (R_2) is set so that a small deflection of the meter (toward zero current) takes place with antenna connected but without signal input. At this point, the agc system will control receiver front-end gain in the proper manner, between near cutoff and maximum usable gain.

Power and Switching Circuits—The receiver is operated from a +12-volt 200-ma supply. In addition, -12 volts is required for agc action. The drain of the -12 volt section is only 20 milliamperes and series connected "penlite" cells may be incorporated in the receiver, if desired, for this function.

The converter portion of the receiver is switched in and out by means of a small crystal-can relay (K_1 , figure 21) operated by the bandswitch. The relay is normally unenergized in all band positions except 80

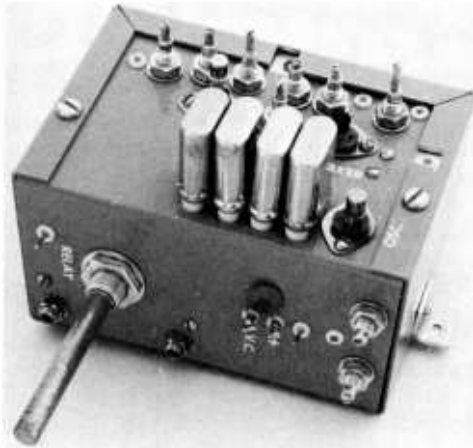

Figure 25

OBLIQUE VIEW OF CONVERTER UNIT

The converter section of the solid-state communications receiver covers the amateur bands between 80 and 10 meters and has an i-f output of 80 meters. The unit is built in a small aluminum box (4" × 2" × 2 3/4") with the major components mounted on the inner, U-shaped box section.

Across the rear of the assembly are the slug tuned r-f coils (l. to r.): 20-, 15-, and 10-meter coils. The 15- and 10-meter mixer coils are immediately to the right. In the right-hand corner of the box is the mixer output coil (L₁).

Along the center line of the converter unit are (l. to r.): The MFE-3006 r-f amplifier socket, the 20-meter mixer coil, and the MPF-105 mixer socket. At the front of the unit are the conversion crystals (l. to r.): 3.5 MHz, 10.5 MHz, 17.5 MHz, and 24.5 MHz. To the right of the crystals is the 2N4124 oscillator socket. Along the front section of the assembly are (l. to r.): the relay feedthrough terminal and piston capacitor C₁, bandswitch S₁, piston capacitor C₂, agc and voltage feedthrough terminals, and (at the extreme right) oscillator collector coils L₂ and L₃.

meters. On this band, the relay removes the converter from the circuit and bypasses the antenna connections around the converter portion of the receiver.

Receiver Construction A multiband receiver such as this is a complex device and its construction should only be undertaken by a person familiar with solid-state devices in general and MOSFETs in particular, and who has built and aligned equipment approaching this complexity.

The solid-state receiver is built on a chassis within a wrap-around metal cabinet measuring 10" × 7" × 4". The cabinet

assembly specified comes complete with panel, chassis, and rubber mounting feet. Other cabinets of the same general configuration, of course, may be used.

General receiver assembly may be seen in the photographs and drawings. The high-frequency converter covering 40 through 10 meters is the most complex assembly and the most compact (figure 25). This unit is built in an aluminum box measuring 4" × 2" × 2 3/4" and is mounted to the left rear of the main chassis. The converter band-switch (S₁) is panel driven by means of an extension shaft as seen in the top-view photograph. Power and control leads are brought out through miniature feedthrough insulators mounted on the side of the box.

The variable-frequency oscillator is a second subassembly built within an aluminum box measuring 3 1/4" × 2 1/8" × 1 1/8". The tuning capacitor used (C₃) is a high-quality unit having full ball-race bearings front and back and a controlled torque. This unit provides minimum drag on the geared dial. The i-f mechanical filter is mounted to the left of the vfo assembly, with the receiver r-f stages and mixer to the left. Both the vfo and the high-frequency converter sections are built as separate units and may be tested and aligned before installation on the main receiver chassis.

The first step in construction of the solid-state receiver is to lay out the chassis, panel, tuning dial, and other major components in a "mockup" assembly to ensure that the receiver will go together without a physical conflict between the components. Figure 26 shows placement of the converter and oscillator assemblies and the i-f filter. The exact location of the vfo box behind the panel and the height of the main tuning capacitor on the side of the box are determined by the position of the tuning dial on the main panel. It is suggested that a trial panel be cut from heavy cardboard and used to support the main dial and assembly so that vfo placement may be checked before any holes are cut in the aluminum panel or the chassis. The panel is held in place by means of the various hexagonal nuts on the controls and the lower lip of the aluminum chassis is cut out to pass the dial mechanism, as shown in figure 27. Placement of the remaining components is not par-

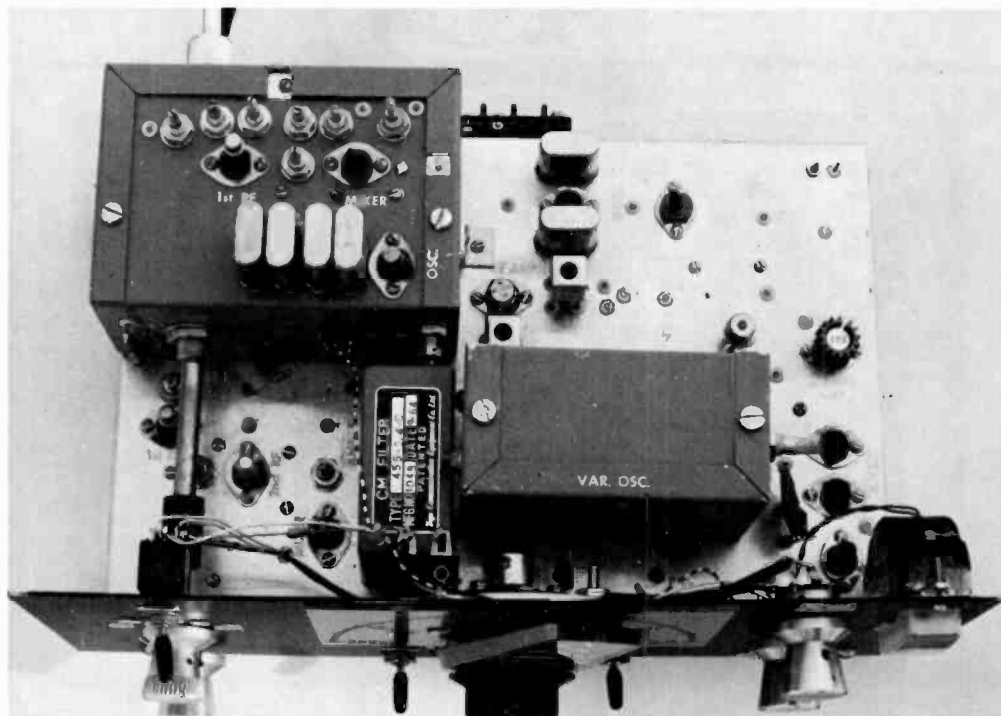

Figure 26

TOP VIEW OF RECEIVER ASSEMBLY

Placement of the major receiver components may be observed in this view. The h-f crystal-controlled converter assembly is at the left with the bandswitch extension shaft running to the front panel. At the center of the main chassis are the mechanical filter and the variable oscillator for the 80-meter portion of the receiver. Directly behind the oscillator are the i-f amplifier and the bfo stage with the associated sideband-selection crystals. At the right is the audio IC stage (with heat sink) and the "meter-adjust" potentiometer. The agc stages are in the right front corner of the receiver, with the 80-meter r-f section located at the front left corner of the chassis.

ticularly critical, and may be done from a study of the photographs. Use of a paper template for drilling the chassis is recommended.

Receiver Wiring The receiver should be wired in an orderly manner, a stage at a time.

To reduce r-f ground currents, all grounds for a single stage should be returned to that stage, preferably to a common ground point at or near the transistor socket. The gate, source, and drain bypass capacitors, for example, can all be returned to a common ground point near the transistor socket, components being grouped about the socket wherever possible, and not "stacked" above the socket, so that the latter can be reached for voltage measurements.

It is suggested that the r-f stages of the main receiver section be wired first, followed by the oscillator assembly, and then the product detector and the audio stage. The agc system, S-meter, and power wiring may be done last. A very small pencil soldering iron, miniature solder, and small diameter (No.22) hookup wire are recommended for ease in assembly. The various tuned circuits are wired and grid-dipped to frequency and the interstage shields are made up and cut to fit (a "nibbling" tool is handy here) as the work progresses. A closeup of the under-chassis r-f stages is shown in figure 27. A two-section variable mica compression-tuning capacitor is used for C_1 (PEAK PRESELECTOR) and has an extension shaft press-fit onto the short tuning stub. The

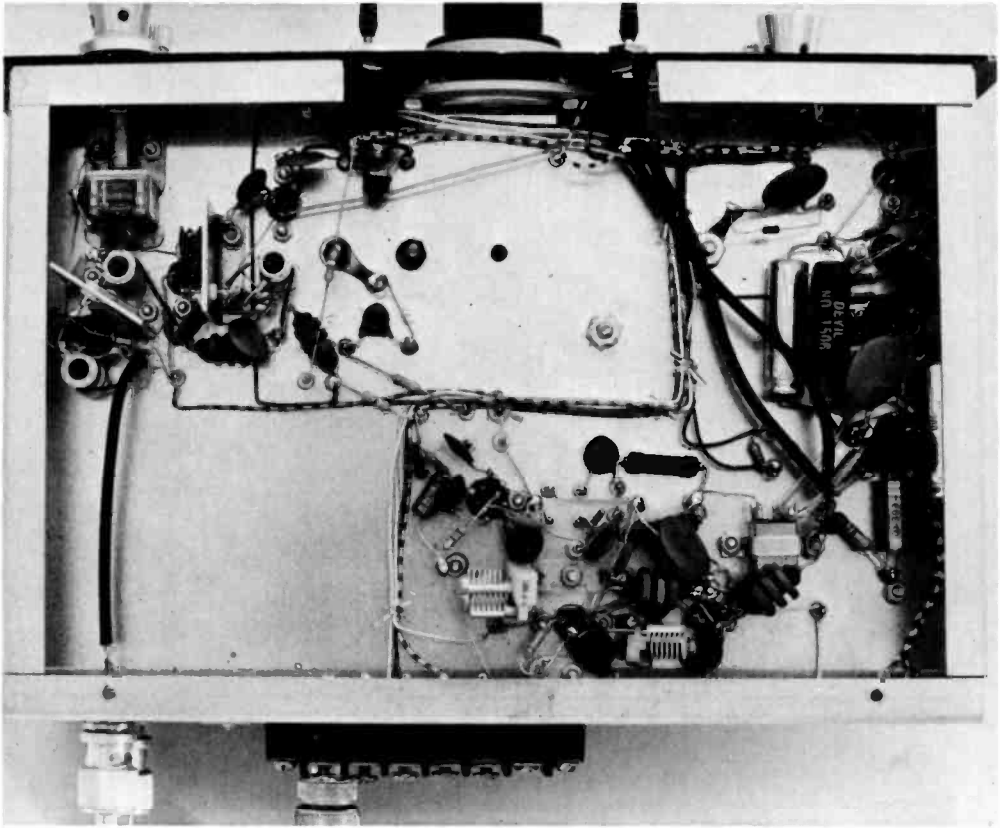

Figure 27

UNDER-CHASSIS VIEW OF SOLID-STATE COMMUNICATIONS RECEIVER

The 80-meter r-f amplifier and mixer stages are seen in the upper left corner of the chassis. The two-section variable mica compression capacitor (C_{14-R}) is mounted to the chassis by means of a small aluminum bracket affixed behind the main panel. The capacitor is driven by a short extension shaft. An intrastage shield is placed across the first r-f amplifier MOSFET socket (Q_1) and a second similar shield is placed across the second r-f amplifier socket. The shields may be made of copper-plated circuit board, aluminum, or thin copper shim stock. The audio circuit and agc components are placed along the right-hand edge of the chassis, with the bfo, detector, and i-f components strung along the rear of the chassis area (bottom of the photograph). The two 35-pf capacitors used to adjust the frequency of the bfo crystals are supported below the chassis by their leads.

Note: The cutout at the front of the chassis is to provide room for the gear-reduction drive mounted to the panel.

capacitor is supported from a small bracket mounted directly behind the panel.

Small shields are mounted across each MOSFET socket. The shields are cut of scrap aluminum or brass and have a mounting foot on them which is held in place by a nearby 4-40 bolt. The first r-f stage MOSFET socket (Q_1) is at the left of the photograph with the small coaxial line from

the converter unit visible at the lower edge of the assembly. To the right is the second r-f stage MOSFET socket (Q_2), with the FET mixer socket above and to the right. The injection line from the vfo passes through a *Teflon* feedthrough insulator mounted in the chassis immediately behind the tuning dial and runs to the gate terminal of the FET socket.

Figure 28
TUNING DIAL
TEMPLATE FOR
THE SOLID-STATE
RECEIVER

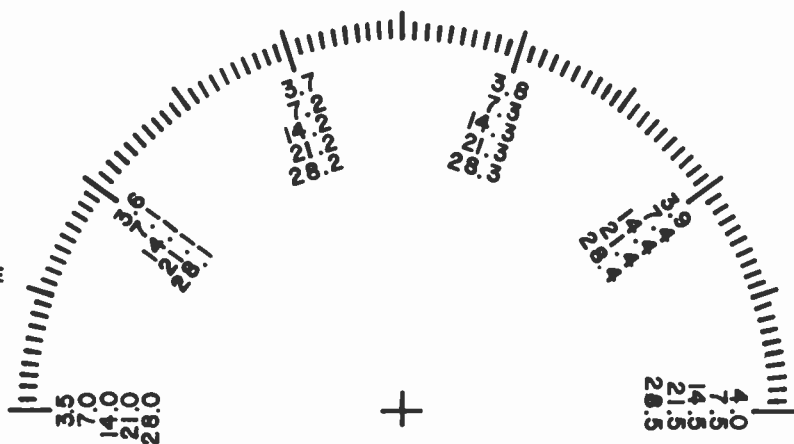

The remainder of the construction and assembly on the main chassis is straightforward. Using $\frac{1}{4}$ -watt resistors and miniature capacitors helps to keep assembly neat and compact. Liberal use of *Teflon* feedthrough insulators and terminals assists greatly in controlling underchassis "clutter."

The main tuning dial is made up of a reduction drive, a home-made pointer, and a calibrated scale etched on a piece of copper-plated circuit board of the glass-epoxy variety. The mask for the negative of the board is reproduced in figure 28. It may be photocopied from the page and used to make a negative for direct reproduction. It should be noted that in the process of etching the board, the photoresist material should not be removed from the board after etching. It is attractive if left on and will prevent the dial surface from being corroded by fingerprints or moisture in the atmosphere.

The Converter Assembly—The general layout of the converter assembly is shown in figures 29 through 31. The MOSFETs and conversion crystals are mounted in sockets placed atop the converter box, with the various slug-tuned coils mounted at the rear of the assembly. Figure 29 shows the rear of the box with the cover removed. The r-f amplifier (Q_1) coils are at the right of the shield partition, with the mixer coils (Q_2) at the left. Directly below the mixer coils is the crystal-can relay (K_1) with the coaxial leads attached to it. The various outer shields of the coaxial lines are grounded at the relay mounting bracket. Note that

several *Teflon* feedthrough insulators are mounted in the L-shaped shield partition to pass power leads between the stages within the box. An oblique view of the r-f compartment is shown in figure 30. The two-section ceramic bandswitch is in the foreground, with the 40-meter piston tuning capacitor (C_1) mounted to the wall of the box in the foreground. Directly in front of the bandswitch is the feedthrough insulator



Figure 29

REAR VIEW OF CONVERTER ASSEMBLY

The r-f amplifier and bandswitch are seen at the right of the internal shield partition. R-f coils are (l. to r.): 20, 15 and 10 meters. Note *Teflon* feedthrough terminals mounted in the intrastage partition. The mixer stage and crystal can relay (K_1) are at the left of the partition. Mixer coils are (l. to r.): 15 and 10 meters. I-f output coil L₁ is at the extreme left.

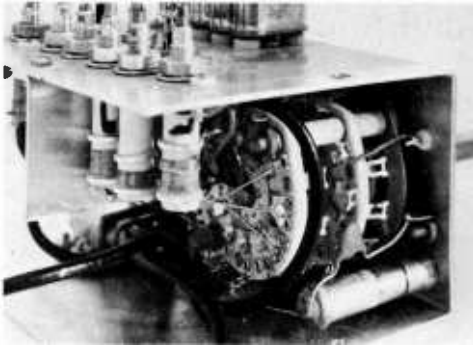

Figure 30

THE R-F AMPLIFIER

The r-f amplifier coils are in the foreground, with the handswitch and piston capacitor (C₁) at the right. The coaxial leads run to the crystal-can relay. The outer shields of the various coaxial lines are grounded to a common point near the relay and also at the free ends in the receiver assembly. Note that coils and handswitch have been arranged for shortest possible lead lengths.

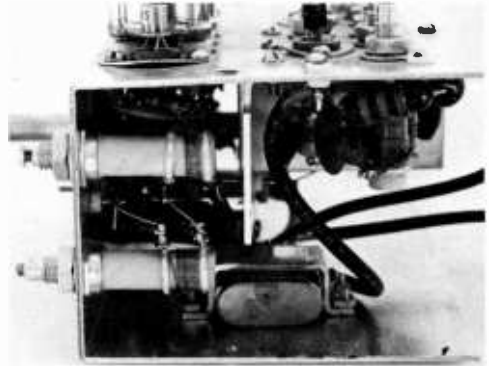

Figure 31

SIDE VIEW OF THE CONVERTER UNIT

The crystal-can relay is in the lower foreground with the 10-meter oscillator coil at the top left and the 15-meter oscillator coil at the bottom left. The internal shield (also seen in figure 27) is L-shaped and isolates the oscillator coils from the mixer coils located at the rear of the chassis deck.

for the lead to the coil of the crystal-can relay. The handswitch is positioned to provide the shortest possible leads to the slug-tuned coils mounted adjacent to it.

An end view of the converter assembly is shown in figure 31. The relay is held in position with a small aluminum U-clamp over the body, and the opposite side of the L-shaped intrastage shield is visible.

The Variable Oscillator—The vfo is the only other separate subassembly. Layout of parts (aside from placement of the main tuning capacitor, mentioned earlier) is not critical. The components are self-supported around the capacitor using short, direct leads to prevent vibration. It is possible to build the unit in a much smaller box, but the good drift characteristic (100-Hz total warmup drift) makes the larger box worthwhile. Both FET sockets are mounted on the vertical front surface of the box, with the oscillator coil (L₄) mounted to one end; and the bandset capacitor (C₂) mounted to the other end of the box.

Receiver Alignment Alignment of the receiver is not difficult if done in a systematic manner and may be done by ear alone. A quicker and better job may be achieved, however, with the use of proper

instruments. The main receiver chassis is aligned first, so that a proper output indicator will be available for subsequent alignment of the converter. All alignment is done with the agc switched off. Before beginning the alignment and before power is applied to the receiver, the tuning meter should be disconnected to prevent its possible damage due to accidental overcurrent. The builder should also note the information in the transistor chapter of this Handbook regarding the handling procedures to be used with the MOSFET transistors, which are inserted toward the end of the alignment operation.

The audio portion of the receiver is tested first. A heat sink is placed over the audio IC (TAA-300) before tests are begun. A 1000-Hz, 10-millivolt sine-wave audio signal is applied at the arm of the *AUDIO-GAIN* potentiometer (R₁) and should result in a signal in the speaker when primary power is applied to the receiver, indicating the audio stage is working. Check the voltage at the drain of the 2N4360 agc control transistor (Q₁₀). It should be close to -12 volts. Removing the audio signal should cause it to drop to almost zero volts. This indicates that the complete agc system is working.

Next, set the *METER-ADJUST* potentiometer (R_3) for zero resistance (short circuit) and reconnect the tuning meter. With the audio signal applied again as before, adjust the meter current for minimum deflection (minimum reading). Removing the audio signal should cause the meter current to increase to a full-scale value. Although the agc is off, the system still controls the meter and it can now be used as an indicator of input signal level to the receiver. Advance the *R-F GAIN* control (R_2) fully clockwise to *Max* position. Apply a 456.5-kHz modulated signal of 1-millivolt level to the input (pin 1) of the IC i-f amplifier (MC-1553G). If the amplifier, the bfo, and the product-detector stages are working, an audio signal should be heard in the speaker. Adjust the detector filter circuit (T_3) for minimum hiss in the speaker when the audio modulation is turned off. Now, adjust the *AUDIO-GAIN* control (R_1) back and forth to make sure it functions properly. Apply the same r-f signal to the input of the mechanical filter and adjust i-f transformer T_1 for maximum signal in the speaker. Varying the input signal frequency above and below 456.5 kHz will provide an indication of the intermediate-frequency passband response of the receiver. Switch the bfo *SELECT-SIDEBAND* switch (S_1) to both positions to ensure that both oscillator circuits are working. Crystal alignment on the filter passband is accomplished by adjustment of the series capacitors.

The next step is to test the variable tuning oscillator. The transistors are inserted in their sockets and the oscillator tuned circuit should be adjusted to tune over the range of 3043.5 kHz to 3543.5 kHz between the extreme positions of the dial. The bandset capacitor (C_2) may be used for this adjustment, along with the slug adjustment of coil L_4 . After the slug position has been determined, it should be fastened in place with a drop of cement to prevent vibration.

The tuned circuits in the r-f stages and the mixer should be adjusted to track across the 80-meter band when the *PEAK-PRESELECTOR* control is adjusted. Preliminary alignment should be done with a grid-dip oscillator with transistors Q_1 , Q_2 , and Q_3 removed from their sockets. When

MOSFETs Q_1 and Q_2 are inserted in their respective sockets, a ferrite bead is slipped over the gate and drain leads of each device to suppress any tendency toward vhf parasitic oscillations. Place the peaking control (C_1) at half capacitance and apply a 10 microvolt, 3750-kHz signal at the input terminal (J_1) of the main receiver. Tune the receiver to the signal and adjust the three tuning slugs in coils L_1 , L_2 , and L_3 for maximum signal output. The receiver may now be used for 80-meter reception.

Converter Alignment—The high-frequency converter should now be attached to the main chassis and the various leads connected. Before the MOSFETs are placed in the sockets, the converter tuned circuits should have been grid-dipped to the approximate working frequencies. Now, the converter bandswitch is set to the 20-meter position and the main tuning dial of the receiver set to 14.250 MHz. A 10-microvolt signal at this frequency is applied to the converter input circuit, making sure that the relay K_1 is properly activated. Adjust the slug of the mixer coil (L_4) for maximum output signal, followed by adjustment of r-f coil L_1 . These adjustments will not be critical due to the large bandwidth of these circuits. The converter must be first aligned on 20 meters since the tuned circuits are basically tuned to that band. Once they are aligned, do not touch them further.

The bandswitch is now placed in the 40-meter position and a 7.2-MHz signal applied to the receiver. Capacitors C_1 and C_2 are adjusted for maximum signal level. In the same fashion, a midband signal is applied to the converter for the 15- and 10-meter bands, aligning them by the slugs in the shunt coils, as before, mixer circuit first. Finally, adjust the 10-meter oscillator circuit (L_4) for best received signal on that band, then adjust the 15-meter oscillator circuit (L_6) for *minimum* received signal when a 20-meter signal is injected into the receiver. This completes alignment of the receiver.

26-6 A Single-Band SSB Transceiver

Probably the most popular item of equipment for SSB operation is the transceiver—



Figure 32

FRONT VIEW OF TRANSCEIVER

The transceiver panel measures $12\frac{1}{8}$ " wide by $6\frac{3}{8}$ " high. The two large controls at center are for final amplifier tank and vfo tuning. On the left area of the panel are the modulator balance control (top), r-f gain adjustment, receiver volume, and microphone gain control (next to the microphone jack). The lower switch is the main power control (S₁) and the meter switch is at the top, right. Below the plate tuning control are the grid tuning adjustment and the function switch, S₂. On the right of the panel are the carrier level control, R₁, and the antenna loading capacitor, C₁. The cabinet is a wrap-around style made from two pieces of perforated aluminum sheet bent into a U-shape and riveted together at the sides. Panel and cabinet are primed and painted with aerosol (spray) paint.

a complete station in one compact package. Since many of the tubes and components are common to both the transmitting and receiving functions, the transceiver can be built compactly and rather inexpensively, and it is well suited for both fixed-station and mobile operation.

The most economical and least complex transceiver to build is one designed for use on a single amateur band. Multiple mixing schemes and complex coil catacombs are thus eliminated, and the "birdie" problem is greatly simplified. Shown in this section is a 200-watt PEP, single-band transceiver (figure 32) which may be used on any one

amateur band from 160 to 20 meters. It is relatively simple in design and is an ideal "first" project for those amateurs interested in building their own sideband gear. While a commercial 9-MHz crystal filter is used, substitution of a homemade crystal filter is practical, further reducing the cost of the transceiver.

The Transceiver Circuit

The transceiver circuit is a proven one that has been employed in many commercial units and is a version of the original W6QK1 (Swan) circuit. Fifteen tubes are used, including a voltage regulator and the

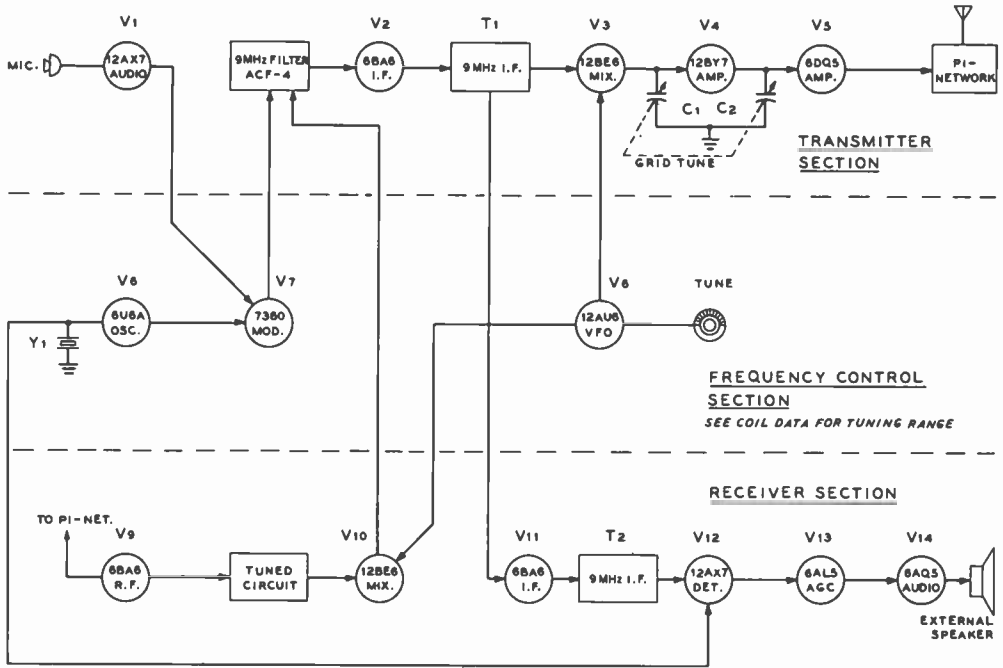

Figure 33

BLOCK DIAGRAM OF SINGLE-BAND SSB TRANSCEIVER

Fifteen tubes are used in a multipurpose circuit. Common r-f tank circuits and i-f filter system simplify construction and reduce cost. A single vfo tunes both receiving and transmitting sections.

unit is designed to be operated from either a 115/230-volt a-c primary supply or a 12-volt transistor power pack (external). Operation of the single-band SSB transceiver and the dual function of some of the tubes and tuned circuits may be seen from an inspection of the block diagram of figure 33.

Reception—In the receiving mode, the circuit takes the form of a single-conversion superheterodyne featuring product detection. The received SSB signal is resonated in the antenna input circuit which, in this case, is the pi-network of the transmitter portion of the unit. The network is capacitively coupled to a 6BA6-remote cutoff r-f amplifier (V₉). The plate circuit (L₁-C₁) of the 6BA6 is common to both receiver and transmitter circuits. A 12BE6 (V₁₀) serves as a receiver mixer, the input signal being mixed with the local vfo signal to produce a 9-MHz intermediate frequency. The vfo stage

is common to both transmit and receive circuits and tunes approximately 200 kHz in the region of 5 to 8 MHz, the exact tuning range depending on the band in use. A 12AU6 (operated at slightly reduced filament voltage serves as the oscillator tube (V₈).

The 9-MHz i-f signal passes through the selective crystal lattice filter (ACF-4) and is amplified in a common i-f stage (V₂) which is transformer coupled to a second (receiving) i-f stage (V₁₁) and then fed to a product detector (V₁₂). At this point in the circuit, carrier is injected in the detector from the 6U8A common crystal oscillator (V₆) and the resulting audio product is amplified in one-half of the 12AX7 dual triode (V₁₂) and the 6AQ5A output tube (V₁₄). A portion of the audio signal returns to the 6AL5 automatic gain control rectifier (V₁₃) to provide an audio-derived agc voltage for the receiver section.

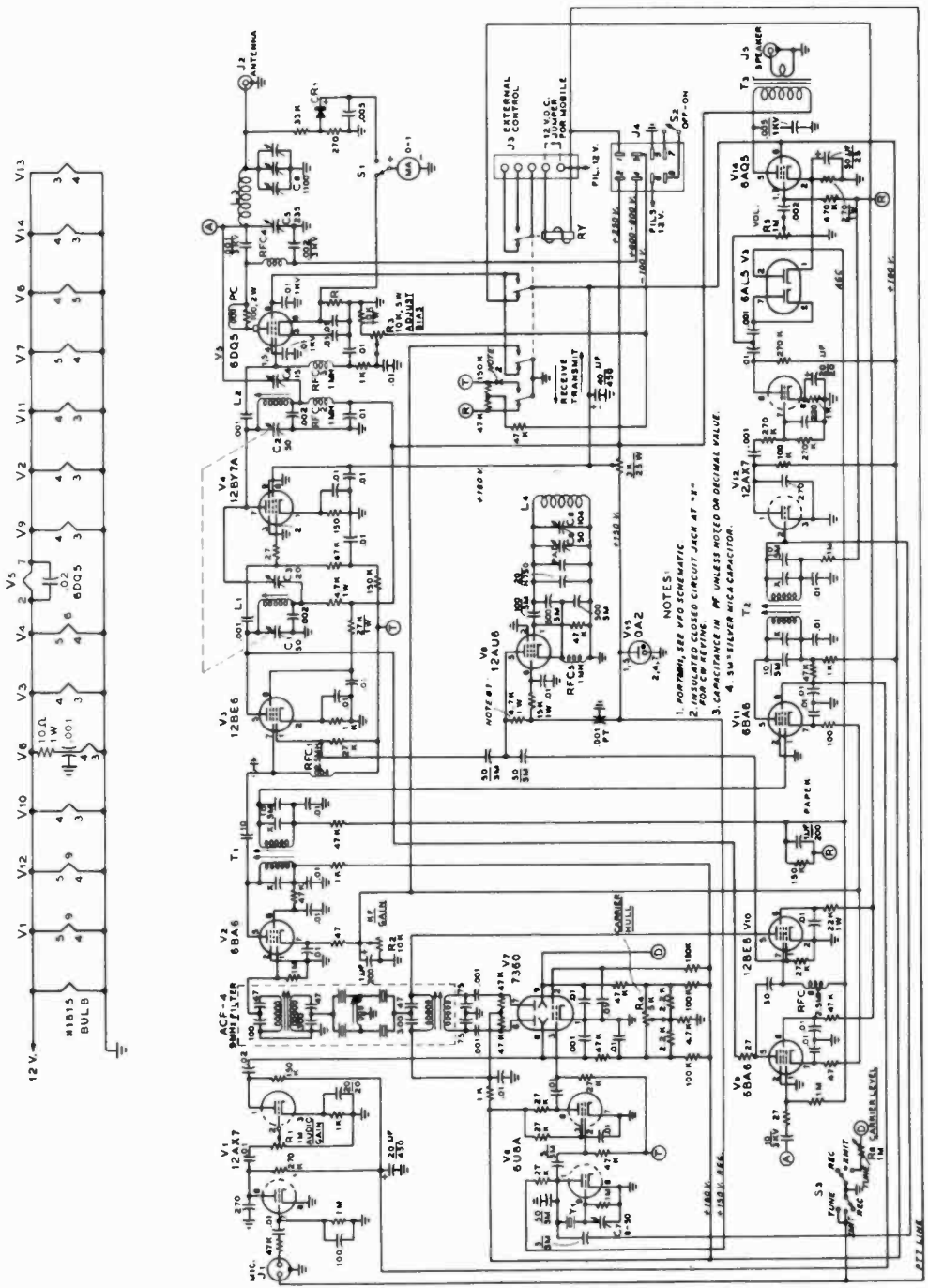

Figure 34
SCHEMATIC, SINGLE-BAND TRANSCEIVER

PARTS LIST FOR FIGURE 34

C_1, C_2 —50-pf each; two Hammarlund HF-50 ganged	RFC ₁ , —1 mH choke; Miller 4652
C_3 —20-pf variable mica trimmer	RFC ₂ —Use Miller RFC-14 for 80-40-20 meters; Use Miller RFC-3.5 for 160 meters
C_4 —15-pf, type APC	RY—4PDT, 12-volt coil; Potter-Brumfield KHP-17-D11
C_5 —235-pf. Gap .024"; Bud 1859	S_1 —Centralab PA-2007
C_6 —365-pf per section; J. W. Miller 2113	T_1, T_2 —10.7-MHz i-f transformer; capacitor X is internal part of unit; Miller 1457
C_7 —50-pf. Centralab 827	T_3 —5000 ohms to 4 ohms; Stancor A-3877
C_8 —50-pf, type APC	Y_1 —International Crystal Co types CY6-9L0 (9001.5 kHz) or CY6-9H1 (8998.5 kHz) as required
C_9 —104-pf precision capacitor; Miller 2101	ACF-4—International Crystal Co 9 MHz SSB filter
CR ₁ —1N34	1—Chassis, 10" x 12" x 3", Bud AC-413
J_1 —Amphenol 80-PC2F	1—Box, 4" x 5" x 3", Bud AU-1028
J_2 —Coaxial receptacle. SO-239	1—Box, 4" x 4" x 2"; Bud AU-1083
J_3 —Chassis receptacle; Cinch-Jones P-308AB	2—Insulated shaft couplers; Johnson 104-264
MA—Calrad, 0-1 ma d-c, 1 $\frac{3}{4}$ " meter	1—Dial drive; Eddystone 892
PC—4 turns #18 around 100-ohm, 2-watt resistor	
R—Meter shunt for 300 ma. Use #30 enamelled, wire wound on 47-ohm, $\frac{1}{2}$ -watt resistor	
RFC ₁ thru RFC ₂ —2.5 mH subminiature choke; Miller 70F-253-A1	

A fixed positive voltage taken from the cathode of the 6AQ5A stage provides delay voltage for the agc circuit to allow maximum receiver sensitivity to be realized with weak signals. Receiver volume is controlled in the grid of the 6AQ5A stage instead of the low-level audio circuit so that agc action is independent of the audio volume level.

Transmission—In the transmitting mode, the circuit takes the form of a single-conversion, crystal-filter SSB exciter, featuring a 7360 balanced modulator and a 6DQ5 linear amplifier. Switching the circuitry from receive to transmit is accomplished by a single relay (RY) which applies blocking bias (−100 volts) to inactivate tubes used only in the receiving mode. The relay also applies screen voltage to the 6DQ5 r-f amplifier (V_3) and grounds the cathode of the common 6BA6 i-f amplifier stage to nullify the receiving r-f gain control during transmission. The receiver r-f amplifier stage remains connected to the plate circuit of the linear amplifier of the transmitter section, but the 6BA6 amplifier is protected from strong-signal damage by virtue of the high negative bias applied to it in the transmission mode.

When transmitting, the sideband carrier is generated by the common crystal oscillator and buffer stage (V_6). The carrier is coupled into #1 grid of the 7360 balanced modulator (V_7) and the audio signal from the 12AX7 speech amplifier is applied to one deflection plate of the 7360. The resulting double-sideband signal passes into the crystal

filter which suppresses the undesired sideband and the carrier, which is already somewhat attenuated by the balanced modulator stage. The desired sideband is amplified in the common 6BA6 i-f stage and passed to the 12BE6 transmitting mixer (V_3) where it is mixed with the vfo signal to produce an SSB signal on the same frequency as the signal being received. The SSB signal is further amplified in the 12BY7A driver stage (V_4) and the 6DQ5 linear amplifier (V_5). When the pi-network plate circuit of the 6DQ5 has been properly tuned for transmission, it is also tuned for optimum reception and requires no further adjustment unless a large frequency excursion is made. The same is true of the 12BY7A tuned circuit (marked *grid tune*).

Transceiver Layout and Assembly The transceiver measures 12 $\frac{1}{8}$ " wide by 6 $\frac{3}{8}$ " high by 10 $\frac{1}{8}$ " deep. A 10" x 12" x 3" aluminum chassis is used for the assembly, with the vfo components mounted in two 4" x 4" x 2" aluminum utility boxes, one atop and one beneath the chassis. The final amplifier plate circuit components are inclosed in a third utility box measuring 4" x 5" x 3" in size. Layout of the major components may be seen in the drawings and photographs (figures 35, 36, and 37). The cabinet is a homemade wrap-around type made of two pieces of perforated aluminum sheet bent into a U-shaped inclosure and riveted together at the sides.

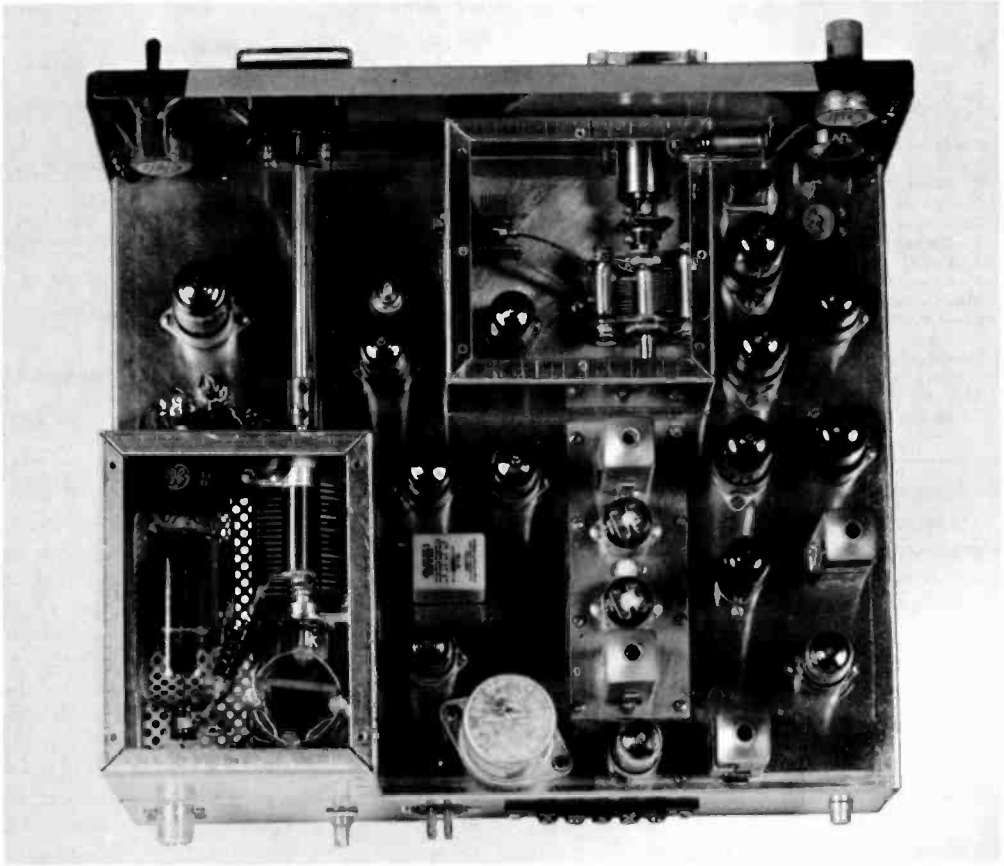

Figure 35

TOP VIEW OF CHASSIS

The SSB transceiver is compact in size, yet not crowded on the 10" x 12" chassis. The use of standard aluminum utility boxes for component enclosures provides excellent shielding at low cost. The box covers have been removed to show interior layout. Ventilation is provided for the horizontally mounted 6DQ5 linear amplifier tube by making a cutout in the chassis below the tube and covering the opening with a sheet of perforated aluminum. A new box cover is made of the same material. The relay to the right of the amplifier box is fully inclosed in a dust cover. Along the rear apron of the chassis are the coaxial antenna receptacle, the bias adjustment potentiometer, the power plug and relay terminal strip, with the speaker jack at the far right.

The 12BY7A driver tube is located between the amplifier box and the front panel, with the 12BE6 transmitter mixer to the right. The 6BA6 receiver r-f stage and 12BE6 mixer are between the relay and the vfo, with the OA2 regulator behind the relay, adjacent to the filter capacitor. The 9-MHz i-f filter strip is at center with the 6BA6 common i-f tube behind it.

At the right, next to the vfo are (going back from the panel): the 9-MHz crystal, the 6U8A oscillator, the 7360, and the 6AQ5A audio amplifier. At the extreme right of the chassis are the 6AL5 agc tube, the 12AX7 speech amplifier stage and the 6BA6 receiver i-f stage.

Data is given in the tables for coils, crystals and frequencies to be used to build a transceiver for 160-, 80-, 40-, or 20-meter operation using standard components. The

layout has been planned to allow short r-f leads where necessary, and to permit proper circuit isolation. In most cases, resistors and bypass capacitors are mounted directly at

the tube-socket pins with liberal use of tie-point terminals to achieve solid construction. The resistor network for balancing the voltage on the deflection plates of the 7360 modulator tube is mounted on a separate terminal board fastened to the side of the chassis, and a second terminal board is used for mounting the r-f choke in the vfo, cathode circuit and the associated capacitors (figure 38). The power plug, relay terminal strip, final amplifier bias potentiometer, and speaker jack are placed on the rear apron of the chassis.

Final amplifier components are placed inside the utility box bolted to the top rear corner of the chassis. The chassis area beneath the 6DQ5 tube is cut out and covered with a perforated aluminum sheet, as are the top and rear of the box, to achieve proper circulation of air around the tube.

The vfo (figure 39) is placed at the front-center of the chassis and is constructed on a $\frac{1}{8}$ -inch thick plate of aluminum measuring $4'' \times 4\frac{1}{4}''$ in size. The vfo tuning capacitor is fastened to this sturdy base by mounting bolts from the underside of the plate. A precision, silver-plated tuning capacitor having ball bearings and closely controlled torque is used in conjunction with a 10-to-1 ratio epicyclic driving head to achieve a smooth, backlash-free tuning system.

One aluminum utility box is bolted to this mounting plate from the bottom side to serve as a shield compartment for the vfo coil and circuit components. The vfo coil is made from airwound inductor stock (*miniductor*) securely affixed to a $\frac{1}{4}$ -inch thick block of *plexiglas* or other insulating material which, in turn, is bolted to the chassis with similar insulating blocks spacing it away from the metal.

Operating voltages are brought into the under-chassis shield box via feedthrough capacitors and the vfo output leads are connected to feedthrough bushings on the sides of the box nearest the transmitting and receiving mixer tubes. A second utility box is bolted to the top of the vfo plate, spaced about $\frac{1}{4}$ inch back from the front apron of the chassis to permit clearance for the dial and drive mechanism. The drive head is passed through a $\frac{3}{4}$ -inch hole in the front

of the utility box and is bolted to the box in line with the capacitor shaft and affixed to it with a flexible coupler. A $4\frac{1}{2}''$ diameter circular piece of sheet plastic is attached to the drive head to form the tuning dial. It is spray-painted white and calibration marks are lettered on it with India ink after final calibration is completed. Sufficient clearance is left between the dial and the chassis so the plastic does not rub on the metal.

The front panel is spaced away from the chassis by virtue of the large nuts holding the various controls on the front apron of the chassis and is affixed in place with a second set of nuts on the control bushings. The $\frac{1}{8}$ -inch space thus created provides room for the dial to rotate freely. A cutout is made in the panel in front of the dial to match the appearance of the meter. The opening is covered with a section of *plexiglas* or *lucite* inscribed with a hairline indicator. A pilot light behind the dial provides proper illumination. The hole in the panel for the tuning shaft should be made sufficiently large so the shaft does not touch the panel, making the tuning mechanism independent of any panel movement.

Transceiver Wiring It is suggested that the receiver portion of the transceiver be wired and tested first. The sideband filter comes as a wired package with matching transformers and requires only a slight modification. The mounting plate is cut down to a width of $1\frac{3}{4}''$ to conserve space and new mounting holes are drilled along the edges of the plate. The filter assembly is then attached to the transceiver chassis over a slot cut just behind the vfo assembly. The output connection of the filter assembly goes to the grid of the 6BA6 i-f amplifier tube (V_2). The grounded side of the input transformer secondary is lifted from ground, bypassed and connected to the 1000-ohm decoupling resistor in the supply-voltage circuit. The other end of this secondary winding is connected to the plate of the 12BE6 receiver mixer tube. The primary winding is modified for balanced input by grounding the junction of the two 75-pf capacitors and connecting the end of the winding to the plates of the

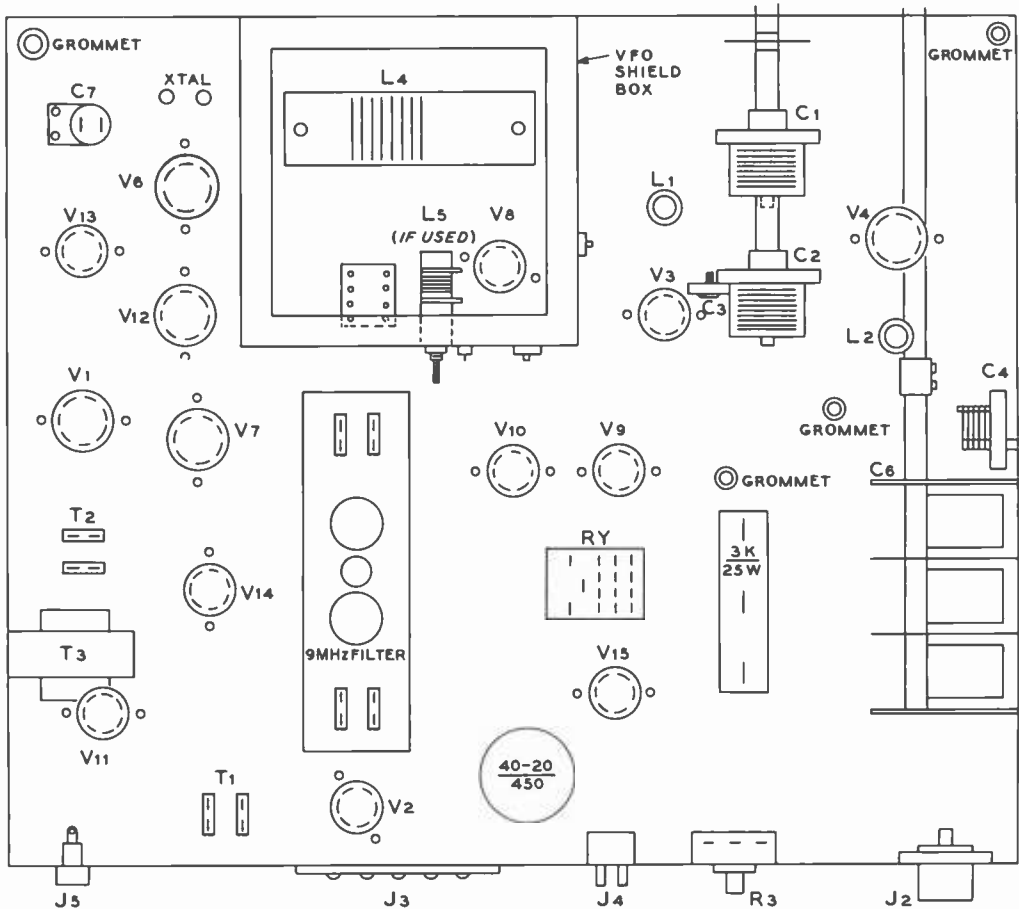

Figure 36

UNDER-CHASSIS LAYOUT OF TRANSCEIVER

7360 balanced-modulator tube through the .001- μ fd coupling capacitors.

The driver (*grid tune*) capacitors (C_1 , C_2) are *Hammarlund HF-50* units ganged together and mounted on the chassis by means of the supplied brackets. A flexible coupling is used to extend the shaft through the front panel. The 12BY7A neutralizing capacitor (C_3) is soldered directly to the stator terminal of the plate-circuit capacitor (C_2) of the amplifier stage. The final amplifier neutralizing capacitor (C_1) is placed on the side apron of the chassis in front of the three-gang antenna loading capacitor (C_6).

Transceiver Coils and Circuits—Coil and tuned-circuit data for the various amateur bands are given in figure 40. For the 160-, 80-, and 20-meter bands, the fundamental frequency of the vfo is employed. For 40-meter operation, the plate circuit of the vfo doubles the oscillator frequency to the 16-MHz range. Lower sideband is used for the 160-, 80-, and 40-meter bands, and upper sideband for the 20-meter band. Substitution of crystal Y_1 will reverse the sidebands, as shown in the table. Additional loading capacitance may be required for proper amplifier operation on 160 meters and may take the form of a 1000-pf (1250-

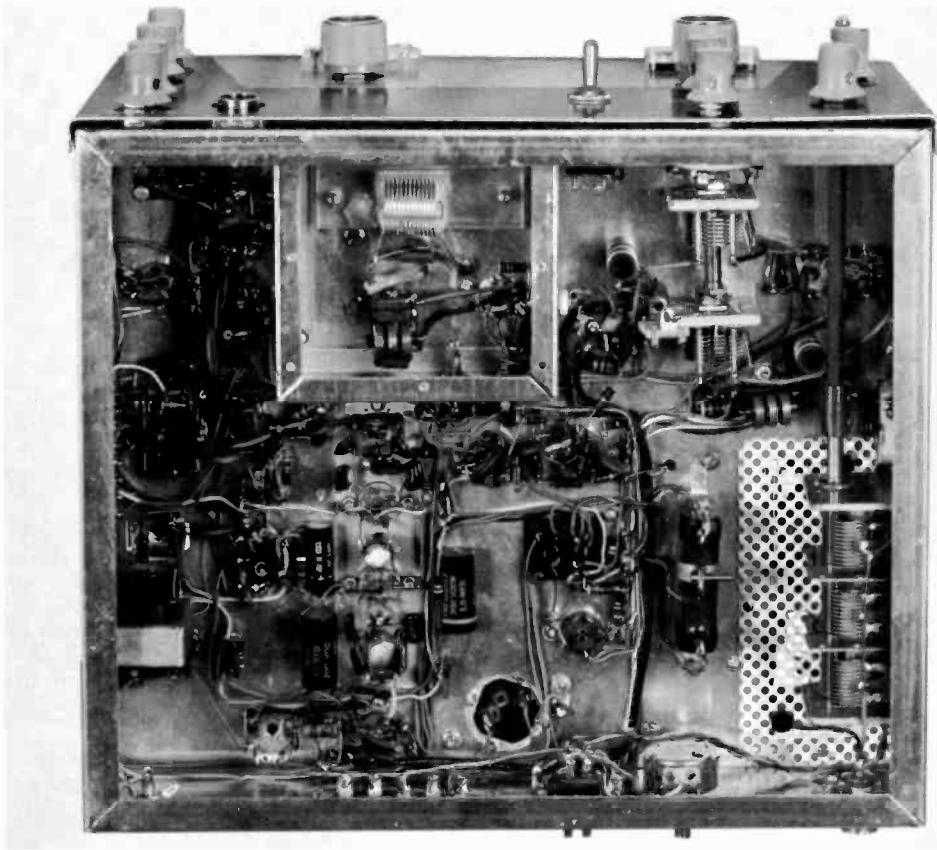

Figure 37

UNDER-CHASSIS VIEW OF THE TRANSCEIVER

The bottom plate has been removed from the vfo compartment to show internal layout. The three-gang antenna loading capacitor, C_a , is bolted to the side apron of the chassis (right) as is the audio output transformer (left). Small components are soldered directly to tube socket terminals and adjacent tie-point strips, leaving the sockets clear for voltage measurements. See Figure 36 for placement of major components.

volt) mica capacitor placed in parallel with antenna loading capacitor C_a .

Transceiver Alignment Before starting alignment of the transceiver, it is suggested that a wiring check be made and a voltage check be done with a suitable power supply. No high voltage is required to begin with, and the screen power lead of the 6DQ5 should be temporarily disconnected at the socket pin and taped until preliminary alignment is completed. After

the slider on the 300-ohm high-voltage dropping resistor has been adjusted to provide a tap voltage of about 180, tube-socket voltages should be compared to the voltage chart (figure 41). The difference noted in receive and transmit voltage in some cases is due to the cutoff bias being switched in and out of the circuit by the changeover relay. The relay is d-c operated, and for fixed-station service a 12-volt d-c source must be used. When operating mobile this relay terminal is jumpered to the 12-volt d-c filament supply.

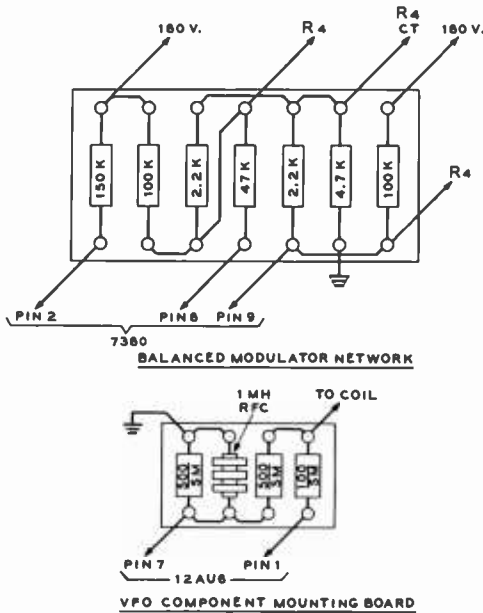

Figure 38

TERMINAL BOARD LAYOUT

The receiver i-f system is aligned first by injecting a 9-MHz modulated test signal at the grid of the receiver i-f amplifier (V_{11}) and tuning the slugs in transformer T_2 for maximum audio signal in the attached speaker. The test generator is then moved back to the input grid of the common i-f am-

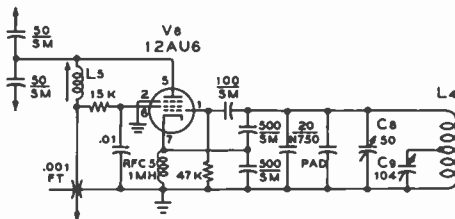

Figure 39

40-METER VFO SCHEMATIC

The 40-meter model of the single-band SSB transceiver employs the second harmonic of the oscillator frequency. A doubler coil, L_4 , is placed in the plate circuit of the vfo in place of the 4.7K load resistor. Tuning capacitor C_6 is tapped down the grid coil to cover the tuning range desired. Tap point and padding capacitor data are given in Figure 40.

Figure 40

COIL DATA	
<u>L_{1, L₂}</u>	
3/8" DIA. SLUG TUNED COILS	
160 METERS-	220UH MILLER #21A224RB1
80 METERS-	22UH MILLER #21A225RB1
40 METERS-	15UH MILLER #21A155RB1
20 METERS-	3.3UH MILLER #21A330RB1
<u>L₃</u>	
160 METERS-	35 TURNS #20 ENAMEL WIRE CLOSE WOUND. 1 1/4" DIA., 1 3/4" LONG.
80 METERS-	24 TURNS #18 TINNED WIRE. AIR-DUX #1014A. 1 1/4" DIA., 1 3/4" LONG.
40 METERS-	14 TURNS #18 TINNED WIRE. AIR-DUX #1014A. 1 1/4" DIA., 1" LONG.
20 METERS-	11 TURNS #18 TINNED WIRE. AIR-DUX #8087. 1" DIA., 1 1/2" LONG.
<u>L₄</u> NOTE: C ₆ TAPPED ON L ₄ FOR VARIOUS RANGES.	
<u>BAND TUNING RANGE</u>	
160 7200-7000 kHz	9 TURNS #20 TINNED WIRE, 3/4" DIA., 3/4" LONG. TAP 4TH TURN FROM GROUND END. AIR-DUX #616. PAD CAPACITOR 51-PF 5M.
80 5500-5000 kHz	12 TURNS #20 TINNED WIRE, 3/4" DIA., 3/4" LONG. AIR-DUX #616. PADDING CAPACITOR 100 -PF 5M.
75 5200-5000 kHz PHONE	SAME COIL AS ABOVE. TAP 8TH TURN FROM GROUND END. PADDING CAPACITOR 180 -PF 5M.
40 8000-8150 kHz	9 TURNS #20 TINNED WIRE. 3/4" DIA., 3/4" LONG. TAP 3RD TURN FROM GROUND END. AIR-DUX #616. NO PADDING CAPACITOR.
40 8100-8150 kHz PHONE	SAME DATA AS ABOVE, EXCEPT TAP 2ND TURN FROM GND END
20 5000-3500 kHz	SAME DATA AS FOR 80 METERS.
20 5200-5350 kHz PHONE	SAME DATA AS FOR 75 PHONE. ADJUST TRIMMER C ₆ FOR DESIRED RANGE.
<u>L₅</u>	
40 18000-18300 kHz ONLY	3/8" DIA. SLUG-TUNED COIL. 3.3UH. MILLER 21A330RB1
CRYSTAL DATA (Y ₁)	
160 METERS LOWER SIDEBAND	- USE 9001.5 kHz
80 METERS LOWER SIDEBAND	- USE 9001.5 kHz
40 METERS LOWER SIDEBAND	- USE 9001.5 kHz
20 METERS UPPER SIDEBAND	- USE 8998.5 kHz

plifier (V_2) and transformer T_1 is adjusted for maximum signal. A vacuum-tube voltmeter on the agc line is helpful in alignment.

When the test signal is injected at the plate terminal of the receiving mixer tube (V_{11}) tuning becomes rather sharp going through the sideband filter. The filter is factory tuned and needs little adjustment other than peaking the top slugs of the two filter transformers. The secondary of the input transformer should be checked, but should not require adjustment more than one-half turn in either direction.

Figure 41

TUBE-SOCKET VOLTAGE CHART										
TUBE		1	2	3	4	5	6	7	8	9
V ₁	12AX7	R- T-	50 55	0 0	.8 1	0 0	12 12	40 45	0 0	CT CT
V ₂	6BA6	R- T-	0 0	0 0	0 0	8 8	175 175	75 70	.8 .5	
V ₃	12BE6	R- T-	-40 -1	0 8	0 0	12 12	220 210	220 80	-40 0	
V ₄	12BY7	R- T-	0 4	-35 -5	0 0	0 0	12 12	CT CT	250 250	180 180
V ₅	6DQ5	R- T-	-60 -60	8 8	0 0	0 180	-50 -60	0 0	8 8	180 180
V ₆	6U8	R- T-	75 75	-40 0	180 100	8 0	0 35	180 0	0 0	-2 -2
V ₇	7360	R- T-	0 0	180 75	-40 -1	8 8	0 0	180 140	180 140	24 24
V ₈	12AU6	R- T-	8 8	0 0	0 0	10 10	120 120	115 115	0 0	
V ₉	6BA6	R- T-	0 -70	0 0	0 0	8 8	210 200	80 0	.2 0	
V ₁₀	12BE6	R- T-	-5 -8	0 0	0 0	12 12	180 175	80 0	-2 -107	
V ₁₁	6BA6	R- T-	0 -107	0 0	0 0	8 8	175 175	80 140	.5 0	
V ₁₂	12AX7	R- T-	145 175	0 -75	0 0	0 0	12 12	100 100	0 0	.4 CT
V ₁₃	6AL5	R- T	10 0	0 -140	8 0	0 0	0 0	0 0	0 0	
V ₁₄	6AQ5	R- T-	0 -60	10 0	0 0	8 0	225 250	180 180	0 -60	
V ₁₅	0A2	R- T-	150 150	0 0	0 0	0 0	150 150	0 0	0 0	

NOTE: MEASUREMENTS MADE WITH A 20,000 OHM-PER-VOLT METER. NO SIGNAL INPUT, R-F GAIN ADVANCED TO MAXIMUM, AUDIO GAIN OFF. FILAMENTS A.C.

POWER SUPPLY REQUIREMENTS	
LOW VOLTAGE -	250 VOLTS AT 110 MA.
BIAS -	110 VOLTS NEGATIVE AT 10 MA.
HIGH VOLTAGE -	800 TO 800 VOLTS AT 300 MA.
FILAMENTS -	12.6 VOLTS A.C. OR D.C. AT 3.7 A.

Before an "outside" signal is received, the variable-frequency oscillator must be aligned to cover the desired operating range, as listed in the coil table. The alignment procedure is the same for any band; only the frequency range is different as indicated on the chart. Use of a good frequency meter (such as a BC-221) will be helpful at this point. With the 80-meter unit as an example, the vfo must tune from 5.5 to 5.0-MHz for proper coverage of 3.5 to 4.0 MHz. The carrier crystal is at 9001.5 kHz to properly place the carrier on the slope of the filter for lower sideband output. Coil L₁ of the 6BE6 transmit mixer is tuned to 3.5 MHz with the aid of a grid-dip oscillator, the slug being adjusted with capacitor C₁ set near maximum capacitance. The entire 80-meter band can then be covered by peaking the pi-network and grid-circuit tuning controls.

Alignment of the transmitting circuits is best done with the v.t.v.m. using an r-f probe for signal indication. The function switch is placed in the *tune* position and the carrier-level control (R₀) advanced toward maximum. R-f voltage at the plate of the 6U8A oscillator should measure about 3 or 4 volts, and about the same value should be observed at the plate of the buffer section of this tube. Inasmuch as the filter transformers and transformer T₁ have been adjusted previously, no further adjustment of these circuits is required. The r-f probe can now be placed at the grid of the 6DQ5 amplifier tube socket and the slug in coil L₂ adjusted for maximum r-f voltage reading. This peaks grid tuning so that coil L₂ will track with the previous alignment of coil L₁.

Final Adjustment and Neutralization The 12BY7A stage should now be neutralized. To accomplish this, all power is turned off and the screen lead temporarily removed from the 12BY7A socket. With power again turned on, circuits resonated, and the function switch in the *tune* position, neutralization capacitor C₃ is adjusted with a nonmetallic screwdriver for minimum feedthrough of r-f voltage as measured with the v.t.v.m. probe placed at the #1 grid terminal of the 6DQ5 socket. The screen lead to the 12BY7A socket is replaced when this operation is concluded. The same technique is employed with the 6DQ5 stage as was used with the driver stage. With screen (and plate) voltage removed from the 6DQ5, but with drive applied, the v.t.v.m. is placed on the antenna terminal of the transceiver and neutralizing capacitor C₁ adjusted for minimum voltmeter indication. The pi-network circuit, of course, is in resonance for this operation, as determined by a grid-dip oscillator.

Up to this point, all tuning has been done with carrier injection. For proper sideband operation, the carrier must be removed and the unit excited by an SSB signal. The technique is to position the carrier crystal frequency properly on the filter "slope" and then to balance out the carrier in the 7360 modulator stage. Capacitor C₇ varies the frequency of the crystal oscillator a suffi-

cient amount to find the proper point for the carrier on the passband slope of the filter. The adjustment of this point can best be made by ear, when receiving a sideband signal. Adjust capacitor C_7 until the received audio of an SSB signal sounds natural and pleasing. The crystal should be about 1500 Hz away from the 9-MHz filter center frequency. The frequency displacement, of course, will remain the same while transmitting.

Carrier null is accomplished by adjustment of the balance control (R_1) on the panel. The r-f probe is placed at the grid of the 6DQ5 stage and the function switch turned to *transmit*. No audio signal is desired. The balance potentiometer is adjusted for minimum indicated reading on the v.t.v.m., which should be 1 volt or less. Operation of the audio system and balanced modulator may now be checked by noting the voltage swing while talking into the microphone. A sustained audio tone will swing the meter to 30 or 40 volts peak reading. It is helpful to monitor the signal in a nearby receiver while these adjustments are being made.

Transmit Operation The screen-voltage lead may now be reconnected to the 6DQ5 tube socket and high voltage provided for the plate circuit. Potentials between 400 and 800 volts may be used for the 6DQ5, with proportionately higher output at the higher plate voltages. An antenna or dummy load must be connected to the transceiver to complete the final checkout and bias adjustment. The meter switch is set for *plate current* and the function switch for *transmit*. The bias potentiometer on the rear apron is adjusted for a 6DQ5 resting plate current of 25 milliamperes. Antenna

loading is done with the function switch in the *tune* position. As the carrier control is advanced, the final-amplifier plate current will rise in a linear fashion. The amplifier plate circuit is brought into resonance and the grid circuit adjusted for peak plate current reading. Loading control C_6 is adjusted for further increase, reestablishing resonance with the tuning control until the indicated cathode current reaches a value of 275 to 300 milliamperes. Full load current should not be run for more than 20 seconds at a time to achieve maximum amplifier tube life. When the function switch is advanced to *transmit*, amplifier plate current will drop back to the original idling value of 25 ma. As the audio level is raised, speech will kick the indicated current up to values in the vicinity of 125 to 170 milliamperes depending on the individual voice. Too high values of peak current will result in distortion and splatter.

The meter may be switched to read relative power output which, in some cases, will simplify loading the amplifier, especially during mobile operation, as tuning may be done for maximum output reading under a controlled level of excitation.

The 80-meter version of the SSB transceiver is shown in the photographs. The only difference in a unit designed for a different band is modification of the r-f coils and the vfo circuitry. Alignment and tuneup is the same for all bands. The transceiver may be used for c.w. by employing block-grid keying. Operation on c.w. is with carrier control fully advanced and function switch in the *tune* position while transmitting. The switch is manually returned to *receive* for reception.

A discussion of suitable power supplies is given in a later chapter of this Handbook.

Exciters and Station Accessories

The exciter is the "heart" of the station transmitter. Various forms of amplifiers, power supplies, and accessory units may be combined in conjunction with a basic transmitter exciter to form a complete transmitting system which may satisfy a wide range of needs. Several different types of low-power exciters and drivers for the h-f and vhf range are described in this chapter, along with a 144-MHz SSB transverter and 200-watt PEP linear amplifier. Efficient audio filters for improved SSB and c-w reception are described. For the experimenter who is interested in the construction phase of amateur radio, these units should offer interesting ideas and techniques which might well fit in with the over-all design of the basic station equipment. The component nomenclature outlined in figure 1 of the *Receiver* section is employed in the following chapter.

27-1 A General-Purpose Exciter For 6 Meters

It is convenient to build vhf equipment in small units to achieve maximum flexibility, improved shielding, and ease of modification. This concept is demonstrated in this broadband, packaged exciter designed for c-w, a-m, or SSB use in the 50-MHz amateur band. The unit may be used as a driver for

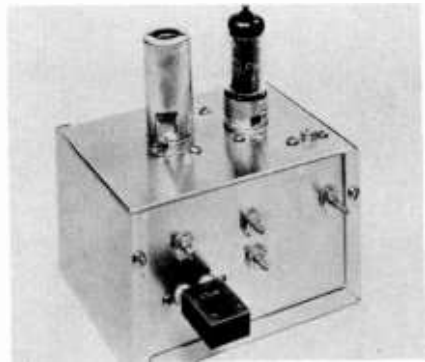

Figure 1

BASIC SIX-METER EXCITER

This broadband 50-MHz exciter delivers 3 watts without retuning over a 1-MHz range and is suitable to drive most high-gain tetrodes of the 100-watt power category. The 6U8A oscillator-multiplier is at the left with the 6CL6 doubler at the right. Directly above the crystal is the oscillator coil (L₁) and to the right are the interstage coils (L₂ and L₃). To the right is doubler coil (L₄). The output jack (J₁) is to the right of the 6CL6.

uhf gear in the higher-frequency region in addition to being suited for general-purpose operation on 6 meters. The exciter delivers about 3 watts which is sufficient to drive most class-C amplifiers in the 100-watt power category and some high-power tetrode tubes up to the half-kilowatt power level.

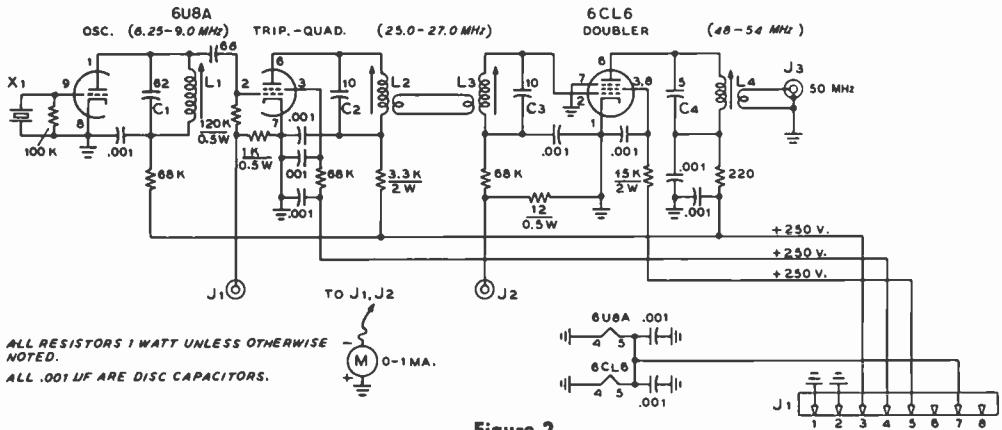

Figure 2

SCHEMATIC OF SIX-METER EXCITER

C₁ thru C₄—Silver-mica capacitors. See figure 4 for coil data. The 12-ohm resistor from test point J₂ to ground shunts meter M to 0- to 5-ma range. Separation between coils L₁ and L₂ is about 1/4 inch. Either link coil may have to be reversed to obtain maximum grid drive to 6CL6.

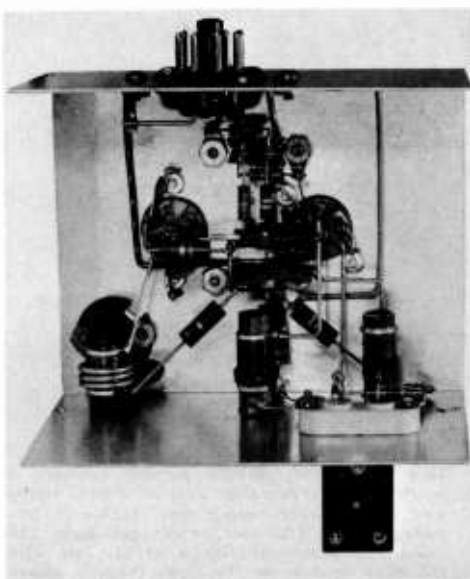

Figure 3

UNDER-CHASSIS VIEW OF SIX-METER EXCITER

Small components are grouped around tube sockets. Common ground connection to lug under bolt of each socket is used. Oscillator coil is at left, L₁ and L₂ at center, and L₃ at right. Link is wound around "cold" end of coils. For use as a transmitter, it is recommended that output link be series tuned to ground with 25-pf capacitor as is done with 2-meter exciter.

An auxiliary high-power amplifier for this exciter is also described.

The Exciter Circuit The schematic of the 50-MHz exciter is shown in figure 2. The triode section of a 6U8A (6EA8) is a tuned-plate oscillator using crystals in the range of 6.25 MHz to 9.0 MHz. Figure 4 lists the choice of crystals for each band and the frequencies to which the resonant circuits in each stage are tuned for output in the 50- and 144-MHz bands. A fundamental-frequency type crystal oscillator is used instead of an overtone circuit for improved frequency stability and better c-w keying. The pentode section of the 6U8A serves as tripler or quadrupler, depending on the crystal frequency and the band in which output is desired. The third stage, a 6CL6 pentode, always operates as a frequency doubler. Inductive coupling is used between the frequency-multiplier stages to attenuate the various unwanted harmonic frequencies generated by the multipliers. The r-f output of the 6CL6 doubler is link-coupled to the coaxial output circuit by means of a small coil wound around the B-plus end of the plate tank coil.

Proper exciter operation is monitored by grid-current metering in the multiplier stages, accomplished by a 1-milliamperere d-c meter. The metering circuit provides a full-scale

reading of 1 ma at test point J_1 and 5 ma at J_2 . The screen voltage for the multiplier stages has been brought out to separate pins on the power receptacle so that these circuits may be used for power control, or may be keyed for c-w operation. The B-plus lead to the 6CL6 may also be broken for metering purposes, if desired.

Exciter Construction The 6-meter exciter is built on a small aluminum chassis box which provides good shielding and easy access to the under-chassis wiring. A 4" x 5" x 3" box is used, with the major components mounted on the half of the box which forms an open-end chassis, as shown in the photographs.

Sockets and components are positioned to permit very short interconnections. All disc ceramic capacitors are placed in position with the shortest possible lead length, and those units which bypass the screen-grid terminals of the 6CL6 and pentode section of the 6U8A should be connected between the screen and cathode (ground) pins of the respective tube socket. Most resistors are soldered between socket pin and tie point terminals. Power leads are run close to the chassis to reduce r-f pickup.

Exciter Adjustment The exciter may be adjusted for broadband operation between 50 MHz and 51 MHz. Two crystals at approximately 8.375 and 8.450 MHz (output frequencies of 50.25 and 50.7 MHz, respectively) are used for initial adjustment.

After the wiring has been checked, power is applied to the 6U8A tube. The negative terminal of a 0- to 1-ma d-c meter is connected to test point J_1 and the positive terminal of the meter is grounded. The slug of oscillator coil L_1 is tuned for maximum meter indication (about 0.3 ma). Adjust the slug so that the oscillator starts immediately each time plate voltage is applied.

Screen voltage is next applied to the multiplier section of the 6U8A and the 6CL6 is placed in its socket. The 8.45 MHz crystal is substituted for the 8.375-MHz unit and the slug in coil L_2 is adjusted for maximum 6CL6 grid current (about 1.3 ma). This step is followed by adjustment of

the slug of coil L_3 for maximum grid current using the 8.375-MHz crystal. Switching crystals back and forth and adjusting the slugs of coils L_2 and L_3 will permit substantially constant 6CL6 grid current to be measured at test point J_2 across the appropriate frequency range.

The next step is to connect a suitable dummy load, such as four #47 pilot lamps (6.3-volt, brown bead) in parallel to output receptacle J_3 and apply all screen and plate voltages to the exciter. The slug of plate coil L_4 is adjusted for maximum bulb brilliance. Using various crystals in the proper range, the exciter coils may now be repeaked to provide nearly constant power output from the exciter across the lower 1-MHz portion of the 6-meter band.

When the 50-MHz exciter is coupled to the grid circuit of a succeeding amplifier through a short length of coaxial line, plate coil L_4 should be readjusted so that maximum drive to the amplifier occurs at about

Figure 4
COIL AND CRYSTAL TABLES
FOR VHF EXCITERS

L_1	4.2 to 8.7 μ h. 30 turns No. 30 e. close-wound, $\frac{3}{8}$ " long, wound on $\frac{3}{8}$ " dia. form, ironcore. CTC type LS-3, 5 MHz.
L_2, L_3	1.4 to 2.0 μ h. 18 turns No. 22 e. close-wound, $\frac{1}{2}$ " long, wound on $\frac{3}{8}$ " dia. form, ironcore. CTC type LS-3.
L_4	0.4 to 0.6 μ h. 11 turns No. 22 e. close-wound, $\frac{1}{2}$ " long same as L_2 .
Link	3 turns No. 16 e., $\frac{1}{2}$ " dia., wound over B+ end of L_4 .

OPERATING FREQUENCY CHART			
Output (MHz)	Xtal and L_1-C_1	Mult. L_2-C_2, L_3-C_3	Doubler L_4-C_4, L_5-C_5
50	6.25-6.75 MHz 8.334-9.0 MHz	25.0-27.0 MHz	50.0-54.0 MHz
144	6.0-6.166 MHz 8.0-8.222 MHz	24.0-24.66 MHz	48.0-49.33 MHz

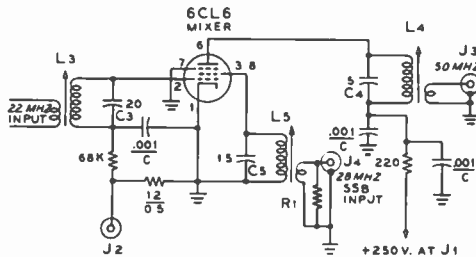

Figure 5

HETERODYNE MIXER FOR 50-MHz SSB

The 6CL6 doubler stage may be converted to a heterodyne mixer for SSB by injecting a low-level, 10-meter SSB signal in the screen circuit. The grid circuit is tuned to the injection frequency of 22 MHz. Grid coil L₃ is the same as in figure 2. Screen coil L₅ is 1.5 μH (J. W. Miller 20A-156-RB1). Load resistor R₁ is 50 ohms and of sufficient power capacity to handle the average power output of the SSB exciter.

50.3 MHz. If the amplifier grid tank is then resonated for maximum drive at about 50.6 MHz, little variation in drive will be noticed over the 1-MHz operating range.

A Heterodyne SSB Exciter for 6 Meters

The general-purpose exciter may be modified to serve as a heterodyne exciter for 6-meter operation as shown in figure 5. The exciter is moved in frequency to 22 MHz and mixed with a 28-MHz SSB signal to provide 50-MHz SSB signal. The SSB signal is injected in the screen circuit of the 6CL6 which now serves as a mixer and the resulting 6-meter signal is retrieved from the plate circuit. The output of the mixer is sufficient to drive a two-stage linear amplifier, such as the one illustrated in figure 6. The 10-meter injection signal need be only about 100 volts or so at the screen of the

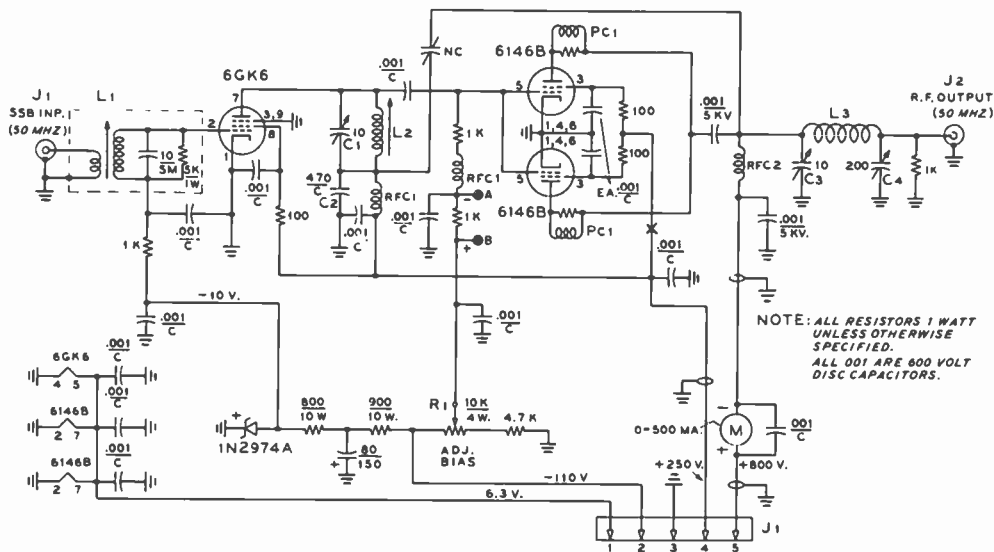

Figure 6

200-WATT PEP LINEAR AMPLIFIER FOR 50 MHz

- C₁—10 pf, Johnson 160-107
- C₂—Variable mica compression unit, Ei-Menco 306. Adjust to about 470 pf
- C₃—10 pf, Hammarlund HF-15X, 1.4 kV
- C₄—200 pf, Hammarlund MC-200M
- L₁—0.7 μH, J. W. Miller 20A-687-RB1. Line is 2 turns #22 enameled wire
- L₂—0.3 μH. Six turns #16, 1/2" diam., 3/4" long
- L₃—0.6 μH. Seven turns #12, 3/4" diam., 1" long
- NC—8 pf, 1.2 kV. Johnson 160-104
- PC₁—50-ohm, 2-watt composition resistor, shunted with 3 turns #16 spaced the length of the resistor

mixer for more than ample output from the 6CL6, and sufficient excitation level may be obtained from the intermediate driver of many SSB exciters and transceivers.

A 200-Watt PEP Linear Amplifier This two-stage linear amplifier package will deliver a maximum power input of 200 to 250 watts PEP. Drive power is less than 500 milliwatts PEP. It is designed to be driven with the 6CL6 heterodyne mixer described previously, but may be used with any 6-meter low-power SSB exciter. Drive requirements are sufficiently modest so that it may be used with a small transistor exciter, if desired.

The schematic of the two-stage linear amplifier is shown in figure 6. A 6GK6 pentode is used as an intermediate stage driving two 6146Bs in a neutralized, pi-section output linear amplifier. If a driving signal of one or two watts PEP is available, the 6GK6 stage may be omitted and the input link directly coupled to interstage coil L_2 .

Bias for the 6146Bs is obtained from an external supply, and a portion of the bias voltage is regulated by a zener diode to obtain -10 volts as bias for the 6GK6. Two positive potentials are required, +250 volts at 50 milliamperes for the 6GK6 and 6146 screens, and +800 volts at a peak current of about 250 ma for the 6146 plates. An external power unit, such as one used for an SSB transceiver will serve as a satisfactory supply for the amplifier.

Amplifier Construction The two-stage linear amplifier is built upon an aluminum chassis measuring 7" × 12" × 3". The input circuit (L_1) is assembled beneath the chassis in a small aluminum box to provide proper isolation from the other tuned circuits. The plate circuit of the 6GK6 is mounted below the chassis, between driver and amplifier stages. The plate circuit components for the 6146Bs, and the tubes themselves, are contained within an aluminum box measuring 5" × 6" × 4" mounted on the chassis deck. The top of the box is removed and a piece of perforated metal substituted to provide proper ventilation for the inclosed tubes. The chassis, in

addition, is punched with ¼-inch diameter holes around the tube sockets to provide additional ventilation.

Wiring is straightforward, with most small components grouped around the respective tube sockets. Before voltages are applied, all tuned circuits are grid-dipped to frequency after the tubes are placed in their sockets.

Amplifier Operation Before the amplifier is placed in operation, the high-voltage lead to the screen circuit of the 6146Bs is broken at point X in the schematic. The various voltages are applied and 50-MHz excitation is applied to the 6GK6. Grid and plate circuits of the driver are tuned to resonance, which can be noted by measuring the d-c grid voltage developed across test points A-B in the amplifier grid circuit. A high-resistance voltmeter may be clipped across the points and the tuned circuits adjusted for maximum reading, which should be of the order of 60 volts or so, when the *adjust bias* potentiometer (R_1) is set for a bias voltage of about -90 volts as measured at the arm of R_1 .

The amplifier is now neutralized by one of the methods discussed in Chapter 11, Section 6 of this Handbook. Excitation is removed, operating voltages are applied and the *adjust bias* potentiometer is set for a resting plate current of 40 ma. The final amplifier stage is tuned and loaded in the normal manner with carrier injection for a resonant peak d-c plate current of 250 ma. The carrier is now removed and voice modulation applied to the exciter. Plate current on voice peaks may reach 100 to 125 ma under full input.

27-2 A 40-Watt Broadband Exciter For 2 Meters

This broadband, 40-watt exciter/transmitter for 144-MHz operation was designed by W6ZO and built by W4HHK. Utilizing coupled interstage transformers, the unit is capable of operation over the 144- to 148-MHz range without the necessity of retuning the intermediate stages. The only tuning adjustment that is required is for the final amplifier stage and antenna circuit.

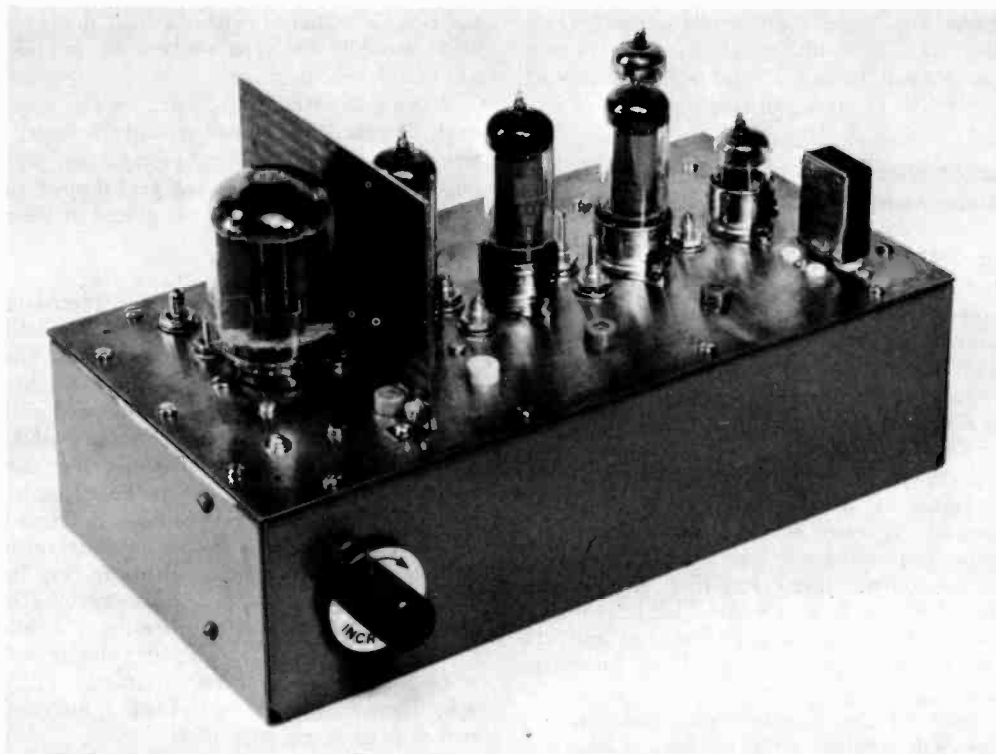

Figure 7

40-WATT, 2-METER BROADBAND EXCITER/TRANSMITTER

Two-meter transmitter employs broadband coupled circuits in driver stages to achieve complete coverage of 144-MHz band without retuning. The unit is designed for continuous service and provides a powerful signal with high attenuation to unwanted spurious emissions. A 7984 "Compactron" tube is used in the final amplifier stage (left). Plate tuning capacitor and output link tuning capacitor are adjacent to 7984. Power output level is adjusted by screen control potentiometer mounted at left-hand end of chassis. Grid current test jacks are seen along the front edge of the chassis. Two crystal sockets are at the front right-hand corner, wired in parallel, to accommodate either FT-243 or HC-6/U style crystals.

To the right of 7984 is the interstage shield and immediately adjacent to it is the 5763 driver, followed by the two 6CL6 multiplier tubes. At the extreme right is the 6AS6 crystal oscillator tube. Heat-sink tube shields are used on the 6AS6 and 6CL6 tubes. To the rear of the oscillator tube is the voltage regulator.

Designed for continuous-duty operation with moonbounce projects, the broadband exciter is well suited for general vhf operation. It may be plate-modulated for a-m service, keyed for c-w or phase-modulated for f-m work. The unit is stable in operation, and subharmonic and harmonic radiation are held to a minimum by the use of multiple interstage tuned circuits.

The Transmitter Circuit

The transmitter circuit is shown in figure 8. A 6AS6 is used as a crystal oscil-

lator utilizing 8-MHz fundamental frequency crystals. Crystal drive level is exceptionally low with this circuit and frequency stability is excellent. The screen voltage of the 6AS6 is regulated, and a small positive voltage is applied to the suppressor element of the tube to enhance the power gain. The oscillator is capacitively coupled to a 6CL6 tripler to the 24-MHz region. Oscillator adjustment may be accomplished by measuring the rectified grid voltage of the 6CL6 at *test point 1*, with the aid of a high-resistance voltmeter.

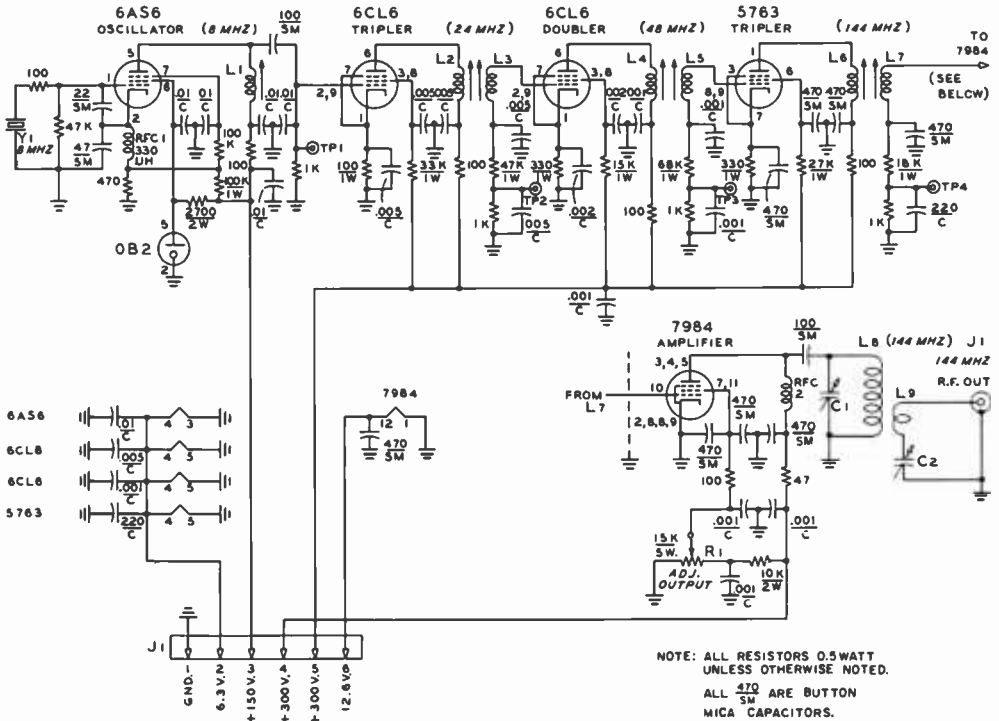

Figure 8

SCHEMATIC, 2-METER TRANSMITTER

C_1, C_2 —9 pf, Johnson 160-104

Note: Coils L_1, L_2 are wound on Cambion (CTC) ceramic form 1538-4-3 (powdered-iron slug for 50-200 MHz), 1/2" diam., coded white. Coils L_3 and L_4 are wound on J. W. Miller ceramic form 4500-4 powdered-iron slug for 50-200 MHz 1/4" diam., coded white

L_1 —46 turns #30 enamel wire, closewound

L_2 —19 turns #24 enamel, closewound

L_3 —15 turns #24 enamel, closewound

L_4 —6 turns #24 enamel, closewound. Space last turn or two wire diameter, if necessary to establish proper broadbanding of circuit

L_5 —7 turns #24 enamel, turns spaced wire diameter. Coils L_1 and L_2 are mounted 11/16" apart

L_6 —3 turns #18 enamel, turns spaced wire diameter

L_7 —2 turns #18 enamel, turns spaced wire diameter. Coils L_6 and L_7 are mounted 11/16" apart, center to center

L_8 —2 turns #12 tinned wire, 1/2" inside diam., turns spaced wire diameter

L_9 —3 turns #18 tinned wire, 1/2" inside diam., turns close spaced. Optimum spacing between adjacent ends of coils is about 3/16". Adjust spacing for maximum output

RFC₁—330 μH. J. W. Miller 70F-334-A1

RFC₂—2-meter plate choke. Ohmite Z-144, or J. W. Miller X-144 (2μH)

A double-tuned transformer is used in the interstage circuit between the 6CL6 24-MHz tripler and the 48-MHz doubler to reduce the residual 8-MHz energy which might otherwise be fed to the doubler stage. The 6CL6 doubler plate circuit is broadly resonant at 48 MHz, yet provides good rejection to 24-MHz, 32-MHz, 40-MHz, and 54-MHz energy, all of which are present

to some degree in the plate circuit of the second 6CL6.

A 5763 is used as a tripler from 48 MHz to 144 MHz and, in turn, is inductively coupled to a 7984 amplifier. A small amount of 48-MHz energy is present in the grid circuit of the 7984 stage, but it is effectively suppressed in the high-Q plate and antenna tuned circuits.

Table 1. Voltage and Power Measurements
(Voltages Measured to Ground. 20,000-ohms/volt Meter used.)
300-Volt Power Supply

Tube	Circuit	Voltage	Current
6AS6 Oscillator	Plate, end of coil L ₁	150	
	Screen, pin 6	105	
	Suppressor, pin 7	0.9	
6CL6 Tripler	Plate, end of coil L ₂	300	
	Screen, pin 3	150	
	Cathode, pin 1	2.2	
	Cathode		22 ma
	Grid, test point #1		350 μA
6CL6 Doubler	Plate, end of coil L ₄	300	
	Screen, pin 3	90	
	Cathode, pin 1	8	
	Cathode		24 ma
	Grid, test point #2		4.3 ma
5763 Tripler	Plate, end of coil L ₄	300	
	Screen, pin 6	245	
	Cathode, pin 7	10	
	Cathode		31 ma
	Grid, test point #3		2.5 ma
7984 Amplifier	Plate, end of RFC	300	
	Screen, pin 7	110	
	Screen		1.4 ma
	Plate		100 ma
	Grid, test point #4		3 ma
	Power Input		30 watts
Power Output		22 watts	
Filament requirements: 6.3 volts at 2.25 amperes and 12.6 volts at 0.6 ampere			

The 7984 has good internal shielding and when used with an external shield separating it from the exciter stages proves to be self-neutralized in the 2-meter region. Double screen-terminal bypassing is used on the 7984 socket to provide the proper low-impedance screen-to-ground path necessary at this frequency.

Power output of the exciter is controlled by varying the screen voltage of the 7984 stage by means of the *adjust output* potentiometer (R₁). With a maximum plate potential of 450 volts on the 7984, an input as high as 80 watts may be run. For the unit shown, the usual power input is about

40 watts at about 315 plate volts. Sufficient drive exists, however, to run the higher input level. For continuous RTTY service, the exciter is usually run at about 35 watts input, providing an output of nearly 25 watts. This is more than sufficient to drive a tetrode amplifier using two 4CX250B's to the 1-kilowatt level. Complete operating data for the exciter is given in Table 1.

The plate circuit of the 7984 is a parallel-tuned configuration having high *Q* to aid in suppressing undesired subharmonics. The antenna circuit, too, is tuned to resonance by means of a series capacitor in the ground return path. Only the amplifier plate cir-

cuit and antenna capacitor need be retuned for frequency excursions within the 2-meter band.

Transmitter Construction The transmitter is constructed upon a piece of copper-plated (two sides) epoxy circuit board measuring $9\frac{1}{2}'' \times 5''$. It is placed atop an inverted aluminum chassis used as a base and dust cover. The chassis measures $9\frac{1}{2}'' \times 5'' \times 2\frac{1}{2}''$. Layouts of the major components are shown in the photographs and in the chassis drawing of figure 10. It must be remembered that a $\frac{1}{2}$ -inch border

must be left around the circumference of the circuit board to permit the board to sit flush on the chassis lips. The board is cut to size and temporarily placed on the inverted chassis and the border allocated and marked with a pencil. The board is then removed for drilling and cutting to mount the sockets, coil forms, and other major components.

The under-chassis vertical shield is made of copper-coated (one side) circuit board and measures $4'' \times 2''$. It is placed across the underside of the 7984 tube socket, carefully notched to fit snugly over the socket and against the board. It is mounted

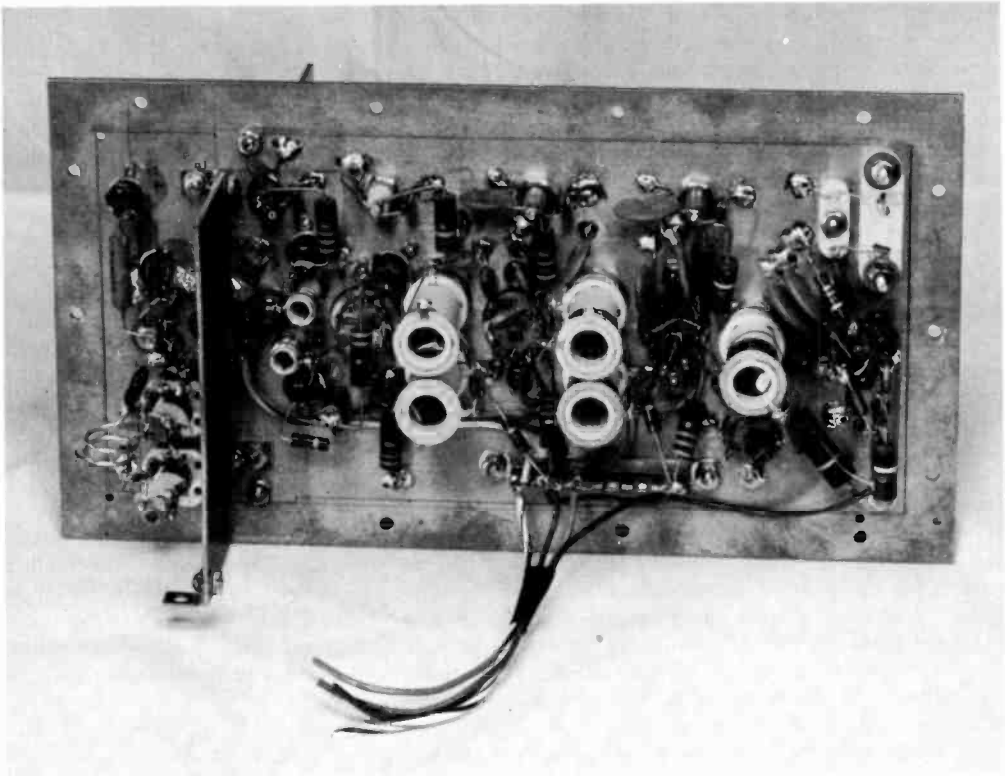

Figure 9

UNDER-CHASSIS PARTS LAYOUT

The 7984 plate tank coil is in the lower left-hand corner of the chassis, to the left of the under-chassis shield, mounted across the center of the 7984 tube socket. One corner of the shield is attached to the chassis base.

At the center of the chassis are the coil forms for the bandpass transformers, with the crystal oscillator stage at the right. A terminal strip at the rear of the chassis is used to terminate the leads to the main power receptacle placed on the back of the aluminum support chassis. Placement of major components is shown in figure 10.

off center so that one edge may be affixed to the aluminum-inclosure by means of a small angle bracket. It is not bolted in place until after the board is wired and attached to the chassis. This shield is located on a line running between pins 8 and 9 and pins 12 and 1 of the 7984 socket.

The 7984 cathode pins (2, 6, and 9) are grounded to the circuit board with very short, wide straps of flashing copper strap. Cathode pin 8 and filament pin 1 are soldered to the shield after all circuit-board wiring is completed and the shield is bolted in place. The copper side of the shield faces pins 8 and 1.

All sockets, coil forms, test-point jacks, etc. are mounted on the circuit board before wiring is started. Space is at a premium in some areas and components must be carefully located and wired in proper order. The filament wiring, grounding of socket pins, and socket bypass capacitors should be connected first. Most capacitors are chosen to be series resonant at the operating frequency of the circuit and should be wired in position with very short leads. Filament and d-c voltages are distributed to each stage from the tie-point strip mounted between coil L_2 and the chassis power plug. A tie-point strip placed near the 6AS6 oscillator tube socket serves to terminate power leads to that tube and the OB2 regulator tube associated with it. The +300 volt line for the final amplifier is run in a shielded wire from the power plug to the 10K resistor and *adjust output* potentiometer control (R_1) and from there to the 47-ohm plate circuit resistor for the 7984. The potentiometer and series screen resistor are mounted on the wall of the aluminum chassis, while the power plug and coaxial receptacle for the antenna are mounted to the rear wall of the chassis. Wiring to the power plug, antenna receptacle, and screen potentiometer is done after the circuit board has been wired and placed atop the chassis.

A $2\frac{3}{4}'' \times 4''$ shield made of plated circuit board is mounted atop the circuit board between the 7984 envelope and coil L_7 . The shield is notched to fit snugly over the edge of the mounting nut of coil L_7 and the edge of *test point 4*. Foil side of the board faces the 7984 and almost touches the glass envelope. There is just enough space

between the 7984 envelope and coil L_7 tuning screw to mount the shield. Relative spacing between coil L_7 and the 7984 tube socket is critical in this respect.

The 470-pf mica button capacitor that bypasses the 7984 screen terminal to ground (see schematic) is mounted adjacent to pin 7 and connection is made to it by means of a short length of $3/16''$ -wide copper shim stock. On the opposite side of the shield, screen pin 11 must be bypassed to cathode pin 9 with a second button capacitor, making leads as short as possible. This will stabilize the 7984 by making the screen circuit self-resonant to ground.

Coil spacing is chosen so as to provide adequate intrastage coupling when the circuits are stagger-tuned for 144 MHz and 148 MHz. The end of antenna coil L_9 adjacent to plate coil L_8 connects to the antenna receptacle (J_1) and the opposite end of coil L_9 connects to the antenna tuning capacitor (C_2). This capacitor is fully meshed when working into a nonreactive 50-ohm dummy load.

Transmitter Adjustment and Tuning When the wiring is completed it should be carefully checked

against the schematic for possible errors. Before power is applied, the various coils may be roughly grid-dipped to the frequencies indicated on the schematic. Coil dimensions given are based on the use of heat-sink tube shields on the oscillator (6AS6) and 6CL6 multiplier tubes. There is a noticeable detuning effect in the plate circuits of these stages when a tube shield is removed. Heat-sink shields are recommended to reduce bulb temperature and extend tube life.

The 6AS6 and OB2 tubes are plugged in their respective sockets and coil L_1 adjusted for proper oscillation with a crystal in the 8-MHz region. When the 6CL6 tripler is in the socket and L_1 is tuned for reliable crystal oscillation, about 0.35 volt should be measured between *test point 1* and ground.

The 6CL6 tripler is tuned to 24 MHz, and about -4 volts should be observed at *test point 2* in the grid circuit of the 6CL6 doubler stage, whose plate circuit is tuned to 48 MHz. Finally, the 5763 tripler is

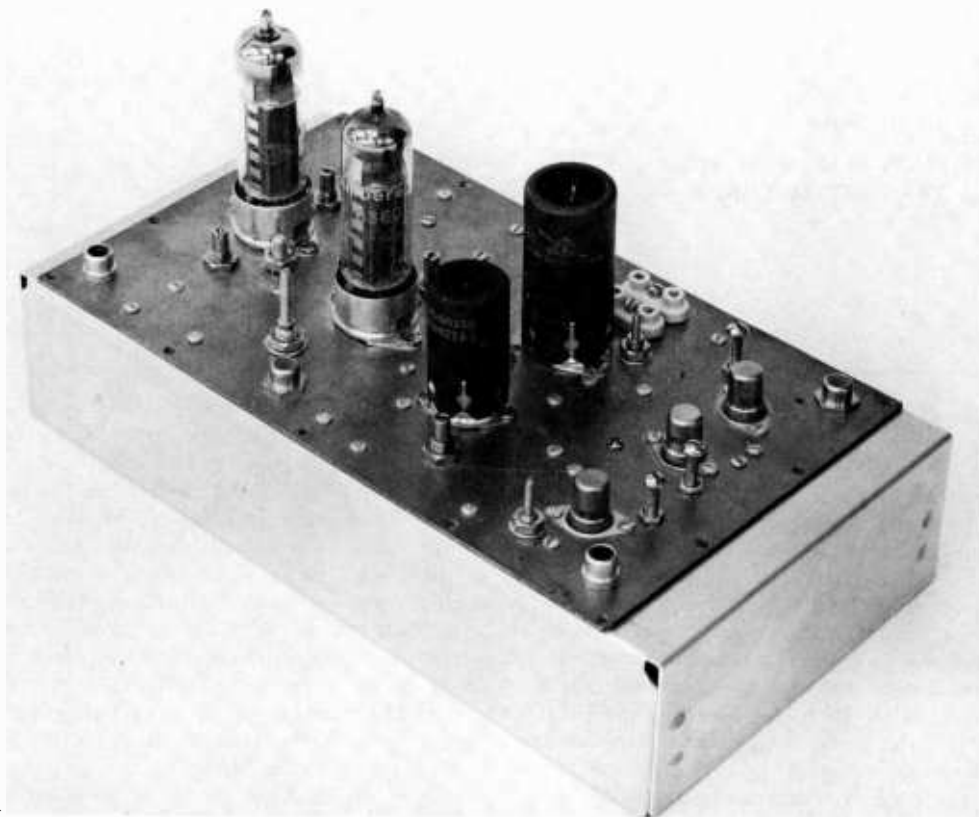

Figure 11

2-METER SSB TRANSVERTER

Designed to be used with an h-f SSB exciter or transceiver, this compact transverter mixes the SSB signal to and from the 144-MHz band. The transverter may be used to drive a 2-kW PEP linear amplifier. Built upon a printed circuit board, the transverter consists of a low-noise converter using nuvistor tubes, and a four-tube SSB-mixer-linear amplifier. SSB excitation may be applied at 20, 15, or 10 meters.

In the foreground of the transverter is the nuvistor converter. Two 6CW4s are used in a cascode amplifier (rear) with a third 6CW4 sherving as a mixer (foreground). Across the middle section of the transverter are the crystal oscillator (6AN8) and multiplier (6AK5). To the left of the oscillator chain is the 6360 mixer, with the 6360 linear amplifier at the left, rear of the chassis deck. Layout of major components is shown in figure 15.

tice calls for the low-frequency SSB equipment to work on either the 20-, 15-, or 10-meter band.

The Transverter Circuit Described in this section is a simple transverter for the 2-meter band (figure 11) that will operate with most low-frequency SSB equipment. The conversion frequency used is 21 MHz, but the unit is adaptable to 14 MHz or 28 MHz, if desired. PEP power

input on the 2-meter band is 12 watts, and the receiver noise figure is better than 4 decibels. The transverter may be used directly, or as a driver for a high-power linear amplifier. Conversion drive power is 2 watts PEP, maximum.

Transmitter Section—The circuit for the transmitter portion of the transverter is shown in figure 12. A 6360 double tetrode is used as an SSB mixer to 144 MHz. In this example, the SSB signal is at 21 MHz

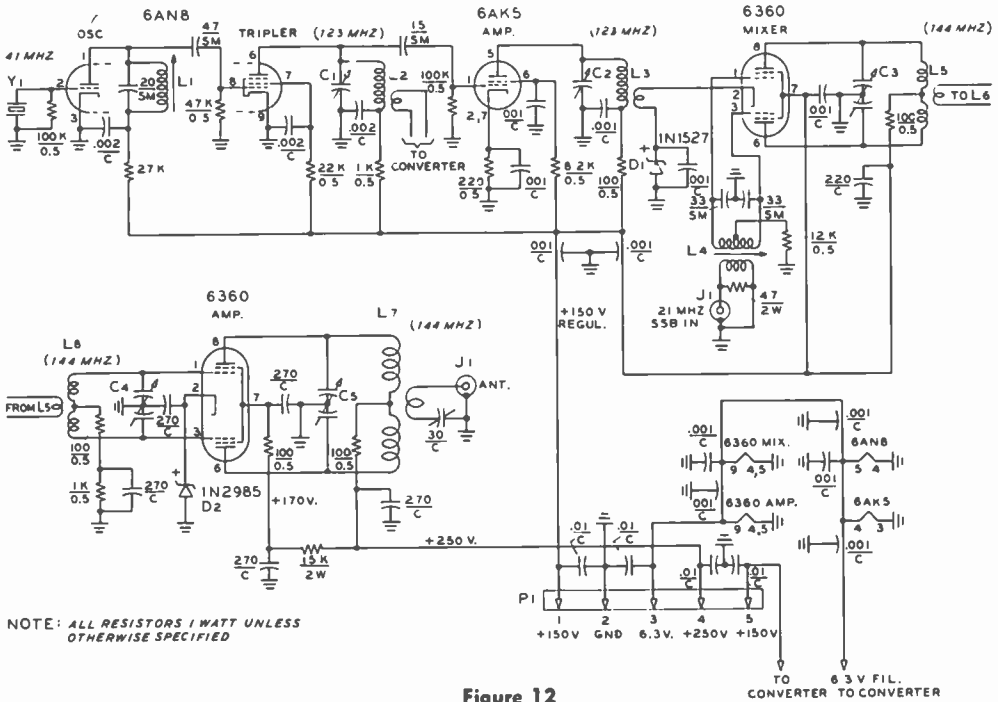

Figure 12

SCHEMATIC, TRANSMITTER SECTION OF TRANSVERTER

- C₁—10-pf piston capacitor
- C₂—8 pf, Johnson MAC-10
- C₃, C₄—11 pf, Johnson 160-211
- C₅—8 pf, Johnson 160-208
- L₁—9 turns #20 e. on 1/4" diam. form. J. W. Miller 4500-3 (green). Resonates in circuit at 41 MHz
- L₂, L₃—5 turns #18, 5/16 diam., airwound. Resonates in circuit at 123 MHz. Link is one-turn hookup wire
- L₄—14 mHz: (6.5μH) 33 turns #26 on 3/8" diam. form, center-tapped. J. W. Miller 4400-3 (green). 21 MHz: (2.8μH) 12 turns #26, as above 28MHz: (1.5μH) 6 turns #26, as above
- L₅, L₆—6 turns #16, 3/8" diam., airwound. One inch long (spaced) with 3/16" gap at center
- L₇, L₈—4 turns #16, 3/8" diam., airwound, 3/4" long. Link coils for L₅ and L₆, one turn each. Link coil for L₇, two turns hookup wire
- D₁—22-volt, 1-watt Zener Diode (Motorola)
- D₂—22-volt, 10-watt Zener Diode (Motorola)

and is injected into a tuned circuit which provides a balanced signal to the control grids of the 6360. The input circuit is swamped with a 47-ohm, 2-watt loading resistor to provide a uniform load for the SSB exciter. The 21-MHz SSB signal is mixed in the 6360 stage with a local oscillator signal of 123 MHz. The crystal oscillator is the triode section of a 6AN8 which uses a 41-MHz overtone crystal. The pentode section of the 6AN8 functions as a tripler to 123 MHz. The 123-MHz mixing signal is further amplified in a 6AK5 stage

and injected into the cathode circuit of the 6360 mixer. A small zener diode (D₁) provides proper bias for the mixer. The resulting 144-MHz SSB signal is retrieved in the push-pull plate circuit of the mixer and is link-coupled to a 6360 linear amplifier. A second zener diode (D₂) provides operating bias for this stage. The 6360 provides a PEP power output of about 6 watts.

Receiver Section—The receiver portion of the transverter is shown in figure 13. Three 6CW4 *nuvistor* triodes are used in a reliable, proven circuit. The first 6CW4 serves as a

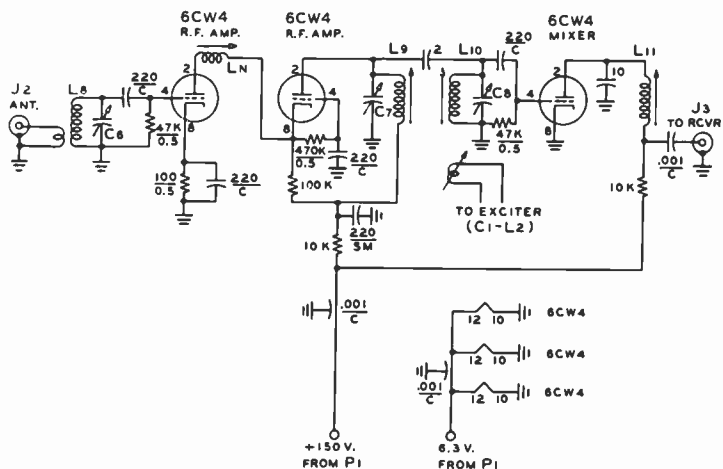

Figure 13

CONVERTER SECTION OF TRANSVERTER

C_1, C_2, C_3, C_4 —10 pf, Centralab 829-10

L_1, L_2 —6 turns #18, 1/4" diameter, airwound, 1/2" long.

Link coil for L_1 is two turns hookup wire. Or, antenna may be tapped directly on L_1 . Tap point chosen for best noise figure

L_3 —5 turns #18, 1/4" diameter, 1/2" long, spaced 1/2" center with L_1 . Link coil 2 turns hookup wire

L_{11} —14 MHz (7 μ H). J. W. Miller 20A-686-RBI

21 MHz (4.5 μ H). J. W. Miller 20A-476-RBI

28 MHz (1.5 μ H). J. W. Miller 20A-156-RBI

L_4 —5 turns #28, 1/4" diam. (0.3 μ H). J. W. Miller 20A-337-RBI

neutralized r-f amplifier which is followed by a second 6CW4 in grounded-grid, cathode-driven configuration in the manner of a cascode amplifier. A third 6CW4 is used as a mixer to the intermediate frequency of 21 MHz. Mixing voltage is link-coupled to the grid of the mixer stage from the 6AN8 tripler stage in the transmitting section of the unit.

Transverter Operation—For reception of 2-meter SSB signals, the +150-volt regulated supply is switched to the converter section (pin 5, plug P_1) by an external changeover relay, and high voltage is removed from the plate and screen circuit of the 6360 linear amplifier (pin 4, plug P_1). The local-oscillator portion of the transverter operates in both transmit and receive modes. The received signal, therefore, is mixed down to 21 MHz and applied to the station receiver or transceiver. For 2-meter transmission, the voltage is removed from the converter section of the unit and high voltage is applied to the linear amplifier. The 21-MHz SSB signal is mixed to 2 meters

and further amplified by the 6360 output stage.

Since most high-frequency SSB equipment provides more than 2 watts PEP output, it is necessary to dissipate the extra transceiver power in a dummy load. A 50-ohm dummy load of adequate power capacity may be used, with a coupling adjustment to the exciter, as shown in figure 16.

Either 20-, 15-, or 10-meter SSB input may be used with transverter. The two higher bands, however, are recommended for use, as control of spurious radiation is easier when the SSB injection frequency is relatively high. If a 20-meter SSB signal is used, for example, weak spurious responses may be found in the 6360 mixer output at 116, 130, and 158 MHz, in addition to the desired SSB signal at 144 MHz. The 130-MHz signal is oscillator feedthrough, the 116-MHz signal is the i-f image, and the 158-MHz signal is a beat between 130-MHz energy and the second harmonic of the 14-MHz SSB signal. When 21-MHz injection is used, these signals move to 102, 123,

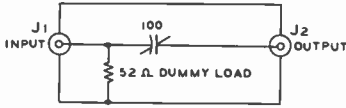

Figure 16

POWER ADAPTER FOR TRANSVERTER

an injection frequency of 14 MHz, the unwanted responses are reduced better than -30 decibels below peak signal level. When the injection frequency is moved to 21 MHz, the rejection of unwanted responses is better than -40 decibels. It is prudent, therefore, to use an injection frequency of 15 or 10 meters to achieve optimum rejection of the spurious frequencies. Finally, it must be remembered that any spurious responses of the high-frequency SSB equipment may possibly ride through the transverter unit, appearing in the output in addition to the above listed responses.

In order to reject most of the spurious signals which may be difficult to separate in the various mixing processes, it is suggested that a high-Q tuned filter be placed after the transverter unit, before the antenna or any following amplifier stage. This sharply tuned circuit will provide a clean, spurious-emission-free signal for 2-meter SSB operation. A suitable strip-line filter is shown in figure 17.

Transverter Construction and Adjustment

The 2-meter transverter is shown in figures 11 and 14.

The unit is built on a copper-plated (2 sides) Fiberglass circuit board measuring 4 3/4" X 8 1/2". The board is mounted on

an aluminum chassis measuring 5" X 9 1/2" X 2", which serves as a base and dust cover. Three copper partitions each measuring 4 1/4" X 1 1/2", divide the under-chassis area into four compartments of approximately equal size, as shown in the layout diagram of figure 15. The end compartments contain the nuvistor vhf converter and the 6360 linear-amplifier stage. The two interior compartments contain the local-oscillator chain and the 6360 mixer stage. Each partition is bolted to the circuit board with 4-40 hardware, and each has two feedthrough capacitors mounted at one end to pass filament and B+ connections. Placement of the major components may be seen in the photograph.

The first step in assembly is mounting the tube sockets and tuning capacitors to the board. Very small soldering lugs are placed under the socket hardware in order to ground the various socket pins and components, and nearby small phenolic tie-point strips are used to support small accessory capacitors and resistors.

It is suggested that a "mock-up" of the chassis be laid out before any drilling is done and then the larger components mounted in place while the builder experiments with placement of the smaller parts. Short leads are very important, and most of the components are mounted by their leads directly in the circuit, after lead length has been cut to a fraction of an inch. One compartment is wired at a time and should be tested before work progresses to the next compartment. It is suggested that the local-oscillator chain be assembled first.

The L.O. Chain—The 6AN8 oscillator/tripler and 6AK5 amplifier stages are wired

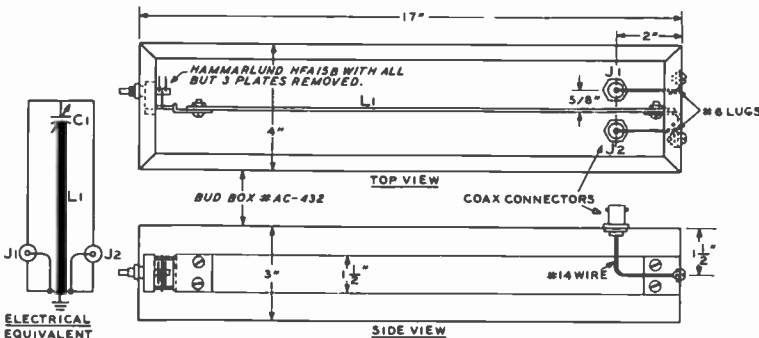

Figure 17
144-MHz HIGH-Q
CAVITY FILTER

first. The various bypass capacitors are mounted directly to the socket pins. Pins 3, 4, and 9 of the 6AN8 are grounded. The oscillator coil (L_1) is placed to the side of the tube socket and adjacent to it on a terminal strip is the 27K dropping resistor. The tripler coil (L_2) is airwound and self-supporting. It is placed between the terminal of the piston capacitor (C_1) and a nearby terminal strip.

The plate circuit of the 6AK5 tripler stage (C_2 - L_3) is placed on the far side of the socket, away from the tripler grid circuit. The zener diode (D_1) for the 6360 mixer stage is mounted on a tie point strip adjacent to coil L_3 . Once the 6AN8 and 6AK5 circuits have been wired, the circuits may be grid-dipped to frequency and the stages tested for operation. A 50-ohm, $\frac{1}{2}$ -watt resistor may be temporarily placed across the link coil of inductor L_3 to act as a load. A proper crystal is placed in the holder, along with the two tubes in their respective sockets. The voltage is applied and the stages are tuned for maximum output at 123 MHz. The output may be measured by a high-impedance d-c voltmeter wired in series with a 1N34 crystal placed at the "hot" terminal of the 50-ohm load resistor.

Once the oscillator/multiplier stages are operating, the crystal should be removed. The output of the stages should drop to zero. If a residual signal exists, it may indicate a fundamental-frequency oscillation in the 6AK5 amplifier stage. If such oscillation is noticed, a small copper shield placed across the 6AK5 socket should subdue the unwanted feedback. If instability still persists, plate coil L_3 of the 6AK5 should be rotated at right angles to the grid coil. In several transverters built to this plan, however, no sign of instability in the 6AK5 was noted, even without a shield placed across the socket.

The Mixer and Amplifier Stages—The next step is to wire the 6360 mixer stage. The 21-MHz balanced input circuit should be assembled carefully and then installed in the mixer circuit, since good balance is necessary in this assembly. The coil (L_4) is center tapped, with the two silver-mica capacitors mounted across the winding. In order to easily wind the coil, a length of wire is cut and a center tap placed at the

midpoint of the wire. The tap may be made by cleaning a short length of wire, then twisting it and soldering the tap. The two ends of the coil are then wound outwards, one side at a time, from the center point. After the coil is wound, the windings may be manipulated into proper tension and shape until they are symmetrical on the form. When the coil is completed and in place, the link winding is wound over the center of the coil.

The mixer plate coil (L_5) and amplifier grid and plate coils are self-supporting and are mounted to the stator terminals of the miniature split-stator capacitors. The coils are adjusted to 146 MHz with the tubes in the sockets and the capacitors about half meshed. Once the stage wiring is completed and the tank circuits checked, the transmitter portion of the unit may be tested with an external SSB signal.

Plate voltage is applied and the amplifier is coupled to a suitable dummy load. With no drive, amplifier plate current is about 20 milliamperes. A few volts of 21-MHz carrier is injected in the mixer receptacle J_1 (SSB *in*) and the 144-MHz frequency is monitored in a nearby receiver. The mixer plate circuit and amplifier circuits are peaked for maximum signal. The coupling between L_5 and L_6 should be loose, and care should be taken that the various circuits are tuned to 144 MHz and not to a spurious frequency. Drive level is advanced a bit and the linear amplifier may be loaded to about 50 milliamperes plate current. Care must be taken to avoid overdriving the mixer stage with the 21-MHz SSB signal. The maximum drive may be ascertained by viewing the 2-meter SSB signal on an oscilloscope. A condition of overdrive is indicated by flattening of voice peaks. Only two watts of drive, or so, is required, the greater percentage of driver output being absorbed in the dummy load at receptacle J_1 . Antenna coupling is adjusted, along with exciter microphone gain until proper amplifier operation is achieved, along with normal exciter loading.

The 6360 amplifier should be checked for stability. Normally, neutralization is not required. If instability is found, it may be corrected by soldering a $\frac{1}{2}$ -inch—long piece of insulated wire to each grid terminal of

the amplifier and passing each lead through a suitable hole drilled in the shield so that the lead reaches the proximity of the plate of the 6360. Since the 6360 has internal neutralization, auxiliary neutralization must be from plate to grid of the same section, rather than the more common cross neutralization.

The Nuvistor Converter—Once the transmitter section of the unit is adjusted, the converter may be aligned. The two 6360s are removed for this alignment. A 144-MHz test signal is injected into the converter from a nearby oscillator and the various converter tuned circuits are adjusted for maximum signal strength, as observed in the station receiver, which is used as an i-f strip. Once the converter is working, the tuned circuits should be readjusted for greatest margin of signal over noise, using a weak signal.

The next step is to properly neutralize the first 6CW4 r-f amplifier. The filament lead is removed from *pin* 12 of the *nuvistor* socket and the neutralizing coil (L_N) is adjusted for *minimum* strength of a weak signal. The filament lead is then reconnected. Optimum noise figure may finally be achieved by the use of a suitable noise generator.

Converter response is quite broad. The i-f output coil may be peaked at the center of the frequency range. The plate circuit of the r-f amplifier, (C_7 - L_9) should then be peaked near 145 MHz, and the detector grid circuit (C_8 - L_{10}) peaked near 147 MHz for flat frequency response across the 2-meter band.

The Strip-Line Filter A high-Q strip-line filter is useful in keeping the spurious responses of a transmitter from reaching the antenna. In addition, the filter will keep nearby high-power f-m and TV stations from overloading the converter, or from creating unwanted beats and birdies in the converter passband. Then, too, various high-power vhf signals may cause cross-modulation or mix with each other in the converter stages to produce annoying "ghost" signals. Good reasons exist, then, both in receiving and transmitting modes, for the incorporation of a strip-line filter after any 2-meter transmitter or receiver.

An easily constructed strip-line filter is shown in figure 17. The filter is essentially a closed cavity having a strip line in the center which is grounded at one end and tuned to resonance at the opposite end by a small variable capacitor. The incoming signal is fed into the cavity to a coupling loop which is grounded within the cavity. The circuit Q of the strip line is very high and currents circulating within the cavity are quite high at resonance. Current is induced in a similar coupling loop on the opposite side of the strip line, which is the output coupler. Since the filter is symmetrical, either loop can be used for input or output. The filter passes a very narrow band of frequencies with little loss, yet offers a very high impedance to all other frequencies off resonance.

The 2-meter strip-line filter is built within an aluminum box measuring 17" × 4" × 3". The strip line is made of aluminum sheet and measures about 16" long. It is bolted to one end of the box and attached to the variable capacitor at the opposite end. A shorter line and box may be used (down to 12" or so) but a larger capacitance will be required to achieve resonance. The line may be tested for resonance with a grid-dip oscillator. The coupling loops are about 2" long and are spaced 1/8-inch away from the strip line.

The filter should be connected to the transverter by a length of coaxial transmission one-quarter wavelength long. In the case of RG-8/U, the line will be 13.5" long. This length, or odd multiples of a quarter wavelength are recommended so as to provide proper input termination for the converter portion of the unit.

The filter may be tuned to frequency by placing an SWR meter in the line between the filter and the antenna. The filter is adjusted for maximum *forward* power reading on the bridge. Finally, adjust the transmitter output coupling for maximum forward power, as read on the bridge. Do not place the bridge between the filter and the transverter, since the presence of the bridge will alter the tuning of the filter when the bridge is removed. A bridge may be left permanently between the transmitter and the filter provided the electrical length of the bridge is taken into account when the

electrical quarter-wavelength of the line is established.

27-4 A 150-Watt PEP Linear Amplifier For 2 Meters

The power output of the transverter described in the previous section may be boosted appreciably by the addition of a suitable linear amplifier. Described in this section is a 150-watt PEP linear amplifier (figure 18) which can easily be driven by the transverter, or by any 2-meter SSB exciter having a PEP output of 2 watts or more. This amplifier is designed to use the

same voltages and currents required by many of today's h-f SSB transceivers or exciters. Thus, the station supply for a h-f transceiver may be borrowed and used with this unit. Operating with a plate potential of 800 volts, the 2-meter linear amplifier is capable of a PEP input of about 150 watts, but the unit may also be efficiently operated with a plate potential as low as 400 volts at reduced power level.

The Amplifier Circuit The schematic of the 2-meter linear amplifier is shown in figure 19. This is a push-pull circuit using a lumped-inductance grid tank and a parallel-line tuned-plate circuit. Two inexpensive 6146B tetrode tubes are



Figure 18

150-WATT PEP LINEAR AMPLIFIER FOR 2 METERS

Less than one cubic foot in size, this compact linear amplifier delivers a powerful signal for 2-meter DX operation. Rated at 150 watts PEP input, the unit requires less than 2 watts driving power.

Antenna tuning control and plate tuning adjustment are on main panel. The grid circuit is fixed-tuned to 146 MHz. One-inch miniature plate current meter has 100-microampere movement and is shunted to read 500 ma full scale. Amplifier is housed in perforated metal cabinet for maximum ventilation.

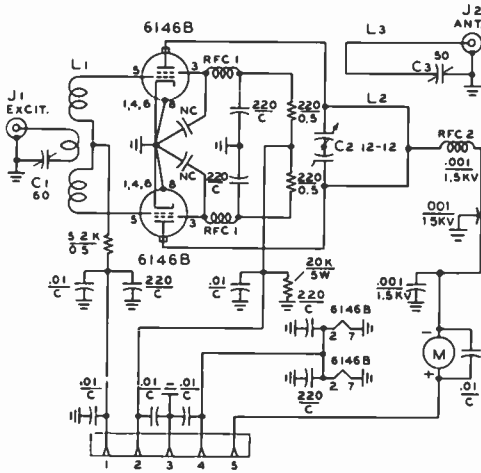

Figure 19

SCHEMATIC, 2-METER LINEAR AMPLIFIER

- C₁, C₂—60 pf, Centralab 822-AN or equiv. ...
- C₃—12-12 pf, Bud 355 or Hammarlund MFD-15X
- NC—60 pf, Centralab 822-AN
- L₁—4 turns #16, 3/8" diam., 1/2" long. Link coil is 2 turns #18 hookup wire.
- L₂—U-shaped inductor made of 3/16" copper tubing, about 4 1/2" long. Spacing is 3/4".
- L₃—U-shaped inductor, #12 wire, about 2 1/4" long, 1/2" wide
- RFC₁—0.8 μH. Ohmite Z-235
- RFC₂—1.8 μH. Ohmite Z-144
- Plate blocking capacitor—.001 at 1.5KV. Erie Filtron #1270-001
- Meter—0-500 ma d-c
- J₁—UG-290A/U coaxial receptacle
- J₂—UG-58A/U coaxial receptacle
- P₁—Cinch-Jones P-306-AB

used in a neutralized configuration, providing good stability and high efficiency at modest cost.

Tubes of the 6146 category have rather high interelectrode capacitance and appreciable lead inductance. Allowance for these factors must be included in the circuit design. The effective input capacitance of two 6146Bs in push-pull is about 7 pf, plus the additional socket and lead capacitance to ground. Grid-circuit tuning is not required, especially if the exciting link winding of the drive circuit is series tuned in the proper manner. The effective plate-circuit output capacitance, while less than that of the grid circuit, is still about 4 pf. This, plus the minimum capacitance of the plate-tuning capacitor, raises the Q of the plate line cir-

cuit to a value greater than normally would be desired. By proper design of the plate line, however, this difficulty is overcome and good plate-circuit efficiency is achieved in a small space.

The self-neutralizing frequency of a 6146B tube is lower than the 2-meter band and thus some form of neutralization is necessary to achieve good amplifier stability. A simple and effective method of neutralizing an amplifier operating in this frequency region is to employ series screen neutralization, wherein the screen circuit is adjusted so as to establish a low impedance to ground on the screen structure within the tube. This circuit is frequency sensitive, and a sharp neutralization null may be obtained at one operating frequency by proper choice of the screen capacitor. If the amplifier is properly shielded and the power leads adequately filtered, the unit may be neutralized at the middle of the 2-meter band and the intra-stage isolation will remain sufficiently high so that stable operation takes place over the entire band without the need for reneutralization at the band edges.

Since r-f voltage appears on the screen terminal of the tube, it is necessary to use a screen isolation circuit made up of an r-f choke and isolation resistor. In order to establish r-f ground at the screen, filament, and grid circuits, series-resonant 220-pf disc ceramic capacitors are used as bypass elements. In addition, the power leads are bypassed with .01-μfd disc capacitors to make sure these leads remain free of low-frequency energy that may be coupled into the amplifier from the exciter stages.

The plate circuit of the push-pull amplifier is conventional, utilizing a series-tuned loop for the antenna circuit. The rotor of the split-stator tank capacitor is left floating so that the circuit may assume its own electrical balance to ground.

Amplifier Layout and Assembly The 2-meter linear amplifier is built within an aluminum chassis measuring 9 1/2" × 5" × 2 1/2" which serves as an r-f inclosure and dust cover. A 3 1/2" × 4" cutout in the chassis above the tubes is covered with perforated metal to permit proper tube ventilation while still preserving the electrical continuity of the inclosure.

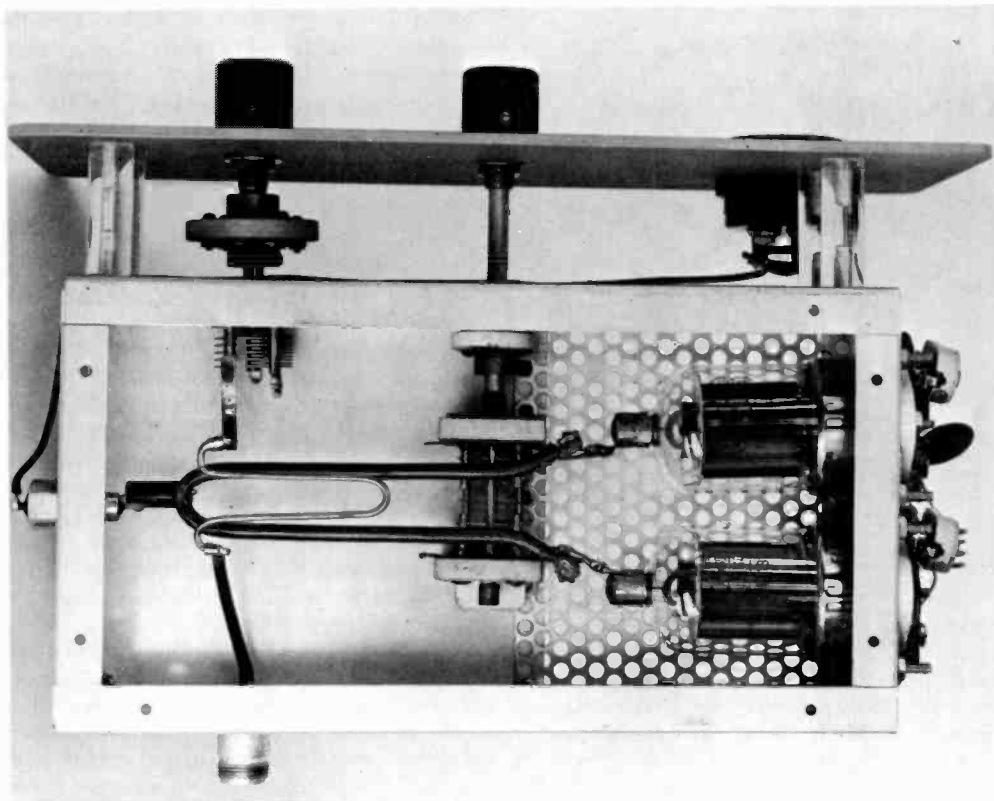

Figure 20

UNDER-CHASSIS VIEW OF AMPLIFIER

Amplifier chassis is mounted to panel by four spacers and tuning capacitors are driven through insulated, flexible couplings. Rotor of plate tuning capacitor is "floating" above ground. High-voltage plate circuit feedthrough capacitor is mounted to chassis at left, with plate r-f choke seen below end of plate line. The antenna pickup loop is supported from stator of antenna tuning capacitor and antenna receptacle. Grid and screen circuit components of 6146Bs are mounted to end of chassis, at right. Perforated bottom plate is attached to bottom of chassis with sheet metal screws.

A bottom plate of perforated metal is placed over the open side of the chassis. Since plate dissipation may rise as high as 50 watts for the two tubes, it is essential that cooling air circulate freely within the inclosure, or tube life will suffer.

The perforated metal cabinet measures $11\frac{1}{4}'' \times 5'' \times 9''$ and was obtained from an obsolete "hi-fi" amplifier. A suitable metal cabinet of the same general size may be used, provided it is adequately ventilated.

A general view of parts placement may be seen in the interior photograph of figure 20. The two 6146B tubes are mounted on one

end of the chassis, with the remaining interior space taken up by the tuned plate line and antenna coupling circuit. Grid and screen components are mounted on the outer end wall of the box. At the opposite end of the assembly, the high-voltage lead is passed from the plate circuit via a low-impedance, high-voltage feedthrough capacitor mounted in the wall of the box.

In order to reduce lead inductance to a minimum, the 6146B sockets are mounted to the chassis in a special way. The sockets used are ceramic and have the terminals riveted in place, the head of the rivet being

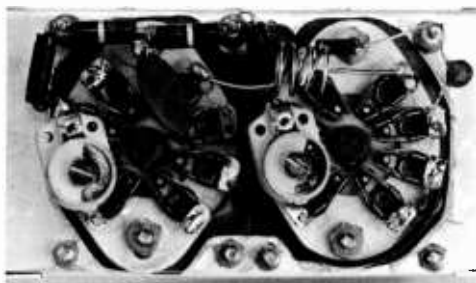

Figure 21

6146B SOCKET ASSEMBLY

Ceramic sockets are bolted to copper plates fitted into cutout in aluminum chassis. Socket grounds are made by soldering assembly rivets to copper plate. Twin ceramic neutralizing capacitors are at center, with screen chokes and isolating resistors at top of assembly.

recessed in a small shallow spot atop the socket. Eight such spots exist, one for each rivet head. When the socket is mounted beneath a metal deck, the shortest ground path for any individual tube pin is through the rivet to the deck above. Accordingly, each socket is mounted on a 2¼" X 2" copper plate having a 1" diameter hole cut in the middle that will pass the tube base. The edge of the center hole passes within a fraction of an inch of the various rivets that hold the socket terminals in place. It is a simple job to solder a short, heavy jumper made of thin copper shim stock from the rivets of socket pins 1, 4, 6, 7, and 8 to the copper mounting plate. Two such plate-and-socket combinations are prepared, and the plates are bolted over a cutout at the end of the aluminum chassis (figure 21).

The remainder of the grid and screen wiring is placed on the prepared sockets. The small ceramic variable screen-tuning capacitors (NC) are soldered by their leads between *pin 3* and *pin 1* of each tube socket. The grid coil (L_1) is self-supported between the #5 pins on each socket, while the screen r-f chokes, bypass capacitors, and isolating resistors are mounted to adjacent socket pins and nearby tie-points.

The Plate Circuit The complete plate circuit may be assembled and

tested as a unit before it is placed in the shielded inclosure. The plate line (L_2) is bent from a single length of copper tubing. In order to prevent the tubing from flattening as it is bent, it should be filled with dry sand and the ends crushed. It is prudent to make the line a bit longer than necessary. The mid point of the line is marked, and the tubing is bent around a ¾-inch-diameter form. The ends of the tubing are now trimmed to form the U-shaped inductor about 5" long, and the sand is removed from the line.

It may be necessary to attach short extension straps of copper shim stock to the lugs of the two stator sections of the variable capacitor. These leads join the capacitor sections to the line, and also to the 6146B plate caps. Inexpensive receiving-type caps are used for the tubes, and short stout leads should be used to connect the caps to the capacitor terminals. At this point, lead inductance is very critical.

The complete tank circuit may be assembled in place to ascertain the proper spacing and alignment between the plate caps and the capacitor. When completed, the unit may be removed and tested with a grid-dip oscillator. Without the tubes, and with the assembly in the clear, resonance should be found at about 190 MHz with the capacitor fully meshed. With tubes in place and the line inside the box, the tuning range should cover 140 MHz to 150 MHz, or better. The final tuning range may be varied slightly by altering the length of the strap connections to the plate caps of the 6146Bs.

The plate r-f choke (RFC₂) is mounted so that the choke body is parallel to the plate line and outside the end of it, in order to reduce inductive coupling between the choke and plate line to a minimum.

The antenna loop (L_3) is made of a section of heavy copper wire and is supported at the ends from the antenna receptacle (J_2) and antenna tuning capacitor C_3 . Length of the loop may have to be determined by experiment as it is critical as to the SWR on the antenna system.

Before the amplifier is tested, a bottom plate made of perforated metal should be attached to the chassis with sheet-metal screws to complete the r-f inclosure.

Testing the Linear Amplifier The first step in adjusting the amplifier is to place the tubes in their sockets and grid-dip the grid coil to about 146 MHz. Adjustment may be accomplished by expanding or contracting the coil length. The amplifier may be neutralized "cold" by applying a small amount of excitation to the grid circuit and measuring the r-f output in the antenna circuit after both plate and antenna circuits have been resonated. The screen neutralizing capacitors are adjusted until the feedthrough energy is reduced to a minimum. The output voltage may be monitored with a 1N34 diode and a high impedance d-c voltmeter. Both screen capacitors are adjusted in unison to produce a deep null in measured feedthrough power. The actual capacitance of the neutralizing setting at proper null is of the order of 15 pf or so.

Once the amplifier has been properly neutralized, bias, screen, and plate voltages may be applied as summarized in figure 30, Chapter 16. The bias voltage is adjusted for the proper resting value of d-c plate current and a suitable dummy load or antenna is connected to the amplifier. Adjustment is much the same as with any low-frequency amplifier. The input link tuning capacitor (C_1) is adjusted for maximum output with minimum drive, and the antenna tuning control (C_2) and coefficient of coupling between the plate circuit and antenna loop are adjusted for maximum power output at a given input level. Drive level and loading may be increased in stages as screen and plate currents are monitored.

When the amplifier is properly loaded, neutralization may be checked by detuning the plate circuit of the amplifier. Screen current should drop off evenly on either side of resonance. In addition, removing excitation should permit the amplifier plate current to drop to the static level. A sure sign of regeneration is uneven distribution of screen current, possibly rising sharply on one side of plate-circuit resonance, and dropping sharply on the other side of resonance. A small adjustment to one or the other screen neutralizing capacitor will correct this unbalance.

The size of the antenna coupling loop and the spacing between it and the plate line depends to some extent on the termination

presented to the amplifier by the antenna system. The loop should be at least $\frac{1}{8}$ -inch from the plate line so as to prevent flash-over from the line to the loop. If sufficient coupling cannot be achieved, the loop should be increased in length. If the coupling is too heavy, the length of the loop may be reduced.

Once proper coupling has been achieved and the amplifier neutralized, it will perform in the same manner as a similar unit operating on the lower-frequency bands. While no provision has been incorporated for balancing the tubes under full load, it will be found that if unbalance exists, the anode of one 6146B will tend to run hot at full input when viewed in a dark room. Balance may be altered by altering the spacing of one side or the other of the grid inductor until both tubes load evenly.

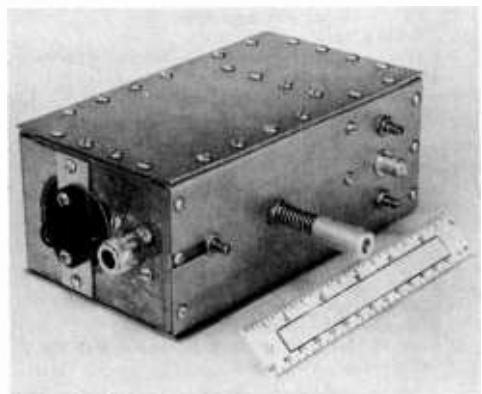

Figure 22

**432-MHz TRIPLER/AMPLIFIER
USING 4X150A OR 4CX250B**

This compact unit functions either as a tripler to 432 MHz, or as an amplifier on that band. It uses an external-anode tetrode in a modified cavity plate circuit. Inclosure is made up of side pieces held together with sheet-metal screws or "pop" rivets. In this oblique view, the B-plus connector is at the left side of the unit, with the coaxial antenna receptacle immediately adjacent to it. The antenna tuning capacitor is mounted to the end piece of the box, which may be removed by loosening the holding screws and the capacitor nut. At the center of the box is the spring-loaded tuning capacitor and at the right end is the coaxial input receptacle and the input tuning capacitors.

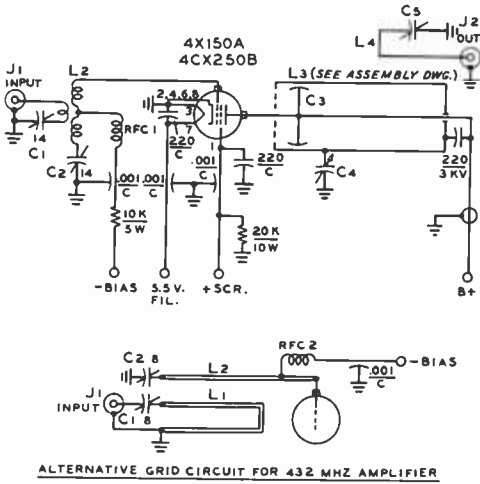

Figure 23

**SCHEMATIC—432-MHz
TRIPLER/AMPLIFIER**

- C₁, C₂, C₃—14 pf, Johnson 160-107
- C₄, C₅—See text
- Note: Use 8 pf, Johnson 160-104 for 432-MHz alternative grid circuit
- L₁—1 turn hook-up wire, 3/4" diam, inside L₂ (432 MHz)
- L₂—3 1/2 turns #14, 1" diameter, 3/4" long (432 MHz)
- L₃—See text
- L₄—3/8"-wide copper strap form inductor 3/8" long X 1/8" high
- RFC₁—1.7 μH. J. W. Miller RFC-144, or Ohmite Z-144
- RFC₂—0.2 μH. J. W. Miller RFC-420, or Ohmite Z-420
- J₁—Coaxial receptacle. UG-290A/U
- J₂—Coaxial receptacle. UG-58A/U
- Blower—6 cfm at 0.4" back pressure. Use #2 1/2 impeller at 6000 r.p.m.

**27-5 A Tripler/Amplifier
For 432 MHz**

An efficient tripler or amplifier for 432-MHz operation may be designed around the 4X150A or 4CX250B external-anode tetrode. Rated at 250 watts anode dissipation (the late production 4X150As also have the higher rating) this high-perveance tetrode is one of the few tubes that performs well as a tripler from 144 MHz or as a straight amplifier at 432 MHz. A power output of better than 60 watts may be obtained as a tripler, and over 200 watts output may be achieved in amplifier service.

Two units such as described may be built; one acting as a tripler to drive the second one as an amplifier at a power input up to 500 watts.

The Tripler/Amplifier Circuit The general schematic of the amplifier is shown in figure 23. An easily built coaxial plate-tank circuit provides high efficiency at 432 MHz and the unit operates in the same manner as if it were on the lower-frequency bands. The circuit consists of a short, loaded resonant cylindrical line which uses the amplifier case as the outer conductor. Plate voltage is fed through the line to the anode of the tube, which is insulated from the cylindrical line by means of a thin *teflon* sheet wrapped about the anode.

For tripler service, the grid circuit is tuned to 144 MHz, with the input capacitance of the tube and tuning capacitor C₂ forming a balanced tank circuit. The isolation choke (RFC₁) is at the center, or "cold" point of the grid inductor. A series-tuned link circuit couples the unit to the external exciter.

In amplifier service, the grid circuit is tuned to 432 MHz and takes the form of a half-wavelength line, tuned to resonance by a small capacitor placed at the end of the line opposite the tube.

A special air-system socket designed for the external-anode tetrode must be used. For tripler service, the builder has the choice of either the EIMAC SK-600, SK-610, SK-620, or SK-630 socket, together with the appropriate air chimney. The SK-606 chimney is to be used with the SK-600 or SK-610 socket, and the SK-626 chimney is to be used with the SK-620 or SK-630 socket.

For amplifier service at 432 MHz only, the EIMAC SK-620 or SK-630 sockets are recommended, as the other versions have screen terminals exposed to the plate-circuit field and exhibit more r-f feedthrough than do the suggested sockets, which have shielded screen terminals. Using the proper sockets, intrastage feedthrough at 432 MHz is sufficiently low so that stage neutralization is not required under normal, loaded operating conditions.

Not shown in the schematic is the fact that an external centrifugal blower is re-

quired to adequately cool the filament and plate seals of the external anode tube. Approximately 6.4 cubic feet per minute of cooling air at a pressure drop of 0.82 inches of water is required for full, 250-watt anode dissipation. For operation at reduced voltages and a limitation of 150 watts dissipation, the cooling-air requirement is 3.4 c.f.m. at a pressure drop of 0.15 inches of water.

At a frequency of 432 MHz, cathode backheating is observed in tubes of this type, and to maintain proper cathode temperature, the filament voltage should be reduced to 5.5 volts and held within plus or minus five percent of this value.

Finally, it should be noted that under certain operating conditions, the screen current of a tetrode may become negative. In order to protect the tube from excessively high screen voltage under certain negative-current conditions, it is mandatory to connect a bleeder resistor at the tube that will draw a value of current greater than drawn by the tube under negative-current operating conditions.

Tripler/Amplifier Construction The tripler/amplifier is constructed within a metal box measuring 7" \times 2 $\frac{3}{4}$ " \times 2 $\frac{5}{8}$ ". The top and bottom of the box are flat pieces of aluminum or brass measuring 7" \times 2 $\frac{3}{4}$ ". The two side pieces are identical in size with matching holes for sheet-metal screws. Each side has small flanges along the edge which match the sides to the top

and bottom pieces. The end section of the box which makes up the plate-circuit assembly is made of brass so that the brass quarter-wavelength plate line may be soldered to it. The opposite end of the box has a hole drilled off center in it to accept a fitting for an air hose or blower orifice (figure 24).

The plate line is made of a 3 $\frac{3}{4}$ " length of brass tube having a 1 $\frac{1}{4}$ " outside diameter. The line is soldered to the brass end to accept the anode of the 4X150A or 4CX250B.

An internal partition separates the grid and plate circuits and supports the socket for the tetrode. The socket is bolted atop the partition, as shown in figure 24. Connection is made to the anode for the supply voltage by means of an extension shaft run from the high-voltage connector mounted on the top plate of the box. The shaft has a section of spring steel bolted at the end to make a press fit to the top of the anode of the tube.

The plate-blocking capacitor is made of a length of 3-mil *teflon* tape, wrapped twice around the tube anode. The tape is cut to a width of one inch to allow overlap on both sides of the anode. The tape is carefully wrapped around the metal anode before the tube is pressed into the open end of the plate line, as shown in figure 26.

The top plate of the box, in addition to the plate-line and high-voltage connector, supports the antenna receptacle (J₂) and the series antenna-tuning capacitor. The antenna

Figure 24

INSIDE VIEW OF TRIPLER/AMPLIFIER

Tetrode tube socket mounts on small partition placed across interior of box. Plate-tuning capacitor and antenna capacitor are at right of assembly. The anode line of the 4X150A (4CX250B) is slotted and slips over the tube, insulated from it by a teflon wraparound insulator. B-plus passes down through the tube to a spring that makes connection to the anode. Below the partition are the grid circuit and various bypass capacitors. Power leads pass through feedthrough capacitors mounted in the rear wall of the enclosure (left). Aluminum fitting at the bottom of the box matches air-hose connection to external centrifugal blower. Blower should be turned on when filament voltage is applied to the tube.

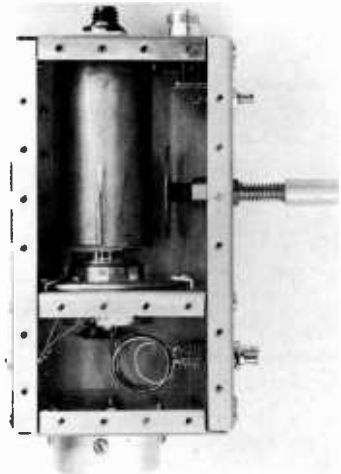

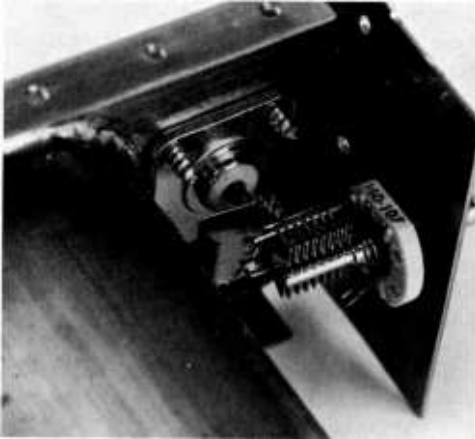

Figure 25

CLOSEUP OF ANTENNA CIRCUITRY

Small series-tuned loop is made of copper strap connected between coaxial output receptacle and stator rods of antenna tuning capacitor. Coupling is adjusted by setting of capacitor, and link is fixed about 1/8-inch away from plate line. Plate line is soldered to brass end plate.

pickup loop (L_4) is soldered between the receptacle and the stator of the capacitor, and is spaced away from the plate line about $\frac{1}{8}$ inch.

Plate-tuning capacitor is a $1\frac{3}{4}$ " disc made of brass material soldered to the smooth end of a shaft that is threaded to match a panel bushing. The outer portion of the shaft is $\frac{1}{4}$ -inch diameter to fit the dial drive. Tension is maintained on the shaft and bearing by placing a spring between the shaft extension and the panel bushing, as shown in the side view photograph. Note: An assembly drawing of the plate circuit may be obtained at no cost by writing: Amateur Service Dept., EIMAC Division of Varian, San Carlos, Calif. 94070.

Tripler/Amplifier Operation

After the unit has been assembled, it should be tested for operation at reduced voltages. The first step is to grid-dip the input and output circuits to resonance to make sure they tune properly. An r-f output meter or SWR bridge should be used in conjunction with a dummy load for the initial tests. A good dummy load for 432

MHz is 500 feet of RG-58/U coaxial cable. The far end should be shorted and waterproofed and the cable may be coiled up in a tub of water.

As with any tetrode, plate current is a function of screen voltage, and screen current is a function of plate loading. Screen voltage, therefore, should never be applied before plate voltage, and screen current should be monitored for proper plate loading. The amplifier should never be tested or operated without a proper dummy load.

To operate as a tripler, the following electrode voltages are suggested: plate voltage, 1000; screen voltage, 250; grid bias, -90 volts. The bias may be obtained from a small voltage-regulator tube or zener diode. Cooling air is applied with filament voltage which should be 5.5 volts. When these voltages are applied to the tube, plate current will be near-zero with no drive, and the screen current will be about 10 milliamperes, or less. The screen current noted will be the sum of the positive current flowing through the bleeder resistor and the negative screen current of the tube.

A small amount of excitation at 144 MHz is applied and the grid circuit resonated, as noted by a small rise in plate current. The plate circuit should be brought into resonance. Excitation is boosted, and the tripler tuned for maximum power into the dummy load. Loading and grid drive may be increased until a plate current of 250 ma is achieved. At this level, total screen current will be about 15 to 20 ma, and grid current will be about 12 ma. Power input is about 250 watts and power output, as measured at the antenna receptacle with a vhf wattmeter is about 70 watts. Over-all tripler efficiency is about 28 percent and plate dissipation is nearly 180 watts.

Screen current is a sensitive indicator of circuit loading. If the screen current falls below 10 to 12 ma (including bleeder current), it is an indication that plate loading is too heavy or grid drive too light. Screen current readings of over 30 ma indicate drive is too heavy or plate loading is too light. A plate voltage as low as 800 volts may be used on the tripler stage, with an output of about 55 watts at a plate current of 250 ma. Plate voltages below this value are not recommended as screen current starts to

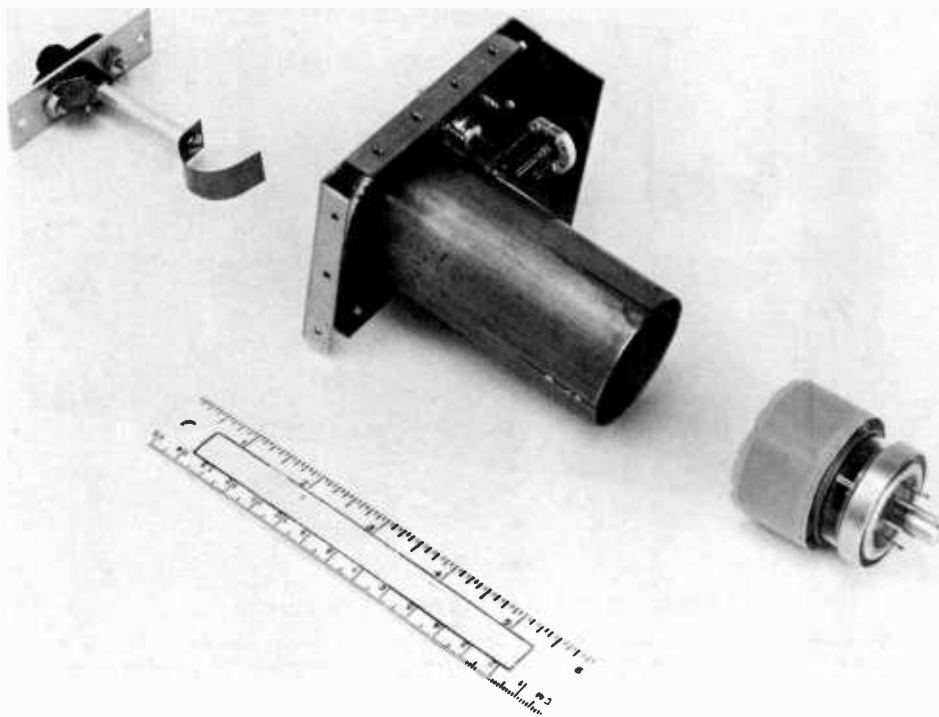

Figure 26

EXPLODED VIEW OF PLATE-LINE ASSEMBLY

The high-voltage receptacle, plate bypass capacitor, and anode connector spring are at left. The brass end plate of the box and plate-circuit assembly are at the center, with the 4X150A tetrode at the right. The tube anode is wrapped with teflon tape to form a bypass capacitor, removing the d-c voltage from the coaxial line. Copper line makes press fit over the anode of the tube.

climb rapidly at low plate potentials. For amplifier service, the alternate grid circuit is employed. The amplifier may be operated either class C or class AB₁. Operating data for both classes of service are given in the 4X150A data sheet.

27-6 A 175-Watt SSB Exciter

Building a single-sideband exciter or transmitter is simpler and less expensive than construction of a-m equipment of

equivalent power rating. Physically, the SSB exciter can be made more compact and lighter in weight for an equivalent degree of "talk power" as compared to the a-m equipment. Only the simplest of test equipment is required and the use of a commercial crystal sideband filter in the exciter eliminates critical circuit adjustment and tinkering.

The exciter described in this section (figure 27) is of a proven design and is recommended to those experimenters wishing to build their first piece of sideband transmitting equipment.



Figure 27

SIDEBAND EXCITER PACKS PLENTY OF PUNCH

This custom-built exciter provides 175 watts PEP input for SSB or c-w operation between 3.5 and 29.5 MHz. The homemade cabinet is spray painted light gray while the panel is painted two-tone gray. The main tuning dial is to the right of the slide-rule dial plate assembly. The three controls below the dial are (l. to r.): r-f level (R_1), amplifier plate tuning (C_{11}), and amplifier loading (C_{12}). The band-selector switch is centered below the plate tuning control, with the grid tuning control (C_2) and key jack on opposite sides. At the lower left is the sideband-selector switch (S_1) with the carrier-injection potentiometer (R_2 - S_2) directly underneath. Audio gain control (R_3) is above the microphone jack. The a-c power switch is at the far right, next to the three-position function switch (S_3). Bandswitch has two ten-meter positions for two 500-kHz segments.

The Exciter Circuit

This filter-type exciter incorporates all the desirable features of more expensive exciters, covering the amateur bands between 10 and 80 meters with a minimum of controls and adjustments. The output stage utilizes a pair of highly linear 6550 tetrode tubes run at a PEP input of about 175 watts. A block diagram of the exciter is shown in figure 28.

The sideband generator is designed around a 9-MHz crystal lattice filter and consists of a 7360 oscillator/balanced modulator (V_7) with a 12AX7 speech amplifier (V_1) modulating one deflection plate of the 7360. The filter drives a 6BA6 i-f amplifier stage (V_2) to bring the signal up to the proper mixing level. Two carrier crystals in the grid circuit of the 7360 oscillator section permit sideband selection.

The 9-MHz SSB signal is coupled to the #2 grid of a 6BA7 mixer (V_8), and here it is combined with the 5.5- to 5.0-MHz output of a very stable vfo. The difference product of these two signals is used as the basic exciter frequency range of 3.5 to 4.0 MHz, which appears in the plate circuit of the mixer stage. All the higher amateur bands are derived by mixing this SSB signal with an auxiliary crystal oscillator. The output from the 6BA7 mixer is bandpass coupled to a 12BY7A (V_3) which operates as an amplifier on the 80-meter band and as a second mixer for all the higher-frequency bands. The mixing oscillator is a 6C4 (V_{10}) whose output is always higher in frequency than the desired mixer product. A second 12BY7A (V_4) serves as the driver stage for the two parallel connected 6550 tetrode

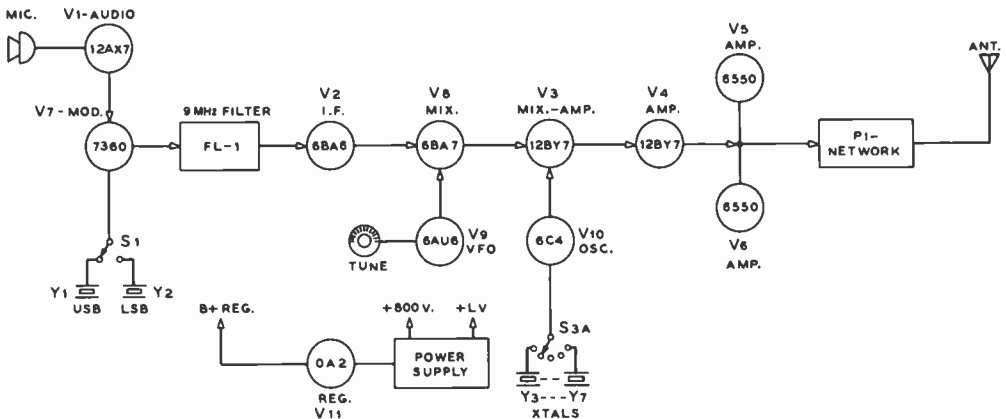

Figure 28

BLOCK DIAGRAM OF THE SSB EXCITER

A 9-MHz crystal lattice filter and 7360 oscillator/mixer simplify circuitry and provide superior results in this compact SSB exciter. Covering the amateur bands between 80 and 10 meters, the exciter utilizes two low-distortion type 6550 tubes in the linear amplifier stage. A double-conversion circuit is used, with the vfo covering the range of 5.5 to 5.0 MHz for 80-meter operation. A second, crystal-controlled conversion oscillator mixes the SSB signal for operation on the higher-frequency bands. A solid-state power supply provides all d-c voltages for the exciter.

amplifier tubes. The measured third- and fifth-order distortion products of these tubes under the given operating parameters run better than 30 decibels below one tone of a two-tone test signal.

Spurious products are reduced by incorporation of a low-pass filter (L_4 , L_5 , and associated capacitors) in the output circuit of the vfo stage to suppress the second and higher order harmonics of the oscillator.

The exciter is activated by two relays which are energized by a push-to-talk switch on the microphone. All tuning adjustments are accomplished with a single meter that measures the cathode current of the final amplifier, plus an auxiliary grid-current meter. A three-position *function switch* (S_7 A-B) enables the operator to zero-in on a chosen frequency without placing an interfering signal on the air or without disabling his receiver. The *zero* position of switch S_7 also disables the microphone circuit so that the exciter cannot be accidentally turned on in this mode. A second position (c-w) of the function switch provides c-w operation (with carrier injection) and the third position (PTT) places the exciter in readiness for push-to-talk voice operation.

Exciter Layout The general layout of the exciter may be seen in the various photographs (figures 30 and 32). An 11" × 17" × 3" steel chassis is used for the foundation. The final amplifier assembly above the chassis is inclosed in a three-sided inclosure measuring about 7½" long by 4½" deep by 6" high. The sides are made from perforated aluminum sheet. A two-sided L-shaped aluminum dust cover completes the inclosure.

Under the chassis, the vfo components are inclosed in a U-shaped shield made of light aluminum sheet measuring about 4" square and 2¾" high. The tuned circuits and 6AU6 socket are mounted on a heavy ⅛" thick aluminum plate measuring 4" × 5" mounted atop the chassis above the aluminum shield. The shield has ¼" lips bent on all sides to fasten it to the chassis and to the side apron of the chassis. The balanced modulator and speech amplifier tubes are at the opposite end of the chassis, and their under-chassis components are contained within an L-shaped aluminum inclosure at the panel.

The final amplifier tube sockets are mounted on a sheet of perforated aluminum

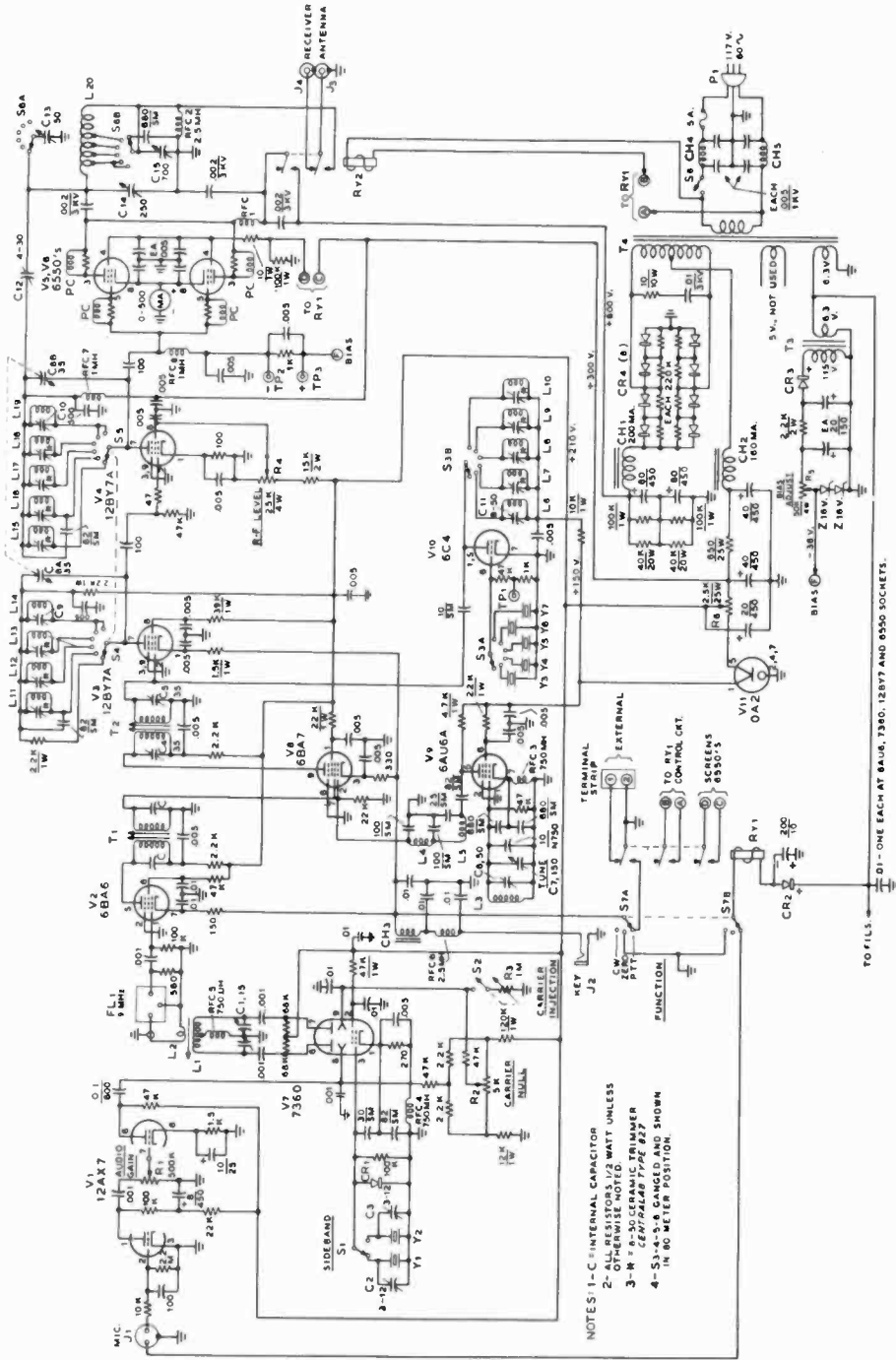

Figure 29
 SCHEMATIC, 175-WATT SIDEBAND EXCITER

PARTS LIST FOR FIGURE 29

C_1 —15-pf differential capacitor. Johnson 160-308	PC —Parasitic suppressor. 100-ohm, 1-watt resistor, wound with 4 turns # 18 enam.
C_2, C_3, C_4, C_{10} —12-pf ceramic capacitor. Centralab 822	RFC_1 —2.5 mH, 300 ma. National R-300U
C_5, C_6 —35 pf Hammarlund MAPC	RFC_2, RFC_3 —2.5 mH, 100 ma. National R-100
C_7, C_8, C_9 —50 pf Hammarlund APC	RFC_4, RFC_5, RFC_6 —750 μ H. National R-33
C_{11} —150-pf tuning capacitor from ARC-5 transmitter	RFC_7 —1 mH, 100 ma. Miller 4652
$C_{12}A-B$ —35-pf Hammarlund APC ganged with insulated coupling	S_1, S_2, S_3, S_4 —Bandswitch. Four Centralab PA-2 ceramic decks, each two-pole six-position, with index Assembly PA-301
C_{13} —50-pf ceramic capacitor. Centralab 827	T_1 —10.7-MHz i-f transformer (tune to 9 MHz). Miller 1463
C_{14} —30-pf ceramic capacitor. Centralab 822	T_2 —Bandpass transformer (3.5–4.0 MHz). See figure 13B
C_{15} —50-pf APC padder for 3.5 MHz	T_3 —6.3 volts, 1 ampere. Wire in reverse
C_{16} —250-pf, 0.024" spacing. Bud 1859	T_4 —800-volt c.t., 200 ma; 6.3 volt, 5 ampere; Stancor PC-8412
C_{17} —365-pf per section. Miller 2112	Y_1 —8998.5 kHz (McCoy)
CR_1 —1N34A	Y_2 —9001.5 kHz (McCoy)
CR_2, CR_3 —1N1695 (400-v. PRV, 600 ma)	Y_3 —11.000 MHz for 40-meter operation
CR_4 —Eight diodes, four per leg. 1N4005 (600-v. PRV, 1 amp)	Y_4 —18.000 MHz for 20-meter operation
CH_1 —5H, 200 ma. Stancor C-1646	Y_5 —25.000 MHz for 15-meter operation
CH_2 —5H, 150 ma. Stancor C-1710	Y_6 —32.500 MHz for 10-meter operation (28.5–29 MHz)
CH_3 —Low-inductance choke (primary winding of 50L6 output transformer)	Y_7 —33.000 MHz for 10-meter operation (29.0–29.5 MHz)
CW_1, CH_4 —Line filter choke. Miller 5218, or 18 turns # 16 o. $\frac{3}{4}$ " diameter, $1\frac{1}{2}$ " long	Z —18-volt, 1-watt zener diode. 1N4746A
MA —0-500 d-c milliammeter. Simpson 2" Wide-vue	Note: Bandswitch has two 10-meter positions.

which is bolted above a cutout in the chassis to permit good circulation of air past the sockets and envelopes of the tubes. The leads from the tap on the amplifier plate coil (L_{20}) pass down through a slot cut in the chassis to the ceramic bandswitch segment (S_6A-B) which is driven by the main bandswitch assembly. The switch segment is fastened to the back apron of the chassis and is connected to the bandswitch by a phenolic shaft extension.

A small U-shaped aluminum shield is placed across the center of the 6550 sockets to isolate the plate parasitic chokes and leads from the nearby grid wiring. To minimize heat under the chassis the 40K, 20-watt, high-voltage bleeder resistors are mounted in a vertical position above the chassis by means of a long bolt placed vertically in the rear corner of the final amplifier inclosure. The 650-ohm, 25-watt resistor in the B-plus voltage dropping network is mounted in the same manner to the outside of the amplifier inclosure near the high-voltage filter choke.

The most critical assembly of any good SSB exciter is the vfo which must have rigid construction and use the best available parts for the job. Silver mica padding capacitors, a ceramic tube socket and a precision tuning capacitor ensure the stability

of this unit. The tuning capacitor is taken from the amplifier section of a "surplus" AN/ARC-5 (SCR-274N) transmitter (any model). It has wide plate spacing, glass bead insulation, and a smooth worm-gear drive that lends itself very nicely to the assembly of a simple home-made slide rule dial. The vfo coil is a section of *miniductor* stock securely cemented to a $\frac{1}{4}$ " thick square of *plexiglas* which is solidly mounted on two ceramic pillars inside the vfo shield compartment. The coil is placed to one side of the chassis away from sources of heat.

The Main Bandswitch Assembly The assembly details of a typical bandswitch and coil section are shown in figure 31A. The coils and associated padding capacitors are preassembled to the shield plate and wired before the plate is mounted to the chassis. Although the bandswitch shaft is positioned along the centerline of the chassis, the switch wafers are placed slightly off center on the partition (see illustration) to allow space for the ganged APC capacitors (C_8A-B). These capacitors are insulated from the partition (ground) and from each other, and are ganged with insulated flexible couplings

to the panel control. As each set of coils is identical for any one band and is wired to the switch section in an identical manner on each partition, a satisfactory degree of tracking is achieved by the use of parallel padding capacitors. These capacitors are mounted near the top lip of each shield partition. The crystal oscillator coils are mounted on the front side of the partition nearest the panel, with leads from the switch wafer left long enough to be attached to the tube and crystal socket beneath the bandswitch catacomb.

The Dial Assembly The slide-rule dial is patterned after a "short-wave style" dial and is made from a flat plate of aluminum mounted to triangular brackets that fasten it to the chassis. The center of the plate is cut out leaving a rectangular hole, and a sheet of clear *plexiglas* (spray-painted white on the front) is fastened to the rear of the plate with 4-40 bolts or "pop" rivets. A slider moves along the smooth top edge of the plate and carries the pointer over the dial face. A dial cord is attached to a drum mounted on the large gear of the vfo tuning capacitor and drives the pointer via small dial pulleys taken from an obsolete slide rule dial. As the gear moves almost 360 degrees for 180 degree rotation of the capacitor, a 2½" diameter drum will provide almost 7" of pointer travel. The dial cord passes around the bottom of the dial face on idler pulleys placed at the corners, then back to the vfo cord drum.

Wiring and Testing the Exciter It is prudent to wire the exciter in sections and to get one section at a time in working order before proceeding to the next section. It is suggested that the speech amplifier, 7360 stage, and 9-MHz amplifier be wired and tested first. The next step would be to wire and test the vfo, first mixer, and 12BY7A amplifier. An auxiliary power supply can be utilized for these tests. Next, the crystal oscillator, driver, and final amplifier stages are wired and tested, followed by completion of the power-supply and control wiring. If the power transformer is not mounted until the last step, it will

be quite simple to move the unit about as the weight of the exciter (less the transformer) is quite small.

After the exciter is assembled and wired, a voltage check should be made. The schematic shows various voltages derived from the B-plus divider network. The no-load high voltage is approximately 800 volts, dropping to about 750 volts with a 200-ma load. The 12BY7A driver tube operates at 300 volts, as do the screens of the 6550 tubes. The vfo and crystal oscillator receive regulated voltage from the OA2, and all other stages are supplied from the 210 volt tap of the supply network. Bias for the final amplifier is regulated at -36 volts by means of the zener diodes.

Oscillator Alignment—The vfo may be adjusted to the 5.5- to 5.0-MHz range by loosely coupling it to the station receiver and checking the tuning range against the receiver. The values of inductance and capacitance given for the vfo-tuned circuit allow slightly more than 500-kHz coverage and the optimum frequency placement on the main tuning dial is done by adjusting the padding capacitor (C_6) in the oscillator circuit.

The conversion oscillator is adjusted by proper tuning of the plate circuit, checking oscillation with a low-range voltmeter placed at the test point (TP₁) in the grid circuit of the 6C4 oscillator. The upper or lower sideband is selected by *sideband switch* S_1 and the trimmer capacitor across the crystal in use is adjusted to place the oscillator frequency at the correct point on the slope of the sideband filter. This is done by monitoring the signal from the filter and adjusting the proper trimmer for natural sound of voice modulation.

Modulator Alignment—The alignment is accomplished with the aid of a vacuum-tube voltmeter having an r-f probe. The probe is placed at the input terminal of the sideband filter, and the differential capacitor (C_1) in the 7360 circuit is set for balanced capacitance. The *balance* potentiometer (R_2) is set near the center of its range. With the *carrier-injection* potentiometer (R_3) turned on and advanced, a small reading will be evident on the v.t.v.m. The slug of the balanced modulator coil (L_1) is adjusted for

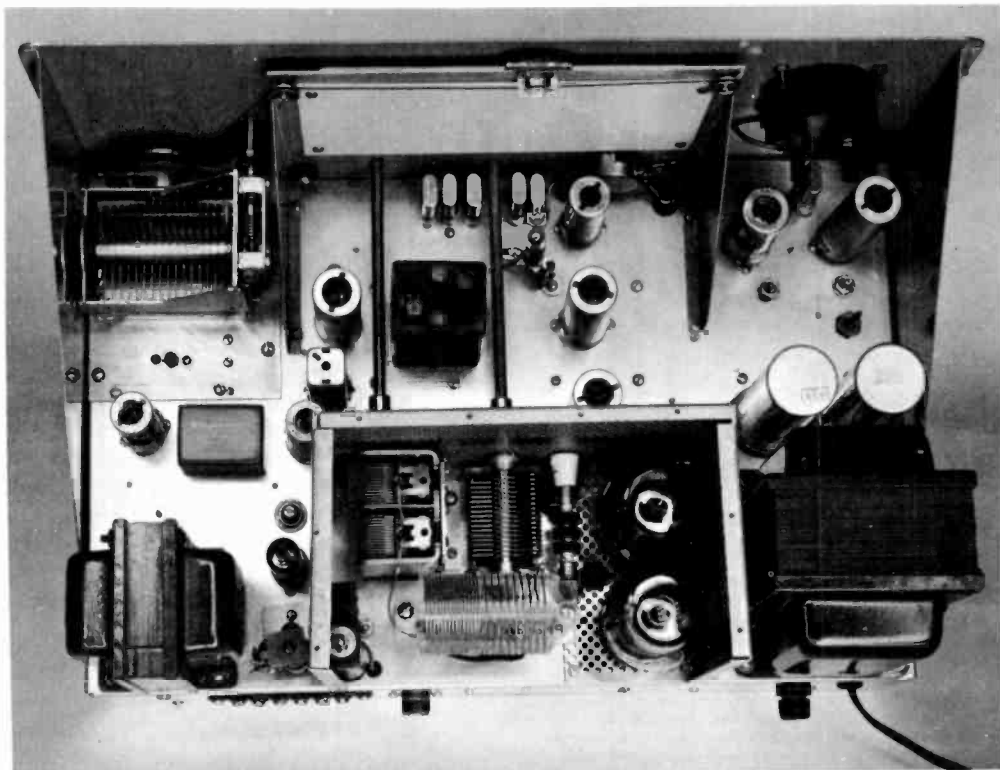

Figure 30

TOP VIEW OF SIDEBAND EXCITER CHASSIS

Layout and placement of the major above-chassis components may be seen in this photograph. The vfo tuning capacitor is mounted at the corner of the chassis with the dial drive cord passing over idler pulleys placed on the back corners of the dial assembly. Directly behind the dial assembly are the conversion oscillator and associated crystals. The two tubes located below the panel meter are the balanced modulator (right) and the speech amplifier, with the two sideband-selector crystals next to the front panel. Between these components and the high-voltage filter capacitors are located the screwdriver adjustment of the chassis-mounted modulator balance controls and the slug adjustment of the balanced modulator plate coil (L₁). The two 12BY7A tubes are in line with the 6C4 crystal oscillator, just in front of the final amplifier inclosure.

Between the two extension shafts for the final amplifier pi-network capacitors is the 80-meter bandpass transformer, with the 6BA7 mixer tube to the left. The 6AU6 vfo tube is behind the ARC-5 type tuning capacitor, next to the crystal filter, with the 6BA6 i-f amplifier tube and transformer to the right. The OA2 voltage-regulator tube is adjacent to the high-voltage filter choke, with the bias control potentiometer (R₂) next to it.

maximum reading. The probe is next moved to the #2 grid (pin 7) of the 6BA7 mixer (V_x). Function switch S₇ is placed in the zero position to close the cathode circuit of the 6BA6 amplifier stage and the slugs of transformer T₁ are tuned to achieve a maximum indicated signal level of 6 to 10 volts. To adjust carrier suppression, the carrier switch (S₂) is turned off (the v.t.v.m.

reading should drop considerably) and the carrier null potentiometer (R₂) is adjusted for minimum meter reading. Differential capacitor C₁ will affect the suppression, and these two controls should be adjusted alternately for the minimum possible meter reading.

Bandpass Transformer Alignment—Bandpass transformer T₂ is aligned with the band-

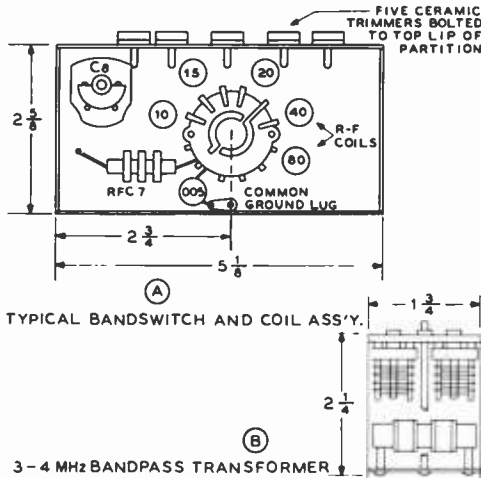

Figure 31

A—Bandswitch and coil assembly. Two assemblies are required. The partition is made of light sheet aluminum with $\frac{1}{4}$ " lips bent on all sides to mount it to the chassis and side supports. The rotor of capacitor C_1 is insulated from ground and joined to the similar capacitor on the opposite partition with an insulated coupler. The rotor is grounded to a common ground (ground lug at the bottom of the partition, below the bandswitch). The switch segment is mounted with 4-40 bolts and metal spacers to the partition with a similar size section of copper-clad phenolic circuit board spaced $\frac{1}{2}$ " behind it. The ground connections of the various coils are returned to this board, which is grounded to the common ground lug by a short flexible lead.

B—Bandpass transformer assembly. The two MAPC 35-pf capacitors are mounted on a phenolic board $1\frac{1}{4}$ " x $1\frac{1}{2}$ ". The double coil is wound on two $\frac{1}{2}$ " diameter lengths of polystyrene tubing slipped over a $\frac{3}{8}$ " diameter polystyrene rod. Each section of tubing is $\frac{1}{2}$ " long, and the spacing between the coils is $\frac{1}{8}$ ". The primary winding (plate) is 55 turns, #30 enam., bank-wound over $\frac{1}{4}$ " length. The secondary winding (grid) is 45 turns, #30 enam., wound in similar fashion. A piece of phenolic board the same size as the top mounting board supports the coils by means of 4-40 bolts and spacers. Two long 6-32 bolts join the sections and secure them to the shield can. The construction is similar to that of an air-tuned i-f transformer. Adjustment of the bandwidth is made by varying the spacing between the two windings.

switch placed in the 80-meter position and with the r-f probe placed at the plate (pin 9) of the 6BA7 mixer tube (V_2). The exciter vfo is adjusted for a carrier frequency of 3.5 MHz (vfo frequency of 5.5 MHz) and carrier is inserted to obtain a meter reading. The primary capacitor (C_1)

of the transformer is adjusted for maximum meter reading. The probe is now moved to the grid (pin 2) of the 12BY7A amplifier/mixer (V_3) and the transmitter vfo is adjusted for a carrier frequency of 4.0 MHz (vfo frequency of 5.0 MHz). With carrier injection, the secondary capacitor (C_2) of the transformer is tuned for maximum meter reading. When the dial is tuned across the 80-meter band the voltmeter reading should remain relatively constant, indicating proper alignment of the bandpass circuit.

Amplifier Alignment—The plate circuit of the 12BY7A amplifier/mixer is untuned for 80-meter operation and the remaining alignment on this band is accomplished with the r-f probe placed on the grid (pin 5) of one 6550 socket. Plate and screen voltages are removed from the 6550's. The vfo is set for a carrier frequency of 4.0 MHz and the ganged capacitors ($C_{R(A-B)}$) are set near minimum capacitance. The padding capacitor across 80-meter coil L_{15} in the 12BY7A driver stage is adjusted for maximum meter reading, with the r-f level potentiometer (R_1) advanced about quarter rotation from the minimum voltage position.

The multiple-tuned circuits in the 12BY7A stage for the higher-frequency bands are aligned with the probe positioned at the grid of one of the final amplifier tubes. With the bandswitch in the 40-meter position and the vfo adjusted for carrier output at 7.5 MHz, the ganged capacitors are set at near-minimum capacitance. The 40-meter padding capacitors across coils L_{11} and L_{16} are adjusted for maximum meter reading. It is advisable to double-check frequency with a grid-dip meter to ensure that the circuits are resonant at the desired frequency. The conversion oscillator operates on the high-frequency side of each amateur band and it is possible to inadvertently tune the driver circuits to the crystal frequency instead of the sideband frequency during the initial alignment procedure. A check with the grid-dip meter will disclose this error. As tuning is done with inserted carrier, removing the carrier should cause the v.t.v.m. reading to drop to practically zero. If this is not the case, the circuits may be erroneously tuned to the crystal frequency.

The multiple tuned circuits may now be adjusted on each higher-frequency band,

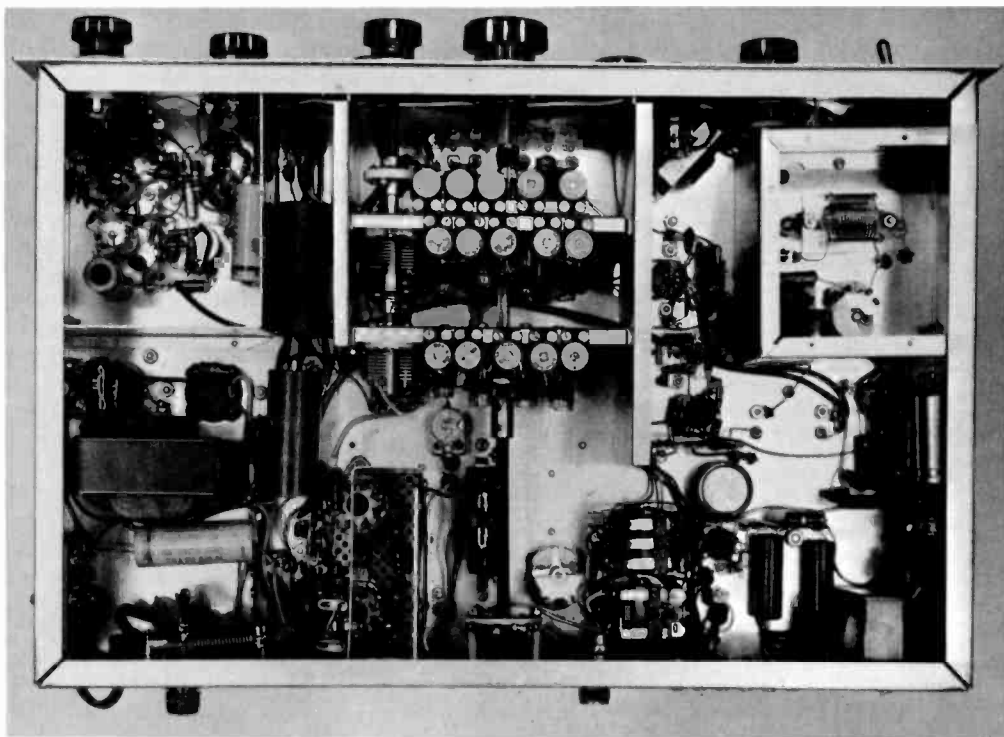

Figure 32

UNDER-CHASSIS VIEW OF SSB EXCITER

The bandswitch catacomb occupies the front-center of the under-chassis area. The bandswitch assembly is fastened to the front apron of the chassis with the switch segments mounted on the shield partitions as shown in figure 31.13 Two sideplates complete the assembly. The final amplifier pi-network switch segment is mounted on the rear apron of the chassis and is driven by a phenolic extension shaft and metal coupling. The balanced modulator and speech amplifier components are placed in an L-shaped shield at the left front of the chassis area. Connection between the modulator plate tank circuit and the sideband filter (right of chassis) is made via a length of RG-174/U coaxial cable, seen as a black line running across the chassis. The bottom plate of the vfo compartment has been removed to show the placement of the oscillator coil and padding capacitor, which may be adjusted from the top of the chassis.

The silicon-diode rectifiers in the power supply are mounted on a phenolic board placed on the left apron of the chassis, near the rear corner. The final amplifier tube sockets are mounted on a small rectangle of perforated aluminum to provide ample ventilation, with a UP-shaped shield seen on-edge around the plate pins and parasitic chokes. To the right of the final amplifier bandswitch segment are the two control relays, with the 80-meter amplifier padding capacitor between the relays and the bandswitch. The bias transformer and filter capacitors are at the rear of the chassis to the right of the relays.

with the ganged capacitors set at minimum and alignment of the padding capacitors done at the high-frequency end of each band.

Final Amplifier Adjustment—Before applying screen or plate voltage to the final amplifier, it must be neutralized. The r-f probe is placed at the plate pin of one 6550

tube and carrier is inserted. Neutralization is best done on the 20-meter range, with driver circuits resonated to provide maximum grid drive to the amplifier stage. The loading capacitor (C_{15}) is set to maximum capacitance and the tuning capacitor (C_{14}) is adjusted for maximum indicated voltage (resonance). Neutralizing capacitor C_{12} is

L ₁ , L ₂	Balanced modulator coil. 12 bifilar turns (24 in all) No. 24 e. 1/2" dia., 1 1/6" long on National XR-50 form. Link: 4 turns No. 24 e around center of L ₁ .
L ₃	5.0-5.5 MHz vfo coil. 12 turns No. 20, 3/4" dia., 7/8" long. (Air-Dux 616T.)
L ₄ , L ₅	Low-pass filter. Each: 28 turns No. 26 closewound on 1/4" dia. fiber rod.
L ₆	11 MHz. 26 turns No. 24 e. Closewound on 3/8" dia. polystyrene rod, 1 1/4" long
L ₇	18 MHz. 18 turns as above
L ₈	25 MHz. 12 turns as above
L ₉	32.5 MHz. 8 turns as above
L ₁₀	33.0 MHz. 7 turns as above
L ₁₅	80 meters. 60 turns No. 20 closewound on 3/8" dia. polystyrene rod.
L ₁₁ , L ₁₆	40 meters. 20 turns No. 26 as above (padded with 82 pf.)
L ₁₂ , L ₁₇	20 meters. 18 turns No. 24 as above
L ₁₃ , L ₁₈	15 meters. 9 turns No. 22 as above
L ₁₄ , L ₁₉	10 meters. 7 turns No. 20 as above
L ₂₀	Pi-network coil (Pi-Dux 1212D6) 1 1/4" dia., 9 turns 1 1/2" long and 14 turns 1 1/8" long, No. 14 wire (18.6μh). Tap from plate end: 10 meters, 2 turns 15 meters, 3 turns 20 meters, 8 turns 40 meters, 12 turns

Table 2
COIL TABLE FOR 175-WATT
SSB EXCITER

Small coils are wound on homemade coil forms cut from 3/4" diameter polystyrene rod. Forms are 1 1/4" long, with small holes drilled 1/2" apart to secure ends of windings. Bottom of coil forms are tapped for 4-40 bolts for mounting to coil partitions. Commercial 3/8" diameter forms may be substituted at considerable increase in cost.

adjusted for minimum voltage reading on the meter, with the tuning capacitor re-adjusted after each change of the neutralizing capacitor.

Once the amplifier stage is neutralized and the exciter circuits properly aligned, the complete exciter may be tested with a suitable dummy load for complete operation. Final-amplifier plate loading and excitation level are both indicated on the single meter in the cathode circuit of the amplifier stage. The tune-up sequence is the same on any band: the *function switch* (S₂) is placed in the push-to-talk position, the *audio gain* control (R₁) is turned down, *sideband selector* switch S₁ is placed in the

proper position for the band in use, and *carrier-injection* switch S₂ is turned off. When the push-to-talk switch on the microphone is closed, the plate meter will indicate an idling current of about 70 ma. The carrier control is turned on and advanced slightly, and grid tuning is peaked for a rise in plate current. The plate tank capacitor is tuned for current dip and loading adjustments are made using regular pi-network procedure. Maximum loaded plate current with full carrier insertion is 200 to 240 ma and this value is reached by advancing the carrier control, together with an increase in amplifier loading. When the inserted carrier is removed, the plate current will drop back to the original idling level.

The final step is to determine the ratio of grid drive to plate current loading. If this ratio is improperly set, the exciter will "flat-top" before full output level is reached (excessive-drive, light-loading condition), or transmitter output will be low (insufficient-drive, heavy-loading condition). Excitation is set by means of the *r-f level* control (R₁) which may be calibrated for each band. To do this, it is necessary to place a 0 to 1 d-c milliammeter between test points 2 and 3 in the grid circuit of the final amplifier stage. No grid current will be drawn until the peak of the r-f driving signal exceeds the bias level (a nominal -36 volts). Maximum power output will be obtained in class-AB₁ Service when the amplifier tubes are driven just to the point of grid current and with plate loading then adjusted for maximum power output at a plate current of 200 to 240 ma. Using carrier insertion, then, the point of grid current is monitored on the temporary test meter and plate loading is adjusted for the proper plate current. The setting of the r-f level control is logged and carrier is removed and the transmitter modulated by voice. The audio gain control is advanced until, with the r-f level control untouched, the grid-circuit test meter just indicates a flicker of grid current: one scale division or less. The setting of the audio gain control is then logged. This calibration procedure should be run on each amateur band and the settings of the controls noted for future use. If desired, a small 1-inch diameter milliammeter may be panel mounted on the unit

for a continual check of the amplifier peak signal driving point. It should be noted that under maximum peak voice conditions, the plate meter will swing to about 100 ma. Operation may be monitored with an oscilloscope to check "flat-topping."

The tune-up procedure for c.w. is the same as above except that carrier is inserted and the audio gain control turned down. A-m operation is possible by inserting sufficient carrier for a plate current of about 100 ma and advancing the gain control while monitoring the ratio of grid drive to antenna loading with an oscilloscope to achieve maximum modulation level without distortion.

27-7 Audio Filters For SSB and C-W Reception

Customized audio filters can greatly improve reception on all but the most expensive amateur receivers that incorporate switchable i-f filters. Even in the case of the more sophisticated receiver, a good audio filter can remove a large amount of back-

ground noise, high-frequency hiss and objectionable sideband "monkey chatter." It is surprising how much objectionable interference can pass through the skirts of a good i-f filter system. The cumulative effect of such interference is operator fatigue over extended periods of reception.

Two audio filters are shown herewith that work wonders for serious DX reception of SSB or c.w. The SSB filter, to be described first, is a low-pass configuration, designed to reject all audio frequencies above 3000 Hz. Cutoff is quite sharp, and filter rejection is better than 40 decibels at all frequencies above about 3700 Hz. The c-w filter is designed for a spot frequency of 810 Hz and has a passband of 1100 Hz at a reference level 30 decibels below the signal level at the design frequency. The nose of the passband is 90 Hz wide at the -3 decibel reference points. Both filters are made up of inexpensive 88-mH, high-Q toroid coils that have been advertised in amateur magazines for years. Each toroid has two coils on it, and they must be connected in series to provide a total inductance of 88 mH.

The SSB Audio Filter The SSB filter is designed for improved voice reception and should be placed between the receiver and a pair of low-impedance earphones. Image-parameter design was used to determine the theoretical constants of the filter, which were then altered slightly to fit the available components at hand. The layout of the filter is shown in figure 33 and the schematic and passband are shown in figure 34.

Inexpensive 6-volt filament transformers are used to terminate the filter, as 500 ohm/4 ohm audio transformers are expensive and hard to obtain. The filter is built on a section of punched circuit board and may be mounted in the speaker cabinet of the receiver and left permanently in the circuit. Only two values of capacitors need be purchased: .02 μfd and .047 μfd Mylar capacitors should be used, if possible, although paper ones will also serve. If it is possible to check a handful of capacitors on a bridge before purchase, the target values shown in the schematic should be picked out, however, reliance upon random capacitor values will not degrade filter response too greatly.

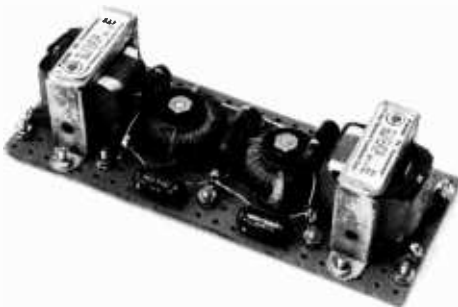

Figure 33

LOW-PASS AUDIO FILTER FOR IMPROVED SSB RECEPTION

Two six-volt filament transformers, two 88-mH inductors and a handful of mylar capacitors make efficient filter assembly for improved SSB reception. Filter cuts out interference and "monkey chatter" above 3000 Hz. Unit is designed to be placed in low-impedance line to speaker or earphones.

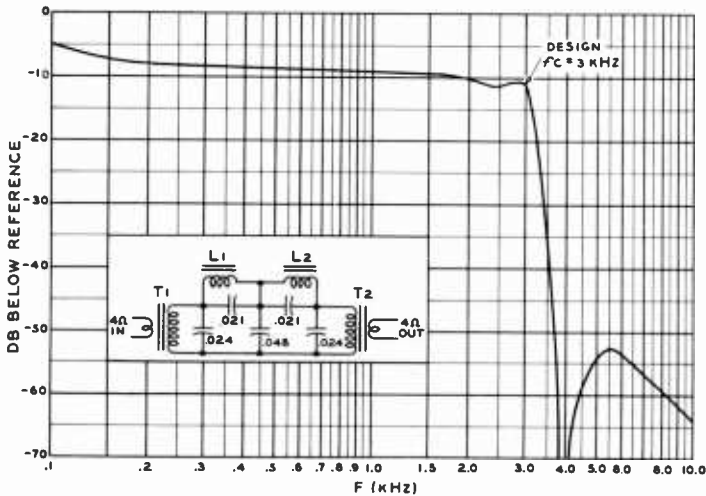

Figure 34
PASSBAND OF SSB FILTER

Since the field of the toroidal coils is entirely self-contained, the coils may be mounted to the board with brass hardware. Other components are conveniently grouped around the coils, as shown in the photograph.

Insertion loss of the filter is about 10 decibels, but this will not usually be objectionable, as most receivers have an abundance of audio gain. Once in use, the rejection of high-frequency chatter in SSB

reception will be immediately noticeable, and the improved smoothness of received signals will do much to reduce operator fatigue.

The C-W Audio Filter The c-w filter is built up in the same fashion as the SSB filter. This filter, however is designed for low-impedance input and high-impedance output. A pair of high-impedance

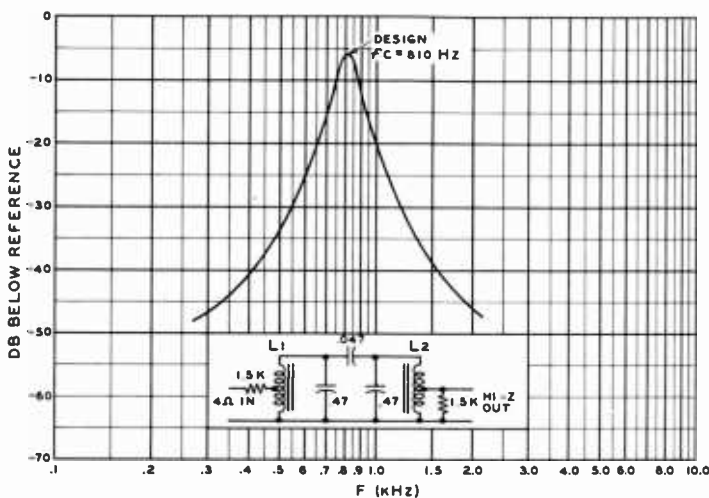

Figure 35
PASSBAND OF C-W FILTER

crystal earphones are recommended, or the filter may be run into a small auxiliary amplifier for low-impedance earphones. Filter loss may be made up by increasing the gain level of the receiver.

The toroidal coils serve as tuned circuits and step-up transformers, providing two high-Q circuits resonating at 810 Hz (figure 35). The two .47- μ f capacitors should be matched on a bridge to provide optimum passband. The resonant frequency of the filter may be moved higher or lower in frequency, if desired, by altering the value of the shunt capacitors.

As the nose of the passband is only about 90 Hz wide, careful tuning of the station receiver is important for best results. The receiver should be set for c-w reception with the narrowest passband possible. The filter is cut in and the bfo of the receiver is slowly varied for maximum noise output from the filter. C-w signals are now tuned in and the bfo slowly and carefully adjusted to provide the most pleasing response. Receiver tuning should be slow, since it is easy to miss signals under such selective receiving conditions. Audio level should be held low to reduce possible "ringing" of the filter.

H-F and VHF Power Amplifiers

A *power amplifier* is a converter that changes d-c into r-f output. Chapter Seven of this Handbook discussed the various classes of r-f power amplifiers and Chapters Eleven and Twelve covered the calculation of input and output circuit parameters. This chapter covers power-amplifier design, construction, and adjustment.

Modern h-f amateur transmitters are capable of operating on c-w, SSB and often RTTY, on one or more amateur bands between 3.5 MHz and 29.7 MHz. Very few pieces of commercially built amateur equipment have amplitude-modulation capability, other than some gear designed for 6- and 2-meter operation, since the changeover from a.m. to SSB during the past decade is now almost complete. On the other hand, expansion of 160-meter privileges in the past years has not brought about the inclusion of that band in most amateur equipment.

The most popular and flexible amateur h-f transmitting arrangement usually includes a compact bandswitching exciter or transceiver having 100 to 500 watts PEP input on the most commonly used h-f bands, followed by a single linear power-amplifier stage having 1 kW to 2 kW PEP input capacity. In many instances, the exciter is an SSB transceiver unit capable of mobile operation, while the amplifier may be a compact tabletop assembly. The amplifier is usually coupled to the exciter by a coaxial cable and changeover relay combination, permitting

the exciter to run independently of the amplifier, if desired, or in combination with the amplifier for maximum power output. For c.w. or RTTY, the amplifier is usually operated in the linear mode, since conversion to class-C operation is not required.

These practical designs are a natural outgrowth of the importance of vfo operation and the use of SSB and c-w modes in amateur practice. It is not practical to make a rapid frequency change when a whole succession of stages must be retuned to resonance, or when bandswitching is not employed. Another significant feature in station design is the popularity of 100- to 250-watt output SSB exciter/transceivers. These provide sufficient drive for high-level linear amplifiers without the need for intermediate stages of amplification.

Power-Amplifier Design Power amplifiers are classified according to operating mode and circuitry. Thus,

a particular amplifier mode may be class AB₁, class B, or class C; the circuitry can be either single-ended or push-pull; and the unit may be grid- or cathode-driven. Mode of operation and circuit configuration should not be confused, since they may be mixed in various combinations, according to the desire of the user and the characteristics of the amplifier tube.

High-frequency silicon power transistors are used in some advanced amateur and

commercial equipment designs up to the 100-watt PEP power level or so. More general use of solid-state devices in amateur power-amplifier equipment is inhibited because of the relatively high cost of suitable devices and the problem of achieving good linearity in solid-state amplifier circuitry. Undoubtedly solid-state devices will become of increasing importance in h-f power amplifiers in the coming decade, as these problems become solved in an economic manner.

Either triode or tetrode tubes may be used in the proper circuitry in h-f and vhf power amplifiers. The choice of tube type is often dependent on the amount of drive power available and, in the case of home-made gear, the tube at hand. If an exciter of 100 to 200 watts PEP output capacity is to be used, it is prudent to employ an amplifier whose drive requirement falls in the same power range as the exciter output. Triode or tetrode tubes may be used in cathode-driven (grounded-grid) circuitry which will pass along an excess of exciter power in the form of feedthrough power to the antenna circuit. The tubes may also be grid-driven in combination with a power absorption network that will dissipate excess exciter power not required by the amplifier.

On the other hand, if the power output of the exciter is only a few watts PEP, either low-drive, high-gain tetrodes must be used in grid-driven configuration, or an intermediate amplifier must be used to boost the drive to that level required by triode tubes. Thus, the interface between the exciter and the amplifier in terms of PEP level must be reconciled in the design of the station transmitting equipment.

28-1 Triode Amplifier Design

Triode tubes may be operated in either grid- or cathode-driven configuration, and may be run in class-AB₁, class-AB₂, class-B or class-C mode. Plate dissipation and amplification factor (μ) are two triode characteristics which provide the information necessary to establish proper mode and circuitry and to evaluate the tube for linear-amplifier or class-C service.

Plate dissipation is important in that it determines the ultimate average and peak

power capabilities of the tube. Linear amplifiers commonly run between 55- and 65-percent plate efficiency, with the majority of the remainder of the power being lost as plate dissipation. Class-C service often runs at about 70- to 75-percent plate efficiency. Knowing the plate dissipation rating of the tube, the approximate maximum power input and output levels for various modes of service may be determined by the methods outlined in Chapter 7.

Amplification Factor (μ) of a triode expresses the ratio of change of plate voltage for a given change in grid voltage at some fixed value of plate current. Values of μ between 10 and 300 are common for triode transmitting tubes. High- μ tubes (μ greater than about 30) are most suitable in cathode-driven (grounded-grid) circuitry as the cathode-plate shielding of a high- μ tube is superior to that of a comparable low- μ tube, and because a high- μ tube provides more gain and requires less driving power than a low- μ tube in this class of service. Low- μ triodes, on the other hand, are well suited for grid-driven class-AB₁ operation since it is possible to reach a high value of plate current with this type of tube, as opposed to the high- μ equivalent, without driving the grid into the power-consuming, positive region. Even though a large value of driving voltage is required for the low- μ tube, little drive power is required for class-AB₁ service, since the grid always remains negative and never draws current.

As a rule-of-thumb, then, a triode tube to be used for linear r-f service in a power amplifier should have a large plate-dissipation capability, and the output power to be expected from a single tube will run about twice the plate-dissipation rating. High- μ triodes, generally speaking, perform better in cathode-driven, class-B circuitry; whereas medium- and low- μ triodes are to be preferred in grid-driven, class AB₁ circuitry. Circuit neutralization may often be disposed with in the first case (at least in the h-f region), and is always necessary in the second case, otherwise the circuits bear a striking similarity.

Grid-Driven Circuitry Representative grid- and cathode-driven triode circuits are shown in figure 1. The classic

TRIODE CIRCUITRY

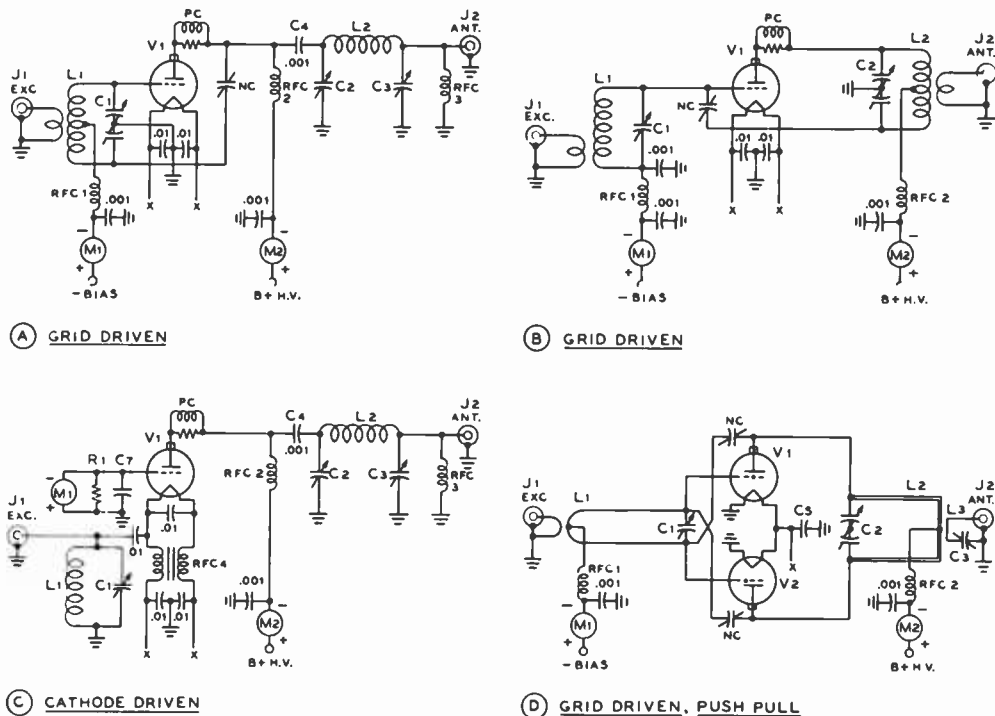

Figure 1

REPRESENTATIVE TRIODE AMPLIFIER CIRCUITS

Circuits A, B and C are for the 3-54 MHz region. Circuit D is intended for the 50-500 MHz region. Note that one filament leg is grounded in circuit D to reduce inductance of filament return circuit.

- C₁—Input tuning capacitor. Typically, 3 pf per meter of wavelength. Spacing 0.03" for power level up to 2 kW, PEP
- C₂—Output tuning capacitor. Refer to plate-circuit design data in Chapter 11.
- C₃—Loading capacitor. Typically, 20 pf per meter of wavelength. Refer to Chapter 11.
- C₄—Plate-blocking capacitor. Typically, 500 pf to 1000 pf, 5 kV
- C₅, C₆—Low-inductance mica or ceramic capacitor, series resonant near operating frequency. See Chapter 17
- M₁—Grid-current meter
- M₂—Plate-current meter
- RFC₁—Grid choke, receiving type rated to carry

- grid current. Typically, 1 to 2.5 mA for 3 to 30-MHz range
- RFC₂—Plate choke, transmitting type, solenoid. Rated to carry plate current. Typically, 800 μH. See Chapter 17
- RFC₃—Receiving-type choke. 2½ mH for 3- to 30-MHz range.
- RFC₄—Bifilar windings, 15 turns each #12 wire on ½-inch diameter ferrite core, 3" long for 3- to 54-MHz range
- PC—Plate parasitic suppressor. Typically, 3 turns #18 enamel, ½-inch diameter, ½-inch long, in parallel with 50-ohm 2-watt composition resistor. See Chapter 17

grid-driven, grid-neutralized circuit is shown in illustration A. The drive signal is applied to a balanced grid tank circuit (L₁, C₁) with an out-of-phase portion of the exciting voltage fed through capacitor NC to the plate circuit in a bridge neutralization scheme. A pi network is employed for the plate output coupling circuit. The plate inductor (L₂) may be tapped or otherwise var-

iable and is normally adjustable from the amplifier panel, eliminating the necessity of plug-in coils and access openings into the shielded amplifier inclosure. The grid circuit may also be switched or varied in a similar manner.

Neutralization may be accomplished in the plate circuit, as shown in figure 1B. A split plate-tank circuit is required in place

of the split grid circuit, making the use of a single-ended pi-network output circuit impractical. Theory and adjustment of grid and plate neutralizing circuits are covered in Chapter 11. In either configuration, care must be taken in construction to make sure that a minimum of stray coupling exists between grid and plate tank circuits. Whenever possible, the grid and plate coils should be mounted at right angles to each other, and should be separated sufficiently to reduce coupling between them to a minimum. Unwanted coupling will tend to make neutralization frequency-sensitive, requiring that the circuit be reneutralized when a major frequency change is made.

Cathode-Driven Circuitry A representative cathode-driven (grounded-grid) triode circuit is shown in figure 1C. A pi-network plate circuit is used, and excitation is applied to the filament (cathode) circuit, the grid being at r-f ground potential. If the amplification factor of the triode is sufficiently high so as to limit the static plate current to a reasonable value, no auxiliary grid bias is required. A parallel-tuned cathode input circuit is shown, although pi-network circuitry may be used in this position. Filament voltage may either be fed via a shunt r-f choke as shown, or applied through a bifilar series-fed cathode tank coil.

While nominally at r-f ground, the grid of the triode may be lifted above ground a sufficient amount so as to insert a monitoring circuit to measure d-c grid current. The grid to ground r-f impedance should remain very low, and proper attention must be paid to the r-f circuit. A considerable amount of r-f current flows through the grid bypass capacitor (C_7) and this component should be rated for r-f service. It should be shunted with a low value of resistance (of the order of 10 ohms or less) and the d-c voltage drop across this resistor is monitored by the grid voltmeter, which is calibrated in terms of grid current. Both resistor and capacitor aid in establishing a low-impedance path from grid to ground and should be mounted directly at the socket of the tube. If multiple grid pins are available, each pin should be individually

bypassed to ground. Control of the grid-to-ground impedance in the cathode-driven circuit establishes the degree of intrastage feedback, and an increase in grid impedance may alter stage gain, leading to possible uncontrolled oscillation or perhaps making the stage difficult to drive. At the higher frequencies, stage gain may be controlled by the proper choice of the grid-to-ground impedance.

Push-Pull Circuitry A push-pull triode amplifier configuration is shown in figure 1D. This circuit design is now rarely used in the h-f region because of the mechanical difficulties that ensue when a large frequency change is desired. In the vhf region, on the other hand, where operation of an amplifier is generally restricted to one band of frequencies, linear push-pull tank circuits are often employed. Lumped-inductance tank coils are usually avoided in the vhf region since various forms of parallel-line or strip-line circuitry provide better efficiency, higher Q and better thermal stability than the coil-and-capacitor combination tank assemblies used at the high frequencies. Push-pull operation is of benefit in the vhf region as unavoidable tube capacitances are halved, and circuit impedances are generally higher than in the case of single-ended circuitry. At the higher vhf regions, parallel- and strip-line circuitry give way to coaxial tank circuits in which the tube structure becomes a part of the resonant circuit.

The output coupling circuit may be designed for either balanced or unbalanced connection to coaxial or twin-conductor transmission line. In many cases, a series capacitor (C_3) is placed in one leg of the line at the feed point to compensate for the inductance of the coupling coil.

Common h-f construction technique employs plug-in plate and grid coils which necessitate an opening in the amplifier enclosure for coil-changing purposes. Care must be taken in the construction of the door of the opening to reduce harmonic leakage to a minimum. While variations in layout, construction, and voltage application are found, the following general remarks apply to h-f amplifiers of all classes and types.

Circuit Layout The most important consideration in constructing a push-pull amplifier is to maintain electrical symmetry on both sides of the balanced circuit. Of utmost importance in maintaining electrical balance is the control of stray capacitance between each side of the circuit and ground.

Large masses of metal placed near one side of the grid or plate circuits can cause serious unbalance, especially at the higher frequencies, where the tank capacitance between one side of the tuned circuit and ground is often quite small in itself. Capacitive unbalance most often occurs when a plate or grid coil is located with one of its ends close to a metal panel. The solution to this difficulty is to mount the coil parallel to the panel to make the capacitance to ground equal from each end of the coil, or to place a grounded piece of metal opposite the "free" end of the coil to accomplish a capacity balance.

All r-f leads should be made as short and direct as possible. The leads from the tube grids or plates should be connected directly to their respective tank capacitors, and the leads between the tank capacitors and coils should be as heavy as the wire that is used in the coils themselves. Plate and grid leads to the tubes may be made of flexible tinned braid or flat copper strip. Neutralizing leads should run directly to the tube grids and plates and should be separate from the grid and plate leads to the tank circuits. Having a portion of the plate or grid connections to their tank circuits serve as part of a neutralizing lead can often result in amplifier instability at certain operating frequencies.

Filament Supply The amplifier filament transformer should be placed right on the amplifier chassis in close proximity to the tubes. Short filament leads are necessary to prevent excessive voltage drop in the connecting leads, and also to prevent r-f pickup in the filament circuit. Long filament leads can often induce instability in an otherwise stable amplifier circuit, especially if the leads are exposed to the radiated field of the plate circuit of the amplifier stage. The filament voltage should be the correct

value specified by the tube manufacturer when measured *at the tube sockets*. A filament transformer having a tapped primary often will be found useful in adjusting the filament voltage. When there is a choice of having the filament voltage slightly higher or slightly lower than normal, the lower voltage is preferable.

Filament bypass capacitors should be low internal inductance units of approximately $.01 \mu\text{fd}$. A separate capacitor should be used for each socket terminal. Lower values of capacitance should be avoided to prevent spurious resonances in the internal filament structure of the tube. Use heavy, shielded filament leads for low voltage drop and maximum circuit isolation.

Plate Feed The series plate-voltage feed shown in figure 1D is the most satisfactory method for push-pull stages. This method of feed puts high voltage on the plate tank inductor, but since the r-f voltage on the inductor is in itself sufficient reason for protecting the inductor from accidental bodily contact, no additional protective arrangements are made necessary by the use of series feed.

The insulation in the plate supply circuit should be adequate for the voltages encountered. In general, the insulation should be rated to withstand at least four times the maximum d-c plate voltage. For safety, the plate meter should be placed in the cathode return lead, since there is danger of voltage breakdown between a metal panel and the meter movement at plate voltages much higher than one thousand.

Parallel plate feed, such as shown in figures 1A and 1B, is commonly used for single-ended pi-network amplifier configurations. The plate r-f choke is a critical component in this circuit, and a discussion of choke design is covered in Chapter 17. The plate-blocking capacitor (C_4) should be rated to withstand the peak r-f plate current (usually about three to four times the d-c plate current) and the peak r-f voltage (up to twice the d-c plate voltage.)

In the case of the push-pull stage, the amplifier grid and plate circuits should be symmetrically balanced to ground. In some instances, a small differential capacitor is

placed in the grid circuit to effect balance, and the grid current of each tube is monitored individually to ascertain correct balance. The rotor of the split-stator plate-tuning capacitor is usually ungrounded, permitting the plate tank circuit to establish its own r-f balance.

The various filament, grid, and plate bypass capacitors are often vhf coaxial types which have inherently low inductance well into the vhf region. These capacitors should be checked to make sure that their internal self-resonant frequency is well above the operating frequency of the amplifier.

In most cases, the push-pull amplifier may be cross-neutralized in the normal manner. At the higher frequencies (above 150 MHz or so) it is common practice to operate the triode tubes in cathode-driven configuration

which usually eliminates the need for neutralization if proper shielding is used.

Plate parasitic suppressors may or may not be necessary depending on the operating frequency of the amplifier and the natural parasitic frequency of the input and output circuits. Both grid- and plate-tuning capacitors should be located close to the tube elements and not tapped down the tuned lines, otherwise unwanted parasitic circuits may be created. If oscillations are encountered, they may possibly be suppressed by placing noninductive carbon resistors across a portion of the plate (and grid) lines as shown in figure 2.

The plate choke (RFC) should be mounted at right angles to the plate line and care should be taken that it is not coupled to the line. In particular, the choke should not be mounted within the line, but rather outside the end of the line, as shown. A resistor (R_1) is used to take the place of a grid choke, thus eliminating any possibility of resonance between the two chokes, with resulting circuit instability.

In order to prevent radiation loss from the grid and plate lines, it is common practice to completely inclose the input and output circuits in "r-f tight" inclosures, suitably ventilated to allow proper cooling of the tubes.

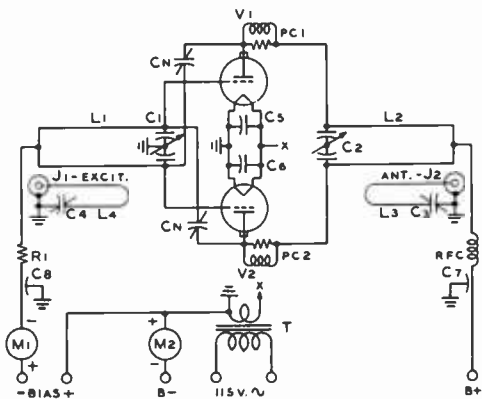

Figure 2

TYPICAL PUSH-PULL VHF TRIODE AMPLIFIER CIRCUIT

- C_1, C_2 —Low-capacitance, balanced split-stator capacitor. Typically, 10 pf per section for 144 MHz.
- C_5, C_6 —Loading capacitor. Capacitance chosen to series resonate at operating frequency with coupling loop
- C_3, C_4 —Low inductance mica or ceramic capacitor, series resonant near operating frequency. See Chapter 17
- C_7 —Low-inductance feedthrough capacitor. See Chapter 17
- C_N —Neutralizing capacitor. Approximately equal to grid-plate capacitance of triode tube
- M_1 —Grid-current meter
- M_2 —Plate-current meter
- R_1 —Wire resistor (100–500 ohms) to act as low-Q r-f choke
- RFC—Vhf choke rated to carry plate current. See text

28-2 Tetrode Amplifier Design

As in the case of triode tubes, tetrodes may be operated in either grid- or cathode-driven configuration and may (within certain limits) be run in class- AB_1 , - AB_2 , -B, or class-C mode. Much of the information on circuit layout and operation previously discussed for triode tubes applies in equal context to tetrodes. Other differences and additional operational data will be discussed in this section.

Tetrode tubes are widely used in h-f and vhf amplifiers because of their high power gain and wide range of simple neutralization. Tetrode circuitry resembles triode circuitry in that comparable modes and circuit configurations may be used. Various popular and proven tetrode circuits are shown in figure 3. Illustration A shows a typical single-ended neutralized tetrode circuit em-

TETRODE CIRCUITRY

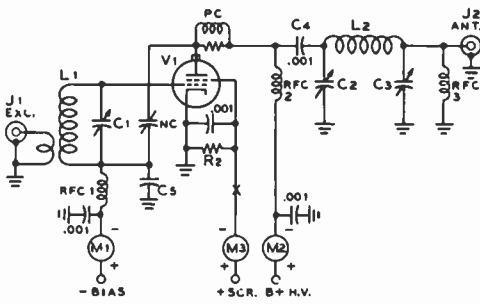

(A) GRID DRIVEN

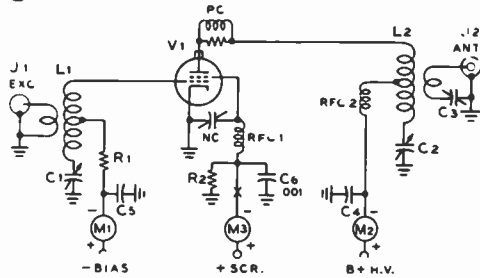

(B) GRID DRIVEN

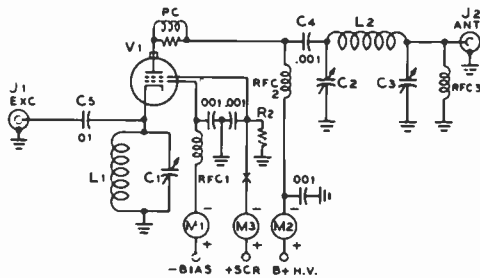

(C) CATHODE DRIVEN

Figure 3

REPRESENTATIVE TETRODE AMPLIFIER CIRCUITS

Circuit B is intended for operation above the self-neutralizing frequency of the tetrode. Above 30 MHz or so, the screen bypass capacitor of circuits A and C is often chosen so as to be self-resonant at the operating frequency of the amplifier.

- C₁, L₁—Input tuned circuit. Typically, 3 pf per meter of wavelength for circuits A and B. 20 pf per meter of wavelength for circuit C
- C₂, C₃, L₂—Pi-network plate circuit. Refer to plate-circuit design data in Chapter 11
- C₄—Plate-blocking capacitor. Typically, 500 pf to 1000 pf at 5 kV
- R₁—Wirewound resistor (100-500 ohms) to act as low-Q r-f choke
- R₂—Screen resistor to carry negative screen

current and complete screen-to-ground circuit. See tube data sheet for details

PC—Plate parasitic suppressor. See Chapter 17 and figure 1 of this chapter. For vhf operation, suppressor may consist of composition resistor shunted across a short portion of the plate lead

RFC₁—Grid choke, receiving type. Typically, 2.5 mH for 3- to 30-MHz range. Vhf-rated choke for 50 MHz and 144 MHz

RFC₂—Plate choke, transmitting type, solenoid. Rated to carry plate current. Typically, 800 μH for 3- to 30-MHz range. Vhf-rated choke for 50 MHz and 144 MHz.

RFC₃—Receiving-type choke. 2.5 mH for 3- to 30-MHz range

M₁—Grid-current meter

M₂—Plate-current meter

M₃—Screen-current meter

employing a pi-network output circuit and a bridge neutralization scheme. Tetrode neutralization techniques are discussed in detail in Chapter 11.

Tetrode plate current is a direct function of screen voltage and means must be employed to control screen voltage under all conditions of operation of the tetrode. In particular, if the d-c screen-to-ground path is broken, the screen voltage may rise to equal the plate potential, thus damaging the tube and rupturing the screen bypass capacitor. It is dangerous, therefore, to reduce screen voltage for tuneup purposes by simply breaking the screen power lead unless a protective screen bleeder resistor (R₂) is placed directly at the tube socket, as shown in the illustrations of figure 3. If this resistor is used, the screen supply may be safely broken at point X for tuneup purposes, or for reduced-power operation. The value of screen bleeder resistance will vary depending on tube characteristics, and a typical value is generally specified in the tube data sheet. For tubes of the 4CX250B family, the value of resistance is chosen to draw about 15 to 20 ma from the screen power supply. The 4CX1000A, on the other hand, requires a screen bleeder current of about 70 ma.

In any case, regardless of whether the screen circuit is broken or not, the use of a screen bleeder resistor in the circuit at all times is mandatory for those tetrodes which produce reverse screen current under certain operating conditions. This is a normal characteristic of most modern, high-gain tetrodes and the screen power supply should be designed with this characteristic in mind so that correct operating voltages will be maintained on the screen at all times.

With the use of a screen bleeder resistor, full protection for the screen may be provided by an overcurrent relay and by interlocking the screen supply so that the plate voltage must be applied before screen voltage can be applied.

Power output from a tetrode is very sensitive to screen voltage, and for linear service a well-regulated screen power supply is required. Voltage-regulator tubes or a series-regulated power supply are often used in high-power tetrode linear-amplifier stages.

A tetrode neutralizing circuit suitable for the lower portion of the vhf region is shown in figure 3B. When the operating frequency of the tetrode is higher than the self-neutralizing frequency, the r-f voltage developed in the screen circuit is too great to provide proper voltage division between the internal capacitances of the tube (see Chapter 11). One method of reducing the voltage across the screen lead inductance and thus achieving neutralization is to adjust the inductive reactance of the screen-to-ground path so as to lower the total reactance. This reactance adjustment may take the form of a variable series capacitor as shown in illustration B. This circuit is frequency sensitive and must be readjusted for major changes in the frequency of operation of the amplifier.

Balanced input and output tuned circuits are used in the configuration of figure 3B. In the grid circuit, the split capacitance is composed of variable capacitor C_1 and the grid-cathode input capacitance of the tube. The coil (L_1) is chosen so that C_1 approximates the input capacitance. The same technique is employed in the plate circuit, where a split tank is achieved by virtue of capacitance C_2 and the output capacitance of the tetrode tube.

A cathode-driven tetrode amplifier is shown in illustration C. Many tetrodes do not perform well when connected in class-B grounded-grid configuration (screen and grid both at ground potential). These tubes are characterized by high pervance, together with extremely small spacing between the grid bars, and between the grid structure and the cathode. Tubes of the 4-65A, 4X150A/4CX250B, and 4CX1000A family are in this class. For proper operation of these high-gain tubes, the screen requires

much larger voltage than the control grid. When the electrodes of these tubes are tied together, the control grid tends to draw heavy current and there is risk of damaging the tube. Lower-gain tetrodes, such as the 813, 4-400A, and 4-1000A have a more balanced ratio of grid to screen current and may be operated in zero-bias, grounded-grid mode. The best way to employ the higher-gain tetrode tubes in cathode-driven service is to ground the grid and screen through bypass capacitors and to operate the elements at their rated class AB₁ d-c voltages. In all cases, grid and screen current should be monitored so as to keep maximum currents within ratings.

Tetrode Amplifier Circuitry The most widely used tetrode circuitry for h-f use is the single-ended pi-network configuration, variations of which are shown in figure 4.

A common form of pi-network amplifier is shown in figure 4A. The *pi* circuit forms the matching system between the plate of the amplifier tube and the low-impedance, unbalanced, antenna circuit. The coil and input capacitor of the *pi* may be varied to tune the circuit over a 10 to 1 frequency range (usually 3.0 to 30 MHz). Operation over the 20- to 30-MHz range takes place when the variable slider on coil L_2 is adjusted to short this coil out of the circuit. Coil L_1 therefore comprises the tank inductance for the highest portion of the operating range. This coil has no taps or sliders and is constructed for the highest possible Q at the high-frequency end of the range. The adjustable coil (because of the variable tap and physical construction) usually has a lower Q than that of the fixed coil.

The degree of loading is controlled by capacitors C_4 and C_5 . The amount of circuit capacitance required at this point is inversely proportional to the operating frequency and to the impedance of the antenna circuit. A loading capacitor range of 100 to 2500 pf is normally ample to cover the 3.5- to 30-MHz range.

The *pi* circuit is usually shunt-fed to remove the d-c plate voltage from the coils and capacitors. The components are held at

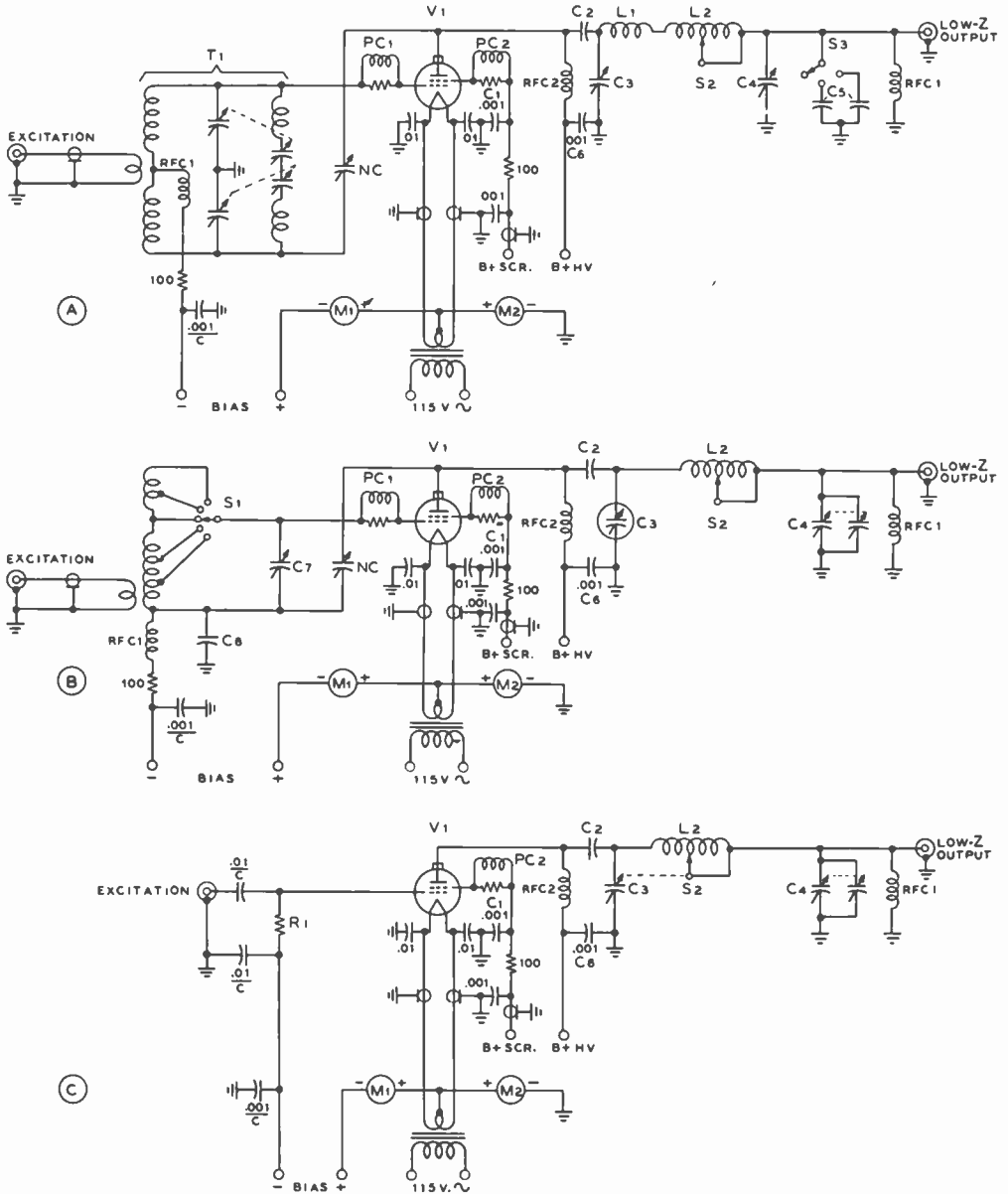

Figure 4

TYPICAL PI-NETWORK CONFIGURATIONS

A—Split grid circuit provides out-of-phase voltage for grid neutralization of tetrode tube. Rotary coil is employed in plate circuit, with small, fixed auxiliary coil for 28 MHz. Multiple tuning grid tank T, covers 3.5-30 MHz without switching

B—Tapped grid and plate inductors are used with "bridge-type" neutralizing circuit for tetrode amplifier stage. Vacuum tuning capacitor is used in input section of pi-network

C—Untuned input circuit (resistance loaded) and plate inductor ganged with tuning capacitor comprise simple amplifier configuration. R₁ is usually 50-ohm, 100-watt carbon resistor. PC₁, PC₂,—57-ohm, 2-watt composition resistor, wound with 3 turns #12 enam. wire

Note: Alternatively, PC₁ may be placed in the plate lead.

ground potential by completing the circuit to ground through the choke (RFC₁). Great stress is placed on the plate-circuit choke (RFC₂). This component must be specially designed for this mode of operation, having low interturn capacitance and no spurious internal resonances throughout the operating range of the amplifier.

Parasitic suppression is accomplished by means of chokes PC₁ and PC₂ in the screen, grid, or plate leads of the tetrode. Suitable values for these chokes are given in the parts list of figure 4. Effective parasitic suppression is dependent to a large degree on the choice of screen bypass capacitor C₁. This component must have extremely low inductance throughout the operating range of the amplifier and well up into the vhf parasitic range. The capacitor must have a voltage rating equal to at least twice the screen potential (four times the screen potential for plate modulation). There are practically no capacitors available that will perform this difficult task. One satisfactory solution is to allow the amplifier chassis to form one plate of the screen capacitor. A "sandwich" is built on the chassis with a sheet of insulating material of high dielectric constant and a matching metal sheet which forms the screen side of the capacitance. A capacitor of this type has very low internal inductance but is very bulky and takes up valuable space beneath the chassis. One suitable capacitor for this position is the *Centralab type 858S-1000*, rated at 1000 pf at 5000 volts. This compact ceramic capacitor has relatively low internal inductance and may be mounted to the chassis by a 6-32 bolt. Further screen isolation may be provided by a shielded power lead, isolated from the screen by a .001- μ f ceramic capacitor and a 100-ohm carbon resistor.

Various forms of the basic pi-network amplifier are shown in figure 4. The A configuration employs the so-called "all-band" grid-tank circuit and a rotary pi-network coil in the plate circuit. The B circuit uses coil switching in the grid circuit, bridge neutralization, and a tapped pi-network coil with a vacuum tuning capacitor. Figure 4C shows an interesting circuit that is becoming more popular for class-AB₁

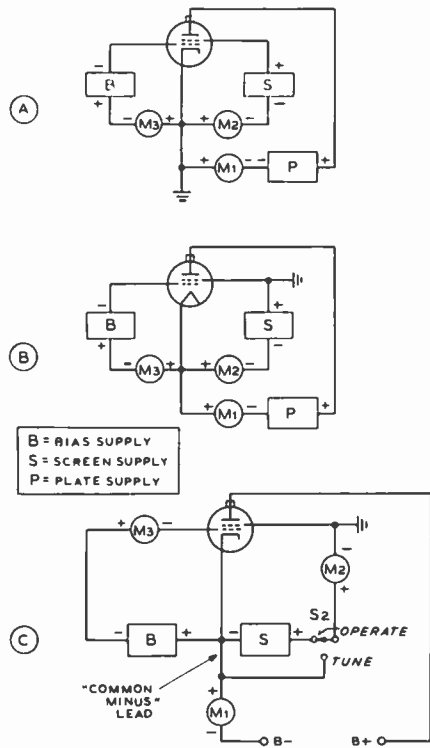

Figure 5

GROUNDED-SCREEN-GRID CONFIGURATION PROVIDES HIGH ORDER OF ISOLATION IN TETRODE AMPLIFIER STAGE

- A—Typical amplifier circuit has cathode return at ground potential. All circuits return to cathode.
- B—All circuits return to cathode, but ground point has been shifted to screen terminal of tube. Operation of the circuit remains the same, as potential differences between elements of the tube are the same as in circuit A.
- C—Practical grounded-screen circuit. "Common minus" lead returns to negative of plate supply, which cannot be grounded. Switch S₂ removes screen voltage for tune-up purposes.

linear operation. A tetrode tube operating under class-AB₁ conditions draws no grid current and requires no grid-driving power. Only r-f voltage is required for proper operation. It is possible therefore to dispense with the usual tuned grid circuit and neutralizing capacitor and in their place employ a noninductive load resistor in the grid circuit

across which the required excitation voltage may be developed. This resistor can be of the order of 50 to 300 ohms, depending on circuit requirements. Considerable power must be dissipated in the resistor to develop sufficient grid swing, but driving power is often cheaper to obtain than the cost of the usual grid-circuit components. In addition, the low-impedance grid return removes the tendency toward instability that is often common to the circuits of figures 4A and 4B. Neutralization is not required of the circuit of figure 4C, and in many cases parasitic suppression may be omitted. The price that must be paid is the additional excitation that is required to develop operating voltage across grid resistor R_1 .

The pi-network circuit of figure 4C is interesting in that the rotary coil (L_2) and the plate tuning capacitor (C_3) are ganged together by a gear train, enabling the circuit to be tuned to resonance with one panel control instead of the two required by the circuit of figure 4A. Careful design of the rotary inductor will permit the elimination of the auxiliary high-frequency coil (L_1), thus reducing the cost and complexity of the circuit.

The Grounded-Screen Configuration For maximum shielding, it is necessary to operate the tetrode tube with the screen at r-f ground potential. As the screen has a d-c potential applied to it (in grid-driven circuits), it must be bypassed to ground to provide the necessary r-f return. The bypass capacitor employed must perform efficiently over a vast frequency spectrum that includes the operating range plus the region of possible vhf parasitic oscillations. This is a large order, and the usual bypass capacitors possess sufficient inductance to introduce regeneration into the screen circuit, degrading the grid-plate shielding to a marked degree. Nonlinearity and self-oscillation can be the result of this loss of circuit isolation. A solution to this problem is to eliminate the screen bypass capacitor, by grounding the screen terminals of the tube by means of a low-inductance strap. Screen voltage is then applied to the tube by grounding the positive terminal of the screen supply, and "floating" the negative of the

screen and bias supplies below ground potential as shown in figure 5. Meters are placed in the separate-circuit cathode return leads, and each meter reads only the current flowing in that particular circuit. Operation of this grounded-screen circuit is normal in all respects, and it may be applied to any form of grid-driven tetrode amplifier with good results.

The Inductively Tuned Tank Circuit The output capacitance of large transmitting tubes and the residual circuit capacitance are often sufficiently great to prevent the plate tank circuit from having the desired value of Q , especially in the upper reaches of the h-f range (28- to 54-MHz). Where tank capacitance values are small, it is possible for the output capacitance of the tube to be greater than the maximum desired value of tank capacitance. In some cases, it is possible to permit the circuit to operate with higher-than-normal Q , however this expedient is unsatisfactory when circulating tank current is high, as it usually is in high-frequency amplifiers.

A practical alternative is to employ *inductive tuning* and to dispense entirely with the input tuning capacitor which usually has a high minimum value of capacitance (figure 6). The input capacitance of the circuit is thus reduced to that of the output capacitance of the tube which may be more nearly the desired value. Circuit resonance is established by varying the inductance of the tank coil with a movable, shorted turn, or loop, which may be made of a short length of copper water pipe of the proper diameter. The shorted turn is inserted within the tank coil by a lead-screw mechanism, or it may be mounted at an angle within the coil and rotated so that its plane travels from a parallel to an oblique position with respect to the coil. The shorted turn should be silver plated and have no joints to hold r-f losses to a minimum. Due attention should be given to the driving mechanism so that unwanted, parasitic shorted turns do not exist in this device.

Push-Pull Tetrode Circuitry Tetrode tubes may be employed in push-pull amplifiers, although the modern

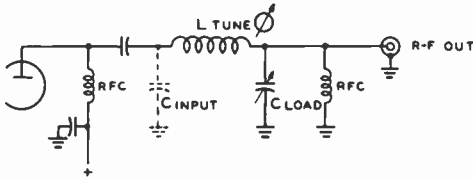

Figure 6

INDUCTIVE TUNING ELIMINATES INPUT TUNING CAPACITOR

trend is to parallel operation of these tubes. A typical circuit for push-pull operation is shown in figure 7. The remarks concerning the filament supply, plate feed, and grid bias in Section 28-1 apply equally to tetrode stages. Because of the high circuit gain of the tetrode amplifier, extreme care must be taken to limit intrastage feedback to an absolute minimum. It must be remembered with high-gain tubes of this type that almost full output can be obtained with practically

zero grid excitation. Any minute amount of energy fed back from the plate circuit to the grid circuit can cause instability or oscillation. *Unless suitable precautions are incorporated in the electrical and mechanical design of the amplifier, this energy feedback will inevitably occur.*

Fortunately these precautions are simple. The grid and filament circuits must be isolated from the plate circuit. This is done by placing these circuits in an "electrically tight" box. All leads departing from this box are bypassed and filtered so that no r-f energy can pass along the leads into the box. This restricts the energy leakage path between the plate and grid circuits to the residual plate-to-grid capacity of the tetrode tubes. This capacity is of the order of 0.25 pf per tube, and under normal conditions is sufficient to produce a highly regenerative condition in the amplifier. Whether or not the amplifier will actually break into oscillation is dependent upon circuit loading and residual lead inductance of the stage. Suffice to say that unless the tubes are actually neutralized a condition exists that will lead to circuit instability and oscillation under certain operating conditions.

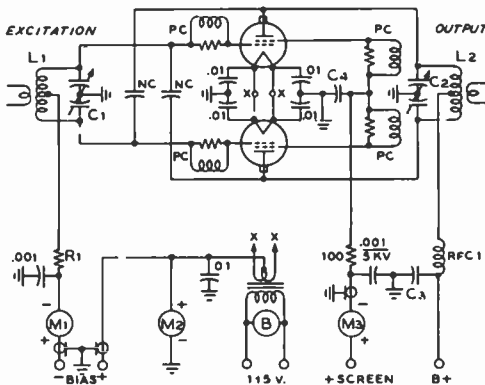

Figure 7

REPRESENTATIVE PUSH-PULL TETRODE AMPLIFIER CIRCUIT

The push-pull tetrode amplifier uses many of the same components required by the triode amplifier of figure 2. Parasitic suppressors may be placed in grid, screen, or plate leads. A low-inductance screen capacitor is required for proper amplifier operation. Capacitor C₁ may be .001 μfd, 5 kV. Centralab type 8385-1000. Strap multiple screen terminals together at socket with 1/2-inch copper strap for operation below 30 MHz and attach PC to center of strap. Blower required for many medium- and high-power tetrode tubes to cool filament and plate seals.

Amplifier Construction The push-pull tetrode amplifier should be designed around "r-f tight" boxes for the grid- and plate-circuit assemblies (figure 8). The tetrodes are mounted on the chassis which forms the common shield plate between the boxes. The grid circuit is placed below the chassis and all power leads into and out of this area are bypassed and shielded within the compartment.

The base shells of the tubes are grounded by spring clips, and short adjustable rods project up beside each tube to act as neutralizing capacitors. The leads to these rods are cross-connected beneath the chassis and the rods provide a small value of capacitance to the plates of the tubes. This neutralization is necessary when the tube is operated with high power gain and high screen voltage. As the operating frequency of the tube is increased, the inductance of the internal screen support lead of the tube becomes an important part of the screen ground-return circuit. At some critical frequency (about

45 MHz for the 4-250A tube) the screen-lead inductance causes a series-resonant condition and the tube is said to be "self-neutralized" at this frequency. Above this frequency the screen of the tetrode tube cannot be held at ground potential by the usual screen bypass capacitors. With normal circuitry, the tetrode tube will have a tendency to self-oscillate somewhere in the 120- to 160-MHz region. Low-capacity tetrodes that can operate efficiently at such a high frequency are capable of generating robust parasitic oscillations in this region while the operator is vainly trying to get them operating at some lower frequency. The solution is to introduce enough loss in the circuit at the frequency of the parasitic to render oscillation impossible.

Parasitic suppression is required with most modern high-gain tetrodes and may take place in either the plate or screen circuit.

In some instances, suppressors are required in the grid circuit as well. Design of the suppressor is a cut-and-try process: if the inductor of the suppressor has too few turns, the parasitic oscillation will not be adequately suppressed. Too many turns on the suppressor will allow too great an amount of fundamental frequency power to be absorbed by the suppressor and it will overheat and be destroyed. From 3 to 5 turns of #12 wire in parallel with a 50-ohm, 2-watt composition resistor will usually suffice for operation in the h-f region. At 50 MHz, the suppressor inductor may take the form of a length of copper strap (often a section of the plate lead) shunted by the suppressor resistor.

VHF Push-Pull Tetrode Amplifiers The circuit considerations for the vhf triode amplifier configuration

apply equally well to the push-pull tetrode circuit shown in figure 9. The neutralization techniques applied to the tetrode tube, however, may vary as the frequency of operation of the amplifier varies about the *self-neutralizing* frequency of the tetrode tube. At or near the upper frequency limit of operation, the inductance of the screen-grid lead of the tetrode cannot be ignored as it becomes of importance. Passage of r-f current through the screen lead produces a potential drop in the lead which may or may not be in phase with the grid voltage impressed on the tube. At the self-neutralizing frequency of the tube, the tube is inherently neutralized due to the voltage and current divisions within the tube which place the grid at the filament potential as far as plate-circuit action is concerned (see Chapter 11, Section 6). When the tetrode tube is operated below this frequency, normal neutralizing circuits apply; operation at the self-neutralizing frequency normally does not require neutralization, provided the input and output circuits are well shielded. Operation above the self-neutralizing frequency (in the range of 25 MHz to 100 MHz for large glass tubes, and in the range of 120 MHz to 600 MHz for ceramic, vhf tubes) requires neutralization, which may take the form of a series screen-tuning capacitor, such as shown in the illustration.

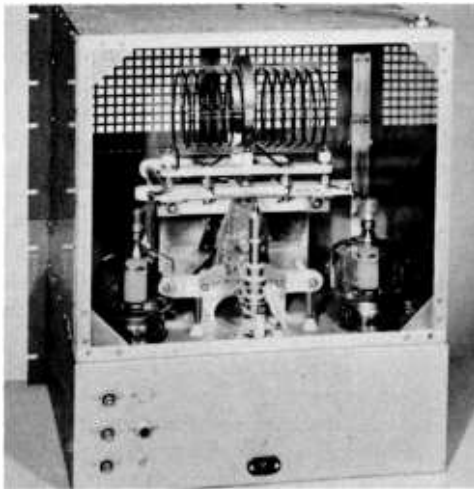

Figure 8

**REAR VIEW OF PUSH-PULL
4-250A AMPLIFIER**

The neutralizing rods are mounted on ceramic feedthrough insulators adjacent to each tube socket. Low voltage power leads leave the grid-circuit compartment via bypass capacitors located on the lower left corner of the chassis. A screen plate covers the rear of the amplifier during operation. This plate was removed for the photograph.

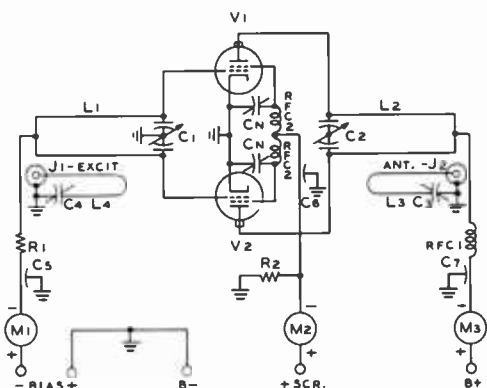

Figure 9

REPRESENTATIVE VHF PUSH-PULL TETRODE AMPLIFIER CIRCUIT

Tuned lines are used in grid and plate tank circuits in place of lumped inductances. Each screen circuit is series resonated to ground by neutralizing capacitor C_N . Wirewound resistor (R_2) is used in the grid-return circuit and frequency-rated r-f chokes in the plate and screen power leads. Screen resistor is included to complete screen-to-ground circuit, as discussed in text. Vhf type feedthrough capacitors are used for maximum suppression of r-f currents in power leads.

Neutralization is frequency sensitive and the amplifier should be neutralized at the operating frequency. Adjustment is conducted so as to reduce the power fed from the grid to the plate circuit. The amplifier may be driven with a test signal (filament and d-c voltages removed) and the signal in the plate tank circuit measured with an r-f voltmeter. The neutralizing capacitors are adjusted in unison until a minimum of fed-through voltage is measured. A good null will be obtained provided that intrastage feedback is reduced to a minimum by proper shielding and lead-bypassing techniques.

28-3 Cathode-Driven Amplifier Design

The *cathode-driven*, or *grounded-grid* amplifier has achieved astounding popularity in recent years as a high-power linear stage for sideband application. Various versions of this circuit are illustrated in figure 10. In the basic circuit the control grid of the tube is at r-f ground potential and the exciting

signal is applied to the cathode by means of a tuned circuit. Since the grid of the tube is grounded, it serves as a shield between the input and output circuits, making neutralization unnecessary in many instances. The very small plate-to-cathode capacitance of most tubes permits a minimum of intrastage coupling below 30 MHz. In addition, when zero-bias triodes or tetrodes are used, screen or bias supplies are not usually required.

Feedthrough Power A portion of the exciting power appears in the plate circuit of the grounded-grid (cathode-driven) amplifier and is termed *feedthrough* power. In any amplifier of this type, whether it be triode or tetrode, it is desirable to have a large ratio of feedthrough power to peak grid-driving power. The feedthrough power acts as a swamping resistor across the driving circuit to stabilize the effects of grid loading. The ratio of feedthrough power to driving power should be about 10 to 1 for best stage linearity. The feedthrough power provides the user with added output power he would not obtain from a more conventional circuit. The driver stage for the grounded-grid amplifier must, of course, supply the normal excitation power plus the feedthrough power. Many commercial sideband exciters have power output capabilities of the order of 70 to 100 watts and are thus well suited to drive high-power grounded-grid linear amplifier stages whose total excitation requirements fall within this range.

Distortion Products Laboratory measurements made on various tubes in the circuit of figure 10A show that a distortion reduction of the order of 5 to 10 decibels in odd-order products can be obtained by operating the tube in cathode-driven service as opposed to grid-driven service. The improvement in distortion varies from tube type to tube type, but some order of improvement is noted for all tube types tested. Most amateur-type transmitting tubes provide signal-to-distortion ratios of -20 to -30 decibels at full output in class-AB₁ grid-driven operation. The ratio increases to approximately -25 to -40 decibels for class-B grounded-grid operation. Distortion improvement is substantial, but

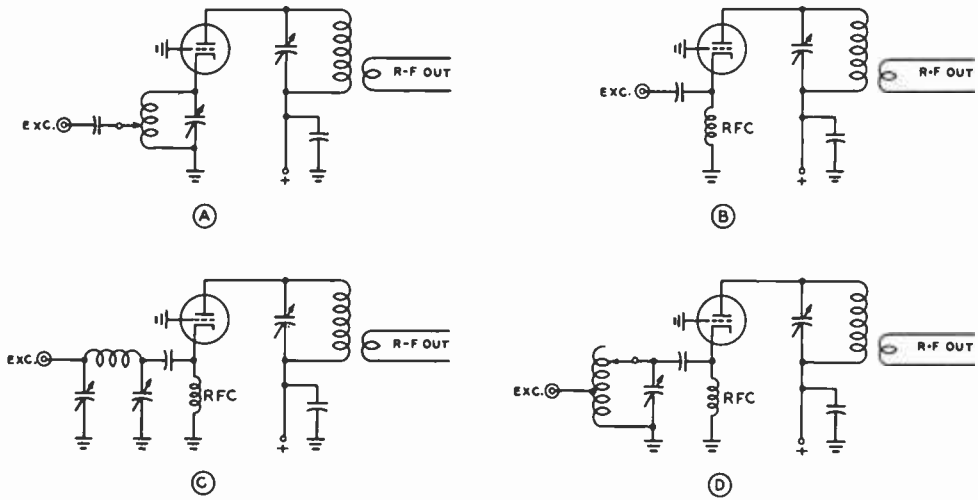

Figure 10

THE CATHODE-DRIVEN AMPLIFIER

Widely used as a linear amplifier for sideband service, the cathode-driven (g-g) circuit provides economy and simplicity, in addition to a worthwhile reduction in intermodulation distortion. A—The basic g-g amplifier employs tuned input circuit. B—A simplified circuit employs untuned r-f choke in cathode in place of the tuned circuit. Linearity and power output are inferior compared to circuit of figure A. C—Simple high-C pi-network may be used to match output impedance of sideband exciter to input impedance of grounded-grid stage. D—Parallel-tuned, high-C circuit may be employed for bandswitching amplifier. Excitation tap is adjusted to provide low value of SWR on exciter coaxial line.

not as great as might otherwise be assumed from the large amount of feedback inherent in the grounded-grid circuit.

A simplified version of the grounded-grid amplifier is shown in figure 10B. This configuration utilizes an untuned input circuit, circuit of figure 10A. It has inherent limitations, however, that should be recognized. In general, slightly less power output and efficiency is observed with the untuned-cathode circuit, odd-order distortion products run 4 to 6 decibels higher, and the circuit is harder to drive and match to the exciter than is the tuned-cathode circuit of figure 10A. Best results are obtained when the coaxial line of the driver stage is very short—a few feet or so. Optimum linearity requires cathode-circuit Q that can only be supplied by a high-C tank circuit.

Since the single-ended class-B grounded-grid linear amplifier draws grid current on only one-half (or less) of the operating cycle, the sideband exciter "sees" a low-impedance load during this time, and a very

high-impedance load over the balance of the cycle. Linearity of the exciter is thereby affected and the distortion products of the exciter are enhanced. Thus, the *driving signal* is degraded in the cathode circuit of the grounded-grid stage unless the unbalanced input impedance can be modified in some fashion. A high-C tuned circuit, stores enough energy over the operating r-f cycle so that the exciter "sees" a relatively constant load at all times. In addition, the tuned circuit may be tapped or otherwise adjusted so that the SWR on the coaxial line coupling the exciter to the amplifier is relatively low. This is a great advantage, particularly in the case of those exciters having fixed-ratio pi-network output circuits designed expressly for a 50-ohm termination.

Finally, it must be noted that removal of the tuned cathode circuit breaks the amplifier plate-circuit return to the cathode, and r-f plate-current pulses must return to the cathode via the outer shield of the driver coaxial line and back via the center con-

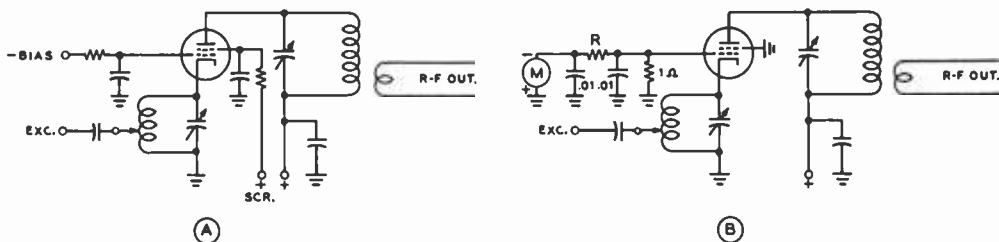

Figure 11

TETRODE TUBES MAY BE USED IN CATHODE-DRIVEN AMPLIFIERS

A—Tetrode tube may be used in cathode-driven configuration, with bias and screen voltages applied to elements which are at r-f ground potential. **B**—Grid current of grounded-grid tube is easily monitored by RC network which lifts grid above ground sufficiently to permit a millivoltmeter to indicate voltage drop across 1-ohm resistor. Meter is a 0-1 d-c milliammeter in series with appropriate multiplier resistor.

ductor! Extreme fluctuations in exciter loading, intermodulation distortion, and TVI can be noticed by changing the length of the cable between the exciter and the grounded-grid amplifier when an untuned-cathode input circuit and a long interconnecting coaxial line are used.

Cathode-Driven Amplifier Design features of the single-ended and push-pull amplifiers discussed previously

Construction apply equally well to the grounded-grid stage. The g-g linear amplifier may have either configuration, although the majority of the g-g stages are single ended, as push-pull offers no distinct advantages and adds greatly to circuit complexity.

The *cathode circuit* of the amplifier is resonated to the operating frequency by means of a high-C tank (figure 10A). Resonance is indicated by maximum grid current of the stage. A low value of SWR on the driver coaxial line may be achieved by adjusting the tap on the tuned circuit, or by varying the capacitors of the pi-network (figure 10C). Correct adjustments will produce minimum SWR and maximum amplifier grid current at the same settings. The cathode tank should have a Q of 2 or more.

The cathode circuit should be completely shielded from the plate circuit. It is common practice to mount the cathode components in an "r-f tight" box below the chassis of the amplifier, and to place the plate circuit components in a screened box above the chassis.

The *grid (or screen) circuit* of the tube is operated at r-f ground potential, or may have d-c voltage applied to it to determine the operating parameters of the stage (figure 11A). In either case, the r-f path to ground must be short, and have extremely low inductance, otherwise the screening action of the element will be impaired. The grid (and screen) therefore, must be bypassed to ground over a frequency range that includes the operating spectrum as well as the region of possible vhf parasitic oscillations. This is quite a large order. The inherent inductance of the usual bypass capacitor plus the length of element lead within the tube is often sufficient to introduce enough regeneration into the circuit to degrade the linearity of the amplifier at high signal levels even though the instability is not great enough to cause parasitic oscillation. In addition, it is often desired to "unground" the grounded screen or grid sufficiently to permit a metering circuit to be inserted.

One practical solution to these problems is to shunt the tube element to ground by means of a 1-ohm composition resistor, bypassed with a .01- μ fd ceramic disc capacitor. The voltage drop caused by the flow of grid (or screen) current through the resistor can easily be measured by a millivoltmeter whose scale is calibrated in terms of element current (figure 11B).

The *plate circuit* of the grounded-grid amplifier is conventional, and either pi-network or inductive coupling to the load may be used. There is some evidence to support

the belief that intermodulation distortion products are reduced by employing plate circuit Q 's somewhat higher than normally used in class-C amplifier design. A circuit Q of 10 or greater is thus recommended for ground-grid amplifier plate circuits.

Tuning the Grounded-Grid Amplifier Since the input and output circuits of the grounded-grid amplifier are in series, a certain proportion of driving power appears in the output circuit. If full excitation is applied to the stage and the output circuit is opened, or the plate voltage removed from the tube, practically all of the driving power will be dissipated by the grid of the tube. Overheating of this element will quickly occur under these circumstances, followed by damage to the tube. Full excitation should therefore never be applied to a grounded-grid stage unless plate voltage is applied beforehand, and the stage is loaded to the antenna.

Tuneup for sideband operation consists of applying full plate voltage and sufficient excitation (carrier injection) so that a small rise in resting plate (cathode) current is noted. The plate loading capacitor is set near full capacitance and the plate tank capacitor is adjusted for resonance (minimum plate current). Drive is advanced until grid current is noted and the plate circuit is loaded by decreasing the capacitance of the plate loading capacitor. The drive is increased until about one-half normal grid current flows, and loading is continued (re-resonating the plate tank capacitor as required) until loading is near normal. Finally, grid drive and loading are adjusted until PEP-condition plate and grid currents are normal. The values of plate and grid current should be logged for future reference. At this point, the amplifier is loaded to the maximum PEP input condition. In most cases, the amplifier and power supply are capable of operation at this power level for only a short period of time, and it is not recommended that this condition be permitted for more than a minute or two.

The exciter is now switched to the SSB mode and, with speech excitation, the grid and plate currents of the cathode-driven stage should rise to approximately 40 to 50

percent of the previously logged PEP readings. The exact amount of meter movement with speech is variable and depends on meter damping and the peak to average ratio of the particular voice. Under no circumstances, however, should the voice meter readings exceed 50 percent of the PEP adjustment readings unless some form of speech compression is in use.

To properly load a linear amplifier for the so-called "two-kilowatt PEP" condition, it is necessary for the amplifier to be tuned and loaded at the two-kilowatt level, albeit briefly. It is necessary to use a dummy load to comply with the FCC regulations, or else a special test signal must be used. To achieve a ratio of 2:1 between the tune-up condition and the PEP condition an audio pulser and single-tone driving signal may be used. Shown in figure 12 is a pulser having a duty cycle of about 0.44. For a d-c meter reading of 880 watts input using the pulser and a single audio tone, the PEP input level and corresponding amplifier loading adjustments will satisfy the two-kilowatt PEP conditions. An oscilloscope and audio oscillator are necessary to conduct this exercise, but these instruments are required items for any well-equipped sideband station.

For best linearity, the output circuit of the grounded-grid stage should be overcoupled so that power output drops about 2-percent from maximum value. A simple output r-f voltmeter is indispensable for proper circuit adjustment. Excessive grid current is a sign of antenna undercoupling, and overcoupling is indicated by a rapid drop in output power. Proper grounded-grid stage operation can be determined by finding the optimum ratio between grid and plate current and by adjusting the drive level and loading to maintain this ratio. Many manufacturers now provide grounded-grid operation data for their tubes, and the ratio of grid to plate current can be determined from the data for each particular tube.

Choice of Tubes for G-G Service Not all tubes are suitable for grounded-grid service.

In addition, the signal-to-distortion ratio of the suitable tubes varies over a wide range. Some of the best g-g performers are the 811A, 813, 7094, 4-125A,

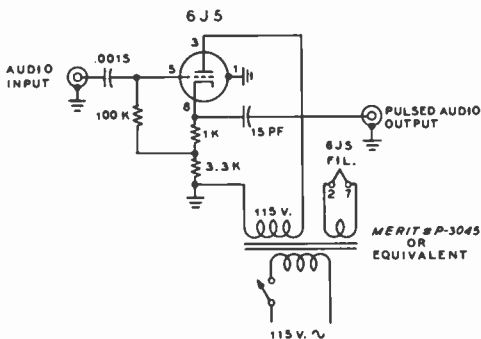

Figure 12

AUDIO PULSER FOR HIGH-POWER TUNE-UP OF AMPLIFIER

This simple audio pulser modifies the audio signal to the sideband exciter so that it has a high peak-to-average power ratio. Amplifier may be thus tuned for two kilowatt PEP input without violating the one-kilowatt maximum steady-state condition.

4-250A, 4-400A, and 4-1000A. In addition, the 3-400Z, 3-500Z, and 3-1000Z triodes are specifically designed for low distortion, grounded-grid amplifier service.

Certain types of tetrodes, exemplified by the 4-65A, 4X150A, 4CX300A, and 4CX-1000A should not be used as grounded-grid amplifiers unless grid bias and screen voltage are applied to the elements of the tube (figure 11A). The internal structure of these tubes permits unusually high values of grid current to flow when true grounded-grid circuitry is used, and the tube may be easily damaged by this mode of operation.

The efficiency of a typical cathode-driven amplifier runs between 55- and 65-percent, indicating that the tube employed should have plenty of plate dissipation. In general, the PEP input in watts to a tube operating in grounded-grid configuration can safely be about 2.5 to 3 times the rated plate dissipation. Because of the relatively low average-to-peak power of the human voice it is tempting to push this ratio to a higher figure in order to obtain more output from a given tube. This action is unwise in that the odd-order distortion products rise rapidly when the tube is overloaded, and because no safety margin is left for tuning errors or circuit adjustments.

Neutralization of the G-G Stage At some high frequency the shielding action of the grid of the g-g amplifier deteriorates. Neutralization may be necessary at higher frequencies either because of the presence of inductance between the active grid element and the common returns of the input and output circuit, or because of excessive plate-cathode capacitance.

Neutralization, where required, may be accomplished by feeding out-of-phase energy from the plate circuit to the filament circuit (figure 13A) or by inserting a reactance in series with the grid (figure 13B). For values of plate-cathode capacitance normally encountered in tubes usable in g-g service, the residual inductance in the grid-ground path provides sufficient reactance, and in some cases even series capacitance will be required. Typical tube electrode capacitances are shown in figure 14A. These can be represented by an equivalent star connection of three capacitors (figure 14B). If an inductance (L) is placed in series with C_G so that a resonant circuit is formed (figure 14C), point O will be at ground potential (14D). This prevents the transfer of energy from point P to point K, since there now exists no common coupling impedance. The determination of value C_G and L are shown in figure 14.

It is apparent that when the plate-cathode capacitance of the tube is small as compared to the plate-grid and the grid-cathode capacitance, C_G is a large value and the required value of inductance L is small. In practical cases the value of L is supplied by the tube and lead inductance, and the grid-to-ground impedance can be closely adjusted by proper choice of the bias bypass capacitor (figure 13B). Below a certain frequency determined by the physical geometry of the tube, neutralization may be accomplished by adding inductance to the grid-return lead; above this frequency it may be necessary to series tune the circuit for minimum energy feedthrough from cathode to plate. Most tubes are sufficiently well screened so that series inductive neutralization at the lower frequencies is unnecessary, but series capacitance tuning of the grid-return lead may be required to prevent oscillation at some parasitic frequency in the vhf range.

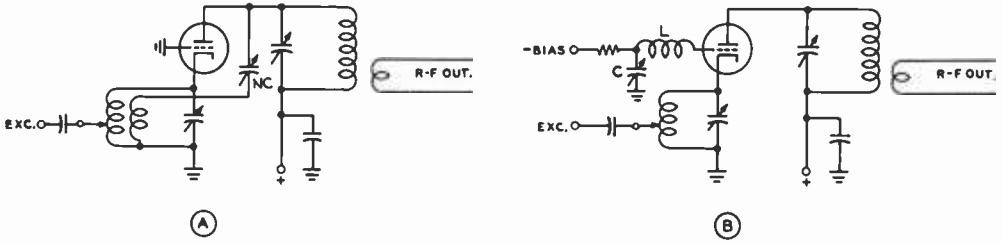

Figure 13

NEUTRALIZING CIRCUITS FOR CATHODE-DRIVEN STAGES

Neutralization of the g-g stage may be necessary at the higher frequencies. Energy fed back in proper phase from plate to cathode is used to neutralize the unwanted energy fed through the tube (A). Reactance placed in series with the grid return lead (B) will accomplish the same result. The inductance (L) usually consists of the internal grid lead of the tube, and capacitor C may be the grid bypass capacitor. A series-resonant circuit at the operating frequency is thus formed.

28-4 1-kW Economy Linear Amplifier

A vast amount of money can be spent on high-power transmitting equipment. On the other hand, excellent results may be obtained from proper use of inexpensive components and tubes. A multiplicity of TV sweep tubes have often been used in linear-amplifier service at the 1-kW PEP level, but this interesting approach seems to have created more problems that it has solved. In order to achieve proper distribution of power, the

sweep tubes must be closely matched in terms of perveance, or an adjustable bias supply must be provided for each tube. In addition, when one tube begins to carry less than its share of the total power, a greater burden is thrust on the remaining tubes whose operating lives are shortened as a result of the increased load.

The use of inexpensive transmitting-type high-μ triodes such as the 811A is highly recommended in place of the multiple sweep-tube approach, since the larger tube has ample plate dissipation and filament emission to withstand the power level, and pro-

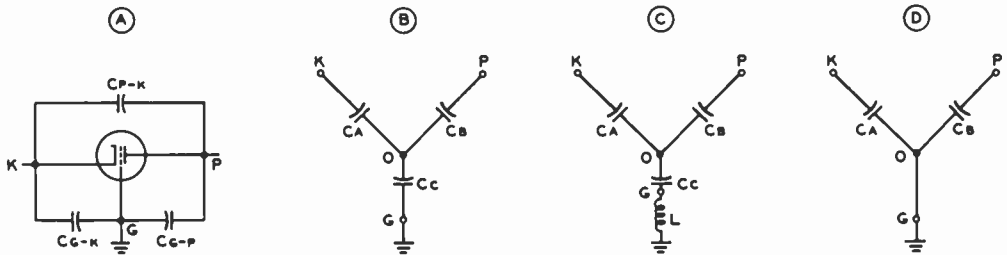

$$C_c = \frac{(C_{P-G} \times C_{P-K}) \pm (C_{P-K} \times C_{G-K}) \pm (C_{G-K} \times C_{P-G})}{C_{P-K}}$$

$$L = \frac{1}{(2\pi f)^2 \times C_c}$$

Figure 14

Tube electrode capacitances can be represented by an equivalent star connection of three capacitors. If inductance is placed in series with C_c so that a resonant circuit is formed (drawing C), point O will be at ground potential.

vides good operating life. The use of four 811A tubes in parallel, moreover, allows ample safety factor at the 1-kW PEP level and requires no expensive and complicated balancing circuits to make them share the power load evenly.

Shown in this section is a 1000-watt PEP linear amplifier for use on amateur bands between 80 and 10 meters which makes use of four 811A triodes connected in grounded-grid configuration. This inexpensive amplifier is a good "beginners' project" in the field of single sideband.

The Amplifier Circuit The circuit of the 811A linear amplifier is shown in figure 16. A conventional grounded-grid (cathode-driven) configuration is used, with provision for neutralization added. The four tubes are strapped in parallel, providing a total of over 260 watts

plate dissipation without the need for forced-air cooling. At a plate potential of about 1500 volts and a total plate current of 650 ma, the full 1000-watt PEP input level is reached at a PEP drive level of about 80 watts. The drive requirement is compatible with the output power of most modern SSB exciters and transceivers.

Referring to the schematic of figure 16, separate tuned input circuits are used for each band, and are switched into the filament circuit by bandswitch S_1 . A third winding on the filament choke is used for neutralization. The plate circuit consists of a pi network using a commercially available inductor (L_6 - L_7) and an inexpensive ceramic bandswitch. On the 80-meter band position, an additional output capacitor is switched in parallel with the loading capacitor (C_7) to match the low antenna impedances often found on this band.



Figure 15

1-KW PEP ECONOMY LINEAR AMPLIFIER

Designed for operation between 3.5 MHz and 29.7 MHz this economical linear amplifier uses four 811A tubes in parallel, operating at 1500 volts. The amplifier may be driven by an SSB exciter or transceiver having 80 watts PEP output, or more. The amplifier is built within a homemade cabinet, the top, sides and back of which are made of perforated aluminum. The front panel and cowl are made of aluminum sheet. The unit is given a spray coat of zinc chromate paint, and an overcoat of gray paint.

At the upper left are the grid and plate milliammeters. One milliamperere d-c meters are used, shunted to the desired range. The grid meter reads 200 ma full scale and the plate meter reads one ampere, full scale. Below the meters is the cathode circuit bandswitch. At the center of the panel is the plate tank tuning capacitor dial, with the filament and plate power switches directly beneath. To the right is the plate bandswitch, with the filament and plate pilot lamps above. At the lower right is the plate loading capacitor (labelled "Antenna Loading").

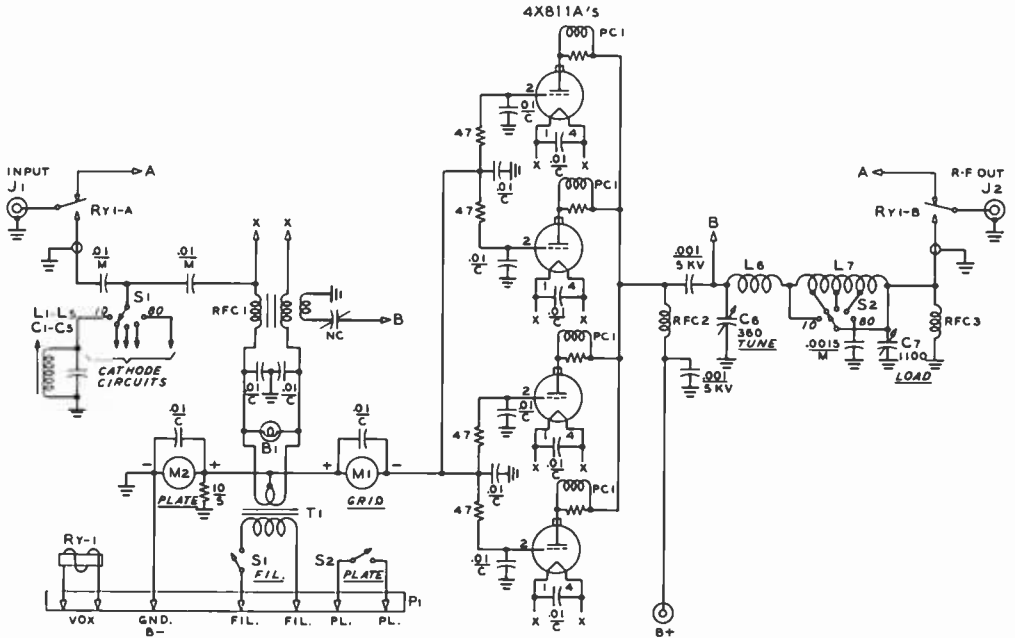

Figure 16

SCHEMATIC, 811A LINEAR AMPLIFIER

- C₁—200-pf mica capacitor, 500-volt
- C₂, C₃—470-pf mica capacitor, 500-volt
- C₄, C₅—1000-pf mica capacitor, 500-volt
- C₆—360-pf, 2.5 kV Johnson 154-2
- C₇—1160-pf, three-section receiving capacitor (broadcast type)
- C₈—0.0015-μfd, 1250-volt mica capacitor. Sangamo type H
- NC—Neutralizing capacitor. Approx. 15 pf, 1.25 kV. Use 100-pf midget capacitor with alternate plates removed to leave six stator plates and seven rotor plates.
- L₁, L₂—(0.15 μH) 4 turns #16 on National XR-50 form, or equiv., 1/2-inch diameter. Powdered iron slug removed from both coils.
- L₃, L₄—(0.3 μH) 6 turns #16 on National XR-50 form, or equiv., slug removed from coil L₄.
- L₅—(0.15 μH) 13 turns, as L₂.
- L₆, L₇—Air-Dux pi-network assembly 195-1. Modify as per text. Grid-dips as follows:

- 80 meters: C₁-310 pf, C₂-2000 pf; 40 meters: C₁-150 pf, C₂-1000 pf; 20 meters: C₁-75 pf, C₂-500 pf; 15 meters: C₁-50 pf, C₂-350 pf; 10 meters: C₁-35 pf, C₂-250 pf. Above capacitances include output capacitance of tubes.
- RFC₁—16-ampere choke. 20 turns #12 enamel wire, bifilar wound (2 windings, 20 turns each) on ferrite core (1/2-inch diameter. Indiana General CF-501, Q-1 material. Cut and break rod to length). Newark Electronics catalog number 59F-1519. Neutralizing coil: Seven turns #18 closewound around tube end of choke in same direction as bifilar winding.
- RFC₂—200 μH, 1 ampere. B & W 800, or Jennings Industries RFC-800
- RFC₃—2 mH, 100 ma. National R-100 or equiv.
- PC₁—4 turns #18 wound over 47-ohm 2-watt composition resistor. Turns spaced the length of the resistor
- T₁—6.3 volts at 16 amperes

Each grid of the 811A combination is placed at r-f ground potential by a bypass capacitor mounted on the individual tube socket, and d-c grid return is completed through a simple resistance-capacitance filter network and a meter (M₁) to permit grid-current measurement. The plate-current meter (M₂) is placed in the B-minus lead to the power supply.

A built-in VOX relay provides change-over for the antenna circuit and can be actuated by the VOX control circuitry of

the exciter. Plate voltage is applied to the amplifier in the standby condition unless the external power supply is switched off.

Amplifier Construction The general amplifier layout is shown in the top and bottom photographs. The unit is built on an aluminum chassis measuring 10" X 17" X 3" and fits within a home-made cabinet made of a U-shaped dust cover of perforated aluminum. A bottom plate and back piece are made of the same material.

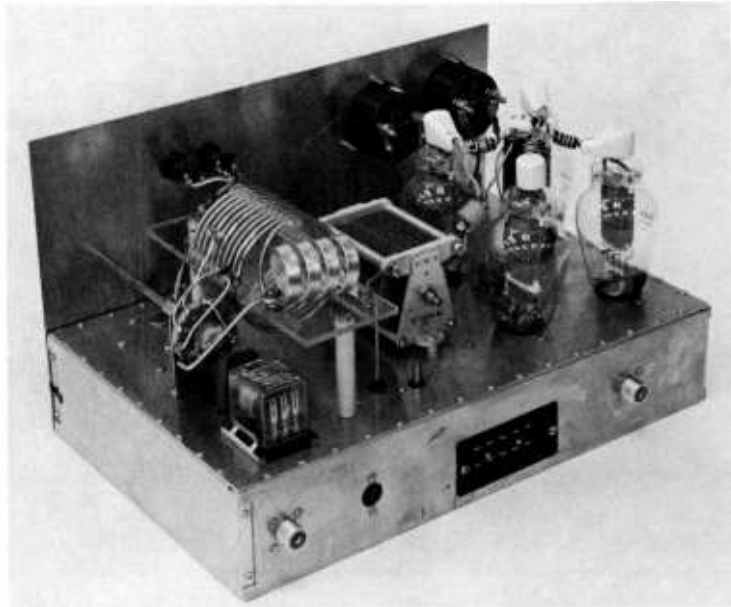

Figure 17

REAR VIEW OF 811A LINEAR AMPLIFIER

The four 811A tubes are positioned at one end of the chassis, with the plate-tuning capacitor at the center. To the left is the pi-network inductor mounted on ceramic standoff insulators. The plate-circuit bandswitch and VOX relay are at the chassis edge. The shaft of the neutralizing capacitor may be seen in the foreground projecting through the chassis.

Along the rear lip of the chassis are (l. to r.): Antenna coaxial connector (J₁), auxiliary 115-volt power plug, main power receptacle (P), and input receptacle (J₂). Filament transformer in this amplifier was mounted in the nearby power supply and parallel pin connections in plug were used to carry the heavy filament current.

Layout of parts is not critical, provided reasonable care is taken to provide short, direct leads in the plate and filament circuits. The plate tuning capacitor (C₆) is centered on the chassis, with the tubes grouped at the corners of a square at one end of the chassis. The plate r-f choke (RFC₂) is placed at the center of this square, with the B-plus bypass capacitor mounted immediately beside the choke, atop the chassis.

The 811A tube sockets are recessed below the chassis deck on metal pillars to lower the over-all tube height, while the plate tank-coil assembly is mounted on ceramic insulators to bring the center line of the main coil even with the top terminal of the plate-tuning capacitor. Adjacent to the coil, the plate-circuit bandswitch (S₂) is placed on a small aluminum bracket to align the shaft height of the switch with the shaft height of the plate-tuning capacitor. The switch is driven by an extension shaft to permit the switch to be mounted near the "hot" end of the coil (at the junction of coil L₆ and low-frequency coil L₇).

Below deck, the cathode tank assembly and plate-loading capacitor are placed at

opposite ends of the chassis. The distance of the capacitor below the deck is adjusted with metal spacers to make the shaft height the same as that of the cathode bandswitch. Adjacent to the 811A sockets is the filament r-f choke.

The Filament Choke—The filament choke (RFC₁) is home-made, or a commercial substitute may be altered to fit the job. The choke is a bifilar winding of two coils, as described in the parts list, with a third small winding placed over the choke, the tube end going to ground, and the opposite end attached to the neutralizing capacitor (NC). The capacitor is placed near the rear of the underchassis area and is mounted on small ceramic insulators, as it has a very high r-f potential to ground. The stator of the capacitor is connected to one terminal (B) of coil L₆, as shown in the schematic.

The Plate Coil Assembly—The plate inductor is modified from a commercial unit, or may be made from ready-wound coil stock. The 10-meter coil is separate, and is made of 5/16-inch wide copper strap. As is, the inductance of the commercial coil is too high for optimum circuit Q at 10 meters.

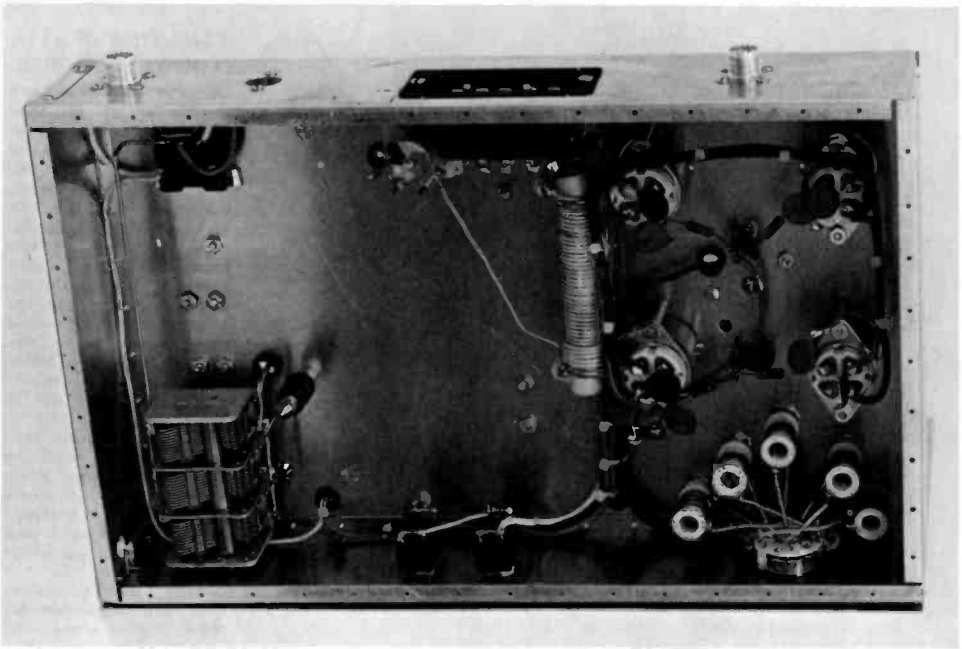

Figure 18

UNDER-CHASSIS VIEW OF 811A LINEAR AMPLIFIER

The filament choke and 811A tube sockets are at the right, with the tuned cathode circuit grouped about the bandswitch (S_1). At the left is the antenna loading capacitor (C_2) and RFC. Neutralizing capacitor is mounted on standoff insulators adjacent to main power receptacle at the rear of the chassis. Ample space exists below chassis to mount filament transformer, if desired.

About $\frac{1}{2}$ inch of strap is cut from one end and the new end drilled. The diameter of the coil is squeezed a bit to produce a modified coil of four turns, with an inside diameter of $1\frac{3}{8}$ inches.

The low-frequency coil (L_7) must also be modified for proper operation. The coil is cut to 11 turns, trimmed, and the new end firmly bolted to the plastic support plate in the original mounting hole. Taps are now soldered to the coil as follows: From the junction with the 10-meter coil; 15-meter tap, 1 turn; 20-meter tap, 3 turns; 40-meter tap, 6 turns. The tap leads may be made of thin $\frac{1}{8}$ -inch wide copper strap, or #12 copper wire. The tap leads are all dressed to one side of the coil, as seen in the rear view photograph. The arm of the plate bandswitch is attached to the output end of the main coil, and the 80-meter mica loading capacitor is placed in a vertical position behind the bandswitch.

When the plate circuit is completely wired, the tubes are placed in their sockets

and the plate caps attached. Proper resonance for each band may be established by coupling a grid-dip oscillator to one end of the strap coil. The plate bandswitch is set for an appropriate band and the capacitance settings for the band, and the rest of the band checked against the approximate settings listed in figure 16. The settings of the capacitors may be estimated, or the units may be disconnected from the circuit and measured on a capacitance meter, if one is at hand. The value of capacitor C_1 indicated is the total capacitance of the capacitor plus the output capacitance of the tubes, the latter figure totalling about 25 pf. It may be necessary to shrink coil L_6 a bit to achieve resonance at the high end of the 10-meter band, because lead length and circuit layout are critical at this frequency.

Next, the cathode tanks should be resonated to the middle of each amateur band. The grid-dip oscillator is again used, and the slug of each cathode coil is adjusted until resonance is established with the cathode

bandswitch set for the proper band. Target resonant frequencies for each band are: 3.8 MHz, 7.2 MHz, 14.2 MHz, 21.2 MHz, and 29 MHz.

Amplifier Testing After the alignment is completed, the unit is ready for an operational check. A 1500-volt, 600-milliamperere power supply; SSB exciter; and an r-f power-output meter are required; plus a suitable antenna or dummy load. The plate and cathode bandswitches are set for the band in use and neutralization capacitor NC is placed in the zero capacitance (open) position. The amplifier cover and bottom plate are placed on the assembly, and the amplifier and power supply are bonded together with a safety ground wire.

Filament and plate voltages are applied and resting plate current should be observed to be about 125 milliamperes with no drive signal. Grid current should be zero. The setting of the plate-tuning capacitor (C_6) should be logged, then the control swung through the complete tuning range, while the operator observes the grid and plate meters. Both meters should remain at their original setting. Any variation in current while either the tuning or loading controls are adjusted at random (with no drive signal) indicates some form of instability. This test is the most demanding on the 10-meter band, and it is recommended that it be performed at this wavelength. If a fluctuation or variation of either grid or plate current is noted, neutralization capacitor C_6 should be slowly advanced until the perturbation ceases. Adjustment should be done with a phenolic (nonmetallic) screwdriver or rod. If, by chance, adjustment of the neutralization capacitor makes matters worse, it may be an indication that the neutralizing coil on the filament choke is incorrectly polarized, and the connections should be reversed. Under normal circumstances, neutralization is rarely required, except at the high end of the 10-meter band. For lower frequencies, the capacitor probably will be set at zero.

Carrier excitation is now applied to the amplifier until an indication of about 20 ma grid current is observed. The plate-tuning capacitor is adjusted for an indication of resonance, noted by a dip in amplifier

plate current. The power-output meter is monitored and grid drive raised a bit, while tuning and loading are adjusted for maximum power output. Antenna loading and grid drive are gradually increased until a plate current of about 650 ma is achieved at a grid-current reading of 100 to 120 ma. The final step is to retune the plate-tuning capacitor for minimum plate current at the 650-ma region. The goal is to achieve maximum output with minimum drive level consistent with the aforementioned grid- and plate-current figures.

Under tuneup conditions, plate dissipation reaches the maximum level and it is recommended that tuneup be limited to 15-second periods of time every 30 seconds. Once the proper adjustment point has been reached, the dial settings should be logged for future use. With carrier removed, plate current should drop back to the no-signal level. Under SSB modulation, grid and plate currents should kick up to about one half the carrier values for full 1000 watts PEP input.

28-5 The KW-1 All Band Linear Amplifier Using Two 4CX300A's

This compact desk-top linear amplifier (figure 19) is an improved version of the popular "Tribander" amplifier featured in the past editions of the Handbook. The newly designed unit includes operation on all bands between 3.5 MHz and 29.7 MHz with good efficiency. It features an electron tuning tube and loading indicator that permits quick tuneup and adjustment after changing bands. The KW-1 amplifier uses two 4CX300A ceramic tetrode tubes in a class-AB₁ mode, cathode-driven configuration. If desired, 4CX250B or 4X150A tubes may be substituted for the 4CX-300A's with no decrease in performance. The KW-1 amplifier is small enough to be placed on the operating table next to an SSB transceiver or exciter. Provisions are included for operating the exciter without the amplifier. At 2000 volts plate potential, third-order distortion products of the amplifier are better than -30 decibels below one tone of a two-tone test signal. The am-



Figure 19
THE KW-1 ALL-BAND LINEAR AMPLIFIER

The KW-1 desk-top linear amplifier provides 1-kw PEP input on amateur bands between 80 and 10 meters. A pair of 4CX300A tetrodes is used in class-AB₁ cathode-driven service. The amplifier features an electron tuning eye which permits quick tuneup and adjustment after changing bands.

Panel controls (l. to r.) are: High-voltage primary circuit breaker and pilot lamp, with filament switch and pilot lamp below; and current and output meters, with bandswitch below. At the left of the bandswitch is the plate/screen meter switch and at the right is the forward/reflected switch for the built-in SWR meter. At the right of the panel are the amplifier tuning control (top) and loading control (bottom). At the left of the controls is the tune/operate switch.

Directly above the panel meters is the electron tuning tube. The panel mask is cut from a phenolic sheet and painted black to match the meters. The panel is painted with a flat green enamel and lettering is applied. The panel is then given a protective spray of clear plastic (Krylon) paint to protect the lettering. Knobs are General Radio products.

plifier is designed for continuous service, and may be run at full input for RTTY service.

The Amplifier Circuit A high perveance tetrode such as the 4CX300A cannot be used in conventional zero-bias, class-B grounded-grid circuitry, since the element geometry within the tube leads to abnormally high values of grid current and possible destructive values of grid dissipation. The distortion reduction characteristics of cathode-driven circuitry, however, may be retained with these tubes if class-AB₁

grid and screen d-c operating potentials are applied to the tubes. The schematic of the KW-1 amplifier featuring this circuit is shown in figure 20. The driving signal is applied to the cathode circuit as is done in the more common grounded-grid configuration. Grid and screen elements of the tubes are at r-f ground, while normal d-c class AB₁ grid bias and screen potentials are used. Thus, the power gain of the 4CX300A's is quite high, approximately 30 watts PEP drive level being required for 1000 watts PEP input. Since the amplifier is designed to be connected to the exciter with a very

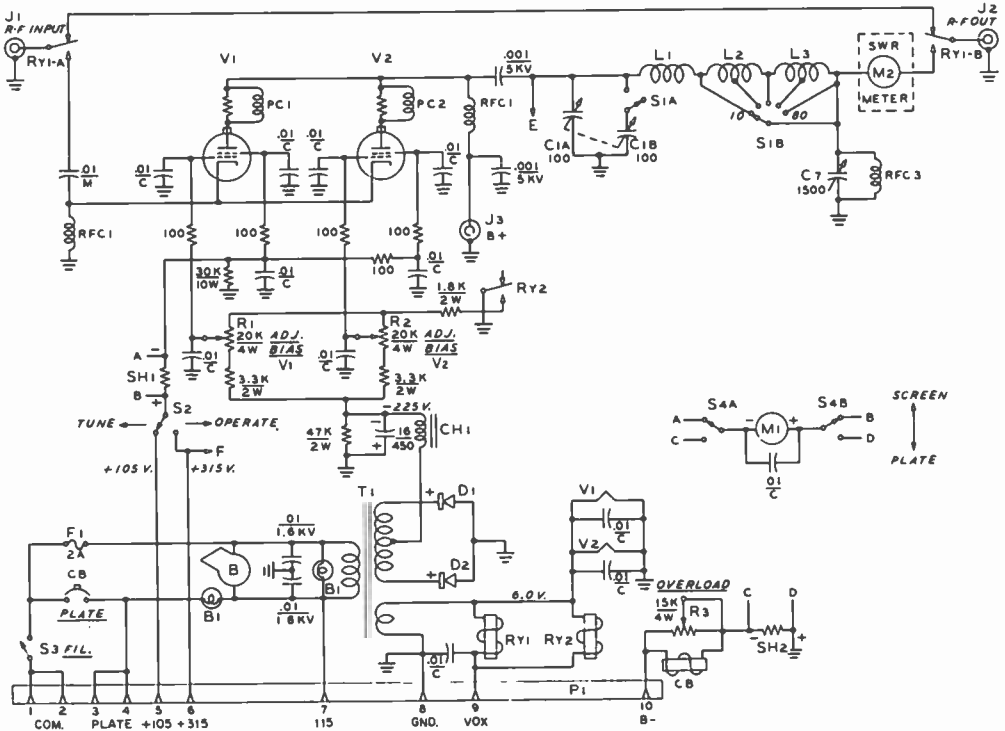

Figure 20

SCHEMATIC, KW-1 AMPLIFIER

- C_{1A', B'}—Split stator, 100-pf per section, .07" spacing. La Pointe Industries 108-12
- C₂—1500 pf, .03" spacing. La Pointe Industries 104-12, or Jackson 4595/3/380 (LE-3). (M. Swedgal, 258 Broadway, N.Y., N.Y. 10007)
- L₁—(10-meter coil) 4 turns, 3/16" copper tubing, 2 1/4" inside diam., 3" long
- L₂—(15-20 meter coil) 6 1/2 turns, 1/8" copper tubing, 2" inside diam., 3" long. Tap at center
- L₃—(40-80 meter coil) 20 turns #14 (6 t.p.i.), 2 1/4" diam., 3 1/4" long. Tap at center
- RFC₁, RFC₂—(84 μH) rated at 600 ma. J.W. Miller RFC-14
- RFC₃—2.5 mH. J. W. Miller 4537
- RY₁—Dpdt, ceramic insulation, 6.3-volt coil
- RY₂—Spst, 6.3-volt coil
- PC₁, PC₂—3 turns #16 spaced around 47-ohm, 2-watt composition resistor
- CH₁—12 H, 30 ma. Stancor C-2318

- T₁—460-volt, center tapped at 50 ma, 6.3 volts at 5 amp, Stancor P-8155. Remove turns from filament winding to provide 6.0 volts under load
- B—Ripley 81 (left hand) with 2 3/4" impeller, 3100 r.p.m., 58 c.f.m.
- J₁, J₂—coaxial receptacle, SO-239
- S_{1A', B'}—2-pole, 6-position. Radio Switch Corp. (Marlboro, N. J.) Model 86 with two style A rotors (standard)
- SH₁—10 ohms, 1-watt
- SH₂—500-ma shunt to match meter movement
- CB—500-ma circuit breaker (Heinemann), 15-amp service.
- M₁—0-50 d-c milliamperes. Calibrate scale for 0-50 and 0-500 ma ranges
- D₁, D₂—1N4005, 600-volt PIV, 1 amp
- Sockets—Eimac SK-760 for 4CX300A. Eimac SK-640 plus SK-606 chimney for 4X150A and 4CX250B

short length of coaxial line, a tuned-cathode circuit is not used, the output-circuit Q of the exciter being sufficient to preserve the waveform of the driving signal.

Provisions are included in the KW-1 linear amplifier to electrically balance the two tubes by adjustment of individual grid bias, permitting each tube to draw the proper plate current regardless of minor varia-

tions between tubes. Adjust bias potentiometers R₁ and R₂ allow sufficient variation in bias to achieve this condition. A built-in bias supply provides -225 volts and the VOX relay (RY₂) permits plate-current cutoff in the receive mode.

Filament voltage for the 4CX300As is 6.0 volts, a special transformer being used to provide bias and filament voltage. Separate

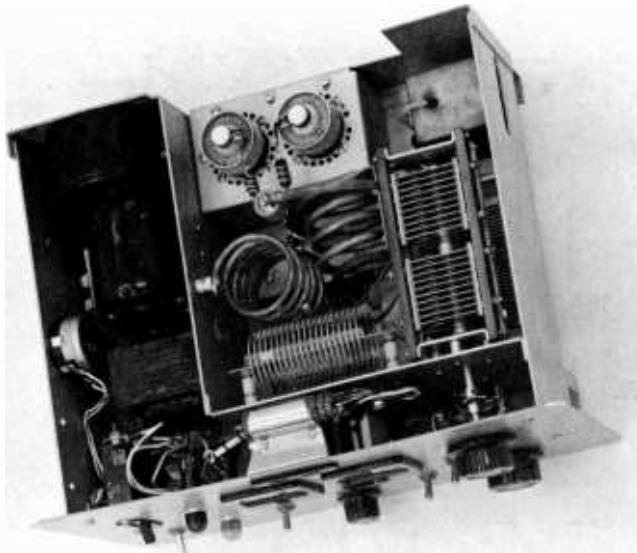

Figure 21
TOP VIEW OF KW-1
AMPLIFIER

Center compartment contains the main r-f components. At the rear are the two 4CX300A tubes mounted on a small chassis adjacent to the blower. To the right of the tubes is the small drawn aluminum case containing the output reflectometer. Plate loading and tuning capacitors are mounted at the right of the compartment on the front subpanel. Central area contains the three plate-circuit inductors and the band-switch. Low- and medium-frequency inductors are mounted to the sides of the compartment with small ceramic stand-off insulators, and the high-frequency coil is supported by bandswitch and tuning capacitor. The plate r-f choke is placed vertically at the rear of the compartment with the plate-blocking capacitor atop it. The blower, filament transformer, and auxiliary components are mounted to the left of the r-f compartment. The circuit breaker overload potentiometer (R₁) is mounted to the outer wall of the enclosure. Electron tuning tube is mounted to the front panel by a bracket which encircles the tube.

transformers may be substituted at lower cost, if desired.

Amplifier Plate Circuit—The KW-1 amplifier plate circuit is a pi-network arrangement, with additional plate tuning capacitance (C_{1B}) added to the circuit by means of switch deck S_{1A} on the 80- and 40-meter bands. The plate tank coil is divided into three sections having taps for the various ranges. It is designed to couple to a 50-ohm antenna system having an SWR of 3/1 or less. An RL parasitic suppressor is placed in the plate lead of each tube to inhibit vhf oscillation. Neutralization is not required, and the linear amplifier remains stable over the complete operating range.

An SWR meter (M_2) is incorporated in the amplifier as an aid in tuneup and is a duplicate of the instrument described in Chapter 31 (figures 28-31). The components of the reflectometer are mounted in a small aluminum box in a corner of the amplifier area of the chassis (figure 21).

The instantaneous r-f plate voltage of the amplifier is sampled at *point E* by a capacitive voltage divider. A portion of the voltage is rectified by diode D_1 and is used as automatic-load-control (ALC) voltage for

the exciter (figure 23). A second rectified voltage is used to energize the 6FG6 electron tuning tube, mounted on the front panel of the amplifier. The tube is used to establish proper plate-circuit loading. Under no signal conditions, the pattern of the tube is open, gradually closing with increased signal voltage until at maximum voltage the pattern is closed, showing a solid green bar in the viewing portion of the tube.

This indication corresponds to maximum amplifier PEP input. The sensitivity of both the ALC and tuning tube circuits is adjustable by means of capacitors C_3 and C_4 .

The linear amplifier is biased to plate-current cutoff in the standby position by relay RY_2 which opens the bias return circuit and places maximum negative bias on the tubes. Standby plate current is reduced to virtually zero, permitting the use of an IVS-rated power supply (see Power-Supply chapter) with the amplifier. Diode noise in a nearby receiver is also eliminated during periods of reception.

Amplifier Construction The amplifier is built on a homemade aluminum chassis measuring 14" \times 9 1/2" in area,

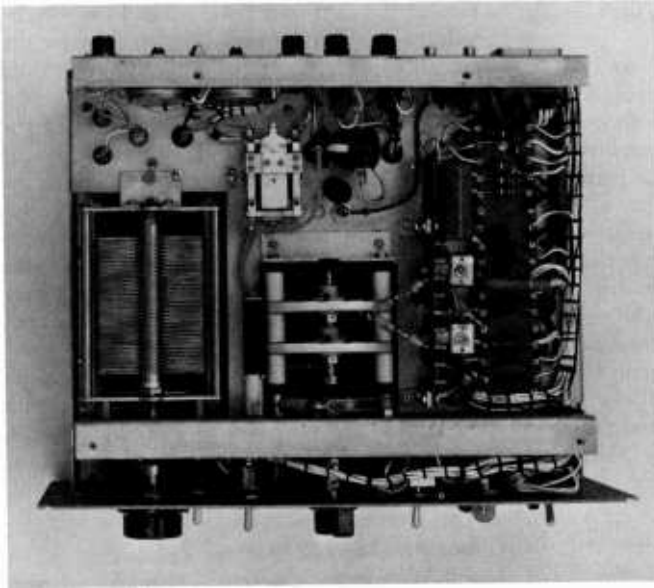

Figure 22
UNDER-CHASSIS VIEW OF
KW-1 LINEAR AMPLIFIER

The main chassis is cut out to clear loading capacitor (left) and bandswitch (center). Directly behind bandswitch are antenna-changeover and VOX relays, with bias potentiometers, coaxial receptacles, fuse, and power plug mounted on the rear lip of the chassis. At the right are the two phenolic strips holding the smaller circuit components. The strip at the left is mounted on edge and holds adjustment capacitors C₃ and C₄. Each 1-pf coupling capacitor is composed of two 2-pf, 3-kV ceramic capacitors connected in series. Wiring between panel controls and terminal strips is laced and run along edge of chassis. The front and back lips of the chassis are turned under so that the unit may be bolted to the ventilated cabinet.

and having a depth of $2\frac{1}{8}$ ". Cutout areas in the chassis provide room for the main bandswitch and the pi-network output tuning capacitor. A box shield above the chassis separates the r-f area from the control circuits, blower and filament transformer. The two 4CX300A tubes and companion air-system sockets are mounted atop a small aluminum box at the rear of the main chassis. The box measures $5\frac{1}{4}$ " \times $3\frac{1}{4}$ " \times 2" high. The sockets, bypass networks and cathode r-f choke are placed in this box, one end of which has a square hole cut in it to match the opening of the blower. The cooling air enters the side of the box and is exhausted through the tube sockets and through a ring of $\frac{1}{8}$ -inch diameter holes drilled around the perimeter of the socket (figure 21). The three sections of the plate tank coil are placed in the center area of the chassis behind the bandswitch.

Placement of the major components beneath the chassis is seen in figure 22. The rear of the bandswitch and the pi-network loading capacitor (C₂) are affixed to small angle brackets bolted to the chassis. The various resistors and capacitors in the auxiliary control, bias, and screen circuits are mounted on two phenolic terminal boards placed near the edge of the chassis deck.

Each board is $1\frac{3}{4}$ " wide. The two variable mica compression capacitors (C₃ and C₄) are mounted to the vertical board by means of small aluminum brackets, and are adjust-

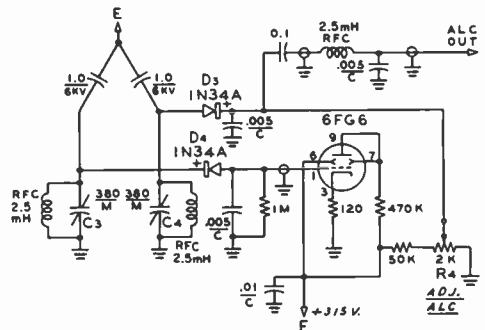

Figure 23
ELECTRON-EYE PEAK INDICATOR
AND ALC CIRCUITRY

The 6FG6/EM-84 tuning indicator is used for an r-f peak-level indicator in the KW-1 linear amplifier. R-f voltage is sampled, rectified, and applied to the gate (pin 1) of the indicator. The pattern is formed between the deflection elements (pins 6 and 7) and appears as a horizontal line. Amplitude of indication is adjustable by means of mica compression capacitor C₃. ALC control voltage is taken from plate circuit and magnitude established by capacitor C₄. Control point may be set by adjusting diode bias voltage with "Adjust ALC" potentiometer R₄.

300A (V_2) in the V_2 socket. Energize the amplifier and adjust bias potentiometer V_2 for 100 milliamperes plate current, as before. Mark the potentiometer positions with a pencil on the chassis lip. The plate balance should be checked every six months or so, or whenever the tubes are changed. Insert tube V_1 and now note that the plate current meter reads the combined resting plate current of 200 milliamperes. When the VOX control is released, plate current should drop to zero.

The KW-1 amplifier is now ready to place on the air. After filament warmup, the *Tune/Operate* switch is placed in the *tune* position. High voltage is applied and the VOX circuit energized. A small amount of carrier is applied to the amplifier from the exciter as a tuning signal until about 200 ma of plate current is indicated. The amplifier is now tuned to resonance. The 6FG6 electron-beam tube pattern should also start to close. Once resonance is established, the tuning and loading controls are adjusted for maximum power output as read on meter M_2 . The loading capacitor should be near full-capacitance for 80 meters, about 60-percent meshed for 40 meters, 30-percent meshed for 20 meters, and slightly less for 15 and 10 meters.

Carrier injection is now slowly raised until plate current reads about 300 milliamperes at resonance. Screen current will run between 10 and 30 milliamperes. Screen current is a very sensitive indication of loading. Too-low a value of screen current indicates the amplifier is either underdriven or overloaded. Conversely, too-high a value of screen current indicates the amplifier is either overdriven or underloaded. Note the screen meter reads about 10 milliamperes of bleeder current in addition to actual screen current. "Target" value of screen meter reading at full input is 20 ma to 30 ma at a plate current of 500 ma. Power output should be about 650 watts, or more at 1000 watts input.

The carrier is now removed and voice modulation applied. A maximum of 1000 watts PEP input may be achieved under these operating conditions. Screen and plate current should peak at about 15 ma and 250 ma, respectively.

Since no cathode tank circuit is used, it is recommended that the intercoupling coaxial line to the exciter be held to a length of three feet, or less, especially for 10- and 15-meter operation. Line lengths up to six feet or so may be tolerated at the lower operating frequencies.

Note that screen current peaks at the same resonance point at which plate current dips. This relationship is helpful when the amplifier is heavily loaded and plate-current dip is rather small. For precise tuning, the screen current peak should always be used as a condition of resonance, rather than the dip of plate current.

Once the amplifier is operating properly, the electron tuning tube may be adjusted so that the visual pattern completely closes at maximum input level under carrier conditions by adjustment of capacitor C_3 . Once properly set, maximum voice level is noted on the indicator by complete closing of the pattern. If the amplifier is improperly loaded, or overdriven, the pattern will overlap, with a bright green flash.

In similar fashion, the magnitude of the ALC voltage may be adjusted by the combination of capacitor C_4 and *ALC Adjustment* potentiometer R_4 . The potentiometer sets the ALC threshold voltage and the capacitor determines the maximum amount of ALC voltage. For c-w operation, carrier insertion is used, and the amplifier loaded to a plate-current value of 500 milliamperes.

28-6 The 500Z 2-kW PEP Linear Amplifier for 10 thru 80 Meters

Two 3-400Z or 3-500Z high- μ triode tubes form the basis for this compact, multi-band, high-power desk-top linear amplifier. Heavy-duty design combined with rugged components permit the amplifier to be run at full legal power level for SSB or c-w service. Measuring only 16" \times 8" \times 13" deep the amplifier is small enough to be placed on the operating table adjacent to the SSB transceiver or exciter.

Auxiliary circuitry permits the exciter to bypass the amplifier, if desired, for low-power operation, and the unit incorporates



Figure 25

TWO-KILOWATT PEP INPUT IS FEATURED IN THIS COMPACT AMPLIFIER USING ZERO BIAS TRIODES

This desk-top amplifier allows maximum PEP input on all high-frequency amateur bands. Two zero-bias 3-500Z triodes are used in a cathode-driven, grounded-grid circuit. ALC is included as well as a high-efficiency, low-noise fan cooling system.

The amplifier is housed in a perforated aluminum case and is entirely self-contained, except for the power supply. At the top of the front panel are the grid and plate meters. The antenna loading control (C.) is at the left and the plate tuning control (C_p) at the right. Both capacitors are driven through small precision planetary vernier drives. The bandswitch is centered at the lower portion of the panel.

The amplifier cabinet is gray, with light-green panel. After the lettering is applied, the panel is sprayed with clear Krylon enamel to protect the lettering. The unit is elevated above the desk top on rubber feet to permit good movement of air about the under-chassis area.

automatic load control (ALC) for optimum voice efficiency in SSB operation. At maximum input level, the third-order intermodulation products are better than -33 decibels below one tone of a two-tone test signal, attesting to the high degree of linearity attained without the use of auxiliary feedback circuitry. Peak drive power is of the order of 90 watts, and the amplifier may be driven by any SSB exciter capable of this power output.

The Amplifier Circuit This 2000-watt PEP linear amplifier employs two zero-bias triode tubes connected in cathode-driven, grounded-grid configuration. A pi-network output circuit is used, cap-

able of matching 50-ohm or 70-ohm coaxial antenna circuits. For improved linearity and ease of drive, a simple tuned-cathode input circuit is ganged to the pi-network amplifier bandswitch. Separate grid and plate meters are used and a variable ALC circuit is provided for connection to the exciter. The amplifier is designed for operation over a plate voltage range of 2000 to 2700 volts and a plate potential of 2500 volts is recommended.

Amplifier Circuitry—The schematic of the linear amplifier is shown in figure 26. Two 3-400Z or 3-500Z tubes are connected in parallel. Each of the three grid pins of the tube sockets is grounded, and the driving signal is applied to the filament circuit of

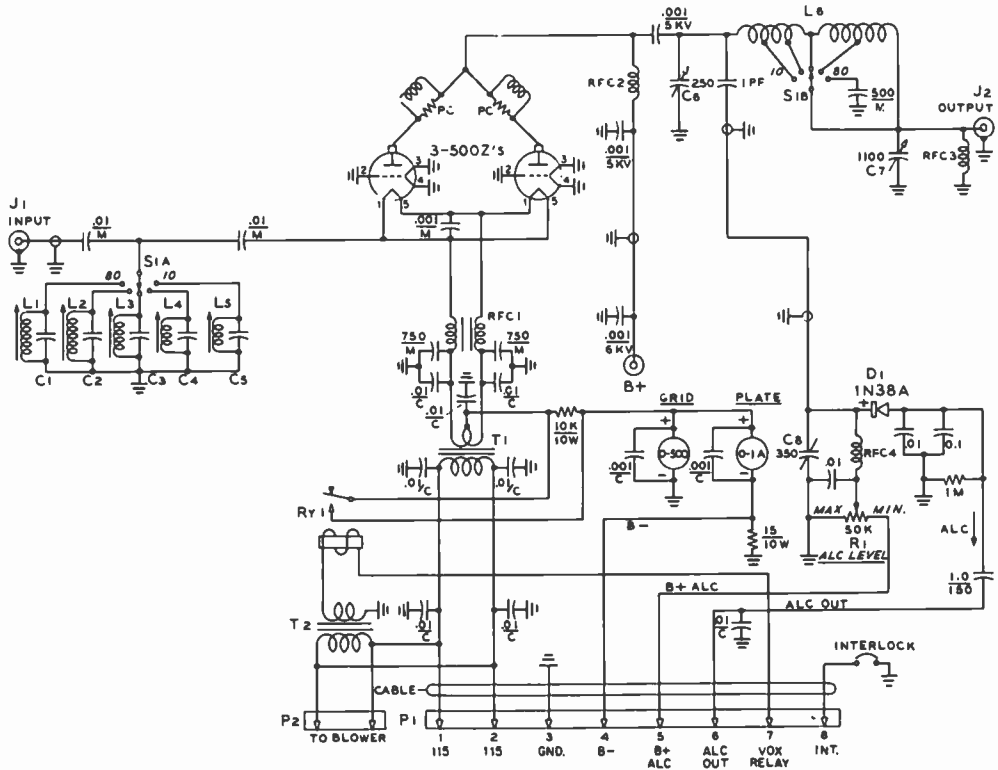

Figure 26
SCHEMATIC OF 500Z LINEAR AMPLIFIER

- C₁—200 pf, 2.5-kV mica. Sangamo H-5320
- C₂, C₃—470 pf, 2.5-kV mica. Sangamo H-5347
- C₄, C₅—1000 pf, 1.25-kV mica. Sangamo H-2210
- C₆—250 pf, 3-kV, .075" spacing. Johnson 154-9
- C₇—1100 pf, 3-section. Jackson Bros. LE3-4595-380 (M. Swedgal, 258 Broadway, N. Y. 10007)
- C₈—350-pf mica compression capacitor
- L₁, L₂—(0.15 μH) 4 turns #16 e. on 1/2" diam., form, powdered-iron core. National XR-50 or equiv. form. (Slug removed from both coils)
- L₃, L₄—(0.31 μH) 6 turns #14 e. on National XR-50 or equiv. form. (Slug removed from L₃).
- L₅—(1.3 μH) 13 turns # 18 e. on National XR-50 or equiv. form
- L₆—(10-15-20 meters) 10 1/2 turns #8 wire, 2" diam., 3 1/2" long. 10-meter tap is 5 1/4 turns from plate end; 15-meter tap, 7 1/4 turns. (40-80 meters) 16 turns # 10 wire, 2 1/2" diameter, 4" long. 40-meter tap is 8 turns from "hot" end. Coil wound on lucite plate with edges grooved for proper spacing of turns
- RPC₁—Bifilar winding. Each coil is 14 turns

- #10 e., on ferrite core, 5" long 1/2" diam. (Indiana General CF-503) (Newark Electronics catalog #59F-1521) Manufactured choke: Jennings Industries J1-PC32
- RFC₁—(Approx. 60 μH) 90 turns #26 e., spaced-wound wire diameter, 3 1/4" long, 3/4" diam. on ceramic or Teflon form. Series resonant at 26 MHz. Jennings Industries J1-PC800
- RFC₂, RFC₃—2.5 mH. National R-100
- T₁—5 volts, 30 amp. Stancor P-6492
- T₂—6.3 volts, 1 amp. Stancor P-8389
- RY₁—Spst, 6.3-volt coil
- Fan—Ripley SK-4125 or equivalent.
- Meters—Calstro
- PC₁—Three 100-ohm, 2-watt resistors in parallel. 3 1/2 turns #18 spacedwound about one resistor
- S_{1A}—Single-pole, 11-position ceramic switch, 30° Index. Centralab PA-6001.
- S_{1B}—Single-pole, 11-position ceramic switch, 30° Index. Radio Switch Corp. Model 86-A
- Sockets—Johnson 122-275-1
- Dials—General Radio with Jackson Bros. 4511-DAF Planetary Ball Drive Unit

the tubes, which is isolated from ground by a bifilar r-f choke. Neutralization is not required because of the excellent circuit isolation provided by the tubes and by the circuit layout.

The driving signal is fed in a balanced manner to the filament circuit of the two tubes. Mica capacitors suitable for r-f service are used to properly distribute the driving signal to the tuned-cathode circuit and

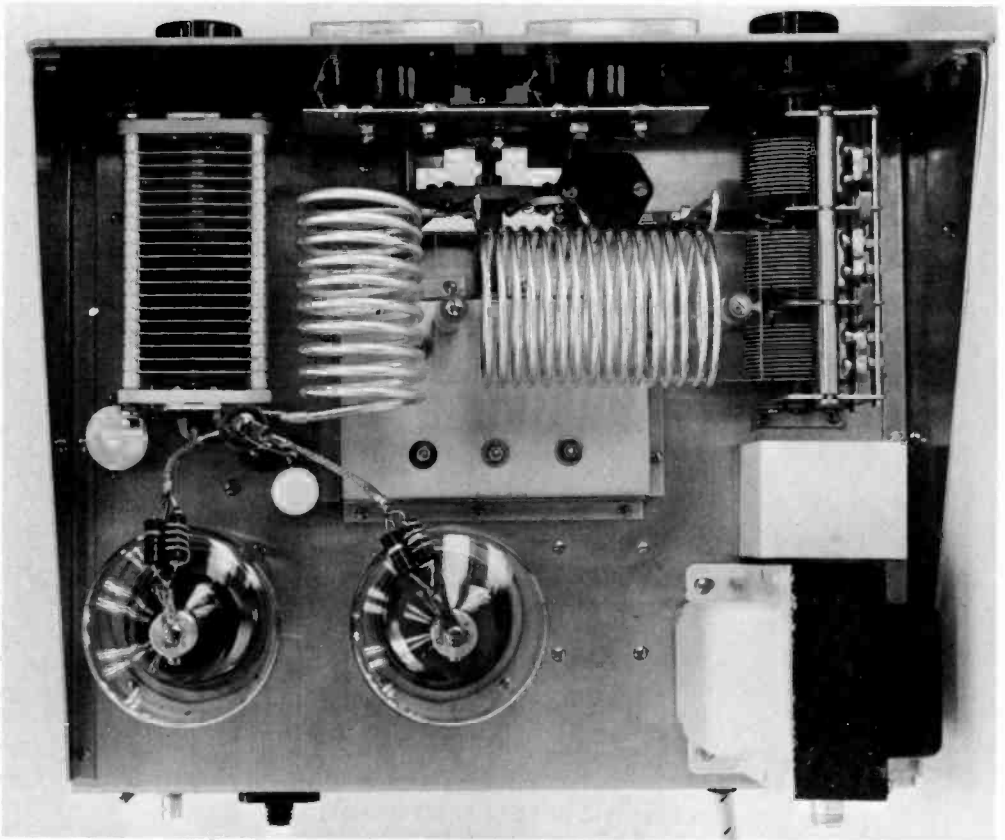

Figure 27

TOP VIEW OF LINEAR AMPLIFIER

Two 3-500Z tubes are placed at the rear corner of the amplifier chassis. The spacing of sockets and blower are shown in figure 31. The plate loading and tuning capacitors are mounted to each side of the pi-network coil assembly. The three stator sections of the output capacitor are connected in parallel by short lengths of copper strap. Directly below the plate coils is the aluminum box containing the cathode tuned circuits, with the adjustment slugs of the coils projecting through the top of the box.

The 500-pf auxiliary 80-meter loading capacitor is placed above the bandswitch, directly in front of the 80-40 meter coil. At the left, the 1-pf coupling capacitor is attached directly to the rotor of the main tuning capacitor (see figure 30).

The filament transformer for the two 3-500Z tubes is at the rear, right corner of the chassis. The portion of the transformer facing the tubes is painted white to reflect the infra-red radiation from the tubes, which run a cherry-red color at full plate dissipation level. The cooling fan is mounted to the rear of the cabinet, and is not seen in this view.

the filaments of the tubes. Ceramic-disc capacitors are not recommended for use in this portion of the circuit because the peak r-f current under full amplifier input may be as high as 6 amperes or so. The tuned-cathode circuits (L_1 - L_5) are fixed-tuned to the center of each amateur band and may be forgotten.

The Plate Circuit—Plate voltage is applied to the tubes through a heavy duty r-f

choke bypassed at the B-plus end by a low-inductance, ceramic capacitor. In addition, the high voltage passes through a length of shielded cable to the high-voltage connector at the back of the chassis, and is further bypassed to ground at that point. A single .001- μ fd, 5-kV ceramic capacitor is used for the high-voltage plate-blocking capacitor and is mounted atop the plate r-f choke. The pi-network coil is divided into two

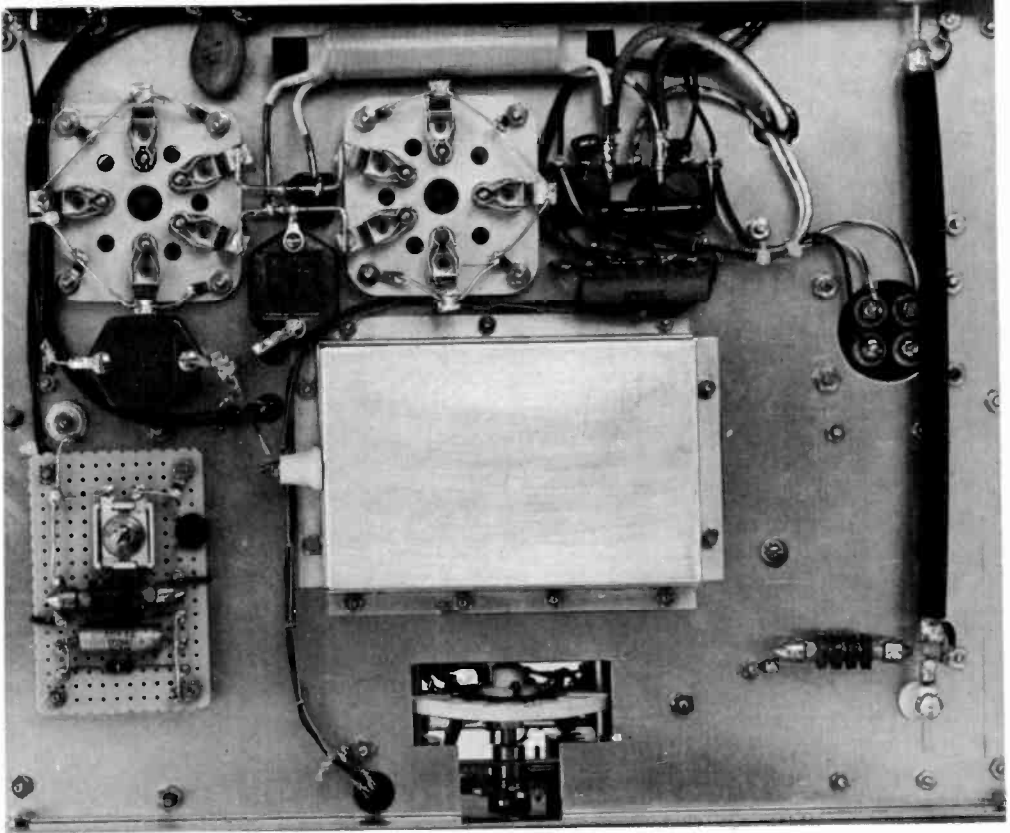

Figure 28

UNDER-CHASSIS VIEW OF AMPLIFIER

The cathode circuit box is at the center of the chassis, with the connecting load passing through a feedthrough insulator at the left. The shaft of switch S_{1A} passes through the wall of the upper section of the box, only about 1/16-inch above the level of the chassis and is joined to the plate bandswitch (S_{1B}) with a brass coupling.

The three grid pins of the tube sockets are grounded to the mounting bolts. The sockets are lowered below the chassis by means of spacers to permit cooling air to flow about the base of the tubes. The two .01- μ fd mica coupling capacitors are placed adjacent to the left-hand tube socket, with the ferrite-core filament choke running parallel to the rear of the chassis. Directly to the right of the sockets are placed two phenolic terminal strips which support the filament wiring, the 10K VOX resistor and the 15-ohm meter safety resistor. The bypass capacitors for the "cold" end of the filament choke are also located on one terminal strip.

At the right end of the chassis is a small phenolic board that holds mica compression capacitor C, and the components associated with the ALC circuit. The ALC level potentiometer is a small 3/4-inch diameter control mounted on the rear lip of the chassis, adjacent to input receptacle J_1 . To the right of J_1 is the high-voltage connector, with the .001- μ fd, 6-kV disc capacitor mounted behind it. The antenna output circuitry is at the right end of the chassis. The connection from the plate-loading capacitor passes through a ceramic feedthrough insulator near the panel, and the connection to the coaxial receptacle (J_2) at the rear of the amplifier is made via a short length of RG-8/U coaxial line. The outer braid of the line is grounded to the chassis at each end.

parts for highest efficiency and ease in assembly. The first portion covers 10, 15, and 20 meters, and an additional section is added to the first to cover operation on 40 and 80 meters. Both coils are homemade and air wound at a minimum cost. The bandswitch

is a *Radio Switch Corp.* high-voltage ceramic-insulated unit mounted to the front panel of the amplifier.

A typical circuit Q of 10 was chosen to permit a reasonable value of capacitance to be used at 80 meters and the number of

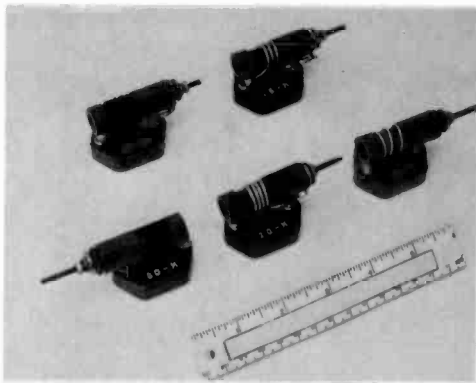

Figure 29

CATHODE COILS FOR AMPLIFIER

The mica capacitor is mounted to the terminals of the slug-tuned coil. The coils may be grid-dipped to frequency before they are placed in the aluminum coil box.

turns in the plate coils was adjusted to maintain this value of Q up through 15 meters. At 10 meters, the Q rises to about 18 and is largely determined by the minimum cir-

cuit capacitance achieved at this frequency. The pi-network output capacitor is a three-section, ceramic insulated 1100-pf unit. It is sufficiently large for proper operation of the amplifier on all bands through 40 meters. For 80-meter operation, an additional 500-pf heavy duty mica capacitor is switched in parallel with the variable unit to provide good operation into low-impedance antenna systems commonly found on this band. The capacitor is connected to the unused 80-meter position of the bandswitch.

The instantaneous r-f plate voltage is sampled by a capacitive voltage divider and applied to a reverse-biased rectifier (D_1). Bias level is set by means of an adjustable potentiometer (*ALC Level*). When the r-f voltage exceeds the bias level, an ALC pulse is applied to the ALC control circuit of the exciter. The r-f level applied to the control circuit is set by adjustment of capacitor C_8 and the voltage is determined by the ratio of this capacitor to the 1-pf capacitor coupling the ALC circuit to the plates of the amplifier tubes. At a plate potential of 2500 or so,

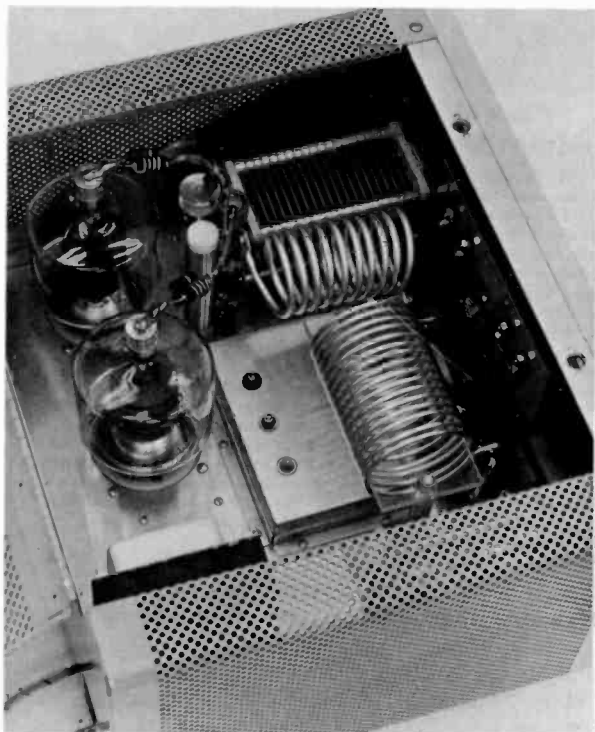

Figure 30
OBLIQUE VIEW OF
PLATE CIRCUIT

The Eimac HR-6 anode connectors are used on the 3-500Z tubes, with the parasitic suppressor mounted close to the connector. The plate leads are made of lengths of flexible copper braid. Both leads terminate at the plate-blocking capacitor which is mounted to a small bracket bolted to the stator terminal of the plate-tuning capacitor. At the far side of the tuning capacitor is the 1-pf ALC coupling capacitor, made of two 1-inch diameter copper discs, spaced about 1/4-inch apart. The upper disc is affixed to the stator terminal of the capacitor and the lower disc is supported by the feedthrough insulator mounted directly beneath it on the chassis deck.

the nominal value of r-f plate voltage swing is about 1800 volts. If the ratio of the capacitive divider is 1:200, then about 90 volts of peak pulse is applied to the diode. Under normal operation, the diode is biased to about +30 volts and ALC pulses of about one-half this value are normal. Thus, the r-f voltage at the diode should be not more than 45 volts or so, calling for a capacitance ratio of about 1:300. This ratio is well within the range of the mica compression capacitor used for C_8 .

The Metering Circuit—It is dangerous practice to place the plate-current meter in the B-plus lead to the amplifier unless the meter is suitably insulated from ground and isolated behind a protective panel so that the operator cannot accidentally receive a shock from the zero-adjustment fixture. If the meter is placed in the cathode return circuit, it will read the cathode current which is the sum of the grid and plate currents. A better idea is to place the plate meter in the B-minus lead between the cathode return circuit and the negative terminal of the power supply. The negative of the supply must thus be left "floating" above ground, or the meter will not read properly (figure 5). A protective resistor is placed across the meter circuit to ensure that the negative side of the power supply remains close to ground potential. A separate ground lead is then run between the chassis ground of the amplifier and that of the supply. Grid current is measured between grid and cathode return as shown in the simplified schematic, with the grid pins of the tubes directly connected to chassis ground.

The Cooling System—It is necessary to provide cooling air about the plate seal and filament seals of either the 3-400Z or 3-500Z tubes. Sufficient air is required to maintain the plate seal at a temperature below 225°C and the filament seals at a temperature below 200°C. Common practice calls for the use of special air-system sockets and chimneys, in conjunction with a centrifugal blower to maintain air flow requirements to meet these temperature limitations. Considerable difficulty with conventional cooling techniques has arisen, caused by the noise created by the blower motor and the movement of air through the cooling system. Extensive

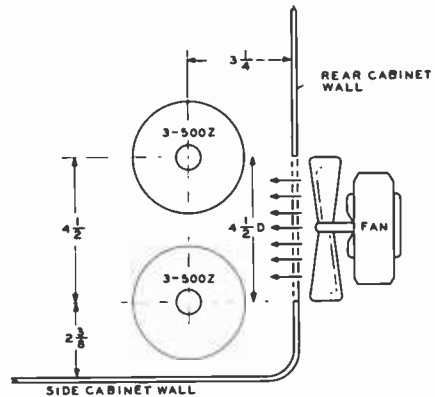

Figure 31
AIR-SYSTEM LAYOUT

The Ripley fan (Ripley Co., Inc., Middletown, Conn.) is bolted to the rear of the cabinet behind a 4 1/2-inch diameter hole, covered with 1/4-inch mesh wire screen. The air blast passes across the tube envelopes and the warm air is exhausted out the perforated top of the amplifier cabinet. The tube sockets are located with respect to the fan to permit maximum cooling air to envelop the tubes.

tests have shown that for c-w and SSB operation at the legal power limits (1-kW c-w input and 2-kW PEP voice input on SSB) either the 3-400Z or 3-500Z may be adequately cooled by a lateral air blast blown against the tube by a small rotary fan, properly spaced from the tube. A drawing of such an installation is shown in figure 31.

The new Johnson 122-275-1 ceramic tube socket is used, which permits a minimum amount of lateral pressure to be exerted on the glass base of the tube. The socket is mounted below the chassis deck about 1/16" to provide an air path around the base of the tube through which under-chassis air is drawn by convection. The rotary fan is mounted between the tubes, in line with the center of the glass envelope and blows cooling air across the envelope and plate caps. Under these conditions, maximum plate dissipation of about 350 watts per tube is achieved for the 3-400Z and 450 watts per tube for the 3-500Z. While maximum dissipation rating is not achieved with either tube, the allowable dissipation is sufficiently high so that the maximum amateur power input may be run in either case with adequate safety factor. If it is desired to operate the amplifier under steady-state

conditions (RTTY, for example), the power input will have to be reduced to about 850 watts in the case of the 3-500Z's or 750 watts for the 3-400Z's. The alternative is to install a forced-air cooling system to boost the plate dissipation capability to the maximum limit specified in the instruction sheet for the tube type in question. The air cooling system shown, however, is entirely adequate for c-w and SSB operation under normal operating conditions for extended periods of time.

The perforated metal cabinet provides maximum ventilation and, when the lid is closed, provides good r-f inclosure. In order to permit the air to be drawn into the bottom of the amplifier chassis, rubber "feet" are placed at each corner of the cabinet, raising it about one inch above the surface on which it sits. The top surface of the cabinet should be kept clear to permit the heat to freely escape from the amplifier when it is in use.

Amplifier Construction The over-all dimensions of the perforated, wraparound cabinet housing the amplifier are 16" wide, 8" high, and 13" deep. The amplifier is built on a shallow chassis bent from a single sheet of aluminum and measures 15 1/4" wide, 12 1/2" deep and has a 1" lip at the rear. Clearance under the chassis is 1 1/4" to the bottom of the cabinet. An oblique view of the chassis and cabinet, including the placement of the major components is shown in figure 30. The cooling fan is mounted to the rear of the cabinet and forces air against the two transmitting tubes through a 4" diameter hole cut in the rear panel of the cabinet. The hole is covered with a piece of wire mesh having 1/4" squares.

Placement of the major components may be seen in the photographs. Because of the small depth of the chassis, placement of the bandswitch and tuned cathode assembly is critical. The various cathode tuned circuits and bandchange switch are mounted in an inclosed box placed near the center of the chassis, in line with the main band change switch. The cathode inclosure box is made up of two small aluminum chassis (5" × 3 1/2" × 1") placed back to back, one atop and the other underneath

the chassis. The flanges of the chassis are cut off, and substitute flanges are attached to the outside of the chassis lips, permitting the two units to be bolted together, as shown. The various coils and bandswitch are mounted to the top chassis box, in line with the main switch and connected to it with a shaft coupler. The cathode coils and capacitors are assembled and mounted in a vertical position within the box, as shown in the photograph (figure 29). The cathode tank-coil assembly may be wired and the tuned circuits grid-dipped to the center of each amateur band before the chassis box is bolted to the corresponding cutout in the chassis.

The pi-network coil assembly is seen in the top view photographs. The 10-15-20 meter coil is wound of No. 8 solid copper wire. Ordinary plastic-covered house wire is used, the plastic coating stripped off before the coil is close wound on a suitable form. Once the winding is completed, the coil is spaced and the taps are soldered in place. Thin, 1/8" wide copper strap is used for the tap leads. Each lead is pretinned at the end and wrapped around the proper coil turn and soldered in place with a large iron. A good connection is important at this point as the r-f current flowing through the joint is high. Once the coil is cut to size, and the tap leads soldered in place, the coil end connections are trimmed to length and adjusted to the proper position. The coil lead to the tuning capacitor terminates in a copper soldering lug and the opposite end is flattened in a vise to make a glove fit with the proper 20-meter tap point on the bandswitch. Once all leads are properly trimmed, the coil is removed and silver plated.

The 40-80 meter coil is wound and tapped in the same fashion. Once completed, it is threaded on a strip of lucite or plastic material that has been grooved along both edges to fit the spaced winding of the coil. The grooves may be easily cut with a small triangular file. The lucite plate is supported by two plastic posts, cut to size and mounted to the chassis behind the bandswitch.

The plate parasitic suppressors for each tube are made of three composition resistors wired in parallel, with a small inductor wound around one resistor. The suppressors are placed immediately adjacent to the anode

connectors of each tube, and flexible leads made of copper braid are run from the suppressors to a common terminal of the plate coupling capacitor mounted atop the plate r-f choke.

The placement of the major components beneath the chassis is shown in figure 28. A T-shaped opening is cut in the forward area of the chassis to clear the plate band-switch, and an opening is cut in the center of the chassis for the cathode tank assembly. The tube sockets are mounted beneath the chassis by 6-32 hardware, with several washers placed on each mounting bolt beneath the chassis to lower the socket about 1/16 inch, providing additional air passage around the base seal of the tube. The grid pins are grounded to the adjacent socket bolts. The large filament choke is mounted from a phenolic terminal strip to the parallel-connected filament pins of the tubes. The mica coupling capacitors are placed in close position to the filament wiring and the ceramic feedthrough insulator mounted in the side wall of the input coil compartment.

At the side of the under-chassis area a small perforated circuit board supports the various components of the ALC circuit and the connecting lead to the 1-pf air capacitor mounted on the main tuning capacitor passes through a ceramic feedthrough insulator in the chassis deck.

The connection from the pi-network output capacitor to the coaxial receptacle mounted on the rear lip of the chassis is made via a short length of 50-ohm coaxial cable, the outer shield of the cable being grounded at both ends to nearby chassis points.

The filament transformer is mounted atop the chassis in a rear corner as seen in the photographs. The bottom area of the transformer is cleaned of paint so that the end bells make a good ground connection to the chassis to partially shield the windings from the r-f field atop the chassis. The end bell of the transformer nearest the tubes is painted white to reflect the infrared radiation emitted from the tubes, permitting the transformer to run much cooler than otherwise would be the case if the end bell was left black. The remainder of the transformer is left black so as to radiate the heat generated within the transformer.

The VOX relay and auxiliary transformer are mounted in a small shield box placed in front of the filament transformer. Sufficient room exists in this area so the box may be enlarged to also hold a rectifier and filter capacitor should it be desired to substitute a d-c relay for the a-c unit specified.

A shield plate measuring 6" X 2" is affixed to the rear of the meters to shield the movements from the intense r-f field surrounding the plate coils. The shield is held in position by the meter studs, each stud passing through a rubber grommet mounted in the shield plate. The plate is grounded in each corner by a short, direct lead to the meter mounting bolts.

Amplifier Adjustment Before the tubes are inserted in the amplifier, the main bandswitch should be set to the various bands and the plate tank assembly tuned for resonance on each band when the loading capacitor is set to about 2/3 maximum value. The approximate settings should be logged for future reference. The two

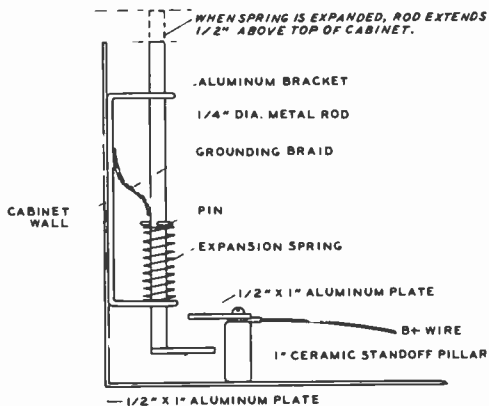

Figure 32
HOME-MADE HIGH-VOLTAGE
SAFETY SHORTING SWITCH

This switch is actuated when the cabinet lid is raised, shorting the B-plus lead to ground. The switch is made up of a short section of 1/4-inch shaft extension that is spring-loaded in the up position. Closing the lid forces the shaft down about 1/2 inch, breaking the short connection. When the lid of the cabinet is raised, the expansion spring pushes the rod upward, engaging the B-plus terminal. A grounding braid is used to make good ground connection to the shaft of the switch. The power supply should be fused or otherwise protected against the dead short.

Table 1.
Typical Operating Data, 3-500Z
R-F Linear Amplifier Service, Class-B
(one tube)

	1500	2000	2500
D-C Plate Voltage	1500	2000	2500
Zero signal Plate Current (ma)	65	95	130
Single Tone			
DC Plate Current (ma)	400	400	400
DC Grid Current (ma)	130	130	120
Two Tone			
DC Plate Current (ma)	260	270	280
DC Grid Current (ma)	80	80	70
PEP Useful Output Power (watts)	330	500	600
Resonant Load Impedance (ohms)	1600	2750	3450
Intermodulation Distortion Products (db)	-46	-38	-33

tubes are now inserted in their sockets and filament voltage applied to the amplifier. Voltage at the tube sockets should run between 4.8 and 5.1 volts, as measured with an accurate meter. The amplifier is now placed in the cabinet and the cooling fan connected so that it runs whenever the filament circuit is energized. An interlock switch atop the cabinet should be immediately wired so that it opens the high-voltage control relay in the power supply. In addition, a high-voltage shorting switch, such as shown in the illustration (figure 32), is suggested as an integral part of the amplifier, since lethal voltages are exposed when the lid of the cabinet is raised unless precautions are taken.

Typical operating voltages and currents for the 3-500Z tube are tabulated in Table 1. An operating plate potential of 2500 is recommended with an intermittent-service power supply capability of 800 milliamperes.

Initial adjustment is greatly facilitated with the aid of an SWR meter or other output indicating device. Plate voltage is applied to the amplifier and the resting plate current is noted. A small amount of grid drive is introduced into the amplifier and resonance established in the plate circuit. Drive and loading are gradually increased, holding a ratio of about 3:1 between indicated plate and grid current. In the case of the 3-500Zs, maximum indicated grid current should be about 240 ma for a plate current of 800 ma. This ratio should

be achieved with the minimum drive level and maximum antenna load level possible.

Under voice modulation, the plate current will kick to about 440 ma and grid current will kick to about 130 ma. For c-w operation at 2500 volts, plate loading and grid drive are decreased until 400 ma plate current and 125 ma grid current are noted on the meters. As with all grounded-grid amplifiers, grid drive should never be applied before plate voltage, or damage to the tubes may result.

28-7 The Triband KW-2 Linear Amplifier For 20, 15, and 10 Meters

Many radio amateurs concentrate their effort on the higher-frequency bands for DX operation. Others are located on small lots, or in apartments where the erection of a large low-frequency antenna for 40 and 80 meters is impractical. This linear amplifier is designed for the amateur whose principal interest lies in the 14- to 29.7-MHz portion of the spectrum. An amplifier built specially for this range can be made smaller, simpler, and more inexpensively than one covering the complete 3.5- to 29.7-MHz range.

The unit described in this section (figure 33) is a deluxe 2-kilowatt PEP class AB₂, grid-driven linear amplifier using a 4CX-1500B tube. This tube is a ceramic-and-metal, forced-air cooled tetrode with a maximum plate dissipation of 1500 watts. It is designed for exceptionally low intermodulation distortion in SSB service. Typically, at a plate potential of 2750 volts and a plate current of 730 ma (2-kW PEP input) the third-order intermodulation products are better than -40 decibels below one tone of a two-tone test signal. This is an order of magnitude better than the majority of SSB exciters on the amateur market. Under these conditions, the useful output power is better than 1100 watts, allowing for normal tank-circuit losses.

The Amplifier Circuit The 4CX1500B is used in a passive-grid circuit, of the type shown earlier in this chapter (figure 4). While the grid-drive requirement of the 4CX1500B is only about

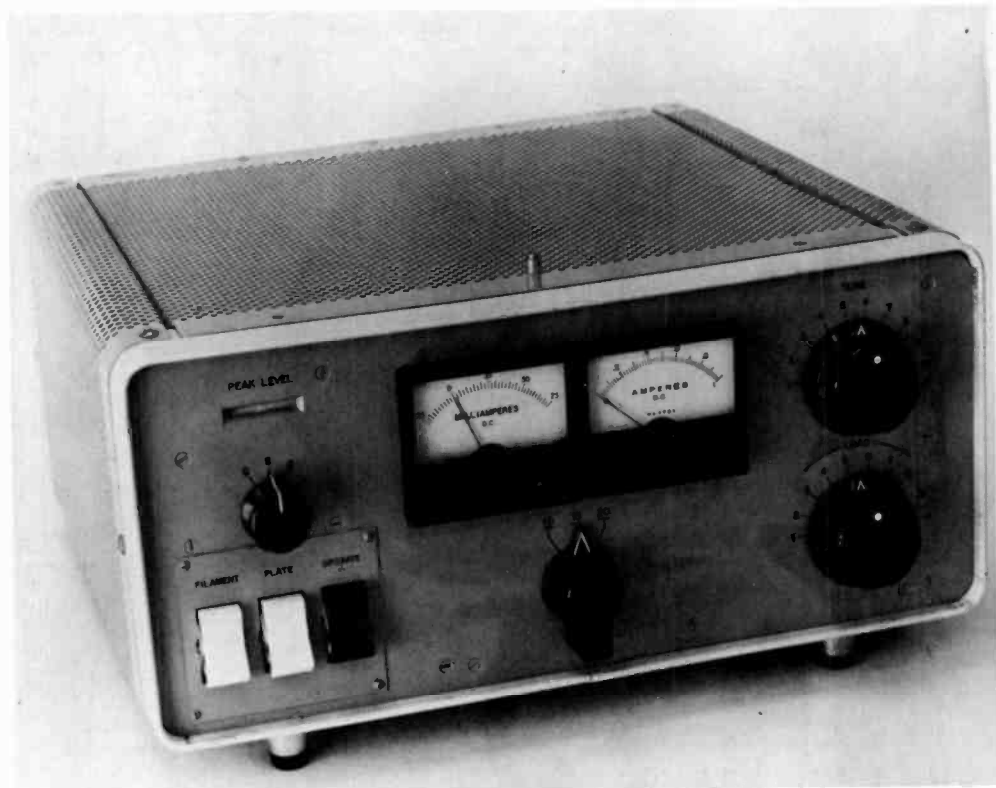

Figure 33

THE KW-2 TRIBAND LINEAR AMPLIFIER

Designed for 2-kW PEP operation on the 20-, 15-, and 10- meter amateur bands, the KW-2 features an Eimac 4CX1500B tetrode in a passive-grid circuit. A pi-L output tank circuit provides maximum harmonic attenuation.

The amplifier is contained within a standard perforated metal cabinet. The multimeter (left) and plate-current meter (right) are centered on the panel, with the tuning and loading controls at the right. The bandswitch is centered below the meters. At the left of the panel are the peak-level tuning tube, mounted in a horizontal position behind a panel cutout; the multimeter selector switch, and the three control switches.

The panel is spray-painted and decals are applied before a final coat of clear Krylon is sprayed on.

1.5 watts PEP, the output of modern SSB excitors is usually of the order of 100 to 200 watts PEP. A low-impedance passive input circuit will provide the proper load for the exciter and permit the excess drive power to be safely dissipated (figure 34). In this case, the input circuit is composed of four 200-ohm, 10-watt "noninductive" resistors connected in parallel to provide 50 ohms at a total dissipation of 40 watts. This is sufficient capacity to handle over 100 watts PEP of drive signal under voice conditions. The wirewound "noninductive" resistors are chosen in preference to carbon

or composition resistors because the input impedance of the tube presents a capacitive reactance, and the slight inductive reactance of the resistors tends to provide a more uniform load for the SSB exciter across the operating range of the amplifier.

Grid bias is applied to the 4CX1500B in shunt with the passive grid resistor and provisions are incorporated for monitoring grid current, as well as for setting the resting plate current (R_1 , adjust bias potentiometer).

A pi-L network is used in the output circuit of the amplifier since it provides nearly 15 decibels more harmonic attenuation than

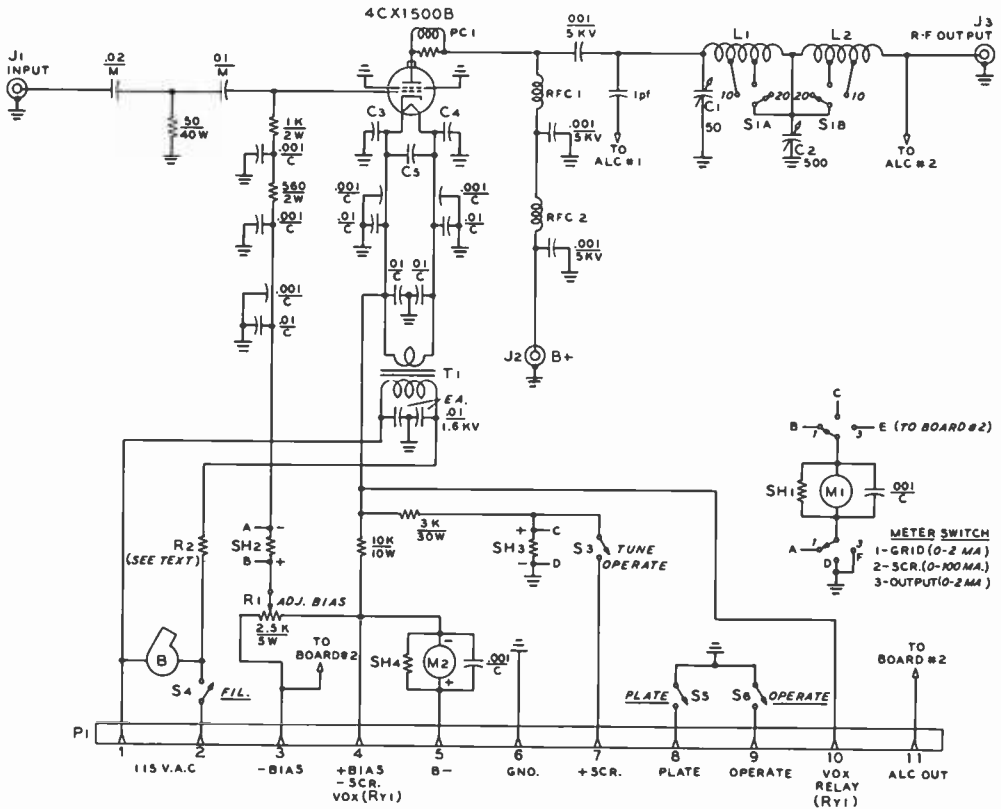

Figure 34
SCHEMATIC, TRIBAND LINEAR AMPLIFIER

C_1 —50 pf, 4.5 kV. Johnson 154-12

C_2 —500 pf, 2 kV. Johnson 154-3

C_3 , C_4 , C_5 —0.01- μ fd mica capacitor in parallel with .001- μ fd silver mica capacitor

L_1 —10 turns, 1 7/8" diam., 4" long of 1/4-inch copper tubing (2.5 μ H). 15-meter tap: 7 3/4 active turns (1.8 μ H). 10-meter tap: 5 1/2 active turns (1.2 μ H)

L_2 —12 turns #10, 1" diam., 2 1/4" long (1.6 μ H). 15-meter tap: 9 1/4 active turns (1.2 μ H). 10-meter tap: 6 1/4 active turns (0.8 μ H)

S_{1A} , R —2-pole, 6-position ceramic switch. Radio Switch Corp. Model 86-B

RFC_1 —72 turns #20 e., 3/4" diam., 2 3/4" long. 26 t.p.i. Series resonant at 25 MHz when mounted in place

RFC_2 —2 μ H, 700 ma. National R-60 or Ohmite Z-144

T_1 —6.3 volts at 10 amperes. UTC H-134. Adjust 20-watt series primary resistor to provide 6.0 volts under load

PC_1 —47-ohm, 2-watt composition resistor shorted across 1 1/4" of plate strap

J_1 —Receptacle, UG-290/U, type BNC
 J_2 —Receptacle, high-voltage, UG-496/U, type HN

J_3 —Receptacle, UG-58A/U, type N

SH_1 —2-milliampere shunt (resistance equal to that of meter movement)

SH_2 , SH_3 —100 ohms, 2 watts

SH_4 —100-ma shunt

Blower—Ripley 81 (left hand), 2 3/4" impeller, 3100 rpm. 22 c.f.m. at static pressure of 0.4" water

Socket—Eimac Y-149A

Chimney—Eimac SK-816

does the conventional pi network. A design Q of 15 is used and since the low-frequency bands are not included in the design, only two small, self-supporting air-wound coils are required. In addition, the size of the pi-L network loading capacitor (C_2) is considerably smaller than a capacitor necessary for all-band operation.

Incorporated in the amplifier is an ALC circuit and an electron tuning tube, such as used in the amplifier described in section 5 of this chapter. The reader is referred to that section for a description of the electron tuning circuit.

In order to achieve maximum shielding and good amplifier stability, the screen ele-

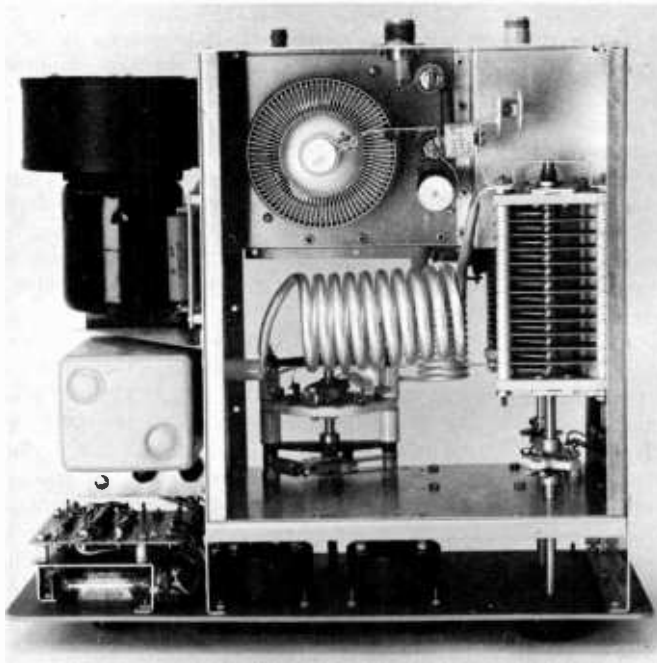

Figure 35
TOP VIEW OF KW-2
AMPLIFIER

The 4CX1500B is mounted at the rear of the main amplifier inclosure on a separate subchassis. To the right of the tube are the plate r-f chokes and bypass capacitors. The ALC coupling capacitor is directly behind the main plate tuning capacitor.

At the center of the inclosure is the pi portion of the tank coil, with the L section mounted at right angles below it, on a level with the ceramic bandswitch. Outside the inclosure, at the left, are the blower, filament transformer, and various ALC components, which are mounted to a phenolic board at the front panel. A small board atop the blower supports the 10-watt wirewound resistors. The 6FG6 electron tuning tube is mounted flush with the panel by means of a small aluminum bracket which also supports one end of the phenolic component board. The ALC coupling (approx. 1 pf) is composed of two 1" diameter copper discs, spaced about 1/4-inch apart. One disc is mounted to the stud of the plate-blocking capacitor, and the other is supported on a copper strap bolted to a ceramic feedthrough capacitor mounted on the subchassis.

ment of the tetrode tube is run at r-f ground potential. Screen voltage is applied to the tube by grounding the positive terminal of

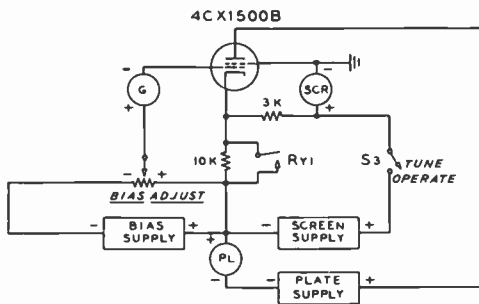

Figure 36
MAIN POWER-CIRCUIT WIRING

The screen of the 4CX1500B is operated at r-f ground-potential and screen and bias supplies are operated below chassis ground by the amount of the screen voltage. All supplies return to a common B-minus point at the cathode of the tube. To drop standby plate current, the VOX relay introduces a 10K cathode-bias resistor, which is shorted out on closure of the relay. The screen circuit retains a d-c path to the cathode via the 3K resistor, thus permitting the screen voltage to be removed for tuneup purposes.

the screen supply and "floating" the screen and bias supplies below ground, as shown in figure 36. A special socket is used for the 4CX1500B which provides a low-inductance screen to ground path.

A multipurpose meter (M₁) measures grid, screen, and relative r-f output of the amplifier tube and a separate meter (M₂) measures the plate current.

Amplifier screen voltage is removed for tuneup by means of tune-operate switch S₃. The positive lead of the screen power supply is broken, however, the screen-to-cathode path is maintained by the 3K bleeder resistor. Inclusion of this resistor is imperative, since the screen voltage must be maintained positive for any values of screen current that may be encountered. As with most high-gain tetrode tubes, the 4CX1500B exhibits negative screen current under certain operating conditions (notably, when plate loading is insufficient). Dangerously high values of plate current may flow if the screen voltage rises under conditions of low or negative screen current. Screen-circuit control is accomplished by the 3K bleeder resistor

which stabilizes the screen voltage under any operating conditions, even when the screen lead to the supply is broken and external screen voltage is zero.

The rated heater voltage for the 4CX-1500B is 6.0 volts and the voltage, as measured at the tube socket, should be maintained between 5.8 and 6.0 volts to achieve maximum tube life. In no case should the voltage be allowed to exceed 5-percent above or below the rated value. The cathode and one side of the heater are connected internally within the tube.

Amplifier Assembly The amplifier is built on a special open framework that fits within a standard perforated metal cabinet. The r-f components are contained within an inclosure measuring $9\frac{1}{4}$ " wide, $5\frac{7}{8}$ " high and $12\frac{1}{4}$ " deep. The top and bottom of the box are covered with perforated aluminum stock for proper ventilation. The 4CX1500B socket is placed off-center on a small aluminum chassis (figure 35) measuring $6\frac{1}{4}$ " long, $4\frac{1}{2}$ " wide and $1\frac{3}{4}$ " high. The center of the socket falls on the center line of the amplifier panel and is about $2\frac{1}{2}$ " from the rear of the inclosure. The forward area of the inclosure is clear, and the amplifier plate tank coil, bandswitch, and plate-tuning capacitor are placed in this area. The tuning and loading capacitors are affixed at the rear to an L-shaped bracket that fills the space between the tube-socket inclosure and the wall of the main inclosure.

A space about 2" deep is left between the r-f inclosure and the main amplifier panel. The two panel-mounted meters recess into this space, and the main amplifier tuning control shafts pass through this area to the control dials.

To the left, the blower, filament transformer, and main terminal strip are mounted to the wall of the inclosure. A rectangular hole is cut in the side of the tube compartment to accommodate the mouth of the blower, which is mounted to the box with short sections of aluminum angle stock. The filament transformer is supported on a small (shelf, which also holds the *adjust bias* potentiometer (R_1) and the *adjust ALC* potentiometer (R_2). To the front of the shelf is a phenolic terminal board, supported by the front panel, which holds the various compon-

ents for the electron tuning indicator. The 6FG6 tube is mounted behind a panel cut-out on a small aluminum bracket (figure 35).

The pi-portion of the plate tank coil (L_1) is self-supporting between the stator terminal of tuning capacitor C_1 and a one-inch ceramic standoff insulator fastened to the side wall of the inclosure near the bandswitch. The L-section coil (L_2) is placed at right angles to the larger coil and is positioned below it, being supported by one terminal of the bandswitch and a short length of RG-8/U coaxial line that reaches from the coil to the antenna receptacle (J_3) on the rear panel of the assembly.

The ALC and 6FG6 electron tuning tube components are mounted to two phenolic boards (figure 37). Board No. 1 is mounted vertically inside the r-f inclosure, between the loading capacitor (C_2) and the antenna receptacle. Four shielded leads run from this board toward the front of the amplifier and pass out of the box via .001- μ fd feedthrough capacitors mounted in the front wall of the inclosure. Each feedthrough capacitor is double bypassed with a .01- μ fd disc ceramic capacitor within the box. Once outside, the four leads again run through shielded wire to board No. 2 placed behind the left side of the front panel (figure 35).

The 200-ohm noninductive resistors which make up the passive input circuit are mounted within the tube-socket chassis (figure 38). The filament bypass capacitors (C_3 , C_4 , C_5) are composed of a .01- μ fd, 600-volt mica capacitor placed in parallel with a .001- μ fd silver-mica capacitor. Each filament lug is bypassed with this combination. In addition, .001- μ fd ceramic feedthrough capacitors are used to conduct the filament leads outside the chassis, and each feedthrough capacitor is further bypassed with a .01- μ fd ceramic capacitor on the inside of the chassis. Additional disc-ceramic capacitors are placed at the terminals of the filament transformer, as shown in the schematic diagram.

The multimeter (M_1) has an off-center movement and the scale is calibrated -25 to +75 milliamperes. Negative screen current may be measured by this modified meter. Unless means are at hand to make this modification, a zero-center -50 to +50

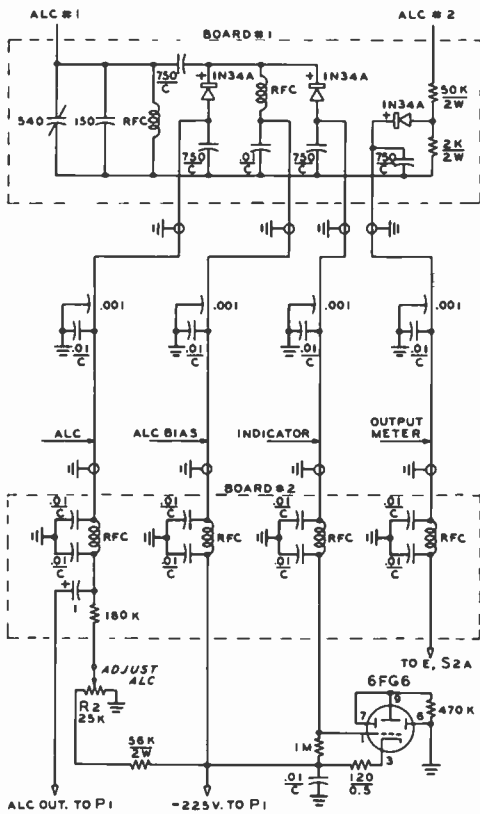

Figure 37
AUXILIARY POWER WIRING

Circuit board #1 (top) is mounted near output receptacle (J₁) of amplifier and holds the 540-pf ALC adjustment capacitor. Circuit board #2 (bottom) is mounted behind the 6FG6 electron tuning tube. ALC and electron-tube range are set by adjustment of ALC capacitor. Range of ALC control is set by adjust ALC potentiometer (R₂). Electron-eye anodes operate at ground potential with cathode -225 volts below ground. Filament voltage for 6FG6 may be taken from transformer T₁. All r-f chokes are 2.5 mH (National R-100), or equivalent.

meter having a one milliamperer movement may be used (see parts list).

Amplifier Adjustment A power supply delivering the following voltages is required for amplifier operation: 2700 to 3000 volts at an IVS current rating of 800 milliamperes, 225 volts at a CCS current rating of 100 milliamperes, and -50 volts at 25 milliamperes. Three separate supplies may be used, connected to the amplifier

in the manner shown in figure 36. The control circuits should be arranged so that bias and filament supply come on before the screen and plate supply, and a time delay relay providing a waiting period of 3 minutes is recommended.

For preliminary tuneup, the filament of the 4CX1500B should be energized for about 5 minutes with the bias supply adjusted for maximum bias. During this time, the plate-tank circuit should be adjusted, using a grid-dip oscillator to set the main tuning capacitor. The loading capacitor may be set at half-scale. *Tune-operate* switch S₃ should be set in the *operate* position. The VOX relay should be closed.

Operating voltages are applied and the bias voltage adjusted for a resting plate current of 300 milliamperes. Switch S₃ is now set to the *tune* position and the multimeter switch set to the *grid* position. A small amount of drive power is applied until an indication of plate current is apparent and the plate-tank capacitor tuned for resonance. The operate switch is now reset to the *operate* position and grid drive advanced until about one-half milliamperer of grid current is noted. Plate loading is increased until about 700 milliamperes are indicated on the plate meter. Grid drive and loading are adjusted until the operating data outlined in Table 2 are achieved.

With carrier removed and voice modulation applied, the plate current will rise to about 400 milliamperes maximum, and screen current will peak at about -8 milliamperes. Grid current should be limited to about 0.03 milliamperer.

When the VOX relay opens, resting plate current will drop to only a few milliamperes,

D-c plate voltage	2750	2900 volts
D-c screen voltage	225	225 volts
D-c grid voltage	-34	-34 volts
Zero-signal d-c plate current	300	300 ma
Single-tone d-c plate current	755	710 ma
Two-tone d-c plate current	555	542 ma
Single-tone d-c screen current	-14	-15 ma
Two-tone d-c screen current	-11	-11 ma
Single-tone d-c grid current	0.95	0.53 ma
Two-tone d-c grid current	0.20	0.06 ma
Peak r-f grid voltage	45	41 volts
Driving power	1.5	1.5 watts
Resonant load impedance	1900	2200 ohms
Useful output power	1100	1100 watts

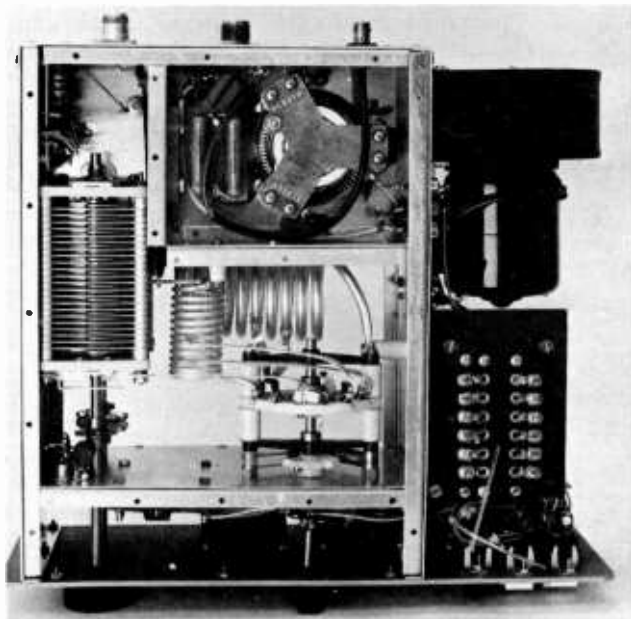

Figure 38
UNDER-CHASSIS VIEW OF
KW-2 AMPLIFIER

The bottom of the socket chassis has been removed to show placement of major components within the chassis. The squirrel-cage blower mounts to the side of the inclosure, with the air blast going directly into the small chassis. The air is exhausted through the tube socket and out the anode of the 4CX1500B. At the right is the double terminal strip to which the main power cable is attached. The arrangement of the L-section coil is visible at the center of the main inclosure.

as sufficient resistor bias is added to produce near-cutoff conditions.

Operation of the amplifier should be monitored with an oscilloscope to make sure that "flattopping" does not occur at maximum input level. When the proper maximum voice level has been established, the mica compression capacitor on board No. 1 may be adjusted to allow the tuning indicator to completely close at this signal level.

28-8 A Two-Stage High-Gain Amplifier Using The 3-1000Z

This sturdy amplifier (figure 39) is designed to operate at the 2-kW PEP input level when driven by an SSB signal of not more than 500 milliwatts PEP level. Amplifier gain is better than 33 decibels, and operation is stable under all normal conditions. The amplifier is designed for single-band operation at any frequency between 3.5 MHz and 30 MHz, and specific data is included for operation on any one of the amateur bands between 80 and 10 meters. Tank circuits are designed for a coverage of 500 kHz at the low end of the range of

operation, and for 1.5-MHz coverage at the high end of the range. Used for heavy-duty service, the amplifier is capable of key-down (RTTY) service at the 2-kW power input level. Choice of rugged components and an efficient cooling system assure reliable, trouble-free, around-the-clock service.

The amplifier consists of a two-stage circuit, employing a 4CX250B ceramic tetrode operating class AB₁ to drive a 3-1000Z grounded-grid, class-B linear stage. For those amateurs having an SSB exciter capable of about 70 watts PEP output, the driver stage may be eliminated, and the 3-1000Z stage can be driven directly by the exciter. This may be accomplished by breaking the interconnecting coaxial cable between the stages at point X (figure 40). The 4CX250B stage may then be omitted, or a switch installed at this point to allow the amplifier to be used at two widely different drive levels.

When operated under normal conditions, the third-order intermodulation distortion figure of the two-stage amplifier is better than -33 decibels below one tone of a two-tone test signal.

Amplifier Circuitry The circuit of the two-stage, high-gain linear amplifier is shown in figures 40 and 43. The

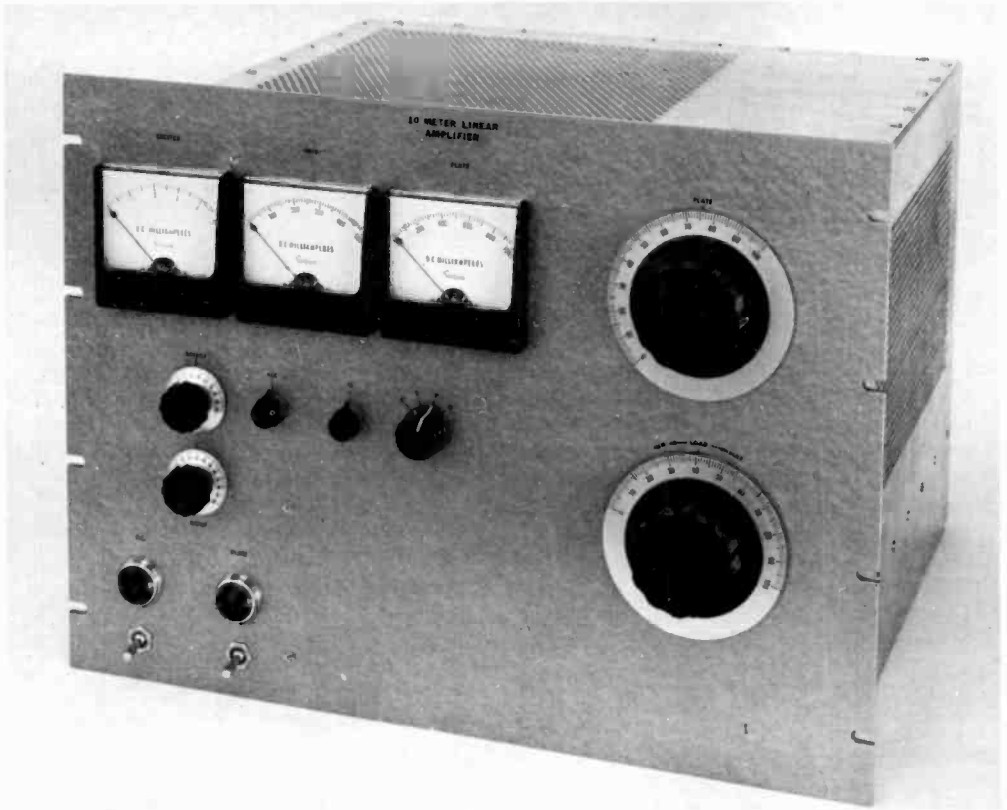

Figure 39

TWO-STAGE LINEAR AMPLIFIER WITH 3-1000Z

This rugged, high-gain linear amplifier is designed for continuous-service operation at the 2-kw power level. Less than 1-watt PEP drive is required for full input. The amplifier is designed for single-band operation on any range of frequencies between 3.5 and 30MHz.

The amplifier uses two tubes; a 4CX250B tetrode driver operating class AB₁ and a 3-1000Z high- μ triode in grounded-grid circuitry. For use with exciters having a power output of 100 watts PEP or so, the driver stage may be omitted. The amplifier is designed for mounting in a standard 19" cabinet. The top of the shielded inclosure is removable, with top, sides and back being perforated to allow proper circulation of air within the amplifier.

Panel meters are (l. to r.): Multimeter M₁, grid-current meter M₂, and plate-current meter M₃. In a vertical position below the left-hand meter are the input and output tuning controls for the driver stage, with the ALC Adjust, Adjust output, and meter-switch knobs to the right. Primary filament and plate circuit switches and pilot lamps are at the bottom of the panel. At the right are the plate-tuning control (top) and antenna-loading control (bottom). The panel is painted a hammertone gray and lettering is placed in position, then panel is given a spray coat of clear Krylon to protect the finish.

3-1000Z high- μ triode is operated in cathode-driven, grounded-grid service in the zero-bias mode. A pi-L network (C₅, C₆, L₄, L₅) is used in the plate circuit to achieve maximum harmonic suppression. The network is designed to match a 50-ohm load having a maximum SWR figure of 3/1, or less. To restrict overload and "flattopping," a portion of the instantaneous r-f plate voltage is sampled and rectified for use as ALC control, and applied to the exciter.

The 3-1000Z is coupled to the driver by a short length of coaxial line. The driver, a 4CX250B tetrode, is bridge neutralized for proper stability and the grid circuit is loaded by a resistor (R₁) to establish the system drive level at about 1.5 watt PEP. Without the resistor, the typical drive level is about 500 milliwatts PEP for full output of the two-stage amplifier at 3.8 MHz.

The 4CX250B has a relatively high-Q plate-tank circuit that is designed to work

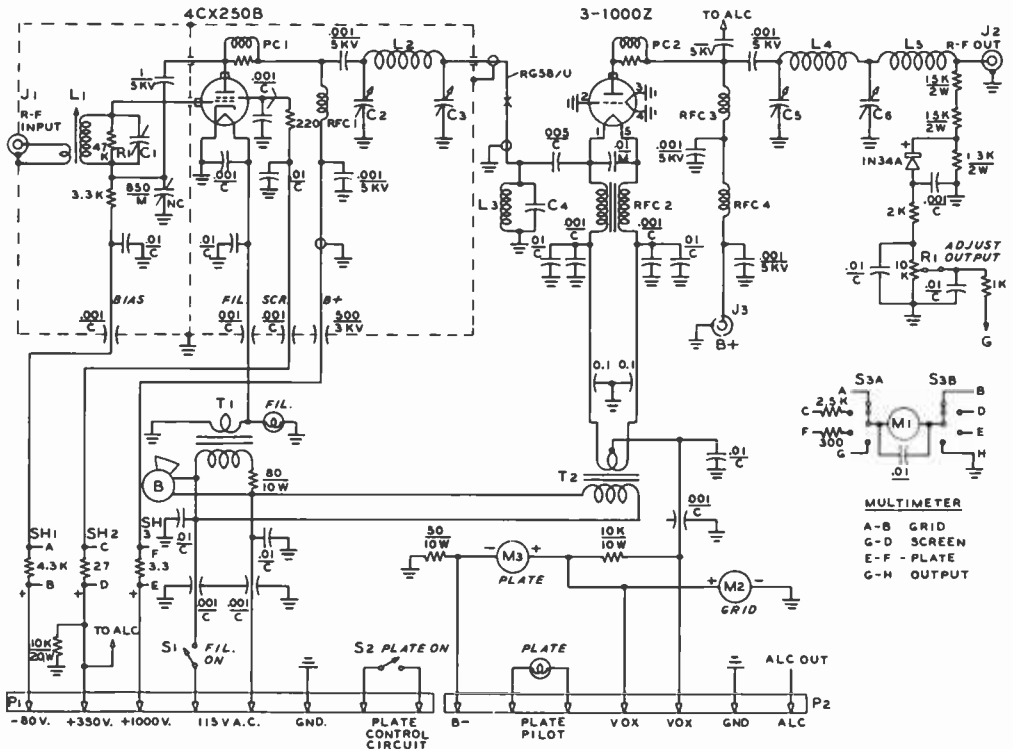

Figure 40

SCHEMATIC OF TWO-STAGE HIGH-GAIN AMPLIFIER

Note: See tables 4 and 5 for coil and capacitor data.

- J₁—UG-290/U, type BNC connector
- J₂—UG-58A/U, type N connector
- J₃—UG-496B/U, type HN connector
- PC₁—3 turns #14, spaced around a 47-ohm, 2-watt composition resistor
- PC₂—(80-40 meters): 7 turns #12, 3/4" diam., around 50-ohm, 5-watt resistor. Ohmite P-300 (20-15 meters): 3 turns #12, as above. Ohmite P-300 with turns removed (10 meters): 2 turns #12, as above. Ohmite P-300 with turns removed
- RFC₁—(80 meters): 1-mH, 600-ma. National R-154 (40-10 meters): 44-μH, 600-ma. Ohmite Z-14
- RFC₂—B&W FC-30A. Home-made substitute: 14 bifilar turns #10 e. wire on ferrite core, 1/2" diam., 3" long. (Indiana General CF-503 core. Newark Electronics catalog no. 59F-1521). Notch core with file and snap to break to length.
- RFC₃—(80-20 meters): 200 μH, 800 ma. B&W 800. Home-made substitute: 180 turns #20, 3/4-

- inch diam., spaced 4 1/2" long, 40 t.p.j. Series resonant at 24 MHz. (15 meters): 130 turns, as above, 3 1/4" long. Series resonant at 28 MHz. (Remove turns from B&W 800) (10 meters): 70 turns # 16, 3/4-inch diam., 3" long. Series resonant at 40 MHz.
- RFC₄—2 μH. Ohmite Z-144
- T₁—6.3 volts, 3 amps. Chicago-Stancor P-6466
- T₂—7.5 volts, 21 amps. Chicago-Stancor P-6457
- N₁—850-pf, mica compression capacitor. ARCO 306M
- Blower—20 cu ft./min. Dayton 1C-180 or Ripley LR-81
- SH₁, SH₂, SH₃—Meter shunts. Wind resistance wire around 47K, 1-watt resistor to provide proper meter ranges, as shown above
- M₁—0-1 d-c milliammeter, Simpson 1327
- M₂—0-500 d-c milliammeter, Simpson 1327
- M₃—0-1000 d-c milliammeter, Simpson 1327
- Socket for 4CX250B—SK-600
- Chimney for 4CX250B—SK-606
- Socket for 3-1000Z—SK-510
- Chimney for 3-1000Z—SK-516

into a 50-ohm load. To combine high gain with maximum stability, the driver grid and plate circuits are carefully shielded from each other. In addition, the chassis is arranged

to isolate the input and output circuits with-in the enclosure by the use of multiple bypass capacitors and proper shielding of the power and metering leads. The majority of small

Figure 41

TOP VIEW OF HEAVY-DUTY AMPLIFIER

An interior view of the 40-meter amplifier. Inclosed 4CX250B stage is at the side of the assembly, with centrifugal blower directly behind it. Pi-L plate-circuit components are at the left, with 3-1000Z tube and chimney on center line of chassis.

On the rear apron of the inclosure are (l. to r.): antenna, high-voltage, power, and input receptacles. The last three connectors are inclosed in a small aluminum box beneath the chassis to shield the leads from the r-f circuitry. Layout of major components is identical for all amplifiers.

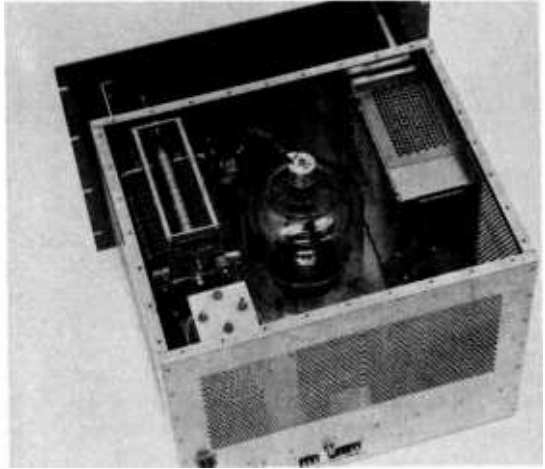

components are removed from the r-f inclosure and are mounted on phenolic terminal boards between the inclosure and the amplifier panel.

Amplifier operation is monitored by three panel meters. Meter M_1 is a multimeter which reads grid, screen, or plate current of the 4CX250B, in addition to monitoring relative power output of the amplifier. Meter M_2 measures grid current of the 3-1000Z, and meter M_3 measures plate current in the B-minus return lead to the power supply.

Both the 4CX250B and the 3-1000Z require forced-air cooling at 25 c.f.m. A single centrifugal blower provides this air flow, at a back pressure of about 0.4 inch of water.

Amplifier Construction Proper interstage shielding in this amplifier contributes to the high degree of stability. The unit is built within an aluminum inclosure measuring 18" wide, 12" high, and 15" deep. Sides and back of the inclosure are perforated

Figure 42
**UNDER-CHASSIS VIEW OF
10-METER AMPLIFIER**

The 3-1000Z socket is near chassis center, with the filament choke directly below it, and the cathode tuned circuit at one side. To the right of the socket is the electrical conduit and shield box for the power receptacles and wiring. Air inlet from the blower is seen at lower left, with exit hole for passing cooling air to the 4CX250B buffer stage at the upper left. The air opening is covered with screening. Filament transformer for the 4CX250B is at extreme left, with primary-circuit terminal strip adjacent to it. The shaft of 4CX250B loading capacitor projects through the bottom of the chassis directly above the transformer. Filament "Hypass" capacitors for the 3-1000Z are at the right of the filament choke, and the short coaxial lead for high voltage passes toward the back of the amplifier at the right side. Power wiring to the panel is extra length so that the panel may be removed for test purposes.

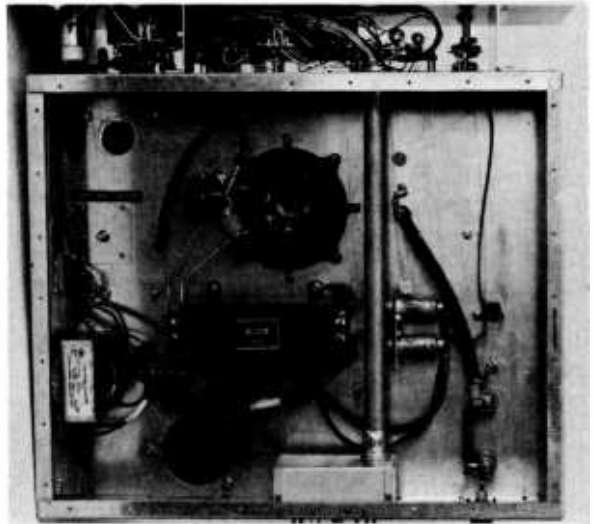



Figure 45

INTERIOR VIEW OF DRIVER STAGE

The 4CX250B driver is mounted within a separate compartment atop the main amplifier chassis. The sides and top panel of the compartment are removable. The lower enclosure holds the driver grid circuit components, with the variable compression mica neutralizing capacitor in the foreground. The pi-network plate circuit of the 4CX250B is at the right.

sage through the socket and anode cooler of the 4CX250B.

The 3-1000Z cathode tuned circuit and filament choke are mounted under the amplifier deck, as is the 4CX250B filament transformer. Power and metering connectors are placed on the rear apron of the chassis and the various leads pass through the under-chassis area to the front-panel controls and components via a short length of 1/2-inch diameter electrical conduit pipe, grounded at both ends. A solid bottom plate completes the r-f shielding and also pressurizes the under-chassis area. The small joints, seams and holes in the chassis are filled with caulking compound to make the plenum chamber air tight.

The complete amplifier assembly is supported from the front panel by means of two U-channels made of aluminum. The intervening 2" space holds the circuit boards

for various small components; and the panel meters, switches, and controls recess into this area.

The pi-network loading capacitor for the driver stage (C_3) may be set for a 50-ohm load and forgotten. Accordingly, it is not brought out to the panel, but is mounted in a vertical position, with the shaft projecting into the under-chassis area (figure 42). It may be adjusted, if desired, by placing an adjustment hole in the bottom chassis plate, and covering the hole with a snap button when it is not in use. The 4CX250B neutralizing capacitor (NC, figure 45) is adjustable through a hole drilled in the side panel of the subassembly. This adjustment hole, too, is covered when not in use to maintain the proper pressurized air system.

Amplifier Tuning and Adjustment The 4CX250B driver stage should be adjusted separately on the bench before

it is placed within the amplifier. Temporary cooling air may be applied to the unit, and it can be operated into a dummy load. The 4CX250B requires 1000 volts at 220 ma for the plate, 350 volts (regulated) at 50 ma for the screen and -80 volts (adjustable) at 10 ma for the bias supply. Bias, plate, and screen voltages to the 4CX250B are applied in that order. Bias is adjusted for a resting plate current of 100 ma.

Before voltages are applied, the 4CX250B should be neutralized according to the procedures outlined in Chapter 11. Operating voltages are then applied through the metering circuits of the amplifier, making sure the 10K screen bleeder resistor is in the circuit. When properly loaded and driven, the plate current of the 4CX250B will run about 200 to 250 ma, screen current about 15 ma or less, and grid current should be less than one division on the 0-1 ma meter range. Proper neutralization is indicated by maximum power output, maximum screen current and minimum plate current all coinciding at one setting of tuning capacitor C_2 . Once the amplifier has been properly adjusted, it may be permanently placed in the amplifier compartment and wired in place. Power output should be 100 to 120 watts, single tone with less than 1.5 watts driving power.

Table 4.
4CX250B Driver-Circuit Data

Band	L_1	C_1	L_2	C_2	C_3
80	(11 μ H) J. W. Miller 43A105CBI, $\frac{1}{2}$ " diam. Primary = 15t #22 e.	200 pf	(13 μ H) 28 turns # 12, $1\frac{1}{4}$ " diam., 2" long	200 pf 1.6 kV	1500 pf
40	(6.5 μ H) J. W. Miller 42A68CBI, $\frac{1}{2}$ " diam. Primary = 10t #22 e.	100 pf	(7.5 μ H) 14 turns # 12, 1" diam., 2" long	100 pf 2 kV	1000 pf
20	(3.3 μ H) J. W. Miller 42A336CBI, $\frac{1}{2}$ " diam Primary = 5t #22 e.	25 pf	(3.7 μ H) 16 turns # 12, 1" diam., $1\frac{1}{2}$ " long	75 pf 2 kV	600 pf
15	(2.2 μ H) J. W. Miller 42A226CBI, $\frac{1}{2}$ " diam. Primary = 4t # 22 e.	15 pf	(2.0 μ H) 6 turns # 10, 2" diam., 3" long	50 pf 2 kV	300 pf
10	(1.2 μ H) 8 turns # 18, $\frac{5}{8}$ " diam. $\frac{1}{2}$ " long. Pri. = 4 turns # 18, $\frac{5}{8}$ " diam., $\frac{1}{2}$ " long	15 pf	(1.5 μ H) 6 turns #10, $1\frac{1}{4}$ " diam., $1\frac{1}{8}$ " long	35 pf 2 Kv	200 pf

Voltage requirements for the 3-1000Z are: 3000 volts at 670 ma (SSB) or 2000 volts at 500 ma (c.w.). For tune-up purposes, the VOX terminals on power plug P₂ should be shorted together. Plate voltage is applied, with the amplifier first being adjusted for c-w operation. Using a dummy load, excitation is slowly raised until the

3-1000Z draws 500 ma plate current at resonance at a grid current of about 200 ma. Excitation and antenna loading are interlocking, and are varied until this ratio of currents is achieved. The output circuit of the 4CX250B stage is re-resonated (and perhaps loading adjusted slightly) until the proper drive level is reached at the desired

Table 5. 3-1000Z Circuit Data

Band	L_2	C_1	L_3	C_2	L_4	C_3
80	12 turns #10, $\frac{3}{4}$ " diam., $1\frac{1}{2}$ " long (1.25 μ H)	1600 pf XMTG. MICA	(9 μ H) 14 turns #6, $3\frac{1}{2}$ " diam., 5" long	500 pf 3.5 kV Johnson 153-6	(6.5 μ H) 20 turns #12, $1\frac{1}{4}$ " diam., 2" long	1500 pf
40	4 turns #10, $1\frac{1}{8}$ " diam., $1\frac{1}{2}$ " long (0.6 μ H)	1000 pf XMTG. MICA	(4.5 μ H) 8 turns #6, $3\frac{1}{2}$ " diam., $3\frac{1}{2}$ " long	150 pf 4.5kV Johnson 153-12	(3.2 μ H) 11 turns, #12, $1\frac{1}{4}$ " diam., 1" long	1000 pf
20	4 turns #10, $1\frac{1}{8}$ " diam., $1\frac{1}{2}$ " long (0.3 μ H)	400 pf XMTG. MICA	(2.2 μ H, 10 turns $\frac{1}{4}$ " tubing, $1\frac{7}{8}$ " diam., $4\frac{1}{4}$ " long	100 pf 7 kV Johnson 153-14	(1.5 μ H) 15 turns #12, $\frac{3}{4}$ " diam., 2" long	500 pf
15	3 turns #10, 1" diam., 1" long (0.2 μ H)	250 pf XMTG. MICA	(1.3 μ H) 6 turns $\frac{3}{8}$ " tubing, 2" diam., 4" long	75 pf 4.5 kV Johnson 154-13	(0.9 μ H) 10 turns #10, $\frac{1}{2}$ " diam., $1\frac{1}{2}$ " long	250 pf
10	4 turns #12, $\frac{1}{2}$ " diam., $\frac{3}{4}$ " long (0.15 μ H)	200 pf XMTG. MICA	(1.2 μ H) 6 turns $\frac{3}{8}$ " tubing, $1\frac{1}{2}$ " diam., 3" long	35 pf 4.5 kV Johnson 154-11	(0.6 μ H) $4\frac{1}{2}$ turns #10, $\frac{5}{8}$ " diam., $1\frac{1}{8}$ " long	250 pf

input to the 3-1000Z. Power output of the amplifier will be 650 watts, or better at 1-kW input.

In order to go from a one-kilowatt state to a 2-kW PEP state under the same load conditions, it is necessary to raise the plate voltage of the tube to 3000. At this plate potential, resting plate current should be about 220 ma when the VOX terminals are shorted. When the terminals are open, the bias provided by the 10K cathode resistor will drop the plate current to a few milliamperes. At the 3-kV potential, then, excitation is gradually raised to achieve a plate current of 665 ma at a grid current of 180 to 200 ma. Tuning adjustments need not be changed from the c-w condition.

If it is found that grid current to the 3-1000Z is too low when plate current reaches 665 ma at resonance, it is an indication that antenna loading is too heavy for the degree of grid drive. Conversely, if grid current is too high, it is an indication that excitation is too high for the amount of antenna loading. A proper balance of drive level and antenna loading will permit the proper ratio of grid current-to-plate current to be achieved. When the proper ratio is met, it will be found that when plate voltage is dopped to 2000 for c-w operation, the power input will automatically drop to 1 kW, and the only adjustment necessary to the amplifier may be a slight "touchup" of the driving level from the auxiliary exciter.

Once proper operation at 2000 and 3000 volts has been completed with a single-tone driving signal, the amplifier may be driven with a voice signal. Because of meter inertia and the relatively low power in the human voice, peak grid and plate current readings will average about one-half of the single-tone readings. Proper peak conditions for SSB may be monitored with an oscilloscope. Operation at 1-kW d-c input at 3000 volts plate potential is not recommended because efficiency is low due to the limited r-f plate-voltage swing.

28-9 A Kilowatt Linear Amplifier for Six Meters

Described in this section is a high-power amplifier expressly designed for six-meter operation. It is capable of 1-kilowatt PEP



Figure 46

3-400Z LINEAR AMPLIFIER PACKS KILOWATT PUNCH FOR THE SIX-METER OPERATOR

This compact kilowatt linear amplifier is suited for SSB, c-w or a-m service in the 50-MHz band. Utilizing the 3-400Z in a grounded-grid circuit, the amplifier requires neither bias nor screen voltage. The homemade cabinet is an "r-f tight" inclosure which helps to reduce TVI problems. Meters are shielded and are in the circuit at all times so no extra switching circuits are required. Panel size is only 8 3/4" X 13". Panel components are (l. to r.): Grid meter, r-f output meter, and plate meter. In the line below the meters are: r-f output calibration control, plate tuning, and antenna loading. Across the bottom of the panel are: input tuning, filament pilot light, and high-voltage pilot light.

input for sideband and c-w service, and will deliver a fully modulated carrier of about 200 watts as an a-m linear amplifier. A single Eimac 3-400Z zero-bias triode is used in this efficient, compact unit which is capable of delivering full output from an exciter providing 35 watts peak drive (or 15 watts carrier, amplitude-modulated). The cathode-driven (grounded-grid) configuration is utilized and neutralization is unnecessary.

The Amplifier Circuit The schematic of the six-meter amplifier is shown in figure 47. A tuned-cathode circuit (L_1-C_1) is used to preserve the waveform of the driving signal and to reduce harmonic distortion that may cause TVI.

The plate circuit of the amplifier utilizes a π -L network to achieve a high order of harmonic suppression and a simple diode

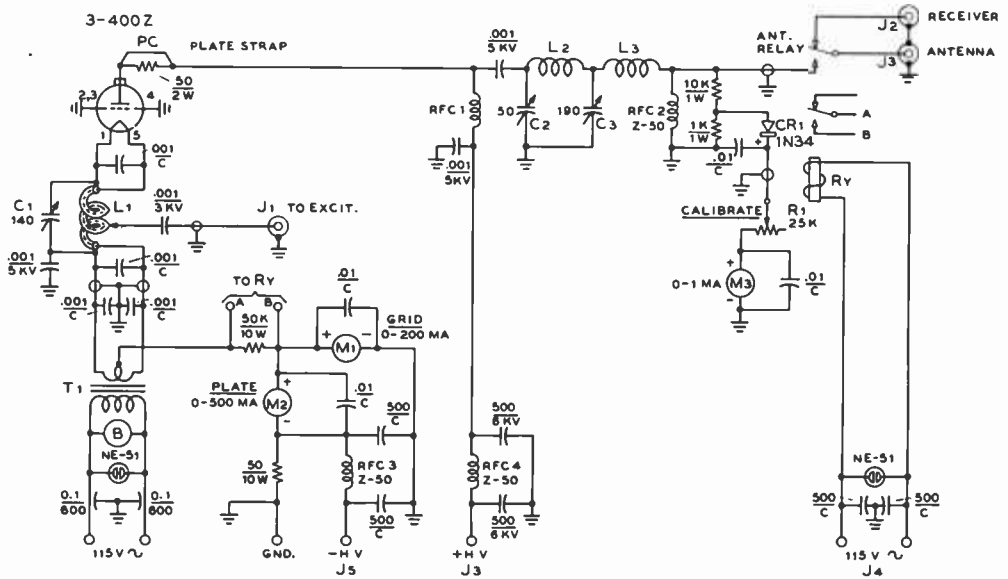

Figure 47

SCHEMATIC OF SIX-METER LINEAR AMPLIFIER

B—Blower. 13 cubic feet per minute at 0.13 inches of water. Dayton 2C-782 or equivalent

C₁—140 pf Bud 1856

C₂—50 pf, 0.07" spacing. Hammarlund MC-505X

C₃—190 pf. Bud 1858

J₁—TV-type chassis-mount cord socket

L₁—Bifilar coil. 3 turns, 1/8-inch diameter copper tubing spaced to 2", tapped 3/4 turn from grounded end. Inner conductor is No. 12 insulated or formvar wire (see text)

L₂—Pi-section coil. 5 turns, 3/16-inch copper tubing, spaced to 3". Inside diameter is 1 1/8".

L₃—L-section coil. 4 turns, 1/8-inch tubing, 3/4-inch inside diameter, spaced to 2 1/2"

RFC_{1,2,3}—3 μH choke. 48 turns No. 16 formvar wire closewound on 1/2" diameter standoff insulator.

RFC₄—Ohmite Z-50 choke

RY—Coaxial antenna relay. Dow Key DK60-G2C

T₁—5 volts at 15 A. Stancor P-6433

Note: 0.1 μf, 600-volt feedthrough capacitors are Sprague 80P-3. Meters are Simpson Wide-Vue.

voltmeter is used to monitor the r-f output voltage. An antenna relay (RY) is incorporated in the amplifier, and an alternative circuit is shown for using the linear amplifier with a transceiver (figure 48).

Metering and Suppression Circuits It is necessary to measure both grid and plate current in a cathode-driven amplifier to establish the proper ratio of grid to plate current. At the higher frequencies it is desirable to directly ground the grid of the amplifier tube and not to rely on questionable bypass capacitors to insure that the grid remains at ground potential. Grid cur-

rent, therefore, is measured in the cathode-return circuit of the amplifier by meter M₁.

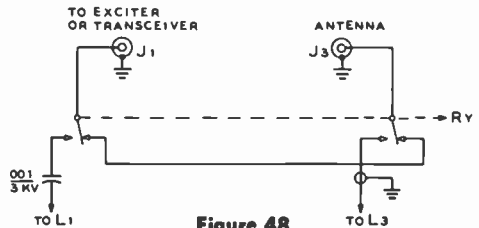

Figure 48

SUGGESTED ANTENNA-RELAY CIRCUIT FOR USING AMPLIFIER WITH TRANSCEIVER

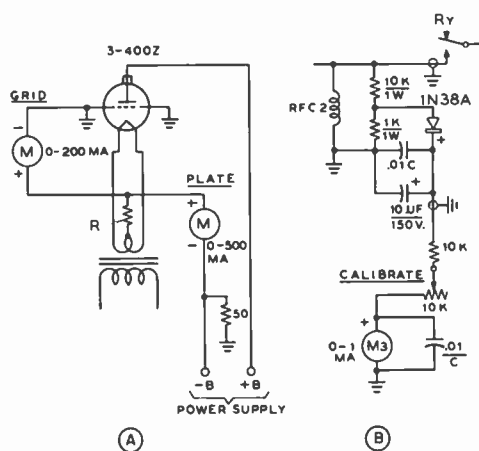

Figure 49

METERING CIRCUITS FOR KILOWATT AMPLIFIER

A—D-c meter circuit showing grid and plate meters placed in low-potential return leads. The B-minus of the power supply "floats" above ground by virtue of the 50-ohm resistor, which may be placed in the power supply, if desired.

B—Peak-responding voltmeter circuit useful for adjusting linear for a-m service.

Plate current is measured in the B-minus lead to the power supply by meter M₂. A simplified metering circuit is shown in figure 49.

This amplifier was checked for parasitics and it was found that the usual plate parasitic choke was not required for stable operation. A variation in circuit layout, however, or changes in ground-return currents may allow weak parasitic oscillation to take place. If this condition is found, placement of a parasitic choke in the plate lead will suppress the unwanted parasitic. A practical parasitic choke is shown in the schematic and is made by merely shunting a portion of the plate strap with a composition resistor.

Amplifier Construction The amplifier is included in an "r-f tight" cabinet measuring 13" × 8¾" × 10". A standard 12" × 10" × 3" aluminum chassis is used, along with an 8¾" × 13" panel (cut from a standard aluminum relay rack panel). The cabinet is made by bending a sheet of light aluminum (31" × 11") to fit around the panel. It is riveted to 13" × 11"

bottom plate. The rear of the cabinet is a sheet of perforated aluminum fastened to the cabinet with ½-inch aluminum angle stock. Additional angle stock is cut to length and fastened to the front edge of the cabinet to secure the panel. A 4-inch hole is cut in the cabinet directly above the 3-400Z and is covered with a small sheet of perforated aluminum. This shielded vent permits the heated air from the tube to escape from the inclosure.

A meter shield is used to protect the panel meters from the r-f field of the plate circuit and to suppress r-f leakage from the cabinet via the meter faces. The box-like shield is attached to the panel by means of aluminum angle stock which is held to the panel by the meter mounting bolts. All paint is removed from the rear of the panel to provide a good ground connection to the meter shield and to the chassis and cabinet.

The 3-400Z tube requires forced-air cooling during operation and a blower (B) is mounted on the chassis and activated with application of filament voltage. An *Eimac* SK-410 air-system socket and SK-416 air chimney are used to achieve proper air flow around the filament and plate seals of the tube.

Layout of the major components may be seen in the photographs. The air-system socket is mounted on the underside of the chassis in a 3½-inch diameter cutout. The spring clips that hold the chimney in place fasten with the same bolts used to mount the socket, which is oriented so that filament pins 1 and 5 are facing the front of the chassis. The cathode tuning capacitor (C₁) is mounted on the front apron of the chassis with insulated washers as the rotor is above ground by the amount of the filament voltage. The cathode coil is a dual winding, made of copper tubing having an insulated center conductor. A section of ⅛-inch soft-drawn copper tubing about a foot long is needed to make the coil. Before the coil is wound, the ends of the tubing are smoothed with a file and a length of No.12 cotton-covered (or *formvar*-insulated) wire is passed through the tubing. The coil is then wound about a ¾-inch diameter wood dowel rod used as a temporary form, spacing the three turns to a length of two inches. The

tubing is trimmed, and the inner wire is left projecting about ten inches from each end. The coil is mounted close to the tube socket (figure 51) with one end supported by the filament pins of the tube socket. The inner conductor is trimmed to length and soldered to one filament pin, and the tubing is connected to the other filament pin by means of a short length of copper strap about $\frac{1}{8}$ -inch wide, cut from copper "flashing" material. The end of the coil is equidistant from the filament pins. The strap encircles one end of the tubing and is soldered in place, with the other end soldered to the pin. The filament bypass capacitor is soldered directly between the filament pins of the socket. A second short length of copper strap jumpers the first strap to the stator of the cathode tuning capacitor.

The opposite end of the cathode coil is bypassed to ground by a ceramic capacitor which also supports the coil. The inner conductor is bypassed to the outside tubing at this point, and a length of copper strap makes a connection to the rotor of the tuning capacitor. The inner conductor continues over to the filament transformer and a second length of No. 12 wire is run from the copper tubing to the second transformer terminal.

The three grid pins of the 3-400Z socket are grounded by passing a $\frac{1}{4}$ -inch wide copper strap through the slot in the socket adjacent to each grid pin and soldering the strap directly to the flat tab on the pin. The straps are then bolted to the chassis just clear of the socket.

The Plate-Circuit Assembly Layout of the components above the chassis are shown in figure 50. The plate tuning and loading capacitors (C_2 and C_3) are mounted on $\frac{1}{2}$ -inch ceramic insulators. The tuning capacitor is rotated 90 degrees on its side and held in position with small aluminum brackets. A common ground connection made of a length of $\frac{1}{2}$ -inch wide copper strap connects the rear rotor terminals of the capacitors. In addition, the capacitor rotor wipers are connected to the common ground strap.

A second strap grounds the rotors to a common ground point on the chassis under

the stud of the high-voltage bypass capacitor at the lower end of the plate r-f choke. The shafts of the variable capacitors are driven with insulated couplers to prevent ground-loop currents from flowing through the shafts into the panel.

The plate r-f choke is homemade, and is wound on a $\frac{1}{2}$ -inch diameter ceramic insulator. A commercial choke may be used, if desired. The base of the choke screws on the bolt of the high-voltage feedthrough insulator on the chassis, and is bypassed at this point with a ceramic capacitor.

The coaxial antenna relay is mounted on the top of the chassis positioned so the output lead from the L-section of the tank



Figure 50

TOP VIEW OF 3-400Z LINEAR AMPLIFIER FOR 50 MHz

Placement of the major components above the chassis may be seen in this photograph. The meter shield has been removed for the photograph. Leads to the meter compartment are shielded, and bypass capacitors are mounted at the meter terminals.

Across the rear apron of the chassis (l. to r.) are: receiver receptacle (J_2); terminal strip (J_3); Millen high-voltage connector (J_4); Sprague feedthrough capacitors; and r-f exciter receptacle (J_5). At the bottom edge of the chassis are a ground connection and the relay voltage terminal (J_6).

The copper ground strap between the plate circuit tuning capacitors may be seen just behind the antenna relay.

circuit can be connected directly to the input receptacle. The connection is made by trimming down a coaxial connector and soldering a short length of #10 wire to the center terminal to make the connection to the coil. The *antenna* receptacle of the relay extends beyond the rear apron of the chassis and through the rear of the cabinet. The *receive* receptacle is fed with a length of RG-58/U coaxial cable which terminates at the coaxial receptacle on the rear apron of the chassis. An auxiliary set of contacts on the relay are used to short out the 50K self-bias resistor in the cathode circuit of the 3-400Z when transmitting. The resistor serves to bias the tube to near cutoff during periods of reception to prevent noise being generated which may interfere with reception of weak signals and also to reduce the standby drain on the power supply. The relay is actuated by the control or VOX circuit of the exciter, and the relay coil should be chosen to match the voltage delivered from the exciter control circuit.

A diode r-f voltmeter is mounted beneath the chassis in a small aluminum box positioned over the r-f feedthrough insulator which supports the end of the L-network above the chassis. The lead from the voltmeter circuit to the *calibrate* potentiometer on the panel is run in shield braid, as are the leads from the center tap of the filament transformer. Tight rubber grommets are used in all chassis holes to restrict air leaks.

Amplifier Adjustment When the amplifier has been wired and inspected, it is ready for initial checks. Air is directed into the tube socket by means of a temporary bottom plate (cardboard) taped to the chassis. Filament voltage is applied and the blower motor should start. A strong blast of air out of the tube chimney should be noted. Tube filament voltage should be adjusted to 5.0 volts at the socket with an accurate meter. Filament voltage is now removed and the input and output coaxial receptacles are temporarily terminated in 50-ohm, 1-watt composition resistors, which may be soldered across the receptacles for this test. A grid-dip meter is tuned to 50 MHz and brought near the cathode coil (the 3-400Z being in the socket). The meter

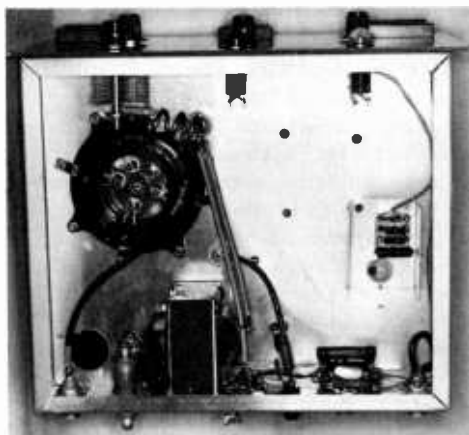

Figure 51

UNDER-CHASSIS VIEW OF LINEAR AMPLIFIER

The cathode circuit is mounted on the filament terminals of the air system socket (upper left), with the tuning capacitor (C₁) insulated from the panel. Filament leads run from the tuned circuit to the filament transformer mounted to the rear apron of the chassis. At the right is the small aluminum box (cover removed) holding the components for the r-f output voltmeter. The blower outlet is at the left corner of the chassis next to the feedthrough capacitors.

should show resonance with the cathode tuning capacitor about two-thirds meshed. The plate tank circuit is now tested, with the tuning capacitor about one-half meshed and the loading capacitor about two-thirds meshed. Grid-dip resonance at these settings for 50 MHz may be achieved by slight alterations in the spacing of the pi-network coil. The L-section should also show a dip around 50 MHz.

Once resonance of the tank circuits has been verified, the 50-ohm resistors are removed and the amplifier attached to the exciter and coaxial antenna lead. A separate ground lead is run from the amplifier to the power supply. A plate potential of 2500 volts is recommended as a maximum (key-down) value, and good operation can be obtained down to 2000 volts. At the higher potential, the resting plate current will be about 80 ma. Random variations in resting plate current, or a show of grid current when the controls are tuned (with no grid drive) is

an indication of parasitic oscillation and a plate parasitic choke should be installed.

After plate voltage is applied, grid drive is slowly injected until a plate current of about 150 ma is noted. The cathode circuit is resonated for maximum grid current and the plate tuning capacitor adjusted for plate-current dip. Grid drive is increased and loading adjustments made in the normal manner for pi-network operation to achieve a *single tone (carrier)* plate current of 400 ma at a grid current of about 140 ma. Proper loading is indicated by the ratio of plate current to grid current, which should be about 3:1.

For operation as a linear amplifier for SSB, carrier injection is used as described for tuning and loading. The relative-voltage output meter is very useful in the tuning process and provides a continuous check on proper operation as it increases in proportion to grid current. Maximum carrier input conditions are as stated above, and under these conditions, the anode of the 3-400Z will be a cherry red in color. With carrier removed and SSB voice modulation applied, drive is advanced until voice peaks reach about 200 ma plate current and about 70 ma grid current. For c-w operation, the full 400 ma plate current value may be run.

A-M Linear Operation The amplifier may be used for a-m linear service when properly adjusted. The amplifier efficiency at the peak of the modulation cycle is about 66 percent and efficiency under carrier conditions (no modulation) is about 33 percent. As maximum plate dissipation is 400 watts, the total a-m carrier input to the 3-400Z is limited to about 600 watts (2500 volts at 240 ma). In order to *properly* load the amplifier to this condition for a-m linear service, an oscilloscope and peak-responding voltmeter are necessary. The r-f output voltmeter in the amplifier may be converted to a peak-responding instrument as shown in figure 49B. In addition, a simple

1000-Hz audio oscillator is used for the following adjustments.

For preliminary tuneup, the a-m driver is modulated 100 percent with the 1000-Hz tone. A driver capable of about 15 watts carrier is required. The 3-400Z amplifier is loaded and drive level adjusted to 600 watts input under this condition. Amplifier output is monitored with the peak-responding voltmeter, which is adjusted to *full-scale* reading at the 600-watt input level. Grid current will run about $\frac{1}{4}$ the plate-current value, or approximately 60 ma. Once this condition is reached, the modulation of the driver is removed, leaving only carrier excitation. If the linear amplifier is properly adjusted, the indication of the peak-responding voltmeter should drop to *one-half scale*, corresponding to an output drop to one-quarter power.

If the peak-voltage drop when modulation is removed is less than one-half, the plate circuit loading and grid-drive level of the linear amplifier must be adjusted to provide the correct ratio. This is an indication that antenna loading is too light for the given grid drive. If this process is monitored with an oscilloscope, the point of flat-topping can be noted and drive and loading adjusted to remove the distortion on the peaks of the signal. Under voice modulation, plate and grid current will flicker a small amount upward.

The combination of a peak-responding voltmeter, an oscilloscope, and an audio oscillator used with tune-up under 100 percent single-tone modulation of the exciter affords a relatively easy and accurate method of achieving proper a-m linear amplifier service.

As with any cathode-driven amplifier, drive should never be applied to the amplifier in the absence of plate voltage, as damage to the grid of the tube may result. The proper sequence is to always apply plate voltage before drive, increasing the drive level slowly from a minimum value as tuning adjustments are made.

Speech and Amplitude-Modulation Equipment

Amplitude modulation of the output of a transmitter for radiotelephony may be accomplished either at the plate circuit of the final amplifier, commonly called *high-level amplitude modulation* or simply *plate modulation* of the final stage, or it may be accomplished at a lower level. Low-level modulation is accompanied by a plate-circuit efficiency in the final stage of 30 to 45 percent, while the efficiency obtainable with high-level amplitude modulation is about twice as great, running from 60 to 80 percent. Intermediate values of efficiency may be obtained by a combination of low-level and high-level modulation; cathode modulation of the final stage is a common way of obtaining combined low-level and high-level modulation.

High-level amplitude modulation is characterized by a requirement for an amount of peak audio power approximately equal to one-half the d-c input to the plate circuit of the final stage. Low-level modulation, as for example grid-bias modulation of the final stage, requires only a few watts of audio power for a medium-power transmitter and 10 to 15 watts for modulation of a stage with one kilowatt input. Cathode modulation of a stage normally is accomplished with an audio power capability of about 20

percent of the d-c input to the final stage. A detailed discussion of the relative advantages of the different methods for accomplishing amplitude modulation of the output of a transmitter is given in an earlier chapter.

Two trends may be noted in the design of systems for obtaining high-level amplitude modulation of the final stage of amateur transmitters. The first is toward the use of tetrodes in the output stage of the high-power audio amplifier which is used as the modulator for a transmitter. The second trend is toward the use of clipping and limiting circuits to control the maximum level of modulation.

29-1 Modulation

Tetrode Modulators In regard to the use of tetrodes, the advantages of these tubes have long been noted for use in modulators having from 10 to 100 watts output. The 6AQ5, 6L6 and 6146 tubes have served well in providing audio power outputs in this range. Recently the higher-power tetrodes such as the 813, and 4-250A, and the zero-bias triodes such as the

3-400Z have come into more general use as high-level audio amplifiers. The beam tetrodes offer the advantages of low driving power (even down to zero driving power for many applications) as compared to the high driving-power requirements of the usual triode tubes having equivalent power-output capabilities.

On the other hand, beam-tetrode tubes require both a screen-voltage power supply and a grid-bias source. So it still is expedient in many cases to use zero-bias triodes or even low- μ triodes such as the 340TL in many modulators for the medium-power and high-power range. A list of suggested modulator combinations for a range of power output capabilities is given later in this chapter.

Increasing the Effective Modulation Percentage It has long been known that the effective modulation percentage of a transmitter carrying unaltered speech waves was necessarily limited to a rather low value by the frequent high-amplitude peaks which occur in a speech waveform. Many methods for increasing the effective modulation percentage in terms of the peak modulation percentage have been suggested in various publications and subsequently tried in the field by the amateur fraternity. Two of the first methods suggested were *automatic modulation control* and *volume compression*. Both these methods were given extensive trials by operating amateurs; the systems do give a degree of improvement as evidenced by the fact that such arrangements still are used in many amateur stations. But these systems fall short of the optimum, because there is no essential modification of the speech waveform. Some method of actually modifying the speech waveform to improve the ratio of peak amplitude to average amplitude must be used before significant improvement is obtained.

It has been proved that the most serious effect on the radiated signal accompanying overmodulation is the strong spurious-sideband radiation which accompanies negative-peak clipping. Modulation in excess of 100 percent in the positive direction is accompanied by no undesirable effects as far as

the radiated signal is concerned, at least so long as the linear modulation capability of the final amplifier is not exceeded. So the problem becomes mainly one of constructing a modulator/final-amplifier combination so that negative-peak clipping (modulation in excess of 100 percent in a negative direction) cannot normally take place regardless of any reasonable speech input level.

Assymetrical Speech The speech waveform of the normal male voice is characterized, as was stated before, by high-amplitude peaks of short duration. But it is also a significant characteristic of this wave that these high-amplitude peaks are polarized in one direction with respect to the average amplitude of the wave. This is the "lopsided" or assymetrical speech which has been discussed and illustrated in an earlier chapter.

The simplest method of attaining a high average level of modulation without negative-peak clipping may be had merely by ensuring that these high-amplitude peaks always are polarized in a positive direction at the secondary of the modulation transformer. This adjustment may be achieved in the following manner: Couple a cathode-ray oscilloscope to the output of the transmitter in such a manner that the carrier and its modulation envelope may be viewed on the scope. Speak into the microphone and note whether the sharp peaks of modulation are polarized upward or whether these peaks tend to cut the baseline with the "bright spot" in the center of the trace which denotes negative-peak clipping. If it is not obvious whether or not the existing polarity is correct, reverse the polarity of the modulating signal and again look at the envelope. If a push-pull modulator is used, the easiest way of reversing signal polarity is to reverse either the leads which go to the grids or the leads to the plates of the modulator tubes.

When the correct adjustment of signal polarity is obtained through the above procedure, it is necessarily correct only for the specific microphone which was used while making the tests. The substitution of another microphone may make it necessary to again reverse the polarity, since the new

microphone may be connected internally in the opposite polarity to that of the original one.

Low-Level Speech Clipping The low-level speech clipper is, in the ideal case, a very practical method for obtaining an improved ratio of average-to-peak amplitude. Such systems, used in conjunction with a voice-frequency filter, can give a very worthwhile improvement in the effective modulation percentage; but in the normal a-m transmitter their operation is often less than ideal. The excessive phase shift between the low-level clipper and the plate circuit of the final amplifier in the transmitter results in a severe alteration in the square-wave output of the clipper-filter which results from a high degree of clipping. The square-wave output of the clipper ends up essentially as a double sawtooth wave by the time this wave reaches the plate of the modulated amplifier. The net result of the rather complex action of the clipper, filter, and the phase shift in the succeeding stages is that the low-level speech clipper system *does* provide an improvement in the effective modulation percentage, but it *does not* insure against overmodulation. An extensive discussion of these factors, along with representative waveforms, is given in Chapter Thirteen. Circuits for some recommended clipper-filter systems will also be found in the same chapter.

High-Level Splatter Suppressor One practical method for the substantial elimination of negative-peak clipping in a high-level a-m transmitter is the so-called *high-level splatter suppressor*. As figure 1 shows, it is only necessary to add a high-vacuum rectifier tube socket, a filament transformer, and a simple low-pass filter to an existing modulator/final-amplifier combination to provide high-level suppression.

The tube (V_1) serves to act as a switch to cut off the circuit from the high-voltage power supply to the plate circuit of the final amplifier as soon as the peak a-c voltage across the secondary of the modulation transformer has become equal and opposite

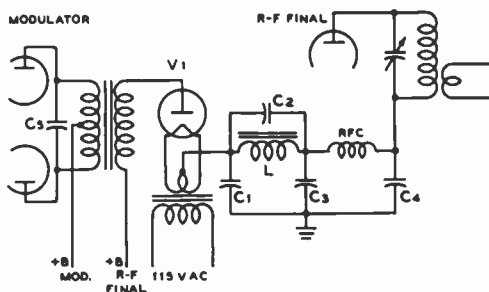

Figure 1

HIGH-LEVEL SPLATTER SUPPRESSOR

The high-vacuum diode acts as a series limiter to suppress negative-peak clipping in the modulated r-f amplifier as a result of large amplitude negative-peak modulating signals. In addition, the low-pass filter following the diode suppresses the transients which result from the peak-clipping action of the diode. Further, the filter attenuates all harmonics generated within the modulator system whose frequency lies above the cut-off frequency of the filter. The use of an appropriate value of capacitor, determined experimentally as discussed in Chapter Thirteen, across the primary of the modulation transformer (C_1) introduces further attenuation to high-frequency modulator harmonics. Chokes suitable for use at L are manufactured by Chicago-Stancor Co. The correct values of capacitance for C_1 , C_2 , C_3 , and C_4 are specified on the installation sheet for the splatter-suppressor chokes for a wide variety of operating conditions.

to the d-c voltage being applied to the plate of the final amplifier stage. A single-section low-pass filter serves to filter out the high-frequency components resulting from the clipping action.

Tube V_1 may be a receiver rectifier with a 5-volt filament for any but the highest power transmitters. The 5U4-GB is good for 250 ma plate current to the final stage, the 5V3-A is satisfactory for up to 350 ma. For high-power high-voltage transmitters the best tube is the high-vacuum transmitting tube type 836. It is a high-vacuum rectifier and utilizes a large-size heater-type dual cathode requiring a warmup time of at least 40 seconds before current should be passed. The tube is rated at an average current of 250 ma. For greater current drain by the final amplifier, two or more 836 tubes may be placed in parallel.

The filament transformer for the cathode of the splatter-suppressor tube must be insulated for somewhat more than twice the

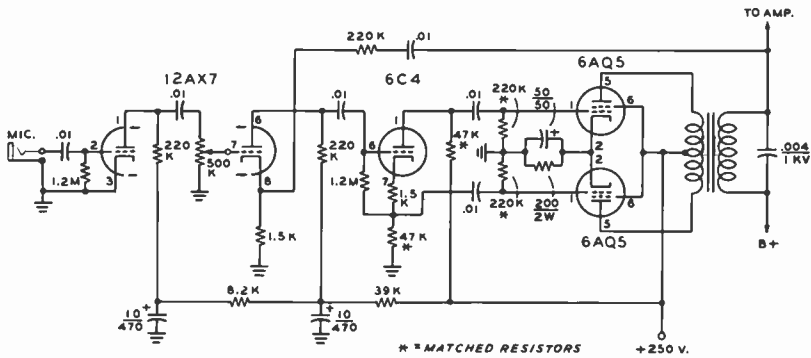

A 10-WATT 6AQ5 MODULATOR

Plate-to-plate load impedance of the output stage is 10K.

operating d-c voltage on the plate-modulated stage, to allow for a factor of safety on modulation peaks. A filament transformer of the type normally used with high-voltage rectifier tubes will be suitable for such an application.

29-2 General-Purpose Tetrode Modulators

A number of representative designs for speech amplifiers and modulators are given in this chapter. Still other designs are included in the descriptions of other items of equipment in other chapters. However, those persons who wish to design a speech amplifier or modulator to meet their particular needs are referred to Chapter Six, *Vacuum-Tube Amplifiers*, for additional data.

A 10-Watt Modulator This compact modulator is well suited for portable or mobile operation since it may be run from a 6- or 12-volt primary supply (figure 2). A 12AX7 two-stage speech amplifier drives a 6C4 hot-cathode phase inverter, in which a proportion of the output voltage is developed across a cathode load resistor, out of phase with the plate signal. Matched cathode and plate-load resistors ensure that the output signals from the 6C4 stage are equal in amplitude. Two 6AQ5 tetrodes are used in the class AB₁ modulator stage, de-

livering about 10 watts of audio power. A simple negative-feedback circuit from the secondary of the modulation transformer to the cathode of the second speech amplifier stage smooths the audio response, and provides improved regulation of the audio output voltage. The capacitor across the secondary winding of the modulation transformer is part of the feedback circuit, reducing any tendency of the circuit to oscillate at the higher audio frequencies.

It is important that the feedback be properly phased. If the amplifier oscillates, either the primary or secondary connections of the output transformer should be reversed. With a 250-volt plate supply the 6AQ5 tubes should have a bias of about -15 volts and a resting plate current of about 70 ma. At full power output, plate current will rise to about 80 ma or so. Maximum-signal cathode current is about 95 ma. For 12-volt operation, the filament sections of the 12AU7 should be wired in series. The 6AQ5's may be series connected, or 12AQ5 tubes used. The 6C4 requires a series filament resistor to operate on 12 volts.

10- to 120-Watt Modulator with Beam-Power Tubes It is difficult to surpass the capabilities of the reliable beam-power tube when an audio power output of 10 to 120 watts is required of a modulator. A pair of 6L6-G tubes operating in such a modulator will deliver good plate-

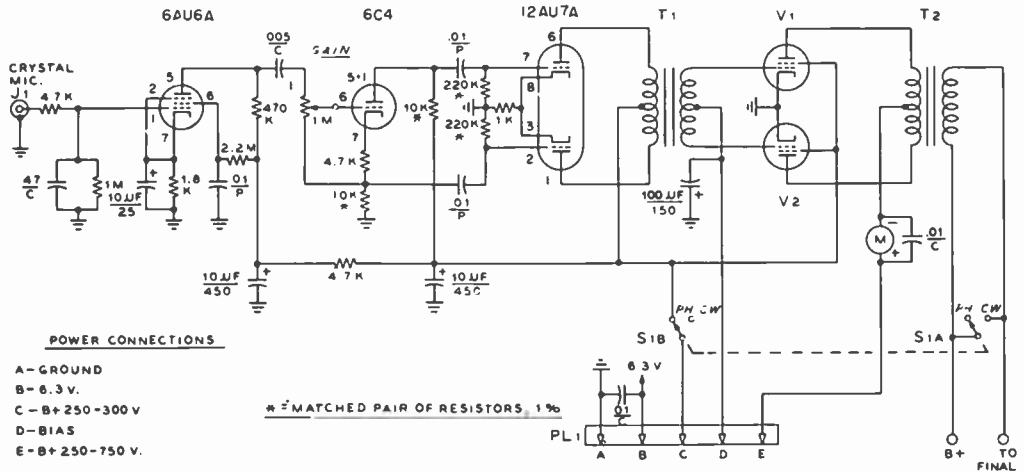

Figure 3

SCHEMATIC OF MEDIUM-POWER MODULATOR

M—0-250 d-c milliammeter
 T₁—Driver transformer. Stancor A-4701, or UTC S-10

T₂—Modulation transformer
 60-watt level = Stancor A-3893, or UTC S-10
 125-watt level = Stancor A-3894

circuit efficiency, require only a very small amount of driving power, and impose no serious grid-bias problems. Included on the chassis of the modulator shown in figure 3 are the speech amplifier, the driver and modulation transformers for the output tubes, and a plate-current milliammeter. The power supply has not been included. The 6AU6A pentode first stage is coupled through the volume control to the grid of a 6C4 phase inverter. The output of the phase inverter is capacitively coupled to the grids of a 12AU7A which acts as a push-pull driver for the output tubes. Transformer coupling is used between the driver stage and the grids of the output tubes so that the output stage may be operated either as a class-AB₁ or class-AB₂ amplifier.

The Output Stage Either 6L6, 6L6-G, or 807 tubes may be used in the output stage of the modulator. As a matter of fact, either 6V6-GT or 6F6-G tubes could be used in the output stage if somewhat less power output is required.

Listed in Table 1 are a group of recommended operating conditions for different tube types in the output stage of the modulator. In certain sets of operating conditions the tubes will be operated class AB₁, that is with increased plate current with signal but with no grid current. Other operating conditions specify class-AB₂ operation, in which

Table 1.

Recommended Operating Conditions for Modulator of Figure 3 for Different Tube Types							
Tubes V ₁ V ₂	Class	Plate Volts (E)	Screen Volts (C)	Grid Bias (D)	Plate-To-Plate Load (Ohms)	Plate Current (MA)	Power Output (Watts)
6V6GT	AB ₁	250	250	-15	10,000	70-80	10
6V6GT	AB ₁	285	285	-19	8,000	70-95	15
6L6	AB ₁	360	270	-23	6,600	85-135	27
6L6	AB ₂	360	270	-23	3,800	85-205	47
807	AB ₁	600	300	-34	10,000	35-140	56
807	AB ₁	750	300	-35	12,000	30-140	75
807	AB ₂	750	300	-35	7,300	30-240	120

the plate current increases with signal and grid current flows on signal peaks.

A High-Power Modulator with Beam Tetrodes

Listed in Table 2 are representative operating conditions for various tetrode tubes providing power levels up to 840 watts of audio. Complete operating data on these tube types may be obtained from the manufacturer. In the case of the 4-250A and 4-400A, both class AB₁ and AB₂ data are given. These tubes are electrically similar except that the 4-400A has greater plate dissipation. Class AB₁ operation of the modulator is recommended since it places less demand on the driver stage, and a simple transformer-coupled voltage amplifier may be used, such as the one shown in the circuit of figure 3.

Because of the power level involved and the design of the external-anode tube, the 4X150A/4CX250B tubes must be forced-air cooled in this application. It is recommended that the 813, 4-250A, and 4-400A tubes be convection cooled with a small fan. The modulator may be checked for correct operation as described in the next section.

29-3 General Purpose Triode Class-B Modulator

High level class-B modulators with power output in the 125- to 500-watt level usually

make use of triodes such as the 809, 811, 8005, 805, or 810 tubes with operating plate voltages between 750 and 2000. Figure 4 illustrates a general-purpose modulator unit designed for operation in this power range. The size of the modulation transformer will of course be dependent on the amount of audio power developed by the modulator. In the case of the 500-watt modulator the size and weight of the components require that the speech amplifier be mounted on a separate chassis. For power levels of 300 watts or less it is possible to mount the complete speech system on one chassis.

Circuit Description of General Purpose Modulator

The modulator unit shown in figure 4 is complete except for the high-voltage supply required by the modulator tubes. A speech amplifier suitable for operation with a crystal microphone is included on the chassis along with its own power supply. A 6AU6 is used as a high-gain preamplifier stage resistance coupled to a 12AU7 phase inverter. The audio level is controlled by a potentiometer in the input grid circuit of the 12AU7 stage. Push-pull 2A3 low- μ triodes serve as the class-B driver stage. The 2A3's are coupled to the grids of the modulator tubes through a conventional multipurpose driver transformer. Cathode bias is employed on the driver stage which is capable of providing 12 watts of audio power for the grid circuit of the modulator.

Table 2.

Recommended Operating Conditions for Tetrode Tubes for 400- to 800-Watt Power Level							
Tubes V_1, V_2	Class	Plate Volts E	Screen Volts C	Grid Bias D	Plate-to- Plate Lead (ohms)	Plate Current (ma)	Power Output (watts)
813	AB ₂	2500	750	-95	17,000	36 to 360	650
4-125A	AB ₂	2500	350	-43	22,000	90 to 260	400
4-250A	AB ₁	2500	300	-51	10,900	120 to 500	840
4-400A	AB ₂		600	-110	11,400	120 to 430	625
4X150A 4CX250B 4CX300A	AB ₁	2000	350	-55	9,500	200 to 500	600

Table 3.

Suggested Operating Conditions For General-Purpose Modulator					
Tubes V_1, V_2	Plate Voltage	Grid Bias (Volts)	Plate Current (Ma)	Plate- To- Plate Load (Ohms)	Sine Wave Power Output (Watts)
811-A	750	0	30-350	5,100	175
811-A	1000	0	45-350	7,400	245
811-A	1250	0	50-350	9,200	310
811-A	1500	-4.5	32-315	12,400	340
805	1250	0	148-400	6,700	300
805	1500	-16	84-400	8,200	370
810	2000	-50	60-420	12,000	450
810	2500	-75	50-420	17,500	500

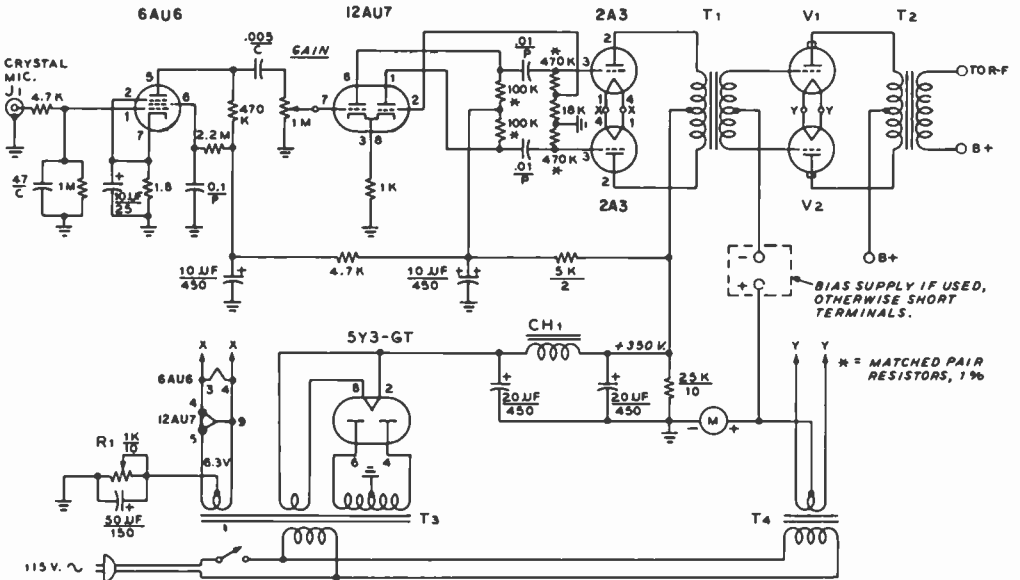

Figure 4

SCHEMATIC OF GENERAL PURPOSE MODULATOR

- M—0-500 ma.
- T₁—Driver transformer. Stancor A-4761
- T₂—"Poly-pedance" Modulation transformer. 300-watt rating, Stancor A-3898 500-watt rating, Stancor A-3899
- T₃—360-0-360 volts, 150 ma. Stancor PC-8410

- T₄—Suitable for tubes used. For 811-A's = 6.3 volt, 8 amp. Stancor P-6308 For 810's = 10 volt, 10 amp. Stancor P-6461
- CH₁—14 henry, 100 ma. UTC S-19. Stancor C-1001
- R₁—1K, 10 watts, adjustable. Set for plate current of 80 ma. (no signal) to 2A3 tubes (approximately 875 ohms).
- V₁, V₂—See Table 3.

For c-w operation the secondary of the class-B modulation transformer is shorted out and the filament and bias circuits of the modulator are disabled.

Modulator Adjustment When the modulator has been wired and checked, it should be tested before being used with an r-f unit. A satisfactory test setup is shown in figure 5. A common ground lead should be run between the speech amplifier and the modulator. A number of 1000-ohm 100-watt resistors are connected in series and placed across the high-voltage terminals of the modulator unit to act as an audio load. Bias should be adjusted to show the indicated value from grid terminal to ground as measured with a high-resistance voltmeter. If an oscilloscope is available, it should be coupled to point "A" on the load resistor through a 500-pf ceramic TV capacitor of 10,000 volts rating. The case of the

oscilloscope should be grounded to the common ground point of the modulator.

The listed plate voltage is now applied to the modulator, and bias is adjusted for proper resting plate current.

Be extremely careful during these adjustments, since the plate supply of the modulator is a

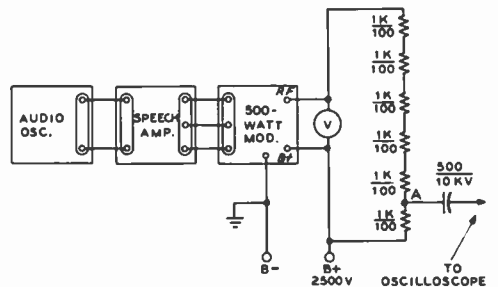

Figure 5

TEST SETUP FOR 500-WATT MODULATOR

lethal weapon. Never touch the modulator when the plate voltage supply is on! Be sure you employ the TV blocking capacitor between the oscilloscope and the plate-load resistors, as these load resistors are at high-voltage potential! If a high-resistance a-c voltmeter is available that has a 2000-volt scale, it should be clipped between the high-voltage terminals of the modulator, directly across the dummy load. Do not touch the meter when the high-voltage supply is in operation! An audio oscillator should be connected to the audio input circuit of the exciter-transmitter and the audio excitation to the high-level modulator should be increased until the a-c voltmeter across the dummy-load resistor indicates an rms reading that is equal to 0.7 (70%) of the plate voltage applied to the modulator. If the modulator plate voltage is 2500 volts, the a-c meter should indicate 1750 volts developed across the 6000-ohm dummy-load resistor. This is equivalent to an audio output of 500 watts. Under these conditions, the oscilloscope may be used to observe the audio waveform of the modulator when coupled to point "A" through the 10,000 volt coupling capacitor.

When the frequency of the audio oscillator is advanced above 3500 Hz the output level of the modulator as measured on the a-c voltmeter should drop sharply indicating that the low-pass audio network is functioning properly (if low-pass network is used).

29-4 A 15-Watt Clipper - Amplifier

The near-ultimate in "talk power" can be obtained with low-level clipping and filtering combined with high-level filtering. Such a modulation system will have real "punch," yet will sound well rounded and normal. The speech amplifier described in this section makes use of low-level clipping and filtering and is specifically designed to drive a pair of push-pull 810 modulators.

Circuit Description The schematic of the speech amplifier-clipper is shown in figure 6. A total of six tubes, including a rectifier are employed and the

unit delivers 15 watts of heavily clipped audio.

A 12AX7 tube is used as a two-stage microphone preamplifier and delivers approximately 20 volts (rms) audio signal to the 6AL5 series clipper tube. The clipping level is adjustable between 0 db and 15 db by clipping control R_2 . Amplifier gain is controlled by R_1 in the grid circuit of the second section of the 12AX7. A low-pass filter having a 3500-Hz cutoff follows the 6AL5 clipper stage, with an output of 5 volts peak audio signal under maximum clipping conditions. A double-triode 12AU7 cathode-follower phase inverter follows the clipper stage and delivers a 100-volt rms signal to the push-pull grids of the 2A3 audio driver tubes. The 2A3 tubes operate at a plate potential of 350 volts and have a -68 volt bias voltage developed by a small diode rectifier supply applied to their grid circuit. An audio output of 15 watts is developed across the secondary terminals of the class-B driver transformer with less than 5 percent distortion under conditions of no clipping. A 5U4-G and a choke-input filter network provide unusually good voltage regulation of the high-voltage plate supply.

The resistors in the 12AU7 phase-inverter plate circuit and the grid circuit of the 2A3 tubes should be matched to achieve best phase-inverter balance. The exact value of the paired resistors is not important, but care should be taken that the values are equal. Random resistors may be matched on an ohmmeter to find two units that are alike in value. When these matched resistors are soldered in the circuit, care should be taken that the heat of the soldering iron does not cause the resistors to shift value. The resistors should be held firmly by the lead to be soldered with a long-nose pliers, which will act as a heat sink between the soldered joint and the body of the resistor. If this precaution is taken the two phase-inverter outputs will be in close balance.

Adjustment of the Speech Amplifier When the wiring of the speech amplifier has been completed and checked, the unit is ready to be tested. Before the tubes are plugged in the amplifier,

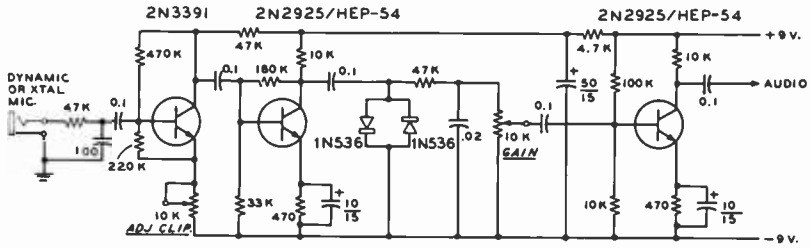

Figure 8

MORE COMPLEX CLIPPER/AMPLIFIER

2N3391 transistor. It is recommended that either clipper be adjusted for maximum performance with an oscilloscope attached to the transmitter.

29-6 Zero Bias Tetrode Modulators

Class-B zero bias operation of tetrode tubes is made possible by the application of the driving signal to the two grids of the tubes as shown in figure 9. Tubes such as the 6AQ5, 6L6, 807, 803, and 813 work well in this circuit and neither a screen supply nor a bias supply is required. The drive requirements are low and the tubes operate with excellent plate circuit efficiency. The series grid resistors for the small tubes are required to balance the current drawn by the two grids, but are not needed in the case of the 803 and 813 tubes.

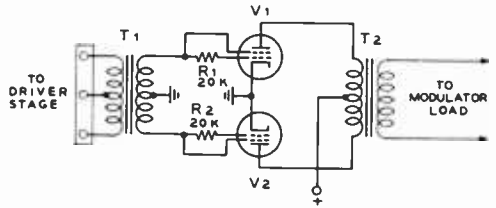

Figure 9

**ZERO BIAS TETRODE MODULATOR
ELIMINATES SCREEN AND BIAS
SUPPLIES**

Low driving power and simplicity are key features of this novel modulator. Tubes ranging in size from 6AQ5's to 813's may be employed in this circuit.

- T₁—Class-B driver transformer*
- T₂—Modulation transformer*
- V₁, V₂—6AQ5, 6L6, 807, 803, 813, etc.*
- R₁, R₂—Not used with 803 and 813*

Power Supplies

Vacuum tubes and solid-state devices require an essentially pure direct current power supply for proper operation. Primary power is usually taken from the home electrical system which, in the United States, is nominally 117/240 volts, 60 hertz, in a 3-wire, grounded-neutral circuit. For mobile or portable operation, the primary power source is often a 6- or 12-volt automotive system.

In the common case of the home electrical system, the various d-c voltages required for communication equipment are supplied by a transformer, rectifier and filter network used in conjunction with a control and overload protection device.

In view of the high cost of iron-core components which make up the bulk of a power supply, it is well to carefully consider the design of a power supply in terms of minimum requirements which will permit desired performance to be obtained from the supply. Thus, the a-c primary power must be economically converted to high and lower d-c voltages for the proper operation of the various circuits in the equipment. In addition, certain circuits require voltage control or voltage regulation for proper operation. This Chapter covers the design and assembly of suitable power supplies and control circuits for amateur communication equipment.

30-1 Power-Supply Requirements

A power supply for a transmitter or for a unit of station equipment should be designed

in such a manner that it is capable of delivering the required current at a specified voltage, that it has a degree of regulation consistent with the requirements of the application, that its ripple level at full current is sufficiently low for the load which will be fed, that its internal impedance is sufficiently low for the job, and that none of the components shall be overloaded with the type of operation contemplated.

The meeting of all the requirements of the previous paragraph is not always a straightforward and simple problem. In many cases compromises will be involved, particularly when the power supply is for an amateur station and a number of components already on hand must be fitted into the plan.

The arrival at the design for the power supply for use in a particular application may best be accomplished through the use of a series of steps, with reference to the data in this chapter by determining the values of components to be used. The first step is to establish the operating requirements of the power supply. In general these are:

1. Output voltage required under full load.
2. Minimum, normal, and peak output current.
3. Voltage regulation required over the current range.
4. Ripple voltage limit.
5. Rectifier circuit to be used.

The *output voltage* required of the power supply is more or less established by the operating conditions of the tubes which it will supply. The *current rating* of the supply, however, is not necessarily tied down by a particular tube combination. It is always best to design a power supply in such a manner that it will have the greatest degree of flexibility; this procedure will in many cases allow an existing power supply to be used without change as a portion of a new transmitter or other item of station equipment.

Current-Rating Considerations The *minimum current drain* which will be taken from a power supply will be, in most cases, merely the bleeder current. There are many cases where a particular power supply will always be used with a moderate or heavy load on it, but when the supply is a portion of a transmitter it is best to consider the minimum drain as that of the bleeder. The minimum current drain from a power supply is of importance since it, in conjunction with the nominal voltage of the supply, determines the minimum value of inductance which the input choke must have to keep the voltage from soaring when the external load is removed.

The *normal current rating* of a power supply usually is a round-number value chosen on the basis of the transformers and chokes on hand or available from the catalog of a reliable manufacturer. The current rating of a supply to feed a steady load such as a receiver, a speech amplifier, or a continuously operating r-f stage should be at least equal to the steady drain of the load. However, other considerations come into play in choosing the current rating for a keyed amplifier, an amplifier of SSB signals, or a class-B modulator. In the case of a supply which will feed an intermittent load such as these, the current ratings of the transformers and chokes may be *less* than the maximum current which will be taken; but the current ratings of the rectifier system to be used should be at least equal to the maximum current which will be taken. That is to say that 300-ma transformers and chokes may be used in the supply for a modulator whose resting current is 100 ma but whose maximum current at

peak signal will rise to 500 ma. However, the rectifier system should be capable of handling the full 500 ma.

The iron-core components of a power supply which feeds an intermittent load (such as demanded by an SSB transmitter) may be chosen on the basis of the current averaged over a period of several minutes, since it is the heating effect of the current which is of greatest importance in establishing the rating of such components. Since iron-core components have a relatively large amount of thermal inertia, the effect of an intermittent heavy current is offset to an extent by a resting period between words and syllables, or by key-up periods in the case of c-w transmission. However, the current rating of a rectifier tube is established by the magnitude of emission available from the filament of the tube, and the rating of a semiconductor rectifier is established by the maximum temperature limit of the rectifier element, both of which cannot be exceeded even for a short period of time or the rectifier will be damaged.

The above considerations are predicated, however, on the assumption that none of the iron-core components will become saturated due to the high level of intermittent current drain.

Voltage Regulation Since the current drain of a power supply can vary over a large magnitude, it is important to determine what happens to the output voltage of the supply with regard to change in current. Power-supply regulation may be expressed in terms of *static* and *dynamic* regulation. Static regulation relates to the regulation under long-term conditions of change in load whereas dynamic regulation relates to short-term changes in load conditions. Regulation is expressed as a change in output voltage with respect to load:

$$\text{Percent Regulation} = \frac{(E_1 - E_2) \times 100}{E_2}$$

where,

E_1 is no-load voltage,
 E_2 is full-load voltage.

Thus static regulation concerns itself with the "on" and "off" voltages of the power

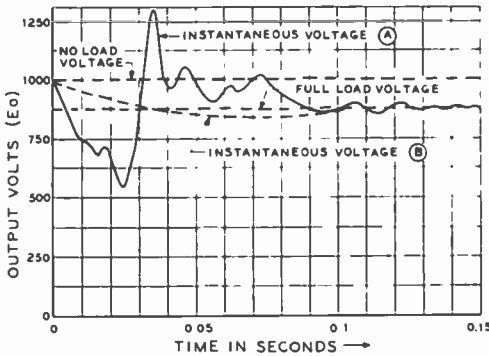

Figure 1
STATIC AND DYNAMIC REGULATION

- A—Dynamic regulation illustrates voltage peaks caused by transient oscillations in filter network.
- B—Static regulation is expressed in terms of no-load and full-load currents and voltages.

supply and dynamic regulation concerns itself with syllabic or keyed fluctuations in load. Static regulation is expressed in terms of average voltages and currents, whereas dynamic regulation takes into account instantaneous voltage variations caused by peak currents, or currents caused by undesired transient oscillations in the filter section of the power supply. In particular, c-w and SSB transmissions having a high peak-to-quiescent ratio of current drain are affected by poor dynamic regulation in the power system.

Examples of static and dynamic regulation are shown in figure 1. In example A, the no-load power-supply voltage is 1000 and the full-load voltage is 875. Static regulation is therefore 14.3 percent. If an oscilloscope is used to examine the supply voltage during the first fractions of a second when the full load is applied, the instantaneous voltage follows the erratic plot shown in curve A of figure 1. The complex pattern of voltage fluctuations, or transients, are related to resonant frequencies present in the power-supply filter network and are of sufficient magnitude to distort the waveform of c-w signals, or to appreciably increase intermodulation distortion and alter the first syllable of speech in an SSB system. Proper design of the filter system can reduce dynamic voltage fluctuations to a minimum

and, at the same time, greatly improve the static regulation of the power supply.

Static and dynamic regulation values of about 10 percent or so are considered to be limits of good design practice in amateur transmitting equipment, as illustrated by voltage curve B in figure 1.

Ripple Voltage The alternating component of the output voltage of a d-c power supply is termed the *ripple voltage*. It is superimposed on the d-c voltage, and the effectiveness of the filter system can be expressed in terms of the ratio of the rms value of the ripple voltage to the d-c output voltage of the supply. Good design practice calls for a ripple voltage of less than 5 percent of the supply voltage for SSB and c-w amplifier service, and less than 0.01 percent of the supply voltage for oscillators and low-level speech amplifier stages.

Ripple frequency is related to the number of pulsations per second in the output of the filter system. A full-wave rectifier, having two pulses of 60 Hz, for example, produces a 120-Hz ripple wave. A simple capacitive filter will reduce 120-Hz ripple as shown in figure 2. Ripple is an inverse ratio with capacitance, so doubling the capacitance will halve the ripple.

Ripple Filter Circuits The percentage of ripple found in representa-

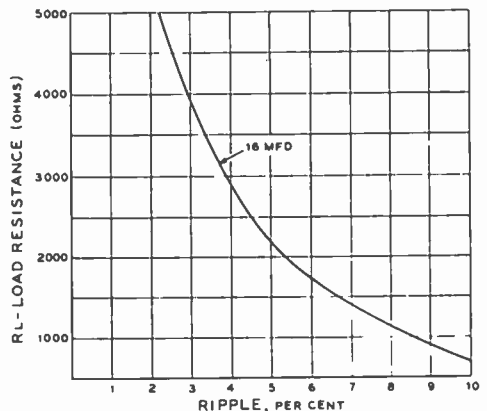

Figure 2

120-Hz RIPPLE ON 16-μFD CAPACITOR AS FUNCTION OF LOAD RESISTANCE

tive LC filter circuits is shown in figure 3. The approximate ripple percentage for filter components may be calculated with the aid of the following formulas, assuming the power line frequency to be 60 Hz and the use of a full-wave or full-wave-bridge rectifier circuit. The ripple at the output of the first section of a two-section choke input filter is:

$$\text{Percent Ripple} = \frac{118}{(L \times C) - 1}$$

where,

L is the input choke inductance in henrys (at the operating current to be used),

C is the capacitance which follows the choke, expressed in microfarads.

In the case of a two-section filter, the percent ripple at the output of the first section is determined by the foregoing formula.

This percentage is multiplied by the filter reduction factor of the following section of filter. This reduction factor is determined through the use of the following formula:

$$\text{Filter reduction factor} = \frac{1.76}{LC - 1}$$

where *LC* again is the product of the inductance and capacitance of the filter section. The reduction factor will turn out to be a decimal value, which is then multiplied by the percentage ripple obtained from the use of the preceding formula.

As an example, take the case of the filter diagramed in figure 4. The *LC* product of the first section is 16. So the ripple to be expected at the output of the first section will be: 118/(16-1) or 118/15, which gives 7.87 percent. Then the second section, with an *LC* product of 48, will give a reduction factor of: 1.76/(48-1) or 1.76/47 or 0.037. Then the ripple percentage at the output of the total filter will be: 7.87 times 0.037 or slightly greater than 0.29 percent ripple.

Resistance-Capacitance Filters In many applications where current drain is relatively small, so that the voltage drop across the series resistor would not be excessive, a filter system made up of resistors and capacitors only may be used to advantage. In the normal case, where the reactance of the shunting capacitor is very much smaller than the resistance of the load fed by the filter system, the ripple reduction per section is equal to 1/(2πRC). In terms of the 120-Hz ripple from a full-wave rectifier the ripple-reduction factor becomes: 1.33/RC where *R* is expressed in thousands of ohms and *C* in microfarads. For 60-Hz ripple the expression is: 2.66/RC with *R* and *C* in the same quantities as above.

Filter-System Resonance Many observers have noticed that at some value of load current the power supply will

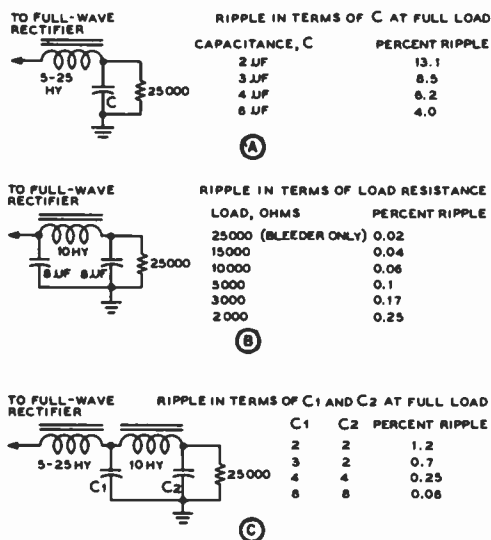

Figure 3

VALUES OF RIPPLE VOLTAGE FOR STANDARD POWER-SUPPLY CIRCUITS

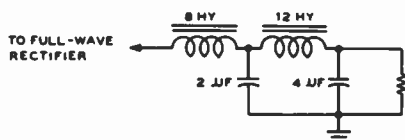

Figure 4

SAMPLE FILTER FOR CALCULATION OF RIPPLE

begin to hum excessively and mercury-vapor rectifier tubes (if used) will tend to flicker or one tube will seem to take all the load while the other tube dims out. This condition, as well as other less obvious phenomena such as eventual filter capacitor breakdown or short rectifier life are brought about by a resonant condition in the filter system.

A 120-Hz resonance is achieved when the product of inductance and capacitance is 1.77. Thus, a 1- μ fd capacitor and a 1.77-henry choke will resonate at 120 Hz. The LC product for resonance at 60 Hz is about 7.1. This latter value may occur when a 2- μ fd capacitor is used with a 3.55-henry choke, for example. The LC products of 1.77 and 7.1 should be avoided to prevent resonance effects, which can result in destructive transient voltages in the power-supply system. In particular, the use of a swinging choke (one whose inductance varies with current) may lead to resonance effects, because the inductance of such a device may vary over a 5-to-1 range. It is possible for 60-Hz resonance to occur at a low value of current drain, and then for 120-Hz resonance to occur at near-full load current. When a swinging-type input choke is used in the filter system, the LC product must be greater than 7.1 at maximum current drain to eliminate unwanted supply resonances.

Back EMF It is possible to place the filter choke in the B-minus lead of the power supply, reducing the voltage potential appearing from choke winding to ground. However, the *back-emf* of a good choke is quite high and can develop a dangerous potential from center tap to ground on the secondary winding of the plate transformer. If the transformer is not designed to withstand this potential, it is possible to break down the insulation at this point.

30-2 Power-Supply Components

The usual components which make up a power supply, in addition to rectifiers which have already been discussed, are filter capacitors, bleeder resistors, transformers, and

chokes. These components normally will be purchased especially for the intended application, taking into consideration the factors discussed earlier in this chapter.

Filter Capacitors There are two types of filter capacitors: (1) paper-dielectric type, (2) electrolytic type.

Paper capacitors consist of two strips of metal foil separated by several layers of special paper. Some types of paper capacitors are wax-impregnated, but the better ones, especially the high-voltage types, are oil-impregnated and oil-filled. Some capacitors are rated both for *flash* test and normal operating voltages; the latter is the important rating and is the maximum voltage which the capacitor should be required to withstand in service.

The capacitor across the rectifier circuit in a capacitor-input filter should have a working-voltage rating equal at *least* to 1.41 times the rms voltage output of the rectifier. The remaining capacitors may be rated more nearly in accordance with the d-c voltage.

The *electrolytic capacitor* consists of two aluminum electrodes in contact with a conducting film which acts as an *electrolyte*. A very thin film of oxide is formed on the surface of one electrode, called the *anode*. This film of oxide acts as the dielectric. The electrolytic capacitor must be correctly connected in the circuit so that the anode always is at a positive potential with respect to the electrolyte, the latter actually serving as the other electrode (plate) of the capacitor. A reversal of the polarity for any length of time will ruin the capacitor.

The high capacitance of electrolytic capacitors results from the thinness of the film which is formed on the plates. The maximum voltage that can be safely impressed across the average electrolytic filter capacitor is between 450 and 600 volts; the working voltage is usually rated at 450. When electrolytic capacitors are used in filter circuits of high-voltage supplies, the capacitors should be connected in series. The positive terminal of one capacitor must connect to the negative terminal of the other, in the same manner as dry batteries are connected in series.

Electrolytic capacitors can be greatly reduced in size by the use of etched aluminum foil for the anode. This greatly increases the surface area, and the dielectric film covering it, but raises the power factor slightly. For this reason, ultramidget electrolytic capacitors ordinarily should not be used at full rated d-c voltage when a high a-c component is present as would be the case for the input capacitor in capacitor-input filter.

Bleeder Resistors A heavy-duty resistor should be connected across the output of a filter in order to draw some load current at all time. This resistor avoids soaring of the voltage at no load when swinging-choke input is used, and also provides a means for discharging the filter capacitors when no external vacuum-tube circuit load is connected to the filter. This *bleeder* resistor should normally draw approximately 10 percent of the full load current.

The power dissipated in the bleeder resistor can be calculated by dividing the square of the d-c voltage by the resistance. This power is dissipated in the form of heat, and, if the resistor is not in a well-ventilated position, the wattage rating should be higher than the actual wattage being dissipated. High-voltage, high-capacitance filter capacitors can hold a dangerous charge if not bled off, and wirewound resistors occasionally open up without warning. Hence it is wise to place carbon resistors in series across the regular wirewound bleeder.

Several small resistors may be connected in series, if desired, to obtain the required wattage and voltage rating.

Transformers Power transformers and filament transformers normally will give no trouble over a period of many years if purchased from a reputable manufacturer, and if given a reasonable amount of care. Transformers must be kept dry; even a small amount of moisture in a high-voltage unit will cause quick failure. A transformer which is operated continuously, within its ratings, seldom will give trouble from moisture, since an economically designed transformer operates at a moderate temperature rise above the temperature of

the surrounding air. But an unsealed transformer which is inactive for an appreciable period of time in a highly humid location can absorb enough moisture to cause early failure.

Filter Choke Coils Filter inductors consist of a coil of wire wound on a laminated iron core. The size of wire is determined by the amount of direct current which is to flow through the choke coil. This direct current magnetizes the core and reduces the inductance of the choke coil; therefore, filter choke coils of the *smoothing* type are built with an air gap of a small fraction of an inch in the iron core, for the purpose of preventing saturation when maximum current flows through the coil winding. The "air gap" is usually in the form of a piece of fiber inserted between the ends of the laminations. The air gap reduces the initial inductance of the choke coil, but keeps it at a higher value under maximum load conditions. The coil must have a great many more turns for the same initial inductance when an air gap is used.

The d-c resistance of any filter choke should be as low as practical for a specified value of inductance. Smaller filter chokes, such as those used in radio receivers, usually have an inductance of from 6 to 15 henrys, and a d-c resistance of from 200 to 400 ohms. A high d-c resistance will reduce the output voltage, due to the voltage drop across each choke coil. Large filter choke coils for radio transmitters and class-B amplifiers usually have less than 100 ohms d-c resistance.

30-3 Rectification Circuits

There are a large variety of rectifier circuits suitable for use in power supplies. Figure 5 shows the three most common circuits used in supplies for amateur equipment.

Half-Wave Rectifier A *half-wave rectifier* (figure 5A) passes current in one direction but not in the other. Dur-

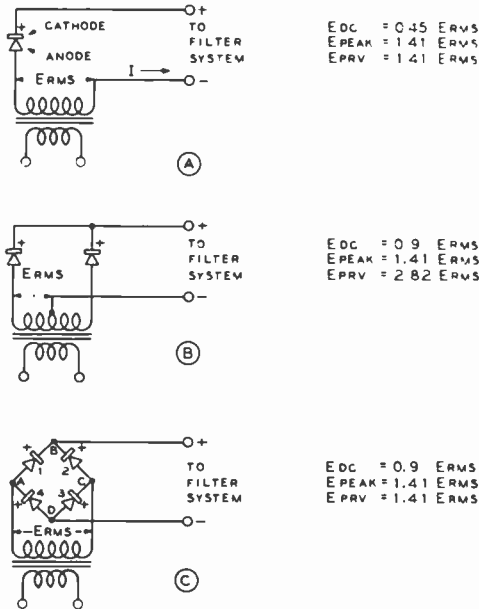

Figure 5

COMMON RECTIFIER CIRCUITS

- A—Half-wave rectifier. Ripple is 121%.
- B—Full-wave rectifier. Ripple is 48%.
- C—Bridge rectifier. Ripple is 48%.

ing one half of an applied a-c cycle when the anode of the rectifier is positive with respect to the cathode the rectifier is in a state of conduction and current flows through the rectifier. During the other half of the cycle, when the anode is negative with respect to the cathode, the rectifier does not conduct and no current flows in the circuit. The output current, therefore, is of a pulsating nature which can be smoothed into direct current by means of an appropriate filter circuit. The output of a half-wave rectifier is zero during one-half of each a-c cycle; this makes it difficult to filter the output properly and also to secure good voltage regulation for varying loads. The peak inverse voltage with a resistive or inductive load is equal to the peak a-c voltage of the transformer ($1.41 \times E_{RMS}$) and is equal to twice the peak a-c voltage with a capacitive load.

Full-Wave Rectifier A full wave rectifier (figure 5B) consists of a pair of half-wave rectifiers working on opposite

halves of the a-c cycle, connected in such a manner that each portion of the rectified wave is combined in the output circuit, as shown in figure 6. A transformer with a center-tapped secondary is required. The transformer delivers a.c. to each anode of each rectifier element; one anode being positive at any instant during which the other anode is negative. The center point of the high-voltage winding of the transformer is taken as the negative (B-minus) connection.

The cathodes of the rectifier units are always positive in polarity with respect to the anode of this type of circuit, and the output current pulsates 120 times per second for a 60-Hz supply. The peak output voltage is 1.4 times the rms transformer voltage and the inverse voltage across each rectifier unit is 2.8 times the rms voltage of the transformer (as measured across one half of the secondary winding). For a given value of ripple, the amount of filter required for a full-wave rectifier is half that required for a half-wave rectifier, since the ripple frequency of the former is twice that of the latter.

Bridge Rectifier A bridge rectifier (figure 5C) has four rectifier elements operated from a single a-c source. During one half-cycle of the applied a-c voltage, point A becomes positive with respect to point C and conduction takes place through rectifiers 4 and 2. During the other half of the cycle, conduction takes place through rectifiers 3 and 1 when point C is positive with respect to point A. On one half of the cycle, therefore, rectifiers 4 and 2 are in series with the output circuit and on the other half-cycle, rectifiers 3 and 1 are in series with the circuit. The bridge circuit is a full-wave system since current flows during both halves of a cycle of the alternating current.

One advantage of a bridge-rectifier connection over a full-wave, two-rectifier system is that with a given transformer voltage the bridge circuit produces a voltage output nearly twice that of the conventional full-wave circuit. In addition, the peak inverse voltage across any rectifier unit is half the peak inverse voltage impressed on a rectifier in the full-wave circuit. Maximum out-

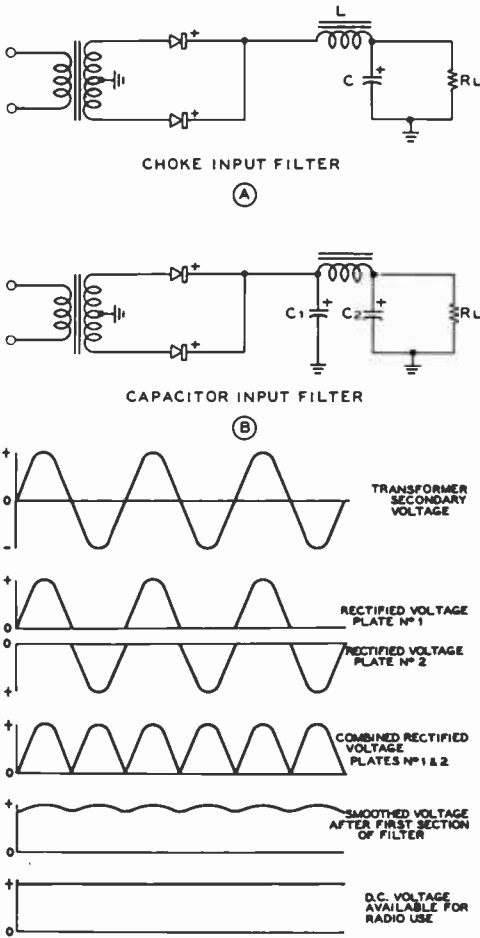

Figure 6

RECTIFICATION AND FILTER ACTION

Showing transformer secondary voltage, the rectified output of each diode, the combined output of the rectifiers, the smoothed voltage after the choke-input filter, and the d-c output voltage of the capacitor input filter.

put voltage into an inductive or resistive load is about 0.9 times the rms transformer voltage.

The center point of the high-voltage winding of the bridge transformer is not at ground potential. Many transformers having a center-tapped high voltage winding are not designed for bridge service and insulation between this point and the transformer

core is inadequate. Lack of insulation at this point does no harm in a full-wave circuit when the center tap is grounded, but may cause breakdown when the transformer is used in bridge configuration.

Rectifier Circuits *Choke input* is used in many filter systems because it gives good utilization of both rectifier and power-transformer capability (figure 6A). In addition, it provides much better voltage regulation than does a *capacitor input* system. A minimum value of choke inductance exists, and this critical value is equal to $R_L/1000$, where R_L is the load resistance. Inductance above the critical value will limit the no-load output voltage to about the average value ($E_{d.c.}$) in contrast to the capacitor-input filter circuit (figure 6B) wherein the no-load output voltage may rise as high as the peak value of the transformer voltage. The capacitor-input filter, at full load, provides a d-c output voltage that is usually slightly above the rms voltage of the transformer.

When capacitor input is used, consideration must be given to the peak value of the a-c voltage impressed on the filter capacitor, which usually runs equal to the peak transformer voltage ($1.41 E_{rms}$). The input capacitor, therefore, must have a voltage rating high enough to withstand the peak voltage if breakdown is to be avoided. A complete discussion of capacitor- and choke-input filter systems is contained in the *Radiotron Designer's Handbook*, published by the Radio Corporation of America, Harrison, New Jersey.

Special Single-Phase Rectification Circuits

Figure 7 shows six circuits which may prove valuable when it is desired to obtain more than one output voltage from one plate transformer or where some special combination of voltages is required. Figure 7A shows a more or less common method for obtaining full voltage and half voltage from a bridge rectification circuit. With this type of circuit, separate input chokes and filter systems are used on both output voltages. If a transformer designed for use with a full-wave rectifier is used in this circuit, the current

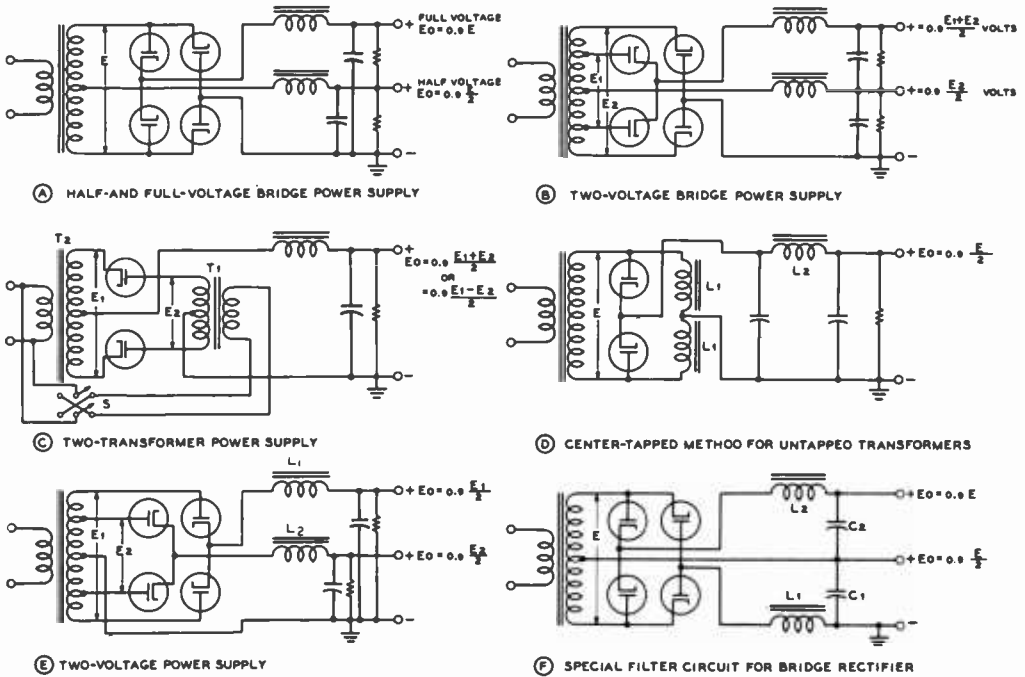

Figure 7

SPECIAL SINGLE-PHASE RECTIFICATION CIRCUITS

A description of the application and operation of each of these special circuits is given in the accompanying text.

drain from the full-voltage tap is doubled and added to the drain from the half-voltage tap to determine whether the rating of the transformer is being exceeded.

Figure 7B shows a system which may be convenient for obtaining two voltages which are not in a ratio of 2 to 1 from a bridge-type rectifier; a transformer with taps along the winding is required for the circuit however. With the circuit arrangement shown, the voltage from the tap will be greater than one-half the voltage at the top.

An interesting variable-voltage circuit is shown in figure 7C. The arrangement may be used to increase or decrease the output voltage of a conventional power supply, as represented by transformer T_1 , by adding another filament transformer to isolate the filament circuits of the two rectifier tubes and adding another plate transformer between the filaments of the two tubes. The

voltage contribution of the added transformer T_2 may be subtracted from or added to the voltage produced by T_1 , simply by reversing the double-pole double-throw switch (S). A serious disadvantage of this circuit is the fact that the entire secondary winding of transformer T_2 must be insulated for the total output voltage of the power supply.

An arrangement for operating a full-wave rectifier from a plate transformer not equipped with a center tap is shown in figure 7D. The two chokes (L_1) must have high inductance ratings at the operating current of the plate supply to hold down the alternating current load on the secondary of the transformer since the total peak voltage output of the plate transformer is impressed across the chokes alternately. However, the chokes need only have half the current rat-

ing of the filter choke (L_2) for a certain current drain from the power supply since only half the current passes through each choke. Also, the two chokes (L_1) act as input chokes so that an additional swinging choke is not required for such a power supply.

A conventional two-voltage power supply with grounded transformer center tap is shown in figure 7E. The output voltages from this circuit are separate and not additive as in the circuit of figure 7B.

A special bridge rectifier is shown in figure 7F. Both L_1 and L_2 should be swinging chokes but the total drain from the power supply passes through L_1 while only the drain of the final amplifier passes through L_2 . Capacitors C_1 and C_2 need be rated only half the maximum output voltage of the power supply, plus the usual safety factor. This ar-

range is also of advantage in holding down the "key-up" voltage of a c-w transmitter since both L_1 and L_2 are in series, and their inductances are additive, insofar as the "critical inductance" of a choke-input filter is concerned. If 20- μ fd capacitors are used at both C_1 and C_2 adequate filtering will be obtained on both plate supplies for hum-free SSB operation.

Polyphase Rectification Circuits

It is usual practice in commercial equipment installations when the power drain from a plate supply is to be greater than about one kilowatt to use a *polyphase rectification system*. Such power supplies offer better transformer utilization, less ripple output and better power factor in the load placed on the a-c line. However, such systems require a source of three-phase

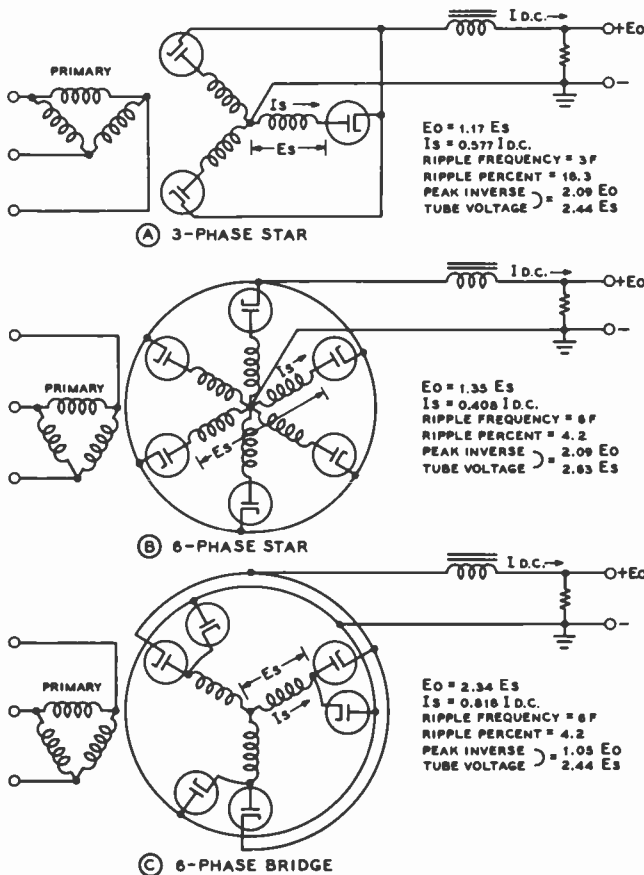

Figure 8
COMMON POLYPHASE-RECTIFICATION CIRCUITS

These circuits are used when polyphase power is available for the plate supply of a high-power transmitter. The circuit at B is also called a three-phase full-wave rectification system. The circuits are described in the accompanying text.

(or two-phase with Scott connection) energy. Several of the more common polyphase rectification circuits with their significant characteristics are shown in figure 8. The increase in ripple frequency and decrease in percentage of ripple is apparent from the figures given in figure 8. The circuit of figure 8C gives the best transformer utilization as does the bridge circuit in the single-phase connection. The circuit has the further advantage that there is no average d-c flow in the transformer, so that three single-phase transformers may be used. A tap at half-voltage may be taken at the junction of the star transformers, but there will be d-c flow in the transformer secondaries with the power-supply center tap in use. The circuit of figure 8A has the disadvantage that there is an average d-c flow in each of the windings.

Rectifiers Rectifying elements in high-voltage plate supplies are usually electron tubes of either the high-vacuum or mercury-vapor type, although silicon rectifier stacks containing a large number of elements are often used. Low-voltage high-current supplies may use argon gas rectifiers (Tungar tubes), silicon rectifiers, or other types of solid-state rectification elements.

Peak Inverse Plate Voltage and Peak Plate Current In an a-c circuit, the maximum peak voltage or current is $\sqrt{2}$, or 1.41 times that indicated by the a-c meters in the circuit. The meters read the *root mean square* (rms) values, which are the peak values divided by 1.41 for a sine wave.

If a potential of 1000 rms volts is obtained from a high voltage secondary winding of a transformer, there will be 1410 volts peak potential from the rectifier plate to ground. In a single-phase supply the rectifier tube has this voltage impressed on it, either positively when the current flows or "inverse" when the current is blocked on the other half-cycle. The *inverse peak voltage* which the tube will stand safely is used as a rating for rectifier tubes. At higher voltages the tube is liable to arc back, thereby destroying or damaging it. The

relations between peak inverse voltage, total transformer voltage, and filter output voltage depend on the characteristics of the filter and rectifier circuits (whether full- or half-wave, bridge, single-phase or polyphase, etc.).

Rectifier tubes are also rated in terms of *peak plate current*. The actual direct load current which can be drawn from a given rectifier tube or tubes depends on the type of filter circuit. A full-wave rectifier with capacitor input passes a peak current several times the direct load current.

In a filter with choke input, the peak current is not much greater than the load current if the inductance of the choke is fairly high (assuming full-wave rectification).

Mercury-Vapor Rectifier Tubes The inexpensive *mercury-vapor* type of rectifier tube is often used in the high-voltage plate supplies of amateur and commercial transmitters. Most amateurs are quite familiar with the use of these tubes but it should be pointed out that when new or long-unused mercury-vapor tubes are first placed in service, the filaments should be operated at normal temperature for approximately twenty minutes before plate voltage is applied, in order to remove all traces of mercury from the cathode and to clear any mercury deposits from the top of the envelope. After this preliminary warm-up with a new tube, plate voltage may be applied within 20 to 30 seconds after the time the filaments are turned on, each time the power supply is used. If plate voltage should be applied before the filament is brought to full temperature, active material may be knocked from the oxide-coated filament and the life of the tube will be greatly shortened.

Small r-f chokes must sometimes be connected in series with the plate leads of mercury-vapor rectifier tubes in order to prevent the generation of radio-frequency hash. These r-f chokes must be wound with sufficiently heavy wire to carry the load current and must have enough inductance to attenuate the r-f parasitic noise current to prevent it from flowing in the filter supply leads and then being radiated into nearby

receivers. Manufactured mercury-vapor rectifier hash chokes are available in various current ratings from various manufacturers.

When mercury-vapor rectifier tubes are operated in parallel in a power supply, small resistors or small iron-core choke coils should be connected in series with the plate lead of each tube. These resistors or inductors tend to create an equal division of plate current between parallel tubes and prevent one tube from carrying the major portion of the current. When high-vacuum rectifiers are operated in parallel, these chokes or resistors are not required.

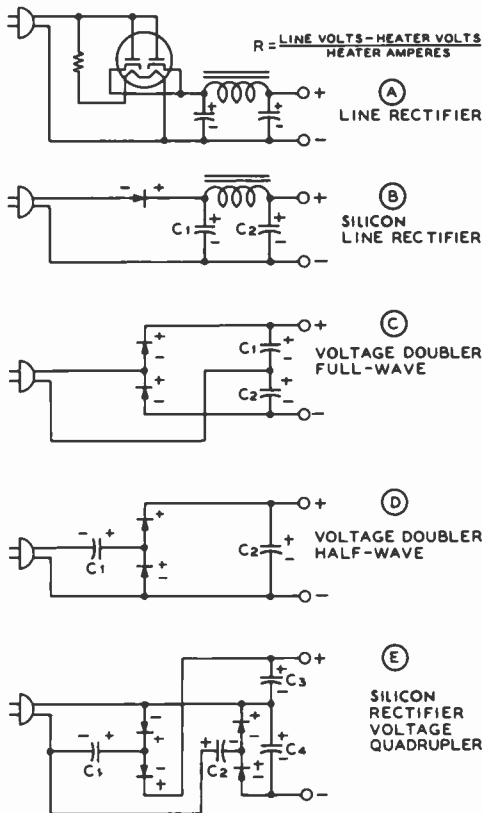

Figure 9

TRANSFORMERLESS POWER-SUPPLY CIRCUITS

Circuits such as shown above are also frequently called line-rectifier circuits. Silicon rectifiers, vacuum diodes, or gas diodes may be used as the rectifying elements in these circuits.

Transformerless Power Supplies Figure 9 shows a group of five different types of transformerless power supplies

which are operated directly from the a-c line. When circuits such as shown in A and B are operated directly from the a-c line, the rectifier element simply rectifies the line voltage and delivers the alternate half cycles of energy to the filter network. The d-c voltage output of the filter will be slightly less than the rms line voltage, depending on the particular type of rectifier employed. With the introduction of the miniature silicon rectifier, the transformerless power supply has become a very convenient source of moderate voltage at currents up to perhaps 500 ma. A number of advantages are offered by the silicon rectifier as compared to the vacuum-tube rectifier. Outstanding among these are the factors that the silicon rectifier operates instantly, and that it requires no heater power in order to obtain emission. The amount of heat developed by the silicon rectifier is very much less than that produced by an equivalent vacuum-tube type of rectifier.

In the circuits of figure 9 A, B, and C, capacitors C₁ and C₂ should be rated at approximately 150 volts, and for a normal degree of filtering and capacitance, should be between 15 to 60 μfd. In the circuit of figure 9D, capacitor C₁ should be rated at 150 volts and capacitor C₂ should be rated at 300 volts. In the circuit of figure 9E, capacitors C₁ and C₂ should be rated at 150 volts and C₃ and C₄ should be rated at 300 volts.

The d-c output voltage of the line rectifier may be stabilized by means of a VR tube. However, due to the unusually low internal resistance of the silicon rectifier, transformerless power supplies using this type of rectifying element can normally be expected to give very good regulation.

Voltage-Doubler Circuits Figures 9C and 9D illustrate two simple voltage-doubler circuits which will

deliver a d-c output voltage equal approximately to twice the rms value of the power line voltage. The no-load d-c output voltage is equal to 2.82 times the rms line voltage value. At high current levels, the output

voltage will be slightly under twice the line voltage. The circuit of figure 9C is of advantage when the lowest level of ripple is required from the power supply, since its ripple frequency is equal to twice the line frequency. The circuit of figure 9D is of advantage when it is desired to use the grounded side of the a-c line in a permanent installation as the return circuit for the power supply. However, with the circuit of figure 9C the ripple frequency is the same as the a-c line frequency.

Voltage Quadrupler The circuit of figure 9E illustrates a voltage-quadrupler circuit for miniature silicon rectifiers. In effect this circuit is equivalent to two voltage doublers of the type shown in figure 9D with their outputs connected in series. The circuit delivers a d-c output voltage under light load approximately equal to four times the rms value of the line voltage. The no-load d-c output voltage delivered by the quadrupler is equal to 5.66 times the rms line-voltage value and the output voltage decreases rather rapidly as the load current is increased.

30-4 The Silicon Rectifier

Silicon Rectifier Of all recent developments in the field of semiconductors, *silicon rectifiers* offer the most promising range of applications; from extreme cold to high temperature, and from a few watts of output power to very high voltage and currents. Inherent characteristics of silicon allow junction temperatures in the order of 200°C before the material exhibits intrinsic properties. This extends the operating range of silicon devices beyond that of any other efficient semiconductor and the excellent thermal range coupled with very small size per watt of output power make silicon rectifiers applicable where other rectifiers were previously considered impractical.

Silicon Current Density The current density of a silicon rectifier is very high, and on present designs ranges from 600 to 900 amperes per square inch of effective barrier layer. The usable

current density depends on the general construction of the unit and the ability of the heat sink to conduct heat from the crystal. The small size of the crystal is illustrated by the fact that a rectifier rated at 15 d-c amperes, and 150 amperes peak surge current has a total cell volume of only .00023 inch. Peak currents are extremely critical because the small mass of the cell will heat instantaneously and could reach failure temperatures within a time lapse of microseconds. The assembly of a typical silicon cell is shown in figure 10.

Operating Characteristics The *reverse direction* of a silicon rectifier is characterized by extremely high resistance, up to 10^9 ohms below a critical voltage point. This point of *avalanche voltage* is the region of a sharp break in the resistance curve, followed by rapidly decreasing resistance (figure 11A). In practice, the peak inverse working voltage is usually set at least 20% below the avalanche point to provide a safety factor.

A limited reverse current, usually of the order of 0.5 ma or less flows through the silicon diode during the inverse-voltage cycle. The reverse current is relatively constant to the avalanche point, increasing rapidly as this reverse-voltage limit is passed. The maximum reverse current increases as

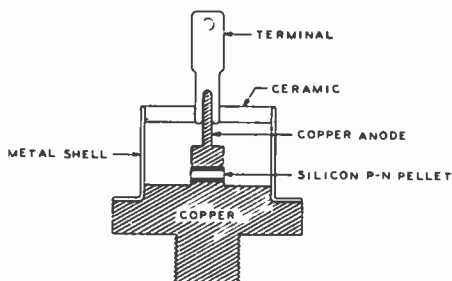

Figure 10

SILICON RECTIFIER

Silicon pellet is soldered to copper stud to provide low thermal resistance path between PN junction and heat sink. Copper anode is soldered to top of junction. Temperature of junction must be held to less than 200°C, as a result of increasing temperature on reverse current flow through junction.

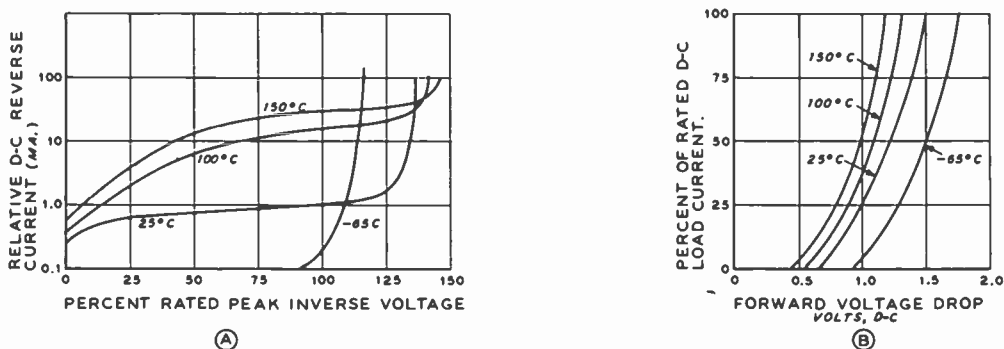

Figure 11

SILICON RECTIFIER CHARACTERISTICS

- A**—Reverse direction of silicon rectifier is characterized by extremely high resistance up to point of avalanche voltage.
- B**—Threshold voltage of silicon cell is about 0.6 volt. Once device starts conducting the current increases exponentially with small increments of voltage, then nearly linearly on a very steep slope.

diode temperature rises and, at the same time, the avalanche point drops, leading to a "runaway" reverse-current condition at high temperatures which can destroy the diode.

The forward characteristic, or resistance to the flow of forward current, determines the majority of power lost within the diode at operating temperatures. Figure 11B shows the static forward current characteristic relative to the forward voltage drop for a typical silicon diode. A small forward bias (a function of junction temperature) is required for conduction. The power loss of a typical diode rated at 0.5 ampere average forward current and operating at 100°C, for example, is about 0.6 watt during the conducting portion of the cycle. The forward voltage drop of silicon power rectifiers is carefully controlled to limit the heat dissipation in the junction.

Diode Ratings and Terms Silicon diodes are rated in terms similar to those used for vacuum-tube rectifiers.

Some of the more important terms and their definitions follow: *Peak Inverse Voltage* (PIV). The maximum reverse voltage that may be applied to a specific diode type before the avalanche breakdown point is reached.

Maximum RMS Input Voltage—The maximum rms voltage that may be applied to a specific diode type for a resistive or inductive load. The PIV across the diode may be greater than the applied rms voltage in the case of a capacitive load and the maximum rms input voltage rating must be reduced accordingly.

Maximum Average Forward Current—The maximum value of average current allowed to flow in the forward direction for a specified junction temperature. This value is specified for a resistive load.

Peak Recurrent Forward Current—The maximum repetitive instantaneous forward current permitted to flow under stated conditions. This value is usually specified for 60 Hz and a specific junction temperature.

Maximum Single-Cycle Surge Current—The maximum one-cycle surge current of a 60-Hz sine wave at a specific junction temperature. Surge currents generally occur when the diode-equipped power supply is first turned on, or when unusual voltage transients are introduced in the supply line.

Derated Forward Current—The value of direct current that may be passed through a diode for a given ambient temperature. For higher temperatures, less current is allowed through the diode.

Maximum Reverse Current—The maximum leakage current that flows when the diode is biased to the peak-inverse voltage.

Silicon diodes may be mounted on a conducting surface termed a *heat sink* that, because of its large area and heat dissipating ability, can readily dispose of heat generated in the diode junction, thereby safeguarding the diode against damage by excessive temperature.

Diode Noise The silicon diode, widely used in power supplies, exhibits a forward-conduction characteristic as shown in figure 11B. The diode does not conduct until the applied forward potential exceeds the threshold voltage, which is about 0.5 volt. At this voltage the diode conducts abruptly, creating a steep wavefront, capable of generating radio-frequency interference. The interference is often eliminated if a transient suppression capacitor is placed across the diode (figure 12). In some cases, especially with the use of controlled-avalanche diodes, the capacitor is omitted and the *white-noise* interference generated by the diode may be found as an annoying "rush" on the sidebands of the transmitted signal, or as an annoying noise in the receiver. Suppression capacitors and additional lead filtering in the power supply may be required to eliminate the interference created by the abrupt conduction characteristic of the diode rectifier.

30-5 Series Diode Operation

Series diode operation is commonly used when the peak-inverse voltage of the source is greater than the maximum PIV rating of a single diode. For proper series operation, it is important that the PIV be equally divided among the individual diodes. If it is not, one or more of the diodes in the *stack* will be subjected to a PIV greater than its maximum rating and, as a result, may be destroyed. As most failures of this type result in a shorted junction, the PIV on the remaining diodes in the stack is raised, making each diode subject to a greater value of PIV. Failure of a single diode in a stack can lead to a "domino effect" which will destroy the

remaining diodes if care is not taken to prevent this disaster. Forced voltage distribution in a stack is necessary when the individual diodes vary appreciably in reverse characteristics. To equalize the steady-state voltage division, shunt resistors may be placed across the diodes in a stack (figure 12A). The maximum value of the shunt resistor to achieve a 10-percent voltage balance, or better is:

$$\text{Shunt resistance} = \frac{\text{PIV}}{2 \times \text{Max. Reverse Current}}$$

Six-hundred-volt PIV diodes, for example, having a reverse current of 0.3 ma at the maximum PIV require a shunt resistance of 1 megohm, or less.

Transient Protection Diodes must be protected from voltage transients which often are many times greater than

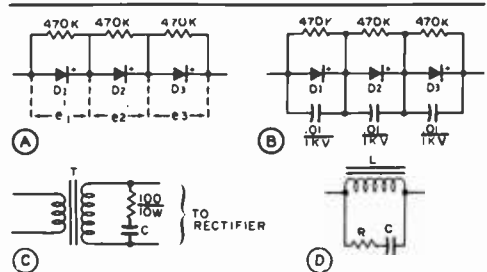

Figure 12

PROTECTION CIRCUITS FOR SEMICONDUCTOR POWER SUPPLIES

- A—Peak inverse voltage should be distributed equally between series-connected diodes. If diodes do not have matched reverse characteristics, shunt resistors should be placed across the diodes.
- B—Series-connected diodes are protected against high-voltage switching transients by shunt capacitors which equalize and absorb the transients uniformly along the stack.
- C—Transient suppressor placed across the secondary of the high-voltage transformer protects diode stack from transients often found on the a-c power line or created by abrupt change in the magnetizing current of the power transformer.
- D—Suppressor network across series filter choke absorbs portion of energy released when magnetic field of choke collapses, thus preventing the surge current from destroying the diode stack.

the permissible peak-inverse voltage. Transients can be caused by d-c switching at the load, by transformer switching, or by shock excitation of LC circuits in the power supply or load. Shunt capacitors placed across the diodes will equalize and absorb the transients uniformly along the stack (figure 12B). The shunt capacitor should have at least 100 times the capacitance of the diode junction, and capacitance values of 0.01 μfd or greater are commonly found in diode stacks used in equipment designed for amateur service.

Controlled avalanche diodes having matched zener characteristics at the avalanche point usually do not require RC shunt suppressors, reducing power-supply cost and increasing over-all reliability of the rectifier circuit.

In high-voltage stacks, it is prudent to provide transient protection in the form of an RC suppressor placed across the secondary of the power transformer (figure 12C). The suppressor provides a low-impedance path for high-voltage transients often found on a-c power lines, or generated by an abrupt change in the magnetizing current of the power transformer as a result of switching primary voltage or the load. The approximate value of the surge capacitor in such a network is:

$$\text{Capacitance } (\mu\text{fd}) = \frac{15 \times E \times I}{e^2}$$

where,

- E is the d-c supply voltage,
- I is the maximum output current of the supply in amperes,
- e is the rms voltage of the transformer secondary winding.

High-voltage transients can also be caused by series filter chokes subject to abrupt load changes. An RC suppressor network placed across the winding of the choke can absorb a portion of the energy released when the magnetic field of the choke collapses, thus preventing the current surge from destroying the diode stack (figure 12D). The approximate value of the transient capacitor is:

$$\text{Capacitance } (\mu\text{fd}) = \frac{L \times I^2}{10 \times E^2}$$

where,

- L is the maximum choke inductance (henrys),
- I is the maximum current passing through the choke (amperes),
- E is the maximum d-c supply voltage.

The resistance in series with the capacitor should equal the load impedance placed across the supply.

30-6 Silicon Supplies for SSB

Shown in figure 13 are three semiconductor power supplies. *Circuit A* provides 500 volts (balanced to ground) at 0.5 ampere. If the supply is isolated from ground by a 1:1 transformer of 250 watts capacity *point A* may be grounded and *point B* will provide half-voltage. *Circuit B* is a half-wave tripler that delivers 440 volts at 0.5 ampere. In this circuit, one side of the power line is common to the negative side of the output. *Circuit C* is a 900-watt, 0.5 ampere supply composed of two voltage doublers supplied from a "distribution" transformer having dual 117/240-volt windings.

Power Supply Rating The *duty cycle* (ratio of duration of maximum power output to total "on" time) of a power supply in SSB and c-w service is much smaller than that of a supply used for a-m equipment. While the power supply must be capable of supplying peak power equal to the PEP input of the SSB equipment for a short duration, the average power demanded by SSB voice gear over a period of time usually runs about one-half or less of the PEP requirement. Then, too, the intervals between words in SSB operation provide periods of low duty, just as the spaces in c-w transmission allow the power supply to "rest" during a transmission. Generally speaking, the average power capability of a power supply designed for *intermittent voice service* (IVS) can be as low as 25 percent of the PEP level. C-w requirements run

somewhat higher than this, the average c-w power level running close to 50 percent of the peak level for short transmissions. Relatively small power transformers of modest capability may be used for intermittent voice and c-w service at a worthwhile saving in weight and cost. The power capability of a transformer may be judged by its weight, as shown in the graph of figure 16. It must be remembered that the use of alc or voice compression in SSB service raises the duty, thus reducing the advantage of the IVS power rating. The IVS rating is difficult to apply to very small power transformers, since the d-c resistance of the transformer windings tends to degrade the voltage regulation to a point where the IVS rating is meaningless. Intelligent use of the IVS rating in choosing a power transformer, stacked silicon rectifiers, and "computer" type electrolytic capacitors can permit the design and construction of inexpensive, lightweight

high-voltage power supplies suitable for SSB and c-w service.

The Design of IVS Power Supplies

The low duty of SSB and c-w modes can be used to advantage in the design of high-voltage power supplies for these services.

The Power Transformer — Relatively low-voltage transformers may be used in voltage-doubler service to provide a kilowatt or two of peak power at potentials ranging from one to three thousand volts. Most suitable power transformers are rated for commercial service and the IVS rating must be determined by experiment. Figure 14 shows a relationship between various services as determined by extensive tests performed on typical transformers. The data illustrates the relationship between transformer weight and power capability. Transformer weight excludes weight of the

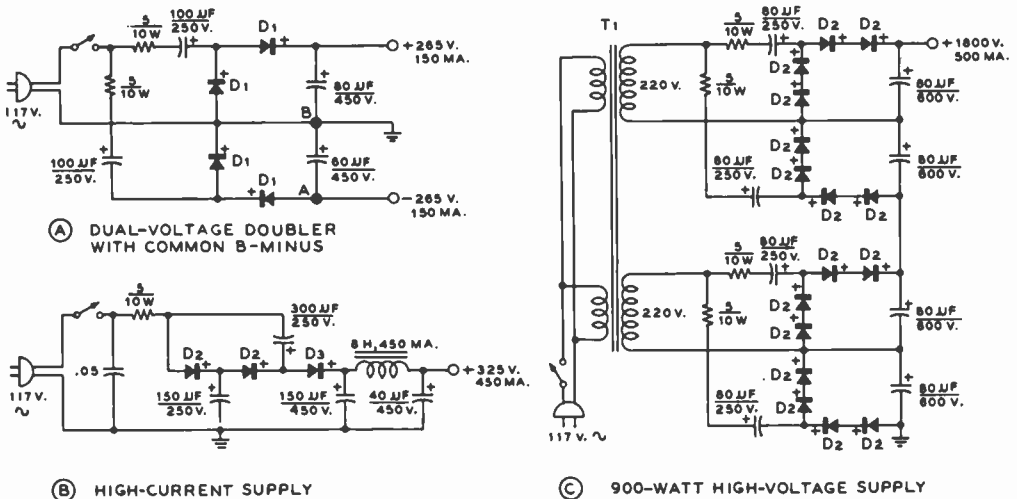

Figure 13

SEMICONDUCTOR POWER SUPPLIES

- A—Voltage-quadrupler circuit. If point "A" is taken as ground instead of point "B," supply will deliver 530 volts at 150 ma from 117-volt a-c line. Supply is "hot" to line.
- B—Voltage tripler delivers 325 volts at 450 ma. Supply is "hot" to line.
- C—900-watt supply for sideband service may be made from two voltage quadruplers working in series from inexpensive "distribution-type" transformer. Supply features good dynamic voltage regulation.
- D₁, D₂, D₃—1N4005. Use .01-µfd capacitor and 100K resistor across each diode.
- T₁—Power distribution transformer, used backwards. 240/460 primary, 117/240 secondary, 0.75 KVA. Chicago PCB-24750.

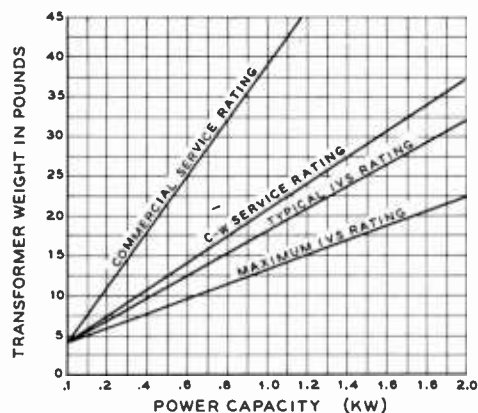

Figure 14

INTERMITTENT VOICE SERVICE IN SSB PERMITS LARGE PEAK POWER TO BE DRAWN FROM POWER TRANSFORMER. PEAK-TO-AVERAGE RATIO OF NEARLY FOUR TO ONE MAY BE ACHIEVED WITH MAXIMUM IVS RATING. POWER CAPACITY OF TRANSFORMER MAY BE DETERMINED FROM WEIGHT

case and mounting fixtures. Thus, a plate transformer weighing about 17 pounds that is rated for 400 watts commercial or industrial service should have an 800-watt peak capacity for c-w service and a 950-watt peak capacity for intermittent SSB service. A transformer having a so-called "two-kilowatt PEP" rating for sideband may weigh as little as 22 pounds, according to this graph.

Not shown in the graph is the effect of amplifier idling (standby) current taken from the supply, or the effect of bleeder current. Both currents impose an extra, continuous drain on the power transformer and quickly degrade the IVS rating of the transformer. Accordingly, the IVS curves of figure 14 are limited to the bleeder current required by the equalizing resistors for a series capacitor filter and assume that the idling plate current of the amplifier is cut to only a few milliamperes by the use of a VOX-controlled cathode bias system. If the idling plate current of the amplifier assumes an appreciable fraction of the peak plate current, the power capability of the supply decreases to that given for c-w service.

Most small power transformers work reliably with the center tap of the secondary winding above ground potential. Some of the larger transformers, however, are designed to have the center tap grounded and lack sufficient insulation at this point to permit their use in either a bridge or voltage doubling configuration. The only way of determining if the center-tap insulation is sufficient is to use the transformer and see if the insulation breaks down at this point! It is wise to ground the frame of the transformer so that if breakdown occurs, the frame of the transformer does not assume the potential of the secondary winding and thus present a shock hazard to the operator.

The Silicon Rectifier—A bewildering variety of "TV-type" silicon rectifiers exists and new types are being added daily. Generally speaking, 600-volt PIV rectifiers, having an average rectified current rating of 1 ampere at an ambient temperature of 75°C with a maximum single-cycle surge-current rating of 15 amperes or better are suitable for use in the power supplies described in this section. Typical rectifiers are packaged in the *top-hat* configuration as well as the epoxy-encapsulated assembly and either type costs less than a dollar per unit. In addition, *potted* stacks utilizing controlled-avalanche rectifiers are available at a cost less than that of building a complete RC stack of diodes. The silicon rectifier, if properly used, is rarely the limiting factor in the design of steady-state IVS power supplies, provided proper transient protection is incorporated in the supply.

The Filter Capacitor—Recently developed "computer"-type aluminum-foil electrolytic capacitors combine high capacitance per unit of volume with moderate working voltage at a low price. Capacitors of this type can withstand short-interval voltage surges of 15 percent over their d-c working voltage. In a stack, the capacitors should be protected by voltage-equalizing resistors, as shown in the power supplies in this section. The capacitors are sheathed in a *Mylar* jacket and may be mounted on the chassis or adjacent to each other without additional insulation between the units. The stack may be taped and mounted to a metal

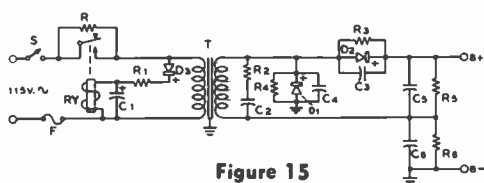

Figure 15

INRUSH CURRENT PROTECTION FOR POWER SUPPLY

Charging current of capacitor filter may be limited by series impedance of the power supply. In voltage-doubler circuit shown here, primary resistor R limits inrush current to within the capability of the diodes. Limiting resistor is shorted out after sufficient time has elapsed to partially charge the filter capacitors. Delay time of 0.5 second is usually sufficient. R_1 - C_1 combination determines time delay. Secondary surge suppression (R_2 - C_2) is used, and shunt RC equalizing networks are employed across each diode stack. Filter capacitors (C_3 , C_4) are "computer-grade" electrolytic capacitors in series with 10K, 10-watt wirewound resistor placed across each capacitor.

chassis with a metal clamp, as is done in some of the units described here.

Inrush Current Protection — When the power supply is first turned on, the filter capacitors are discharged and present a near short circuit to the power transformer and rectifier stack. The charging current of a high-capacitance stack may exceed the maximum peak-recurrent current rating of the rectifiers for several cycles, thus damaging the diodes. Charging current is limited only by the series impedance of the power-supply circuit which consists mainly of the d-c circuit resistance (primarily the resistance of the secondary winding of the power transformer) plus the leakage reactance of the transformer. Transformers having high secondary resistance and sufficient leakage reactance usually limit the inrush current so that additional inrush protection is unnecessary. This is not the case with larger transformers having low secondary resistance and low leakage reactance. To be on the safe side, in any case, it is good practice to limit inrush current to well within the capability of the diode stack. A current-limiting circuit is shown in figure 15 which can be added at little expense to any power supply. The current-limiting resistor (R) is initially in the

circuit when the power supply is turned on, but is shorted out by relay RY after a sufficient time has elapsed to partially charge the filter capacitors of the power supply. The relay coil is in a simple time-delay circuit composed of R_1 - C_1 . The delay may be adjusted by varying the capacitance value, and need only be about one-half second or so. Surplus 24-volt d-c relays used in dynamotor starting circuits work well in this device, as they have large low-resistance contacts and reasonable coil resistance (250 ohms or so).

Practical IVS Supplies An IVS voltage-doubler power supply may be designed with the aid of figures 14 and 16.

A typical doubler circuit, such as shown in figure 15 is to be used. The full-wave voltage doubler is preferred over the half-wave type, as the former charges the filter capacitors in parallel and discharges them in series to obtain a higher d-c voltage than the peak voltage of the secondary winding of the power transformer. This saves transformer weight and expense.

Referring to figure 15, filter capacitors C_5 and C_6 are charged on alternate half cycles, but since the capacitors are in series across the load, the ripple frequency has twice the line frequency.

A second advantage of the full-wave doubler over the half-wave type is that the former tends to be self-protecting against switching transients. One diode stack is always in a conducting mode, regardless of the polarity of a transient, and the transient is therefore discharged into the filter-capacitor stack.

The filter-capacitor stack is rated for the peak no-load voltage (plus a safety factor), while the diode rectifiers must be able to withstand twice the peak no-load voltage (plus a safety factor). Good engineering practice calls for the *d-c working voltage of each portion* of the capacitor stack to be equal to the peak a-c voltage of the power transformer ($1.41 \times$ rms secondary voltage) plus 15 percent safety factor.

The R' Factor—The a-c secondary voltage, secondary resistance, circuit reactance, and IVS capability of a transformer will

determine its excellence in voltage-doubler service. The end effect of these parameters may be expressed by an empirical R' factor as shown in figure 16. As an example, assume a power transformer is at hand weighing 25 pounds, with a secondary winding of 840 volts (rms) and a d-c secondary resistance of 8 ohms. The IVS rating of this transformer (from figure 14) is about 1.5 kW, PEP, or more. The appropriate d-c no-load voltage of an IVS supply making use of this unit in voltage-doubler service, such as the circuit of figure 15, is:

$$E_{NO\ LOAD} = 2.81 \times e$$

where,

e is the rms secondary voltage.

For this transformer, then, the no-load d-c supply voltage is about 2360 volts. The full load voltage will be somewhat less than this value. For a maximum power capability of 1.5 kW, a full-load current of about 0.75 ampere is required if the full load d-c voltage is in the vicinity of 2000. This is a realistic figure, so a "target" full-load voltage of 2000 is hopefully chosen.

The projected full-load voltage for a doubler-type supply may be determined with the aid of the R' factor and is calculated from:

$$E_{LOAD} = E_{NO\ LOAD} - R' (I \times R)$$

where,

R' is determined from figure 16,

I is the full load current in amperes,

R is the secondary resistance of the transformer.

For this example, R' is about 60 for the secondary resistance of 8 ohms, and the full-load d-c voltage of the supply is found to be just about 2000.

The peak rectified voltage across the complete filter-capacitor stack is equal to the no-load d-c voltage and is 2360 volts. Six 450-volt "computer"-type 240- μ fd electrolytic capacitors in series provide a 40- μ fd effective capacitor, with a working voltage of 2700 (peak voltage rating of 3000), a sufficient margin for safety. Each capacitor is shunted with two 100K, 2-watt resistors in parallel.

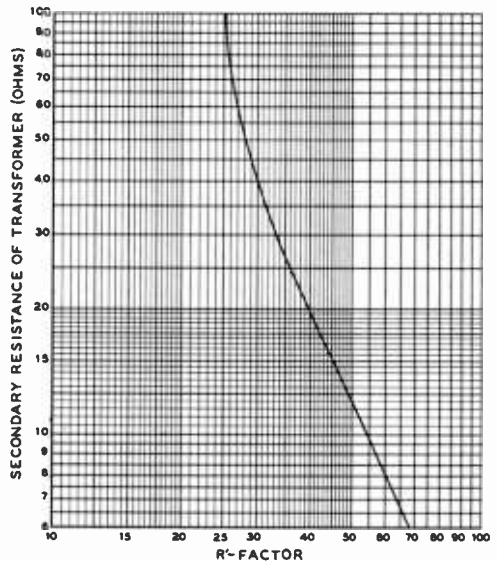

Figure 16

R' FACTOR GRAPH FOR IVS POWER SUPPLIES

The full load d-c voltage of an IVS-rated voltage-doubler power supply may be determined with the aid of this graph. The secondary resistance of the transformer is measured and the R' Factor is found. For example, a transformer having a secondary resistance of 20 ohms has an R' factor of about 40. The factor is used in formula 7 to calculate the full load d-c voltage of the power supply. For use with bridge circuits, the R' factor derived here should be divided by 2.5 before being used in the formula.

The total PIV for the diode stack is twice the peak rectified voltage and is 4720 volts. A 100-percent safety factor is recommended for the complete stack, whose PIV should thus be about 9440 volts. The number of individual diodes in a suitable stack is:

$$\text{Number of diodes} = \frac{11.2 \times \text{rms voltage}}{\text{Diode PIV}}$$

For this example, 600-volt PIV rectifiers are chosen and 16 are required, eight in each half of the stack.

The charging current of the capacitor stack may be safely ignored if the power supply is energized through a series primary resistor (R) such as shown in figure 15. One-ampere diodes having a single-cycle surge-current rating of 15 to 30 amperes are recommended for general use. The dif-

fused silicon rectifiers (1N3195 and 1N4005, for example) have a single-cycle surge-current rating of 30 amperes and are no more expensive than the older style alloy junction rectifiers (1N547 and 1N1492, for example) having a much lower single-cycle surge current rating.

Capacitor Filters Power supplies for SSB service whose current requirements have a large peak-to-average ratio often make use of capacitor filters (figure 17). This simple circuit eliminates the resonant transients that are often found in LC filter systems and, if the capacitance is sufficiently large, provides adequate voltage regulation. In the case of a 2-kW PEP supply (2500 volts at 0.8 ampere) the load resistance is 3100 ohms and the required capacitance for 5-percent regulation is 55 μ fd. Dynamic regulation of this degree is satisfactory for SSB and c-w service, as well as for amplitude modulation. As discussed earlier, the rectifier and power transformer must be protected from the inrush charging current of the filter capacitor.

30-7 A 1-Kilowatt IVS Power Supply

Shown in figures 18 and 19 is a typical 1-kilowatt IVS power supply designed from

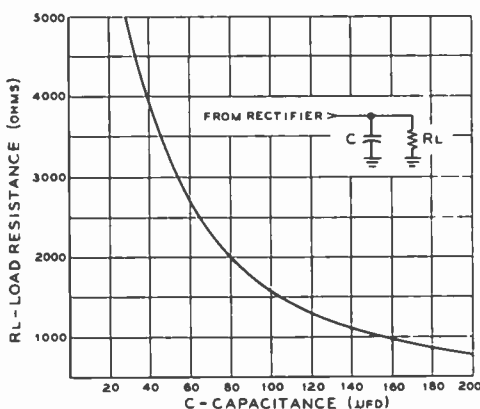

Figure 17

CAPACITOR FILTER

Capacitor filter is often used for SSB linear-amplifier power supplies. For 5-percent regulation, chart shows capacitance required for various values of d-c plate-load resistance.

the above data. This supply is based on a 40-percent duty cycle and may be used for c-w service at 1-kilowatt level, or up to 1200 watts PEP or so for SSB service. The regulation of the supply is shown in the graph (figure 19), and the unit is capable of delivering 2300 volts at 0.5 ampere in IVS operation. The no-load voltage rises to 2750. The power supply is suitable for running a single 3-400Z at maximum rating, or it may be used for a pair of 813, 4CX250B, or 4CX300A tubes at the kilowatt level. A transformer having less secondary resistance and slightly less secondary voltage would provide improved voltage regulation. The 840-volt transformer having an 8-ohm secondary winding discussed earlier would be ideal in this application.

The power supply is constructed on a steel amplifier foundation chassis and dust cover. The diode stack is mounted on a perforated phenolic board under the chassis. The electrolytic capacitors are taped together and held in position atop the chassis by a clamp cut from an aluminum sheet. The interior of the clamp is lined with a piece of plastic material salvaged from a package of frozen vegetables. The voltage-equalizing resistors are wired across the terminals of the capacitors. Normally, it takes 10 seconds or so to fully discharge the filter capacitors when no external load is connected to the supply. It is recommended that the supply be discharged with a 1000-ohm, 100-watt resistor before any work is done on the unit. Power-supply components and all terminals should be well protected against accidental contact. The voltage delivered by this supply is lethal and the filter capacitors hold a considerable charge for a surprising length of time. This is the price one pays for an intermittent-duty design, and care should be exercised in the use of this equipment.

To reduce the standby current and power consumption, it is recommended that cathode bias be applied to the linear amplifier stage shown in various designs in this Handbook. During transmission, the cathode resistor may be shorted out by contacts of the VOX relay, restoring the stage to proper operation.

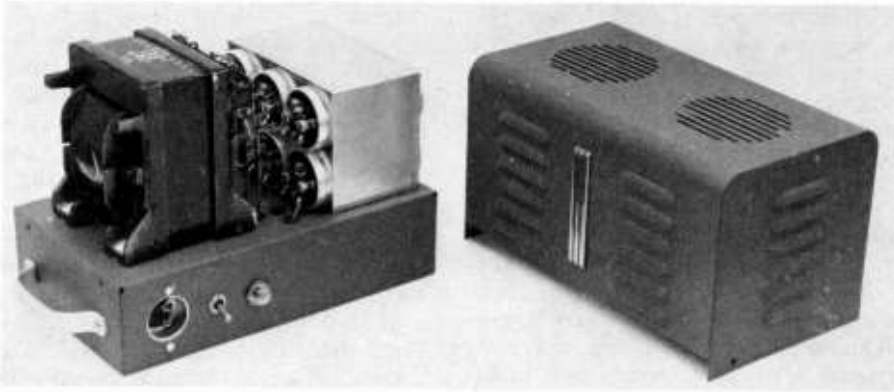

Figure 18

COMPACT ONE-KILOWATT IVS SUPPLY FOR SSB AND C-W SERVICE

This power supply delivers 2250 volts at 500 ma for SSB operation and 2400 volts at 400 ma for c-w operation. The supply is constructed on a covered foundation unit measuring 12" X 7" X 9" high (Bud CA-1751). The electrolytic capacitors are held in position by a bracket cut from aluminum sheet. Primary power receptacle, power switch, and neon pilot light are on the front apron of the chassis, with primary fuse and Miller high-voltage connector on the rear apron. High-voltage diode stack is mounted beneath the chassis on a phenolic board.

Using the alternative 1100-volt transformer, the supply delivers 2600 volts at a c-w rating of 380 ma. Peak IVS voice rating is 500 ma (1.25 KW, PEP). No-load voltage is about 3100, and eight electrolytic capacitors are required in the stack instead of six.

30-8 A 2-Kilowatt PEP Supply for SSB

The power supply described in this section is designed for the maximum power rating for amateur service. It is capable of 1.2 kilowatts power for c-w (50 percent duty cycle) and 2 kilowatts IVS for SSB service. The supply is ideally suited for a grounded-grid amplifier using a single 3-1000Z, 4-1000A, or a pair of 3-400Z's. Regulation of the supply is shown in figure 21. A voltmeter is incorporated in the supply to monitor the plate voltage at all times. The supply makes use of the circuit of figure 17. Twenty 600-volt PIV diodes are used in the rectifier stack to provide a total PIV of 12 KV, which allows an ample safety factor. Eight 240- μ fd, 450-volt capacitors are used in the filter stack to provide 30-

μ fd effective capacitance at 3600 volts working voltage. The voltage across the "bottom" capacitor in the stack is monitored by a 0-to-1 d-c milliammeter recalibrated 0 to 4 KV and which is used with a series multiplier to provide a 0 to 5000-volt full-scale indication. A 0-to-1 d-c ammeter is placed in series with the negative lead to the high-voltage terminal strip.

The supply is built on a steel amplifier foundation chassis in the same style as the 1-kW supply described previously. All safety precautions outlined earlier should be observed with this supply.

30-9 IVS Bridge-Rectifier Supplies

The bridge-rectifier circuit is somewhat more efficient than the full-wave circuit in that the former provides more direct current per unit of rms transformer current for a given load than does the full-wave circuit. Since there are two rectifiers in opposite arms of the bridge in the conducting mode when the a-c voltage is at its peak value, the remaining two rectifiers are back-biased to the peak value of the a-c voltage. Thus

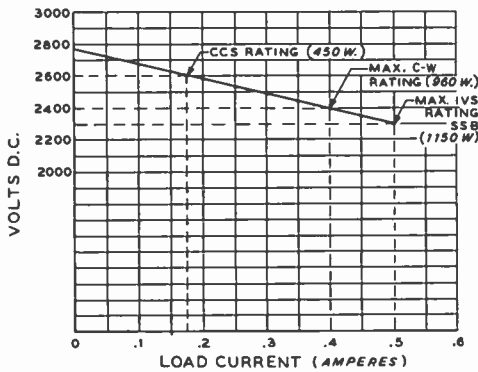

Figure 19

REGULATION CURVE OF ONE KILOWATT IVS SUPPLY

The power supply uses the circuit of figure 15. Primary surge resistor (R) is 5 ohms, 50 watts. Secondary surge-voltage resistor (R_s) is 200 ohms, 10 watts. Surge capacitor (C_s) is .02 μfd, 3 KV (Aerovox P89-M). Sixteen type 1N2071 (600-volt PIV) diodes are used in an assembly such as shown in figures 25 and 26. The diode shunt capacitors are .01-μfd, 600-volt ceramic discs, and the shunt resistors are 470K, 1/2-watt units. Six 450-volt (working), 240-μfd filter capacitors are used in series, each capacitor shunted with two 100K, 2-watt resistors in parallel. The time delay relay (RY) has a 24-volt d-c coil with a resistance of about 280 ohms (Potter-Brumfield PR5-DY). Contacts are rated at 25 amperes. Delay time is about 0.5 second and is determined primarily by the time constant of R_s-C_s. Suggested values are 800 μfd (50 working volts) for C, and 600 ohms, 10 watts for R_s. Diode D₁ may be a 1N2070. The power transformer shown is a surplus unit having a 115/230-volt primary and a 960-volt secondary. The transformer weight is 18 pounds and it has an IVS rating of 1.2 KW. (A commercial alternative is Hill Magnetics Co., 2201 Bay Road, Redwood City, Calif. #HMP-1939A. This compact, 825-volt, wound-core transformer has improved regulation and is rated at 1 KW continuous duty [2 KW IVS rating] and provides 2000 volts at a continuous load of 500 ma.)

the bridge-rectifier circuit requires only half the PIV rating for the rectifiers as compared to a center-tap full-wave rectifier. The latter circuit applies the sum of the peak a-c voltage plus the stored capacitor voltage to one rectifier arm in the maximum inverse-voltage condition.

A 500-Watt IVS Bridge Power Supply Shown in figure 22 is a 500-watt bridge power supply designed

around an inexpensive "TV-replacement" type power transformer. The secondary winding is 1200 volts center-tapped at a current rating of 200 ma. The weight of the transformer is 8 pounds, and the maximum IVS rating is about 500 watts or so. Secondary resistance is 100 ohms. Used in bridge service, the transformer makes practical an inexpensive power supply providing about 1250 volts at an IVS peak current rating of 380 ma. The no-load voltage is about 1600. For c-w use, the current rating is 225 ma at 1400 volts (about 300 watts). Maximum PIV is nearly 1700 volts so each arm of the bridge must withstand this

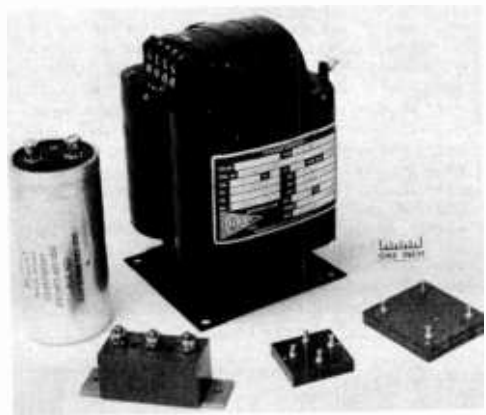

Figure 20

COMPACT COMPONENTS FOR MODERN POWER SUPPLIES

Recent developments in compact components allow construction of ultracompact power supplies of unusually great capability. In foreground are three controlled-avalanche rectifier modules that take the place of power rectifiers and their accompanying filament transformer. At left is voltage-doubler module that provides 3000 volts d.c. at 1 ampere. Center: Bridge rectifier module for rms input voltages up to 1400 at a load current of 1.5 ampere. Right: Bridge-rectifier module for rms input voltages up to 10,000 at a load current of 1.5 ampere. Because of controlled-avalanche characteristic of these modules, no surge network is necessary across individual diodes of the module.

At the left is a 240-μfd, 450-volt "computer-type" electrolytic capacitor suitable for stacking in high-voltage power supplies (Mallory type CG). The power transformer (rear) has a wound, hypersil core and provides 2000 volts d.c. at 500 ma (continuous service) in a doubler configuration. (Hill Magnetics, Inc., Redwood City, Calif.)

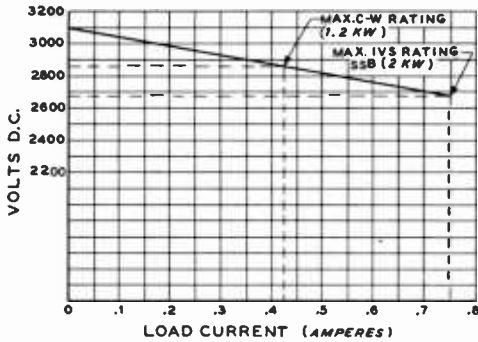

Figure 21

REGULATION CURVE OF 2-KILOWATT IVS SUPPLY

The power supply uses the circuit of figure 15. Surge components are as given in figure 19, except that the surge capacitor (C_s) has a rating of 5 kV. Twenty type-1N2071 (600-volt PIV) diodes are used in an assembly similar to that shown in figures 24 and 25. Eight 240 μ fd, 450-working-volt (500-volt peak) capacitors are used to provide 30 μ fd effective capacitance. Two 100K, 2-watt resistors are shunted across each capacitor. Time-delay circuit components are as suggested in figure 15. The transformer used has a 117/240-volt primary and an 1100-volt secondary, with an ICAS rating of 1.2 kW. (Berkshire Transformer Corp., Kent, Conn. #BTC-4905B).

value. Allowing a 100-percent safety factor requires 3400 volts PIV per arm, which may be made up of six 600-volt PIV diodes in series with an appropriate RC network across each diode. The diode assembly is constructed on two phenolic boards, one of which is shown in figures 24 and 25. A total of 24 rectifiers are required. Four 120- μ fd, 450-volt electrolytic capacitors in series provide 30 μ fd at a working voltage of 1800. The negative of the supply is above ground by virtue of the 10-ohm, 10-watt resistor which permits plate-current metering in the negative power lead while the supply and amplifier remain at the same ground potential.

This supply is designed for use with two 811A's in grounded-grid service. The tubes are biased to plate-current cutoff in standby mode by a cathode resistor which is shorted out by contacts on the push-to-talk or VOX circuitry. The power supply is built in an inclosed amplifier cabinet, similar to the one shown in figure 18. The B-plus lead is made of a length of RG-8/U coaxial cable, used in conjunction with a high-voltage coaxial connector.

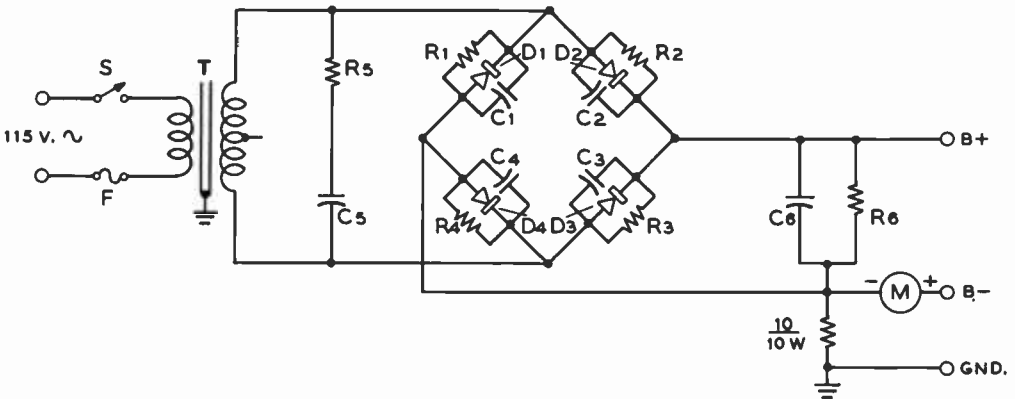

Figure 22

SCHEMATIC OF 500-WATT IVS BRIDGE POWER SUPPLY

Diode package (C_1 - D_1 - R_1 , etc.) is composed of one each: 1N2071 diode in parallel with .01 μ fd, 600-volt ceramic capacitor and a 470K, 1/2-watt resistor. Each bridge arm requires six packages, made as shown in figures 24 and 25. The secondary voltage-surge network (C_1 - R_1) is a 100-ohm, 10-watt resistor in series with a .02 μ fd, 3 kV capacitor (Aerovox PB9-M). The power transformer has a 1200-volt center tapped 200-ma rating. (Stancor PC-8414 or Thordarson 22R36). The filter stack uses four 120- μ fd, 450-volt electrolytic capacitors in series, with 10K, 10-watt resistors across each capacitor. Meter (M) is a 0-500 d-c milliammeter. A 10-ampere fuse (F) is used. Transformer core is grounded as a safety measure.

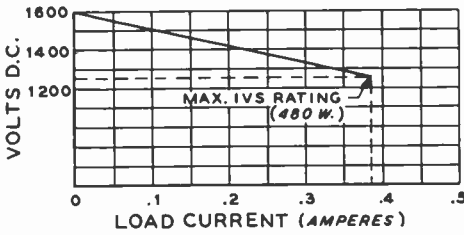

Figure 23

VOLTAGE-REGULATION CURVE OF 500-WATT BRIDGE POWER SUPPLY

30-10 Regulated Power Supplies

Voltage-Regulator Tubes A voltage-regulator tube (VR tube) is a gaseous device which maintains a constant voltage across its electrodes under conditions of varying current. A number of tube types are available which stabilize the voltage across their terminals at 75, 90, 105,

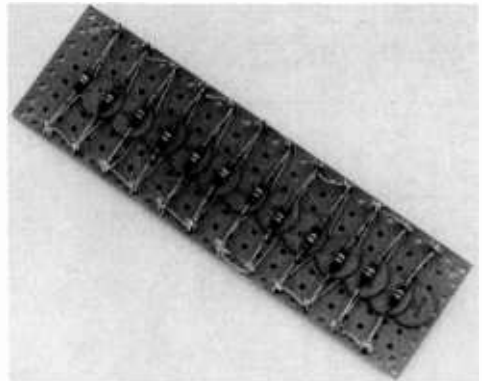

Figure 25

REAR VIEW OF HIGH-VOLTAGE DIODE STACK

The shunt capacitors and resistors are mounted on the rear of the phenolic board. Each diode-resistor-capacitor package has an individual pair of mounting terminals, which are jumpered together to connect the diodes in series. This arrangement provides greatest available heat sink for the components. The assembly is mounted an inch or so away from the chassis by means of 4-40 machine screws and ceramic insulators placed in corners of the board.

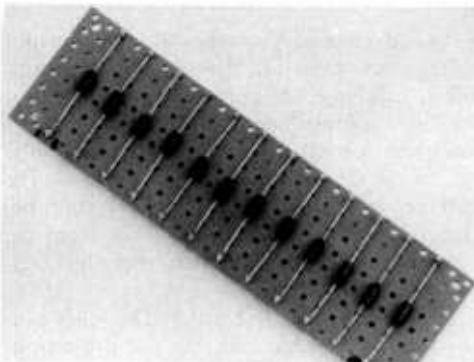

Figure 24

ASSEMBLY OF HIGH-VOLTAGE DIODE STACK

Inexpensive "TV-type" diodes may be connected in series to provide a high value of peak-inverse voltage. Shown here are twelve type-1N2071 diodes mounted on a Vector-board (64AA32 cut to size). The diodes are soldered to Vector terminals (T9.6) mounted in the prepunched holes in the phenolic board. A pair of long-nose pliers should be used as a heat sink when soldering the diode leads. Grasp the diode lead between the diode body and the joint, permitting the pliers to absorb the soldering heat.

or 150 volts. The regulator tube is connected in series with a current-limiting resistor of such value that will permit the regulator tube to draw from 8 to 40 ma under normal operating conditions. The tube must be supplied from a potential source that is higher than the starting, or ignition voltage of the tube (figure 26). Regulator-tube currents greater than 40 ma will shorten the life of the tube and currents lower than 5 ma or so will result in unstable regulation. A voltage excess of about 15 percent is required to ignite the tube and this is usually taken care of by the no-load voltage rise of the source supply.

The value of the limiting resistor must permit minimum tube current to flow, and at the same time allow maximum regulator-tube current to flow under conditions of no load current, as shown in the illustration.

When a VR tube is to be used to regulate the voltage applied to a circuit drawing less than 15 ma normal or average current, the simplest method of adjusting the series resistance is to remove the load and vary the

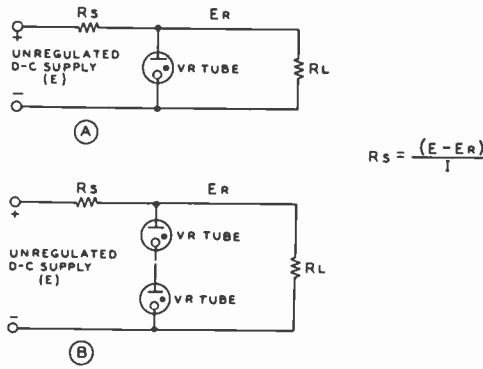

Figure 26

VOLTAGE-REGULATOR TUBE CIRCUITS

- A—Single regulator tube stabilizes voltage at discrete intervals between 90 and 300 volts.
- B—Series-connected tubes offer stabilization up to 300 volts. Series resistor (R_s) is a function of supply voltage (E) and regulated voltage (E_R).

series resistor until the VR tube draws about 40 ma. Then connect the load, and that is all there is to it. This method is particularly recommended when the load is a heater-type vacuum tube, which may not draw current for several seconds after the power supply is turned on. Under these conditions, the current through the VR tube will never exceed 40 ma even when it is running unloaded (while the heater tube is warming up and the power-supply rectifier has already reached operating temperature).

Electronic Regulation Voltage regulation may be accomplished by the use of *series control tube* and a voltage sensing and comparison circuit, as shown in figure 27. The series tube must be capable of dissipating power represented by the difference between the input voltage from the supply and the output voltage from the regulator at the maximum current flow to the load. In many cases, tubes are operated in parallel to obtain the required plate dissipation. The output voltage of the electronically regulated supply may be changed over a wide range by varying the grid voltage of the d-c amplifier tube. The reference voltage may be supplied from a battery or voltage-regulator tube.

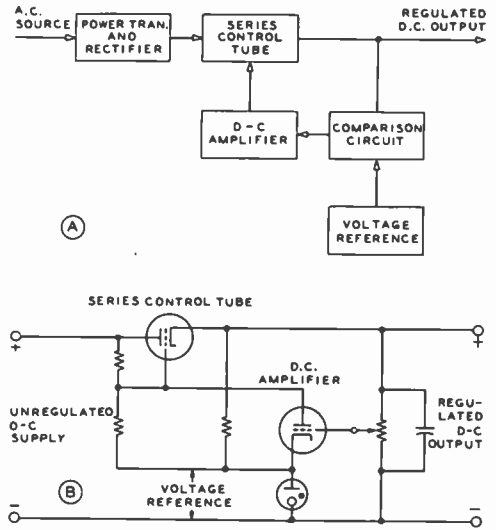

Figure 27

SERIES-REGULATED D-C POWER SUPPLY

D-c amplifier compares the output voltage of power supply to a voltage reference source. Voltage drop through series control tube is adjusted to balance circuit, providing voltage regulation of 1% or better

The d-c amplifier compares the output voltage to that of the reference source. When the output voltage drops, the d-c amplifier is unbalanced and the tube draws less plate current, thus raising the grid voltage on the series-connected control tube. The voltage drop through the control tube becomes less and the output voltage from the supply is raised, compensating for the original voltage reduction.

Practical electronic regulated supplies usually employ tetrode tubes in the d-c amplifier for higher amplifier gain and low- μ series control tubes for better control of regulation, providing regulation of the order of plus or minus 1 percent or so.

A 400-Volt Regulated Supply This heavy-duty regulated power supply provides regulated voltage over the range of 325 to 450 volts. Above 400 volts, the maximum current rating is 250 ma.

A 6AS7G is employed as the series control element, and type-816 mercury-vapor rectifiers are used in the power supply section. The 6AS7G acts as a variable series resist-

ance which is controlled by a separate regulator tube much in the manner of avc circuits or inverse feedback as used in receivers and a-f amplifiers. A 6SH7 controls the operating bias on the 6AS7G, and therefore controls the internal resistance of the 6AS7G. This, in turn, controls the output voltage of the supply, which controls the plate current of the 6SH7, thus completing the cycle of regulation. It is apparent that under these conditions any change in the output voltage will tend to "resist itself," much as the avc system of a receiver resists any change in signal strength delivered to the detector.

Because it is necessary that there always be a moderate voltage drop through the 6AS7G in order for it to have proper control, the rest of the power supply is designed to deliver as much output voltage as possible. This calls for a low-resistance full-wave rectifier, a high-capacitance output capacitor in the filter system and a low-resistance choke.

Reference voltage in the power supply is obtained from a VR150 gaseous regulator. Note that the 6.3-volt heater winding for the 6SH7 and the 6AS7G tubes is operated at a potential of plus 150 volts by connecting the winding to the plate of the VR150. This procedure causes the heater-cathode voltage of the 6SH7 to be zero, and permits an output voltage of up to 450 since the 300-volt heater-to-cathode rating of the 6AS7G is not exceeded with an output voltage of 450 from the power supply.

If the power supply is to be used with an output voltage of 400 to 450 volts, the full 615 volts each side of center should be applied to the 816's. However, the maximum plate dissipation rating of the 6AS7G will be exceeded, due to the voltage drop across the tube, if the full current rating of 250 ma is used with an output voltage below 400 volts. If the power supply is to be used with full output current at voltages below 400 volts the 520-volt taps on the plate transformer should be connected to the 816's. Some variation in the output range of the power supply may be obtained by varying the values of the resistors and the potentiometer across the output. However, be sure that the total plate dissipation rating

of 26 watts of the 6AS7G series regulator is not exceeded at maximum current output from the supply. The total dissipation in the 6AS7G is equal to the current through it (output current plus the current passing through the two bleeder strings) multiplied by the drop through the tube (voltage across the filter capacitor minus the output voltage of the supply).

A Shunt-Regulated Bias Supply Many of the popular class-B modulator and grounded-grid linear amplifier tubes require a few volts of well-regulated negative bias. Shown in figure 29 is an electronic bias supply which will provide a regulated bias voltage variable over the range of 20 to 80 volts. Regulation is 0.001 volt/ma, which is remarkable for a supply as simple as this. Between 30 and 80 volts, the supply will regulate grid current up to 200 ma. Be-

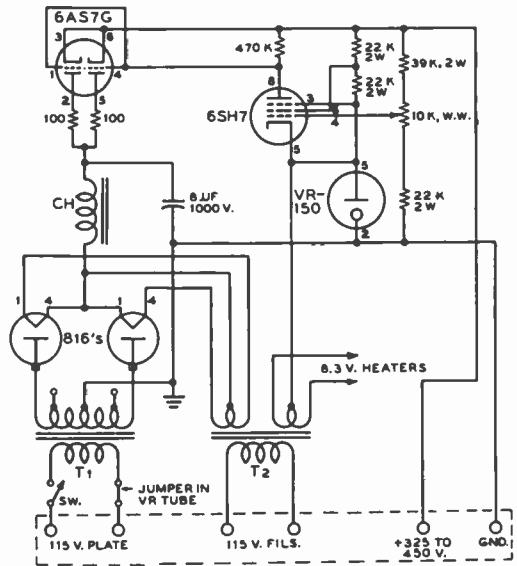

Figure 28

SCHEMATIC OF VOLTAGE-REGULATED POWER SUPPLY

- T₁—615 or 520 volts each side of c.t., 300 ma. Stancor P-8041
- T₂—5 volts at 3 amp., 6.3 volts at 6 amp. Stancor P-5009
- CH—4-henry at 250 ma. Stancor C-1412

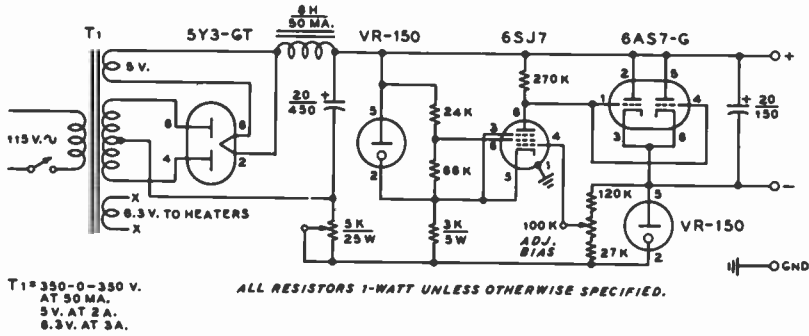

Figure 29

SCHEMATIC, LOW-VOLTAGE REGULATED BIAS SUPPLY

tween 20 and 30 volts, maximum grid current is restricted to 100 ma.

Basically, the regulated supply consists of a small power supply which delivers plate voltage to a low- μ 6AS7G triode. The voltage drop across the triode is used as the regulated bias voltage. Associated with the triode is a d-c amplifier and a voltage-regulator tube which serves to vary the grid voltage of the triode regulator tube so that a constant voltage is maintained across it. The 5K variable potentiometer is adjusted to produce about 20 ma current through the first regulator tube.

well suited to this task. The unit delivers 250 volts at 60 ma and may be controlled down to 150 volts, at which point the maximum current is limited to 40 ma. A single 6JZ8 *Compactron* tube serves as a series regulator and d-c amplifier. A small NE-2 neon lamp connected in the cathode circuit of the triode section of the 6JZ8 provides reference voltage and may be used as a pilot light.

30-11 General-Purpose Power Supplies

A Low-Voltage Regulated Supply (150 to 250 volts)

A stable, voltage-regulated power supply is a useful adjunct to the experimenter's workshop for use with receivers, test equipment, and other devices requiring controlled voltage. Shown in figure 30 is a small power supply that is

well suited to this task. The unit delivers 250 volts at 60 ma and may be controlled down to 150 volts, at which point the maximum current is limited to 40 ma. A single 6JZ8 *Compactron* tube serves as a series regulator and d-c amplifier. A small NE-2 neon lamp connected in the cathode circuit of the triode section of the 6JZ8 provides reference voltage and may be used as a pilot light.

Power supplies may either be of the choke-input type illustrated in figure 31, or the capacitor-input type, illustrated in figure 32. Capacitor-input filter systems are characterized by a d-c supply output voltage that runs from 0.9 to about 1.3 times the rms voltage of one-half of the high-voltage sec-

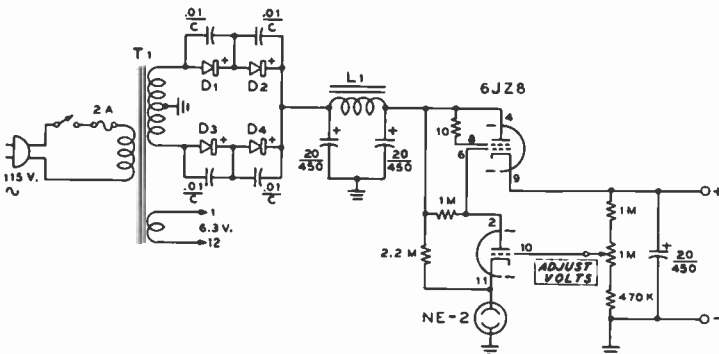
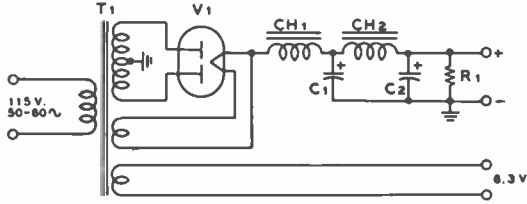

Figure 30

LOW-VOLTAGE REGULATED SUPPLY

D₁ thru D₄—IN4005 or equivalent
T₁—480 volts, c.t. at 70 ma, 6.3 volts at 3 amps
L₁—8 henrys, 75 ma



COMPONENTS						APPROXIMATE OUTPUT VOLTAGE		MAX. CURRENT	6.3 V. FILAMENT	
T ₁	V ₁	CH ₁	CH ₂	C ₁	C ₂	R ₁	NO LOAD			FULL LOAD
350-0-350 STANCOR PC-8409	5Y3-GT	10 H. STANCOR C-1001	10 H. STANCOR C-1001	10 μF, 450 V. CORNELL- DUBILIER BR-1045	20 μF, 450 V. CORNELL- DUBILIER BR-2045	35K,10W	310	240	80 MA.	3 A.
375-0-375 STANCOR PC-8411	5Y3-GT	3-13 H. STANCOR C-1718	7 H. STANCOR C-1421	10 μF, 450 V. CORNELL- DUBILIER BR-1045	20 μF, 450 V. CORNELL- DUBILIER BR-2045	35K,10W	330	230	140 MA.	4.5 A.
400-0-400 STANCOR PC-8413	5U4-G	2-12 H. STANCOR C-1402	4 H. STANCOR C-1412	10 μF, 450 V. CORNELL- DUBILIER BR-1045	10 μF, 450 V. CORNELL- DUBILIER BR-1045	35K,10W	360	270	250 MA.	3 A.
525-0-525 UTC S-40	5U4-G8	5-25 H. UTC S-32	20 H. UTC S-31	10 μF, 600V. MALLORY TC-92	10 μF, 600 V. MALLORY TC-92	35K,10W	480	375	240 MA.	4 A.
600-0-600 UTC S-41	5R4-GY	5-25 H. UTC S-32	20 H. UTC S-31	8 μF, 600 V. SPRAGUE CR-88	8 μF, 600 V. SPRAGUE CR-88	35K,25W	540	410	200 MA.	4 A.
900-0-900 UTC S-45	5R4-GY	5-25 H. UTC S-32	20 H. UTC S-31	4 μF, 1KV. SPRAGUE CA-41	8 μF, 1KV. SPRAGUE CA-81	50K,25W	830	650	175 MA.	—

Figure 31

DESIGN CHART FOR CHOKE-INPUT POWER SUPPLIES

Full wave solid-state rectifier may be substituted for V₁, providing improved voltage regulation.

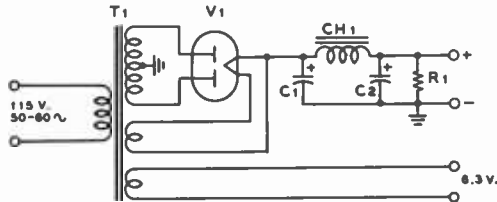

COMPONENTS						APPROXIMATE OUTPUT VOLTAGE		MAX. CURRENT	6.3 V. FILAMENT
T ₁	V ₁	CH ₁	C ₁	C ₂	R ₁	NO LOAD	FULL LOAD		
280-0-280 STANCOR PC-8404	5Y3-GT	10 H. STANCOR C-1001	20 μF, 450 V. CORNELL- DUBILIER BR-2045	20 μF, 450 V. CORNELL- DUBILIER BR-2045	35K,10W	340	240	80 MA.	3 A.
375-0-375 STANCOR PC-8411	5Y3-GT	7 H. STANCOR C-1421	10 μF, 600 V. MALLORY TC-92	10 μF, 600 V. MALLORY TC-92	35K,10W	480	350	125 MA.	4.5 A.
435-0-435	5U4-G	4 H. STANCOR C-1412	8 μF, 600 V. SPRAGUE CR-88	8 μF, 600 V. SPRAGUE CR-88	35K,25W	800	400	225 MA.	6 A.
600-0-600 STANCOR PC-8414	5R4-GY	4 H. STANCOR C-1412	4 μF, 1KV. SPRAGUE CA-41	8 μF, 1KV. SPRAGUE CA-81	50K,25W	800	800	200 MA.	6 A.
900-0-900 UTC S-45	3R4-GY	20 H. UTC S-31	4 μF, 1.5KV. SPRAGUE CA-415	8 μF, 1.5KV. SPRAGUE CA-815	75K 25W	1200	910	150 MA.	—

Figure 32

DESIGN CHART FOR CAPACITOR-INPUT POWER SUPPLIES

Full wave solid-state rectifier may be substituted for V₁, providing improved voltage regulation

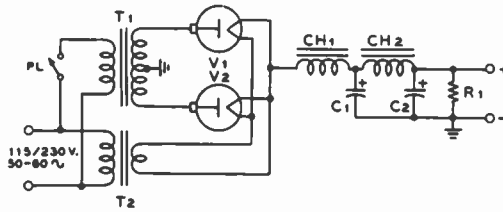

COMPONENTS								APPROXIMATE OUTPUT VOLTAGE		MAX. CURRENT (ICAS)
T ₁	T ₂	V ₁ -V ₂	CH ₁	CH ₂	C ₁	C ₂	R ₁	NO LOAD	FULL LOAD	
1150-0-1150 CHICAGO TRANS. P-107	2.5V., 10A. CHI. TRAN. F-210	866-A 866-A	6H. CHI. TRAN. R-63	10H. CHI. TRAN. R-103	4UF, 1.5KV. SANGAMO 7115-4	8UF, 1.5KV. SANGAMO 7115-8	40K,75W	1150	1000	350 MA.
1710-0-1710 CHICAGO TRANS. P-1512	2.5V., 10A. CHI. TRAN. F-210H	866-A 866-A	6H. CHI. TRAN. R-65	10H. CHI. TRAN. R-105	4UF, 2KV. SANGAMO 7120-4	8UF, 2KV. SANGAMO 7120-8	50K,75W	1700	1500	425 MA.
2800-0-2800 CHICAGO TRANS. P-2126	5V., 10A. CHI. TRAN. F-310H	872-A 872-A	6H. CHI. TRAN. R-67	6H. CHI. TRAN. R-87	4UF, 3KV. SANGAMO 7130-4	4UF, 3KV. SANGAMO 7130-8	75K 200W	2750	2300	700 MA.
3500-0-3500 UTC C6-309	5V., 10A. UTC LS-62	872-A 872-A	10H. UTC C6-15	10H. UTC C6-15	4UF, 4KV. CORNELL- DUBILIER 740040-A	4UF, 4KV. CORNELL- DUBILIER 740040-A	100K 200W	3400	3000	1000 MA.
4800-0-4800 UTC C6-310 CHICAGO TRANS. P-4333	5V., 20A. UTC LS-63	373-A 373-A	10H. UTC C6-15	10H. UTC C6-15	4UF, 5KV. AEROVOX JP-09	4UF, 5KV. AEROVOX JP-09	100K 300W	4400	4000	800 MA.

Figure 33

DESIGN CHART FOR CHOKE-INPUT HIGH-VOLTAGE SUPPLIES

ondary winding of the transformer. Capacitor-input filter systems are not recommended for use with mercury-vapor rectifier tubes, as the peak rectifier current may run as high as five or six times the d-c load current of the power supply.

Choke-input filter systems are characterized by lower peak-load currents (1.1 to 1.3 times the average load current) than the capacitor-input filter, and by better voltage regulation. Design charts for capacitor and choke-input filter supplies for various voltages and load currents are shown in figures 31, 32, and 33.

The construction of power supplies for transmitters, receivers, and accessory equipment is a relatively simple matter electrically since lead lengths and placement of parts are of minor importance and since the circuits themselves are quite simple.

Bridge Supplies Some practical variations of the common bridge-rectifier circuit of figure 7 are illustrated in figure 34. In many instances a transmitter or modulator requires two different supply voltages, differing by a ratio of about 2:1. A simple bridge supply such as shown in figure 34

will provide both of these voltages from a simple broadcast "replacement-type" power transformer. It is to be noted that separate filament transformers are used for rectifier tubes V₁ and V₂, and that one leg of each filament is connected to the cathode of the respective tube, which is at a high potential with respect to ground. The choke CH₁ in the negative lead of the supply serves as a common filter choke for both output voltages. Each portion of the supply may be considered as having a choke-input filter system. Filaments of V₁ and V₂ are energized before the primary voltage is applied to T₁.

Bridge supplies may also be used to advantage to obtain relatively high plate voltages for high-powered transmitting equipment. Type 866A and 872A rectifier tubes will serve in supplies delivering up to 3500 volts in a full-wave circuit. Above this voltage, the peak inverse-voltage rating of the mercury-vapor tube will be exceeded, and danger of flashback within the tube will be present. However, with bridge circuits, the same tubes will deliver up to 7000 volts d.c. without exceeding the peak inverse-voltage rating.

The modern trend is to employ solid-state rectifiers in high-voltage circuits, as dis-

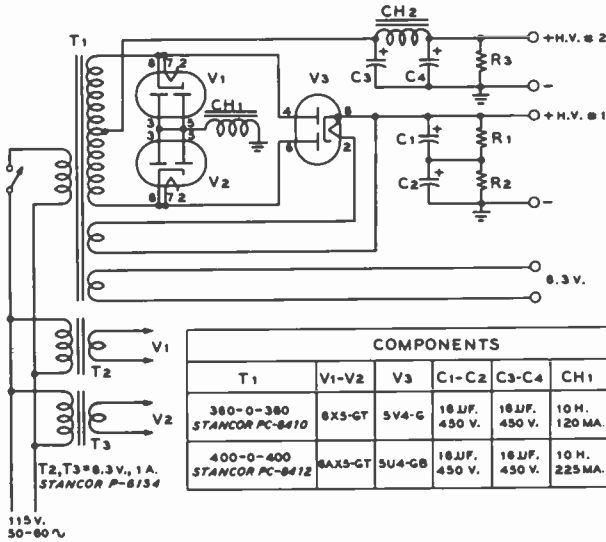

Figure 34
DUAL-VOLTAGE
INTERMITTENT-SERVICE
BRIDGE POWER SUPPLIES

COMPONENTS										FULL LOAD VOLT.		MAX. CURRENT	
T ₁	V ₁ -V ₂	V ₃	C ₁ -C ₂	C ₃ -C ₄	CH ₁	CH ₂	R ₁ -R ₂	R ₃	HV#1	HV#2	#1	#2	
380-0-380 STANCOR PC-8410	6X5-GT	5V4-G	18 J.F. 450 V.	18 J.F. 450 V.	10 H. 120 MA.	8 H. 50 MA.	20K,10W	100 K 1 W	800	240	80 MA.	40 MA.	
400-0-400 STANCOR PC-8412	8AX5-GT	5U4-GB	18 J.F. 450 V.	18 J.F. 450 V.	10 H. 225 MA.	8 H. 75 MA.	20K,10W	100 K 1 W	825	280	130 MA.	50 MA.	

cussed earlier, and special full-wave and bridge rectifiers may be obtained which are suitable for operation up to three or four thousand volts d-c output at currents in excess of one ampere.

Commercial plate transformers intended for full wave rectifier service may also be used in bridge service *provided* that the insulation at the center-tap point of the high-voltage winding is sufficient to withstand one-half of the rms voltage of the secondary winding. Many high-voltage transformers are specifically designed for operation with the center tap of the secondary winding at ground potential; consequently the insulation of the winding at this point is not designed to withstand high voltage. It is best to check with the manufacturer of the transformer and find out if the insulation will withstand the increased voltage before a full-wave type transformer is utilized in bridge-rectifier service.

Transistor Power Supplies Experimenters interested in solid-state circuitry have need of a low-voltage, well-filtered power supply that has low internal impedance. Shown in this section are two supplies designed for this type of service.

The simple regulated power supply shown in figure 35 will deliver a nominal 9 volts at a maximum current rating of 300 ma. Over the current range of zero to 300 ma, the output voltage of the supply varies from 9.5 to 8.5 volts. The supply incorporates transient and surge protection in addition to having a very low internal impedance. A 2N376A is used as a series regulator and a 1N960B is a zener diode which establishes reference bias for the transistor. A 1N2974B zener diode serves as a transient suppressor and is normally nonconducting.

Shown in figure 36 is a current-limited power supply that provides a nominal 10, 20, or 30 volts at a maximum current rating

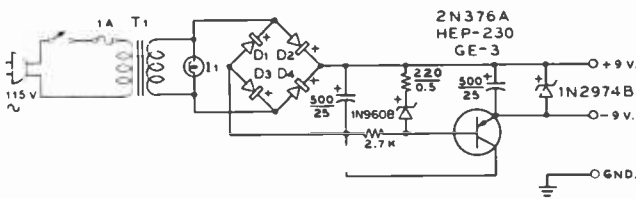

Figure 35
REGULATED 9-VOLT
POWER SUPPLY

T₁-12.6 volts, 1 amp
D₁ thru D₄-1N2482 or equivalent
L₁-12-volt pilot lamp consisting of style
Note: chassis used as heat sink for transistor.

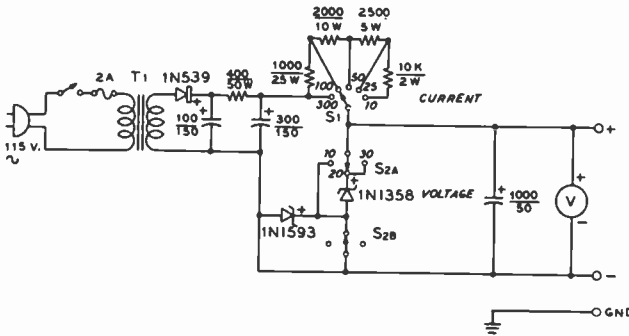

Figure 36

CURRENT-LIMITED
POWER SUPPLY

T_1 —117-117 volts, 35 watts.
Triad N-51X
Note: Zener diodes mounted
on 2-inch square aluminum
plates for heat sinks.

of 10, 25, 50, 100, or 300 milliamperes. Regulation is accomplished by interconnections of two zener reference diodes by means of voltage selector switch S_2 . Switch S_1 selects various values of series resistance which serve as current regulators. When the load current exceeds the limit selected by switch S_1 , the voltage drops below zener voltage and the supply acts as a constant-current source. The zener diodes should be mounted on 2-inch insulated heat sinks.

Transceiver Power Supplies Single-sideband transceivers require power supplies that provide several values of high voltage, bias voltage, filament voltage, and d-c control-circuit voltage. The supply may provide up to 600 watts of d-c power in intermittent voice service. The use of high-storage "computer"-type electrolytic capacitors permits maximum power to be maintained during voice peaks, while still permitting the power transformer to be operated within an average power rating of about 50-percent peak power capability, even for extended periods of time.

Two transceiver power supplies are shown in this section. The first is designed around a power transformer specially built for SSB service. The second supply is designed around a heavy-duty "TV replacement" type power transformer. The former supply is capable of a PEP power level of better than 600 watts, while the latter design is limited to about 300 watts PEP.

A schematic of the 600-watt PEP power supply is shown in figure 38. A multiple-winding transformer is used which has sufficient capacity to run the largest transceivers on a continuous voice-operated basis. The transformer weighs 16 pounds and has great reserve capacity. The power supply provides 800 volts at an intermittent current of 800 milliamperes, 250 volts at an intermittent current of 200 milliamperes, an adjustable bias voltage at a continuous current of 100 milliamperes, and either 6.3 volts or 12.6 volts filament supply at 12 or 6 amperes, respectively. An additional circuit provides 12 volts d.c. for operation of auxiliary VOX or switching relays. Controlled-avalanche diodes are used in the

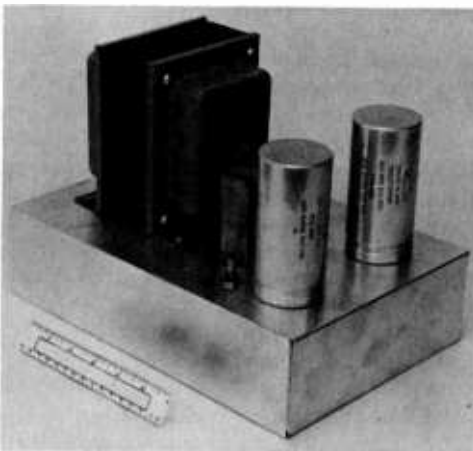

Figure 37

600-WATT IVS POWER SUPPLY
FOR SSB TRANSCEIVERS

Special transceiver power supply provides heavy-duty capacity to run largest of SSB transceivers. Power transformer and filter choke are to the left, with bias-adjustment potentiometer in foreground. Multiwire cable connects supply to transceiver. Semiconductor rectifiers are assembled as shown in figures 24 and 25 and placed beneath the chassis.

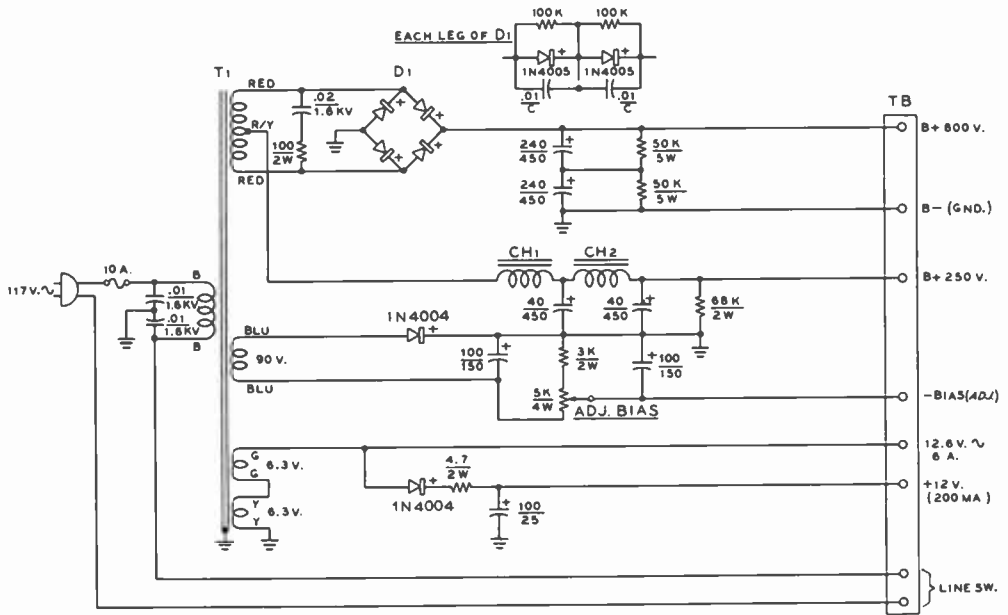

Figure 38

SCHEMATIC, 600-WATT TRANSCEIVER SUPPLY

T₁—600 volts, 400 ma; 250 volts, 100 ma; 6.3 volts, 6 amps; 6.3 volts, 6 amps, 117-volt primary.
Triad P-31A
CH₁—1 henry, 300 ma
CH₂—3 henrys, 300 ma

bridge-rectifier circuit, in conjunction with RC shunt networks and transient suppression across the power-supply secondary winding.

Additional transient protection is afforded by large bypass capacitors placed on the primary winding of the power transformer. The supply is actuated by a remote-power-line switch, usually located in the transceiver.

The construction of the supply is shown in figure 37. The aluminum chassis is small enough to fit within the speaker cabinet of the transceiver, and parts layout is not critical. The rectifier bridge is assembled on a phenolic board, in the manner shown in figures 24 and 25 and mounted below the chassis in a clear area. The filter capacitors are mounted to a phenolic board, their terminals protruding into the under-chassis area.

All voltage connections are terminated on a connector strip, and a single power cable may be run from the power supply to the

transceiver. The leads carrying the filament voltage should be doubled up, using two wires for each lead to reduce voltage drop within the cable to a minimum. The 6.3-volt filament windings of the transformer may be arranged in either series or parallel configuration, according to the requirements of the transceiver.

Complete filter-capacitor discharge takes about 10 seconds once the supply is turned off, and it is recommended that the capacitor stack be shorted with a 1000-ohm 100-watt resistor before any work is done on the supply.

An inexpensive utility power supply may be constructed about a "TV replacement" transformer, using auxiliary transformers, as needed, for filament and bias supplies, as shown in figure 39. The filament voltage is stepped up to 117 volts by a reverse-connected filament transformer (*T₂*) and is rectified to provide adjustable bias voltage. The power supply delivers 600 to 750 volts

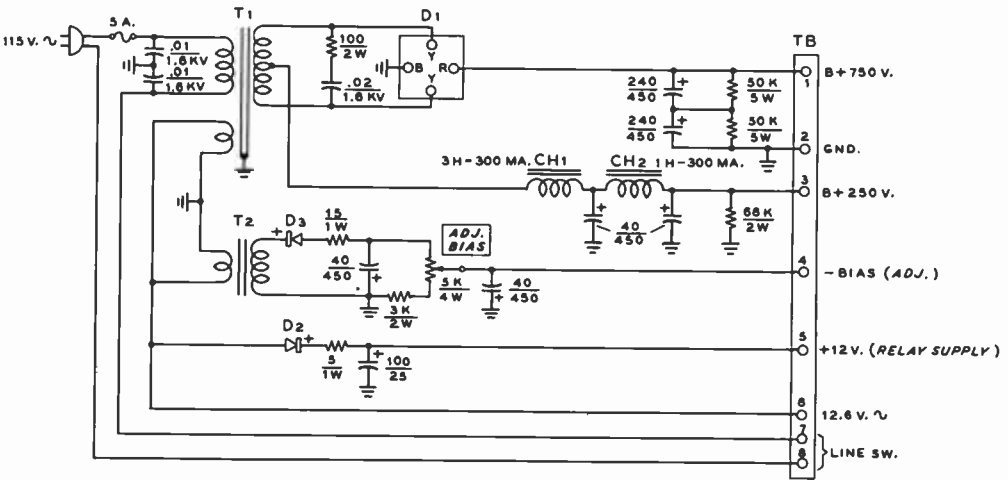

Figure 39
SCHEMATIC, 300-WATT IVS TRANSCEIVER POWER SUPPLY

Various replacement power transformers may be used with this power supply. Suggested units are: (1) 650-volt c.t. at 225 ma.; 12.6-volt at 5.25 amp. (Stancor P-8339), for 650-volt d-c output. (2) 750-volt c.t. at 325 ma.; 12.6 volt at 6.0 amp. (Stancor P-8365), for 750-volt d-c output. (3) 540-volt c.t. at 260 ma.; 6.3-volt at 8.8 amp. (Stancor P-8356), for 600-volt d-c output and 6.3 volt filament supply.

Transformer T, 6.3 volts at 1 amp. (Stancor P-8389). CH₁: 3 henrys at 300 ma (Stancor C-2334). CH₂: 1 henry at 300 ma (Stancor C-2343). D₁: Diode bridge, 1400-volt rms, 1.5 amp (2000-volt PIV). Diodes Inc. #BR-820A. D₂: 1N2070.

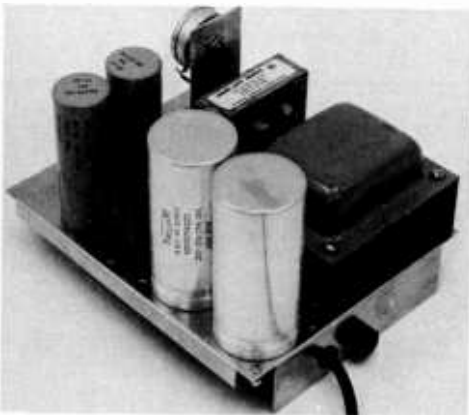

Figure 40
300-WATT IVS POWER SUPPLY
FOR SSB TRANSCEIVERS

This compact IVS-rated power supply provides all operating voltages necessary to operate most popular 55B transceivers. The supply uses a "TV-replacement" power transformer in conjunction with a bridge-rectifier circuit. The unit is designed to be placed in the speaker cabinet of the transceiver, and the chassis should be shaped to custom-fit the particular speaker cabinet in use. If desired, the supply may be built on a chassis with a dust cover and placed beneath the station console.

The power transformer is to the left, with the 240-µfd, 450-volt filter capacitors in the foreground. The capacitors are mounted to a phenolic plate which is bolted to the chassis. The two filter chokes are to the rear, along with the low-voltage filter capacitors and the "adjust-bias" potentiometer. The reverse-connected filament transformer is at the rear of the chassis. Semiconductor rectifiers are placed beneath the chassis.

at 400 milliamperes peak current, and about 250 volts at 200 milliamperes peak current. Depending on choice of power transformer, either 6.3- or 12.6-volt filament supply may be provided, in addition to low-voltage d.c.

for operation of VOX or control relays. Layout of the supply is shown in figure 40. The unit is constructed on a home-made aluminum chassis contoured to fit within a speaker cabinet.

Electronic Test Equipment

All amateur stations are required by law to have certain items of test equipment available within the station. A c-w station is required to have a frequency meter or other means, in addition to the transmitter frequency control, for ensuring that the transmitted signal is on a frequency within one of the frequency bands assigned for such use. A phone station is required in addition to have a means of determining that the transmitter is not being modulated in excess of its modulation capability, and in the case of an a-m transmitter, not more than 100 percent. Further, any station operating with a d-c power input greater than 900 watts is required to have a means of determining the exact input to the final stage of the transmitter, so as to ensure that the d-c power input to the plate circuit of the output stage does not exceed 1000 watts.

The additional test and measurement equipment required by a station will be determined by the type of operation contemplated. It is desirable that all stations have an accurately calibrated voltohmmeter for routine transmitter and receiver checking and as an assistance in getting new pieces of equipment into operation. An oscilloscope and an audio oscillator make a very desirable adjunct to a phone station using a-m

or f-m transmission, and are a necessity if single-sideband operation is contemplated. A calibrated signal generator is almost a necessity if much receiver work is contemplated, although a frequency meter of LM or BC-221 type, particularly if it includes internal modulation, will serve in place of the signal generator. Extensive antenna work invariably requires the use of some type of standing-wave meter. Lastly, if much construction work is to be done, a simple grid-dip meter will be found to be one of the most used items of test equipment in the station.

31-1 Voltage and Current

The measurement of *voltage* and *current* in radio circuits is very important in proper maintenance of equipment. Vacuum tubes and transistors of the types used in communications work must be operated within rather narrow limits in regard to filament or collector voltage, and they must be operated within certain maximum limits in regard to the voltage and current on other electrodes.

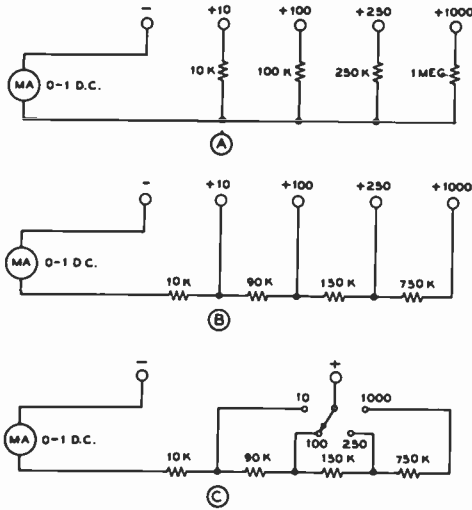

Figure 1

MULTIVOLTMETER CIRCUITS

A shows a circuit whereby individual multiplier resistors are used for each range. B is the more economical "series-multiplier" circuit. The same number of resistors is required, but those for the higher ranges have less resistance, and hence are less expensive when precision wirewound resistors are to be used. C shows a circuit essentially the same as at A, except that a range switch is used. With a 0-500 d-c microammeter substituted for the 0-1 milliammeter shown above, all resistor values would be multiplied by two and the voltmeter would have a "2000-ohms-per volt" sensitivity. Similarly, if a 0-50 d-c microammeter were to be used, all resistance values would be multiplied by twenty, and the voltmeter would have a sensitivity of 20,000 ohms per volt.

Both direct current and voltage are most commonly measured with the aid of an instrument consisting of a coil that is free to rotate in a constant magnetic field (*d'Arsonval* type instrument). If the instrument is to be used for the measurement of current it is called an *ammeter* or *milliammeter*. The current flowing through the circuit is caused to flow through the moving coil of this type of instrument. If the current to be measured is greater than 10 milliamperes or so, it is the usual practice to cause the majority of the current to flow through a bypass resistor called a *shunt*, only a specified portion of the current flowing through the moving coil of the instru-

ment. The calculation of shunts for extending the range of d-c milliammeters and ammeters is discussed in Chapter Two.

A direct current *voltmeter* is merely a d-c milliammeter with a *multiplier* resistor in series with it. If it is desired to use a low-range milliammeter as a voltmeter the value of the multiplier resistor for any voltage range may be determined from the following formula:

$$R = \frac{1000 E}{I}$$

where,

R equals multiplier resistor in ohms,

E equals desired full-scale voltage,

I equals full-scale current of meter in ma.

The sensitivity of a voltmeter is commonly expressed in *ohms per volt*. The higher the ohms per volt of a voltmeter the greater its sensitivity. When the full-scale current drain of a voltmeter is known, its sensitivity rating in ohms per volt may be determined by:

$$\text{Ohms per volt} = \frac{1000}{I}$$

where,

I is the full-scale current drain of the indicating instrument in milliamperes.

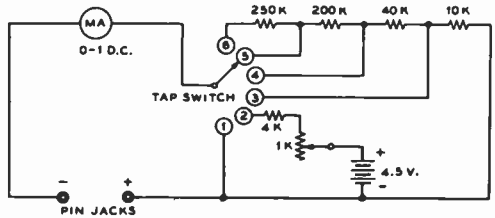

Figure 2

VOLTOHMMETER CIRCUIT

With the switch in position 1, the 0-1 milliammeter would be connected directly to the terminals. In position 2 the meter would read from 0-100,000 ohms, approximately, with a resistance value of 4500 ohms at half scale. (Note: The half-scale resistance value of an ohmmeter using this circuit is equal to the resistance in series with the battery inside the instrument.) The other four taps are voltage ranges with 10, 50, 250, and 500 volts full scale.

Multirange Meters It is common practice to connect a group of multiplier resistors in the circuit with a single indicating instrument to obtain a *multirange voltmeter*, or *multivoltmeter*. There are several ways of wiring such a meter, the most common ones of which are indicated in figure 1. With all these methods of connection, the sensitivity of the meter in ohms per volt is the same on all scales. With a 0-1 milliammeter, as shown, the sensitivity is 1000 ohms per volt.

Voltohmmeters An extremely useful piece of test equipment which should be found in every laboratory or radio station is the *voltohmmeter (v.o.m.)*. It consists of a multirange voltmeter with an additional fixed resistor, a variable resistor, and a battery. A typical example of such an instrument is diagramed in figure 2. Tap 1 is used to permit use of the instrument as a 0-1 d-c milliammeter. Tap 2 permits accurate reading of resistors up to 100,000 ohms; taps 3, 4, 5, and 6 are for making voltage measurements, the full-scale voltages being 10, 50, 250, and 500 volts respectively.

The 1000-ohm potentiometer is used to bring the needle to zero ohms when the terminals are shorted; this adjustment should always be made before a resistance measurement is taken. Higher voltages than 500 can be read if a higher value of multiplier resistor is added to an additional tap on the switch. The proper value for a given full-scale reading can be determined from Ohm's Law.

Resistances higher than 100,000 ohms cannot be measured accurately with the circuit constants shown; however, by increasing the ohmmeter battery to 45 volts and multiplying the 4000-ohm resistor and 1000-ohm potentiometer by 10, the ohms scale also will be multiplied by 10. This would permit accurate measurements up to 1 meg-ohm.

For home-made voltohmmeters, good quality carbon resistors whose actual resistance has been checked may be used as multipliers where less accuracy is required.

Medium- and Low-Range Ohmmeter Most ohmmeters, including the one just described, are not adapted for accurate measurement of low-resistances — in the neighborhood of 100 ohms, for instance.

The ohmmeter diagramed in figure 3 was especially designed for the reasonably accurate reading of resistances down to 1 ohm. Two scales are provided, one going in one direction and the other scale going in the other direction because of the different manner in which the milliammeter is used in each case. The low scale covers from 1 to 100 ohms and the high scale from 100 to 10,000 ohms. The high scale is in reality a medium-range scale. For accurate reading of resistances over 10,000 ohms, an ohmmeter of the type previously described should be used.

The calibration scale will depend on the internal resistance of the particular make of 1.5-ma meter used. The instrument can be calibrated by means of a Wheatstone bridge or a few resistors of known accuracy. The latter can be series-connected and parallel-connected to give sufficient calibration points. A hand-drawn hand-calibrated scale can be cemented over the regular meter scale to give a direct reading in ohms.

Before calibrating the instrument or using it, the test prods should always be

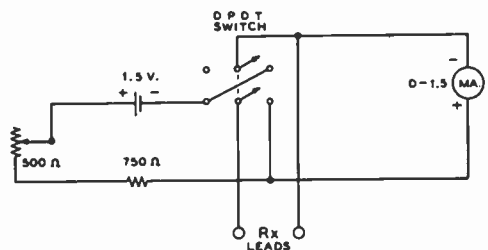

Figure 3

SCHEMATIC OF A LOW-RANGE OHMMETER

A description of the operation of this circuit is given in the text. With the switch in the left position the half-scale reading of the meter will occur with an external resistance of 1000 ohms. With the switch in the right position, half-scale deflection will be obtained with an external resistance equal to the d-c resistance of the milliammeter (20 to 50 ohms depending on the make of instrument).

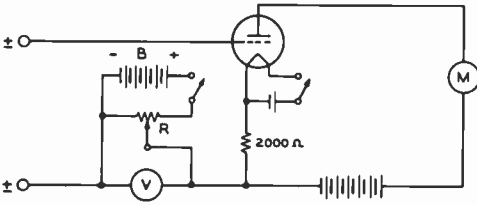

Figure 4

SLIDE-BACK V-T VOLTMETER

By connecting a variable source of voltage in series with the input to a conventional v-t voltmeter, or in series with the simple triode voltmeter shown above, a slide-back a-c voltmeter for peak voltage measurement can be constructed. Resistor *R* should be about 1000 ohms per volt used at battery *B*. This type of v-t voltmeter has the advantage that it can give a reading of the actual peak voltage of the wave being measured, without any current drain from the source of voltage.

touched together and the zero adjuster set accurately.

Measurement of Alternating Current and Voltage

The measurement of alternating current and voltage is complicated by two factors; first,

the frequency range covered in ordinary communication channels is so great that calibration of an instrument becomes extremely difficult; second, there is no single type of instrument which is suitable for all a-c measurements—as the d'Arsonval type of movement is suitable for d-c. The d'Arsonval movement will not operate on alternating current since it indicates the average value of current flow, and the average value of an a-c wave is zero.

As a result of the inability of the reliable d'Arsonval type of movement to record an alternating current, either this current must be rectified and then fed to the movement, or a special type of movement which will operate from the *effective* value of the current can be used.

For the usual measurements of power-frequency alternating current (25-60 Hz), the *iron-vane* instrument is commonly used. For audio frequency alternating current (50-20,000 Hz) a d'Arsonval instrument having an integral copper-oxide, selenium, or

silicon rectifier is usually used. Radio-frequency voltage measurements are usually made with some type of vacuum-tube or solid-state voltmeter, while r-f current measurements are usually made with an instrument containing a thermocouple to convert the radio-frequency current into direct current for the meter movement.

Since an alternating-current wave can have an almost infinite variety of shapes, it can easily be seen that the ratios between the three fundamental quantities of the wave (peak, rms, effective, and average after rectification) can also vary widely. So it becomes necessary to know beforehand just which quality of the wave under measurement our instrument is going to indicate. For the purpose of simplicity we can list the usual types of alternating-current meters along with the characteristic of an alternating-current wave which they will indicate:

Iron-vane, thermocouple—rms.

Rectifier type (copper-oxide selenium, etc.)—average after rectification.

Vacuum-tube or solid-state voltmeter—rms, average, or peak, depending on design and calibration of the meter.

31-2 The Vacuum-Tube Voltmeter

A *vacuum-tube voltmeter* is essentially a detector in which a change in the signal placed on the input will produce a change in the indicating instrument (usually a d'Arsonval meter) placed in the output circuit. A vacuum-tube voltmeter may use a diode, a triode, or a multielement tube (or it may be transistorized) and it may be used either for the measurement of alternating or direct current.

When a vtvm is used in d-c measurement it is used for this purpose primarily because of the very great input resistance of the device. This means that a v.t.v.m. may be used for the measurement of avc, afc, and discriminator output voltages where no loading of the circuit can be tolerated.

A-C V-T Voltmeters There are many different types of a-c vacuum-tube voltmeters, all of which operate as some type of rectifier to give an indication on a d-c instrument. There are two general types: those which give an indication of the rms value of the wave (or approximately this value of a complex wave), and those which give an indication of the peak or crest value of the wave.

Since the adjustment and calibration of a wide-range vacuum-tube voltmeter is rather tedious, in most cases it will be best to purchase a commercially manufactured unit. Several excellent commercial units are on the market at the present time; also kits for home construction of a quite satisfactory v.t.v.m. are available from several manufacturers. These feature a wide range of a-c and d-c voltage scales at high sensitivity, and, in addition, several feature a built-in vacuum-tube ohmmeter which will give indications up to 500 or 1000 megohms.

Peak A-C V-T Voltmeters There are two common types of peak-indicating vacuum-tube voltmeters. The first is the so-called *slide-back* type in which a simple v.t.v.m. is used along with a conventional d-c voltmeter and a source of bucking bias in series with the input. With this type of arrangement (figure 4) leads are connected to the voltage to be measured and the slider resistor R across the bucking voltage is backed down until an indication on the meter (called a false zero) equal to that value given with the prods shorted and the bucking voltage reduced to zero, is obtained. Then the value of the bucking voltage (read on V) is equal to the peak value of the voltage under measurement. The slide-back voltmeter has the disadvantage that it is not instantaneous in its indication—adjustments must be made for every voltage measurement. For this reason the slide-back v.t.v.m. is not commonly used, being supplanted by the diode-rectifier type of peak v.t.v.m. for most applications.

High-Voltage Diode Peak Voltmeter A diode vacuum-tube voltmeter suitable for the measurement of high values of a-c voltage is diagramed in figure

5. With the constants shown, the voltmeter has two ranges—500 and 1500 volts *peak* full scale.

Capacitors C_1 and C_2 should be able to withstand a voltage in excess of the highest peak voltage to be measured. Likewise, R_1 and R_2 should be able to withstand the same amount of voltage. The easiest and least expensive way of obtaining such resistors is to use several low-voltage resistors in series, as shown in figure 5. Other voltage ranges can be obtained by changing the value of these resistors, but for voltages less than several hundred volts a more linear calibration can be obtained by using a receiver-type diode. A calibration curve should be run to eliminate the appreciable error due to the high internal resistance of the diode, preventing the capacitor from charging to the full peak value of the voltage being measured.

A direct-reading diode peak voltmeter of the type shown in figure 5 will load the source of voltage by approximately *one-half* the value of the load resistance in the circuit (R_1 , or R_1 plus R_2 , in this case). Also, the peak voltage reading on the meter will be slightly less than the actual peak voltage being measured. The amount of

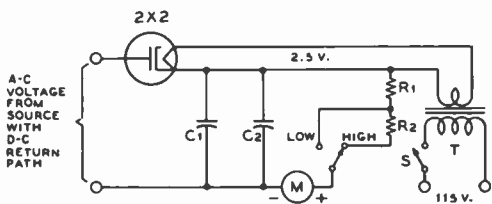

Figure 5

SCHEMATIC OF A HIGH-VOLTAGE PEAK VOLTMETER

This peak voltmeter is convenient for the measurement of peak voltages at fairly high power levels from a source of moderately low impedance.

C_1 —.001- μ fd high-voltage mica

C_2 —1.0- μ fd high-voltage paper

R_1 —500,000 ohms (two 0.25-megohm $\frac{1}{2}$ -watt in series)

R_2 —1.0 megohm (four 0.25-megohm $\frac{1}{2}$ -watt in series)

T—2.5 v., 1.75 amp filament transformer

M—0-1 d-c milliammeter

(Note: C_1 is a bypass around C_2 , the inductive reactance of which may be appreciable at high frequencies.)

lowering of the reading is determined by the ratio of the reactance of the storage capacitance to the load resistance. If a cathode-ray oscilloscope is placed across the terminals of the v.t.v.m. when a voltage is being measured, the actual amount of the lowering in voltage may be determined by inspection of the trace on the cathode-ray tube screen. The peak positive excursion of the wave will be slightly flattened by the action of the v.t.v.m. Usually this flattening will be so small as to be negligible.

An alternative arrangement, shown in figure 6, is quite convenient for the measurement of high a-c voltages such as are encountered in the adjustment and testing of high-power audio amplifiers and modulators. The arrangement consists simply of a 2X2 rectifier tube and a filter capacitor of perhaps 0.25- μ fd capacitance, but with a voltage rating high enough that it is not likely to be punctured as a result of any tests made. Cathode-ray oscilloscope capacitors, and those for electrostatic-deflection TV tubes often have ratings as high as 0.25 μ fd at 7500 to 25,000 volts. The indicating instrument is a conventional multiscale d-c voltmeter of the high-sensitivity type, preferably with a sensitivity of 20,000 or 50,000 ohms per volt. The higher the sen-

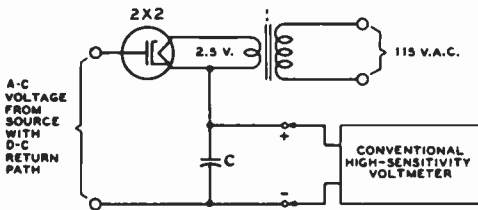

Figure 6

PEAK-VOLTAGE MEASUREMENT CIRCUIT

Through use of the arrangement shown above it is possible to make accurate measurements of peak a-c voltages, such as across the secondary of a modulation transformer, with a conventional d-c multivoltmeter. Capacitor C and transformer T should, of course, be insulated for the highest peak voltage likely to be encountered. A capacitance of 0.25- μ fd at C has been found to be adequate. The higher the sensitivity of the indicating d-c voltmeter, the smaller will be the error between the indication on the meter and the actual peak voltage being measured.

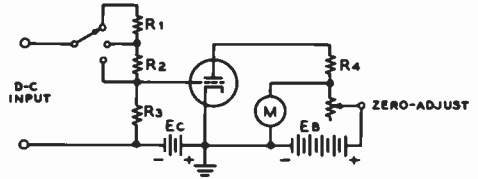

Figure 7

D-C VACUUM-TUBE VOLTMETER

sitivity of the d-c voltmeter used with the rectifier, the smaller will be the amount of flattening of the a-c wave as a result of the rectifier action.

Basic D-C Vacuum-Tube Voltmeter

A simple v.t.v.m. is shown in figure 7. The plate load may be a mechanical device, such as a relay or a meter, or the output voltage may be developed across a resistor and used for various control purposes. The tube is biased by E_c and a fixed value of plate current flows, causing a fixed voltage drop across plate-load resistor R_4 . When a positive d-c voltage is applied to the input terminals it cancels part of the negative grid bias, making the grid more positive with respect to the cathode. This grid-voltage change permits a greater amount of plate current to flow, and develops a greater voltage drop across the plate-load resistor. A negative input voltage would decrease the plate current and decrease the voltage drop across R_4 . The varying voltage drop across R_4 may be employed as a control voltage for relays or other devices. When it is desired to measure various voltages, a *voltage range* switch may precede the vtvm. The voltage to be measured is applied to voltage divider (R_1, R_2, R_3) by means of the *voltage range* switch. Resistor R_4 is used to protect the meter from excessive input voltage to the v.t.v.m. In the plate circuit of the tube a battery and a variable resistor (*zero adjustment*) are used to balance out the meter reading of the normal plate current of the tube. The *zero-adjustment* potentiometer can be so adjusted that the meter (M) reads zero current with no input voltage to the v.t.v.m. When a d-c input voltage is applied to the circuit, current

flows through the meter, and the meter reading is proportional to the applied d-c voltage.

The Bridge-type V.T.V.M. Another important use of a d-c amplifier is to show the exact point of balance between two d-c voltages. This is done by means of a bridge circuit with two d-c amplifiers serving as two legs of the bridge (figure 8). With no input signal, and with matched triodes, no current will be read on meter *M*, since the *IR* drops across *R*₁ and *R*₂ are identical. When a signal is applied to one tube, the *IR* drops in the plate circuits become unbalanced, and meter *M* indicates the unbalance. In the same way, two d-c voltages may be compared if they are applied to the two input circuits. When the voltages are equal, the bridge is balanced and no current flows through the meter. If one voltage changes, the bridge becomes unbalanced and indication of this will be noted by a reading of the meter.

A Modern V.T.V.M. For the purpose of analysis, the operation of a modern v.t.v.m. will be described. The *Heathkit IM-13* is a fit instrument for such a description, since it is able to measure positive or negative d-c potentials, a-c rms values, peak-to-peak values, and resistance. The circuit of this unit is shown in figure 9. A sensitive 0 to 200 d-c microammeter is placed in the cathode circuit of a 12AU7 twin triode. The *zero-adjust* control sets up a balance between the two sections of the triode such that with zero input voltage applied to the first grid, the voltage drop across each portion of the zero-adjust con-

trol is the same. Under this condition of balance the meter will read zero. When a voltage is applied to the first grid, the balance in the cathode circuits is upset and the meter indicates the degree of unbalance. The relationship between the applied voltage on the first grid and the meter current is linear and therefore the meter can be calibrated with a linear scale. Since the tube is limited in the amount of current it can draw, the meter movement is electronically protected.

The maximum test voltage applied to the 12AU7 tube is about 3 volts. Higher applied voltages are reduced by a voltage divider which has a total resistance of about 10 megohms. An additional resistance of 1-megohm is located in the d-c test probe, thereby permitting measurements to be made in high-impedance circuits with minimum disturbance.

The rectifier portion of the vtvm is shown in figure 10. When a-c measurements are desired, a 6AL5 double diode is used as a full-wave rectifier to provide a d-c voltage proportional to the applied a-c voltage. This d-c voltage is applied through the voltage divider string to the 12AU7 tube causing the meter to indicate in the manner previously described. The a-c voltage scales of the meter are calibrated in both rms and peak-to-peak values. In the 1.5, 5, 15, 50, and 150 volt positions of the range switch, the full a-c voltage being measured is applied to the input of the 6AL5 full-wave rectifier. On the 500 and 1500 volt positions of the range switch, a divider network reduces the applied voltage in order to limit the voltage input to the 6AL5 to a safe recommended level.

The *a-c calibrate* control (figure 9) is used to obtain the proper meter deflection for the applied a-c voltage. Vacuum tubes develop a *contact potential* between tube elements. Such contact potential developed in the diode would cause a slight voltage to be present at all times. This voltage is cancelled out by proper application of a bucking voltage. The amount of bucking voltage is controlled by the *a-c balance* control. This eliminates zero shift of the meter when switching from a-c to d-c readings.

For resistance measurements, a 1.5-volt battery is connected through a string of multipliers and the external resistance to be

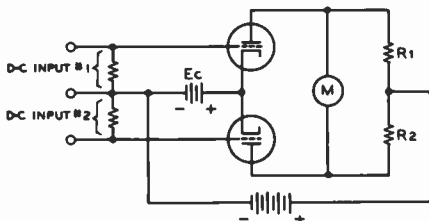

Figure 8
BRIDGE-TYPE VACUUM-TUBE
VOLTMETER

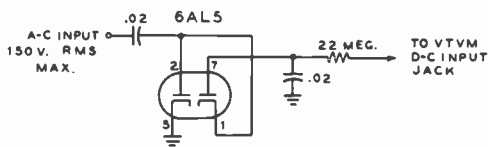

Figure 10

FULL-WAVE RECTIFIER FOR V.T.V.M.

measured, thus forming a voltage divider across the battery, and a resultant portion of the battery voltage is applied to the 12AU7 twin triode. The meter scale is calibrated in resistance (ohms) for this function.

Test Probes Auxiliary test probes may be used with the v.t.v.m. to extend the operating range, or to measure radio frequencies with high accuracy. Shown in figure 11 is a radio-frequency probe which provides linear response to over 100 MHz. A 1N34A is used as a rectifier, and d-c isolation is provided by a .005- μ fd capacitor. The components of the detector are mounted within a shield at the end of a length of coaxial line, which terminates in the d-c input jack of the v.t.v.m. The readings obtained are rms, and should be multiplied by 1.414 to convert to peak readings.

31-3 Solid-State Voltmeters

Solid-state devices are commonly used in electronic test equipment, although the relatively low input impedance of many bipolar transistors has limited their use in measuring circuits. The popular field-effect transistor,

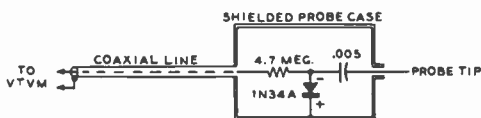

Figure 11

R-F PROBE SUITABLE FOR USE IN 1 kHz-100 MHz RANGE

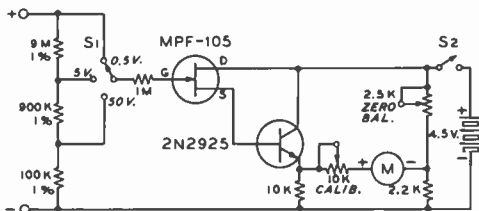

Figure 12

FET SOLID-STATE VOLTMETER

Two low-cost transistors provide highly linear, high-impedance voltmeter. Meter M is 0-50 d-c microammeter.

on the other hand, exhibits a sufficiently high input impedance to make it an acceptable substitute for a vacuum tube in common volttohmmeter circuits.

FET Voltmeter A popular and economical FET d-c voltmeter circuit is shown in figure 12. A Motorola MPF-105 N-channel FET affords an input impedance of about 10 megohms. A voltage divider permits a maximum of 0.5 volt to be applied to the gate of the FET which is connected as a source follower directly coupled to an inexpensive 2N2925 transistor. With no signal, the drop across the 10K emitter resistor is about 1.6 volts, rising to about 2.1 volts when a .05-volt calibrating signal is applied to the arm of the voltage-divider switch. The 2N2925 is one arm of a bridge circuit whose state of balance is indicated on meter M. Bridge balance is set by the zero balance potentiometer, and full-scale calibration is adjusted by the 10K potentiometer in series with the meter.

The linearity of this simple instrument is largely controlled by the value of the 10K emitter-to-minus resistor. Calibration should be checked at full scale with .05-volt input, and at one-tenth full scale. If the meter reading is low at the lower reading, the 10K resistor should be increased in value.

A MOSFET A-C Voltmeter The insulated gate field-effect (MOS) N-channel transistor is suitable for use in an inexpensive and accurate a-c voltmeter, such as the circuit shown in figure 13. The instrument

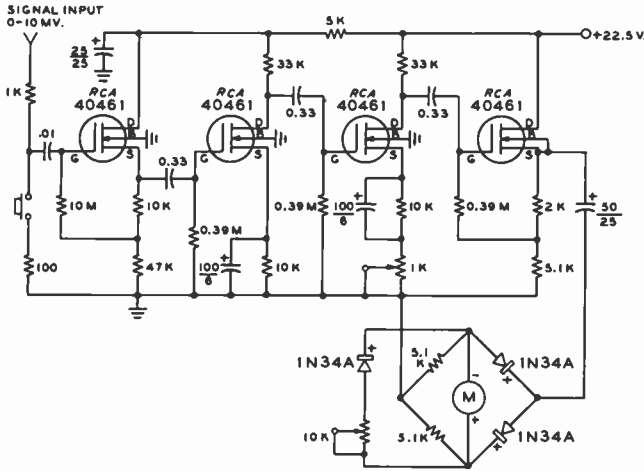

Figure 13

MOSFET A-C VOLTMETER

Instrument response is 20 Hz-20 kHz. Meter M is 0-1 d-c milliammeter. Transistor leads should be shorted together until units are in circuit. Jumper leads should be across sockets until wiring is completed and transistors in place.

has an input impedance of over 1 megohm, a full-scale sensitivity of 10 millivolts and a flat frequency response over the range of 20 to 20,000 Hz.

Four stages of amplification are used to drive a rectifier-bridge circuit utilizing an inexpensive 1-milliamper d-c meter. The first MOSFET stage is operated as a source follower, presenting a very low input capacitance to the input-signal voltage divider. Two common-source amplifier stages provide a gain of about 200, with the ultimate gain controlled by varying the amount of negative feedback voltage by means of a 1K potentiometer placed in the source circuit of the third stage. With a 10-millivolt signal at the input of the first stage, the maximum output voltage at the drain of the third stage should be about 2.8 volts, rms.

The fourth stage is a source follower to approximate the low input impedance of the meter rectifier circuit. A series diode and potentiometer arrangement are used to compensate for the nonlinear rectification characteristic of the rectifier diodes at the low end of the meter scale. The 10K series resistor should be adjusted for best meter scale linearity.

A 100-to-1 voltage divider is placed ahead of the input coupling capacitor of the first stage to protect the gate of the 40461 MOSFET from overload. A *push-to-read* (normally closed) switch removes this special attenuator network from the circuit. A

conventional voltage divider circuit to extend the range of the meter may be placed ahead of the protection device.

Total current consumption for the instrument is less than 3 milliamperes from a 22.5-volt battery.

31-4 Power Measurements

Audio and R-F Power Audio-frequency or radio-frequency power in a resistive circuit is most commonly and most easily determined by the indirect method, i.e., through the use of one of the following formulas:

$$P = EI, \quad P = E^2/R, \quad P = I^2R$$

These three formulas mean that if any two of the three factors determining power are known (resistance, current, voltage) the power being dissipated may be determined. In an ordinary 117-volt a-c line circuit the above formulas are not strictly true since the power factor of the load must be multiplied into the result—or a direct method of determining power such as a wattmeter may be used. But in a resistive a-f circuit and in a resonant r-f circuit the power factor of the load is taken as being unity.

For accurate measurement of a-f and r-f power, a *thermogalvanometer* or *thermocouple* ammeter in series with a noninductive resistor of known resistance can be used.

The meter should have good accuracy, and the exact value of resistance should be known with accuracy. Suitable dummy-load resistors are available in various resistances in both 100- and 250-watt ratings. These are virtually noninductive, and may be considered as a pure resistance up to 30 MHz.

Sine-wave power measurements (r-f or single-frequency audio) may also be made through the use of a vtvm and a resistor of known value. In fact a vtvm of the type shown in figure 9 is particularly suited to this work. The formula, $P = E^2/R$ is used in this case. However, it must be remembered that a vtvm of the type shown in figure 9 indicates the *peak* value of the a-c wave. This reading must be converted to the rms or *heating* value of the wave by multiplying it by 0.707 before substituting the voltage value in the formula. The same result can be obtained by using the formula $P = E^2/2R$. (Note: Some vtvm's are *peak reading* but are calibrated rms on the meter scale).

Power may also be measured through the use of a *calorimeter*, by actually measuring the amount of heat being dissipated. Through the use of a water-cooled dummy-load resistor this method of power output determination is being used by some of the most modern broadcast stations. But the method is too cumbersome for ordinary power determinations.

Power may also be determined *photometrically* through the use of a voltmeter, ammeter, incandescent lamp used as a load resistor, and a photographic exposure meter. With this method the exposure meter is used to determine the relative visual output of the lamp running as a dummy-load resistor and of the lamp running from the 117-volt a-c line. A rheostat in series with the lead from the a-c line to the lamp is used to vary its light intensity to the same value (as indicated by the exposure meter) as achieved as a dummy load. The a-c voltmeter in parallel with the lamp and ammeter in series with it is then used to determine lamp power input by: $P = EI$. This method of power determination is satisfactory for audio and low-frequency r.f. but is not satisfactory for vhf work because

of variations in lamp efficiency due to uneven heating of the filament.

Finally, r-f power may be measured by means of a *directional coupler*, as discussed later in this chapter.

Dummy Loads Lamp bulbs make poor dummy loads for r-f work, in general, as they have considerable reactance above 2 MHz, and the resistance of the lamp varies with the amount of current passing through it.

A suitable r-f load for power up to a few watts may be made by paralleling 2-watt composition resistors of suitable value to make a 50-ohm resistor of adequate dissipation.

A 2-kW dummy load having an SWR of less than 1.05 to 1 at 30 MHz is shown in figures 14, 15, and 16. The load consists of twelve 600-ohm, 120-watt *Globar type CX* noninductive resistors connected in parallel. A frequency-compensation circuit is used



Figure 14

2-KILOWATT DUMMY LOAD FOR 3-30 MHz

Load is built in case measuring 22" deep, 11" wide and 5" high. Meter is calibrated in watts against microampere scale as follows: (1), 22.3 μ a. (5), 50 μ a. (10), 70.5 μ a. (15), 86.5 μ a. (20), 100 μ a. Scale may be marked off as shown in photograph. Calibration technique is discussed in text. Alternatively, a standing-wave bridge (calibrated in watts) such as "Micromatch" may be used to determine power input to load.

Vents in top of case, and 1/4-inch holes in chassis permit circulation of air about resistors. Unit should be fan-cooled for continuous dissipation.

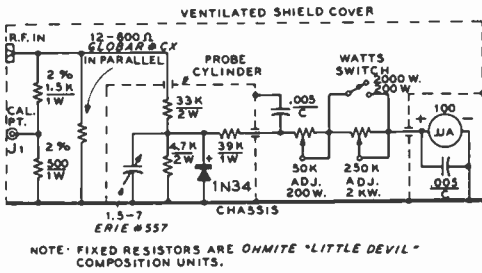

Figure 15

SCHEMATIC, KILOWATT DUMMY LOAD

to balance out the slight capacitive reactance of the resistors. The compensation circuit is mounted in an aluminum tube 1" in diameter and 2 5/8" long. The tube is plugged at the ends by metal discs, and is mounted to the front panel of the box.

The resistors are mounted on aluminum T-bar stock and are grounded to the case at the rear of the assembly. Connection to the coaxial receptacle is made via copper strap.

The power meter is calibrated using a v.t.v.m. and r-f probe. Power is applied to the load at 3.5 MHz and the level is adjusted to provide 17.6 volts at "Calibration point." With the *Watts Switch* in the 200-watt position, the potentiometer is adjusted to provide a reading of 100 watts on the meter. In the 2000-watt position, the other poten-

tiometer is adjusted for a meter reading of 200 watts. The excitation frequency is now changed to 29.7 MHz and the 17.6-volt level re-established. Adjust the frequency-compensating capacitor until meter again reads 100 watts. Recheck at 3.5 MHz and repeat until meter reads 100 watts at each frequency when 17.6-volt level is maintained.

31-5 Measurement of Circuit Constants

The measurement of the resistance, capacitance, inductance, and Q (figure of merit) of the components used in communications work can be divided into three general methods: the impedance method, the substitution or resonance method, and the bridge method.

The Impedance Method The *impedance method* of measuring inductance and capacitance can be likened to the ohmmeter method for measuring resistance. An a-c voltmeter, or milliammeter in series with a resistor, is connected in series with the inductance or capacitance to be measured and the a-c line. The reading of the meter will be inversely proportional to the impedance of the component being measured. After the meter has been calibrated it will be possible to obtain the ap-

Figure 16

DUMMY-LOAD ASSEMBLY

Twelve Globar resistors (surplus) are mounted to aluminum "Tee" stock, six to a side, in fuse clips. Right end is supported by ceramic pillars from front panel. Probe, meter, and potentiometers are at right.

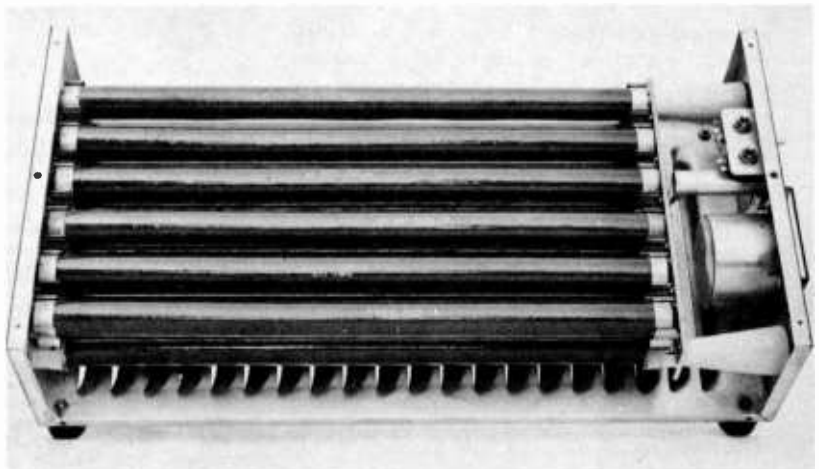

proximate value of the impedance directly from the scale of the meter. If the component is a capacitor, the value of impedance may be taken as its reactance at the measurement frequency and the capacitance determined accordingly. But the d-c resistance of an inductor must also be taken into consideration in determining its inductance. After the d-c resistance and the impedance have been determined, the reactance may be determined from the formula: $X_L = \sqrt{Z^2 - R^2}$. Then the inductance may be determined from: L equals $X_L/2\pi f$.

The Substitution Method The *substitution method* is a satisfactory system for

obtaining the inductance or capacitance of high-frequency components. A large variable capacitor with a good dial having an accurate calibration curve is a necessity for making determinations by this method. If an unknown inductor is to be measured, it is connected in parallel with the standard capacitor and the combination tuned accurately to some known frequency. This tuning may be accomplished either by using the tuned circuit as a wavemeter and coupling it to the tuned circuit of a reference oscillator, or by using the tuned circuit in the controlling position of a two terminal oscillator such as a dynatron or transistor. The capacitance required to tune this first frequency is then noted as C_1 . The circuit or the oscillator is then tuned to the *second harmonic* of this first frequency and the amount of capacitance again noted, this time as C_2 . Then the distributed capacitance across the coil (including all stray capacitances) is equal to: $C_0 = (C_1 - 4C_2)/3$.

This value of distributed capacitance is then substituted in the following formula along with the value of the standard capacitance for either of the two frequencies of measurement:

$$L = \frac{1}{4\pi^2 f_1^2 (C_1 + C_0)}$$

The determination of an unknown capacitance is somewhat less complicated than the

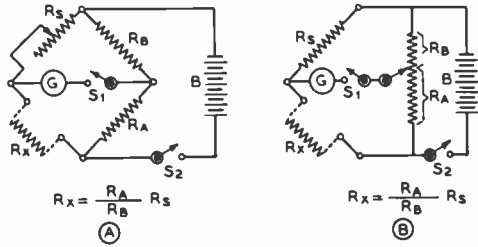

Figure 17

TWO WHEATSTONE BRIDGE CIRCUITS

These circuits are used for the measurement of d-c resistance. In A the "ratio arms" R_A and R_B are fixed and balancing of the bridge is accomplished by variation of the standard R_x . The standard in this case usually consists of a decade box giving resistance in 1-ohm steps from 0 to 1110 or to 11,110 ohms. In B a fixed standard is used for each range and the ratio arm is varied to obtain balance, A calibrated slide wire or potentiometer calibrated by resistance in terms of degrees is usually employed as R_A and R_B . It will be noticed that the formula for determining the unknown resistance from the known is the same in either case.

above. A tuned circuit including a coil, the unknown capacitor and the standard capacitor, all in parallel, is resonated to some convenient frequency. The capacitance of the standard capacitor is noted. Then the unknown capacitor is removed and the circuit re-resonated by means of the standard capacitor. The difference between the two readings of the standard capacitor is then equal to the capacitance of the unknown capacitor.

31-6 Measurements with a Bridge

The Wheatstone Bridge Experience has shown that one of the most satisfactory methods for measuring circuit constants (resistance, capacitance, and inductance) at audio frequencies is by means of the a-c bridge. The *Wheatstone (d-c) bridge* is also one of the most accurate methods for the measurement of d-c resistance. With a simple bridge of the type shown in figure 17A it is entirely practical to obtain d-c resistance determinations ac-

curate to four significant figures. With an a-c bridge operating within its normal rating as to frequency and range of measurement it is possible to obtain results accurate to three significant figures.

Both the a-c and the d-c bridges consist of a source of energy, a standard or reference of measurement, a means of balancing this standard against the unknown, and a means of indicating when this balance has been reached. The source of energy in the d-c bridge is a battery; the indicator is a sensitive galvanometer. In the a-c bridge the source of energy is an audio oscillator (usually in the vicinity of 1000 Hz), and the indicator is usually a pair of headphones. The standard for the d-c bridge is a resistance, usually in the form of a decade box. Standards for the a-c bridge can be resistance, capacitance, and inductance in varying forms.

Figure 17 shows two general types of the Wheatstone or d-c bridge. In A the so-called "ratio arms" (R_A and R_B) are fixed (usually in a ratio of 1-to-1, 1-to-10, 1-to-100, or 1-to-1000) and the standard resistor (R_S) is varied until the bridge is in balance. In commercially manufactured bridges there are usually two or more buttons on the galvanometer for progressively increasing its sensitivity as balance is approached. Figure 17B is the *slide-wire* type of bridge in which fixed standards are used and the ratio arm is continuously variable. The slide wire may actually consist of a moving contact along a length of wire of uniform cross section in which case the ratio of R_A to R_B may be read off directly in centimeters or inches, or in degrees of rotation if the slide wire is bent around a circular former. Alternatively, the slide wire may consist of a linear-wound potentiometer with its dial calibrated in degrees or in resistance from each end.

Figure 18A shows a simple type of a-c bridge for the measurement of capacitance and inductance. It can also, if desired, be used for the measurement of resistance. It is necessary with this type of bridge to use a standard which presents the same type of impedance as the unknown being measured: resistance standard for a resistance measurement, capacitance standard for capacitance,

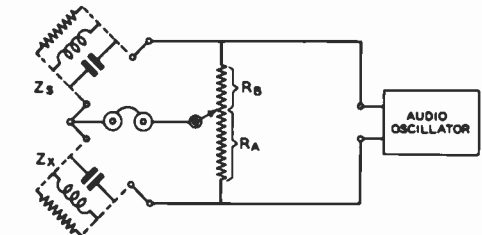

$$Z_x = \frac{R_A}{R_B} Z_s \quad X_x = \frac{R_A}{R_B} X_s \quad R_x = \frac{R_A}{R_B} R_s$$

Z_x = IMPEDANCE BEING MEASURED, Z_s = RESISTANCE COMPONENT OF Z_x
 Z_s = IMPEDANCE OF STANDARD, X_x = REACTANCE COMPONENT OF Z_x
 R_x = RESISTANCE COMPONENT OF Z_x , X_s = REACTANCE COMPONENT OF Z_s

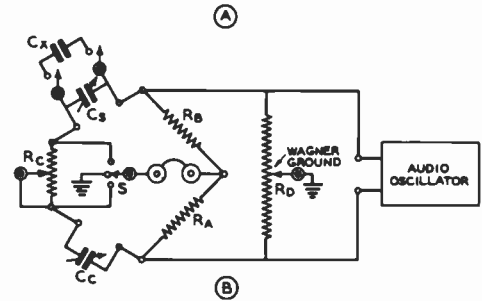

Figure 18
TWO A-C BRIDGE CIRCUITS

The operation of these bridges is essentially the same as those of figure 17 except that a-c is fed into the bridge instead of d-c and a pair of phones is used as the indicator instead of the galvanometer. The bridge shown at A can be used for the measurement of resistance, but it is usually used for the measurement of the impedance and reactance of coils and capacitors at frequencies from 200 to 1000 Hz. The bridge shown at B is used for the measurement of small values of capacitance by the substitution method. Full description of the operation of both bridges is given in the accompanying text.

and inductance standard for inductance determination.

The Wagner Ground For measurement of capacitances from a few picofarads to about 0.001 μ fd, a *Wagner-grounded substitution capacitance bridge* of the type shown in figure 18B will be found satisfactory. The ratio arms R_A and R_B should be of the same value within 1 percent; any value between 2500 and 10,000 ohms for both will be satisfactory. The two resistors R_C and R_D should be 1000-ohm wirewound potentiometers. C_B should be a straight-line capacitance ca-

capacitor with an accurate vernier dial; 500 to 1000 pf will be satisfactory. C_C can be a two- or three-gang broadcast capacitor from 700 to 1000 pf maximum capacitance.

The procedure for making a measurement is as follows: The unknown capacitor C_X is placed in parallel with the standard capacitor C_S . The *Wagner ground* (R_D) is varied back and forth a small amount from the center of its range until no signal is heard in the phones with the switch (S) in the center position. Then the switch (S) is placed in either of the two outside positions, C_C is adjusted to a capacitance somewhat greater than the assumed value of the unknown C_X , and the bridge is brought into balance by variation of the standard capacitor (C_N). It may be necessary to cut some resistance in at R_C and to switch to the other outside position of S before an exact balance can be obtained. The setting of C_S is then noted, C_X is removed from the circuit (but the leads which went to it are not changed in any way which would alter their mutual capacitance), and C_S is readjusted until balance is again obtained. The difference in the two settings of C_N is equal to the capacitance of the unknown capacitor C_X .

31-7 R-F Bridges

The basic bridge circuits are applicable to measurements at frequencies well up into the uhf band. While most of the null circuits used from d.c. to about 100 MHz are adaptations of the fundamental Wheatstone Bridge circuit, many other types of networks that can be adjusted to give zero transmission are employed at higher frequencies.

At very-high frequencies, where impedances can no longer be treated as lumped elements, null circuits based upon coaxial line techniques are used. The upper frequency limit of conventional bridge circuits using lumped parameters is determined by the magnitude of the residual impedance of the elements and the leads. The corrections for these usually become unmanageable at frequencies higher than 100 MHz or so.

The "General Radio" Bridge An r-f bridge suitable for use up to about 60 MHz is shown in figure 19. The bridge can measure resistances up to 1000 ohms and reactances over the range of plus or minus 5000 ohms at 1 MHz. The reactance range varies inversely as the frequency, and at other frequencies the reactance reading must be divided by the frequency in MHz. Measurements are made by a series-substitution method in which the bridge is first balanced by means of capacitors C_P and C_A with a short-circuit across the unknown terminals. The short is then removed, the unknown impedance connected in its place, and the bridge rebalanced. The unknown resistance and reactance values are then read from the difference between the initial and final balances.

A vhf variation of the r-f bridge provides direct measurements up to 500 MHz by sampling the electric and magnetic fields in a transmission line. Two attenuators are controlled simultaneously; one receives energy proportional to the electric field in the line, and the other receives energy proportional to the magnetic field. The magnitude

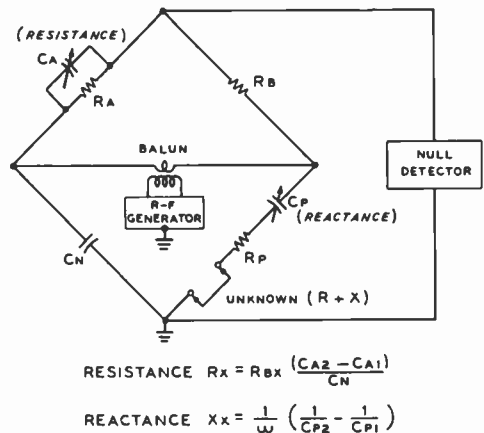

Figure 19

THE "GENERAL RADIO" R-F BRIDGE

This bridge is suitable for r-f measurements up to 60 MHz or so. Calibrated reactance (C_P) and resistance (C_A) dials allow direct measurements at 1 MHz. At other frequencies reactance reading must be divided by the frequency in MHz. Wide-band balun input transformer allows bridge to be driven from signal generator via a coaxial line.

of the unknown impedance is determined by adjusting this combination for equal output from each attenuator. The two equal signals may also be applied to opposite ends of another transmission line, and phase angle can be determined from their point of cancellation.

Above 500 MHz, impedance measurements are normally determined by inserting a detector probe in a slotted section of transmission line, as discussed in the next section of this chapter.

31-8 Antenna and Transmission-Line Instrumentation

The degree of adjustment of any amateur antenna can be judged by a study of the standing-wave ratio on the transmission line feeding the antenna. Various types of instruments have been designed to measure the ratio of forward to reflected power by sampling the *r-f* incident and reflected waves on the transmission line, or to measure the actual radiation resistance and reactance of the antenna in question. The most important of these instruments are the *slotted line*, the *directional coupler*, and the *r-f impedance bridge*.

The Slotted Line The relationship between the incident and the reflected power and standing wave present on a transmission line is expressed by:

$$K = \frac{1 + R}{1 - R}$$

where,

K = Standing-wave ratio,

R = Reflection coefficient, or ratio of relative amplitude of reflected signal to incident signal.

When measurements of a high degree of accuracy are required, it is necessary to insert an instrument into a section of line in order to ascertain the conditions existing within the shielded line. For most vhf measurements, wherein a wavelength is of manageable proportions, a *slotted line* is the

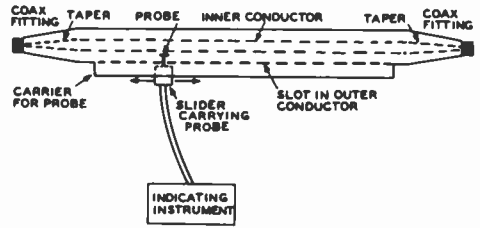

Figure 20

THE UHF SLOTTED LINE

The conductor ratios in the slotted line, including the tapered end sections should be such that the characteristic impedance of the equipment is the same as that of the transmission line with which the equipment is to be used. The indicating instrument may be operated by the d-c output of the rectifier coupled to the probe, or it may be operated by the a-c components of the rectified signal if the signal generator or transmitter is amplitude-modulated at a constant percentage.

instrument frequently used. Such an instrument, shown in figure 20, is an item of test equipment which could be constructed in a home workshop which includes a lathe and other metal-working tools. Commercially built slotted lines are very expensive since they are constructed with a high degree of accuracy for precise laboratory work. The slotted line consists essentially of a section of air-dielectric line having the same characteristic impedance as the transmission line into which it is inserted. Tapered fittings for the transmission line connectors at each end of the slotted line usually are required due to differences in the diameters of the slotted line and the line into which it is inserted. A narrow slot from 1/8-inch to 1/4-inch in width is cut into the outer conductor of the line. A probe then is inserted into the slot so that it is coupled to the field inside the line. Some sort of accurately machined track or lead screw must be provided to ensure that the probe maintains a constant spacing from the inner conductor as it is moved from one end of the slotted line to the other. The probe usually includes some type of rectifying element whose output is fed to an indicating instrument alongside the slotted line.

The unfortunate part of the slotted-line system of measurement is that the line must

be somewhat over one-half wavelength long at the test frequency, and for best results should be a full wavelength long. This requirement is easily met at frequencies of 420 MHz and above where a full wavelength is 28 inches or less. But for the lower frequencies such an instrument is mechanically impractical.

The Directional Coupler The r-f voltage on a transmission line may be considered to have two components. The *forward component* (incident component) and the *reverse component* (reflected component). The reverse component is brought about by operation of the line when terminated in a load that is unequal to the characteristic impedance of the line.

A *directional coupler* is an instrument that can sense either the forward or reflected components in a transmission line by taking advantage of the fact that the reflected components of voltage and current are 180 degrees out of phase while the forward components of voltage and current are in phase.

The directional coupler is inserted in the transmission line at an appropriate location. For a coaxial line, the instrument consists of a short section of line containing a small loop coplanar with the inner conductor (figure 21). The loop is connected through a resistor to the outer conductor, and this resistor is capacitively coupled to the inner conductor of the line. The voltage appearing across the series arrangement of loop and resistor is measured when the voltage across the resistor and the voltage induced in the loop are aiding and again when they are in opposition to each other. By rotating the loop through 180 degrees, the readings may be used to determine the amount of mismatch and the power carried by the line. Operation is substantially independent of load impedance and meter impedance at any frequency within the useful range of the instrument.

When the directional coupler is used to measure the SWR or the reflection coefficient on the line, the value obtained for these quantities depends only on the *ratio* of the two measured voltages. Power measurements are more stringent, since the absolute value

of transmission line voltage must be determined and construction of a simple, compact r-f voltmeter that presents a linear reading over a wide frequency range and at various power levels is not simple.

In order to sample forward and reverse power, it is necessary to reverse the orientation of the directional coupler in the line,

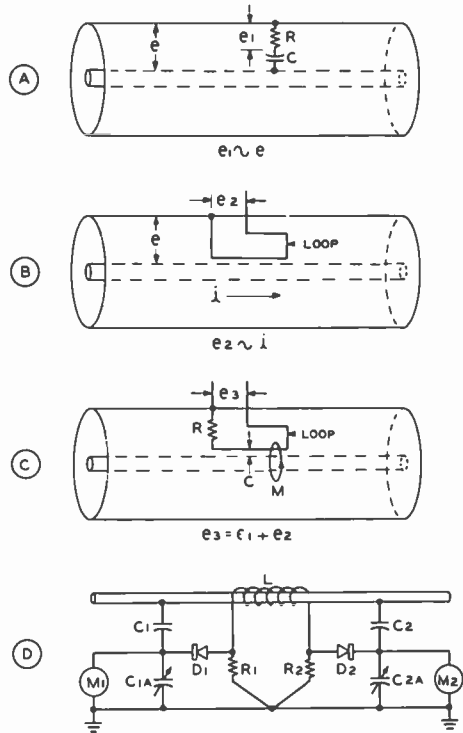

Figure 21

THE DIRECTIONAL COUPLER

The directional coupler (reflectometer) is a coaxial-line section containing an r-f voltmeter which reads the incident or reflected component of voltage, depending on the position of the pickup device in the line.

- A—Voltage relationships for a series resistance-capacitance combination placed between the conductors of a coaxial line; e_1 is proportional to e .
- B—Loop coupled to inner conductor will give voltage (e_2) proportional to current flowing in line (i).
- C—Representation of reflectometer. Capacitance is provided by proximity of loop to inner conductor.
- D—Double reflectometer provides simultaneous measurement of incident and reflected voltages. Ferrite core is placed around center conductor, with secondary winding acting as loop M.

or to employ two couplers built in one unit but oriented oppositely. It is necessary, moreover, to have both couplers identical in *coupling factor* and *directivity*.

The fraction of forward power that is sampled by the coupler is termed the *coupling factor*, and the *directivity* is the ability of the coupler to discriminate between opposite directions of current flow. If, for example one percent of the power is coupled out, the coupling factor is 20 decibels. If the coupler is now reversed to sample the power in the reverse direction, it may couple out, say 0.001 percent of the forward power even though there may be actually no reflected power. It is thus coupling out an amount of power 50 decibels below the power in the line. The discrimination between forward and reverse power is the difference between the coupled values, or 30 decibels. A *directivity* of 30 db is common for better types of reflectometers and SWR measurements derived from the measured reflection coefficient are sufficiently accurate for adjustment of simple beam antennas. It should be noted, however, that it is difficult to make measurements with any degree of accuracy at low SWR values with inexpensive directional couplers, because the directivity power ratio at SWR values below about 1.5/1 or so falls within the error limits of directivity capability of all but the best and most expensive reflectometers.

The SWR Bridge The SWR bridge is a useful device for determining the standing-wave ratio on, and the power transmitted along, a transmission line. When the SWR on a given line is unity, the line is terminated in a pure resistance equal to the characteristic impedance of the line. If the line and terminating load are made part of an r-f bridge circuit, the bridge will be in a balanced condition when the SWR is unity (figure 22). A sensitive r-f voltmeter connected across the bridge will indicate balance and the magnitude of bridge unbalance, and may be calibrated in terms of SWR, power, or both. It may be seen in figure 22A that the meter reading is proportional to bridge unbalance, and is thus proportional to the reflected power and is not influenced by the forward power in the circuit. The meter will read zero if,

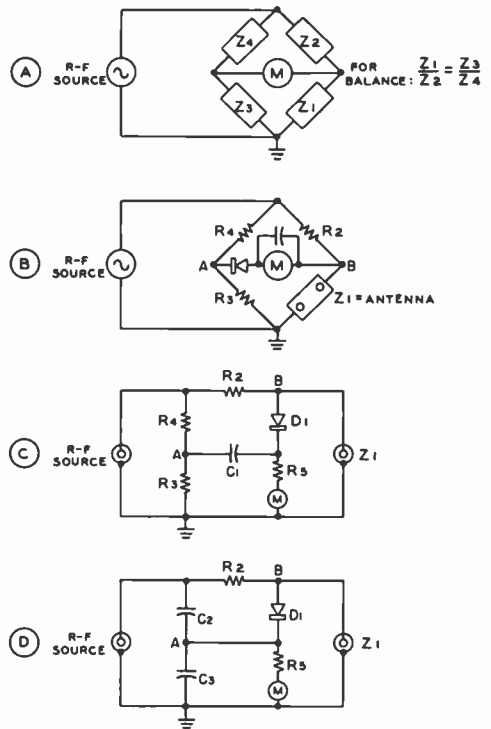

Figure 22

THE BRIDGE DIRECTIONAL COUPLER

A—When r-f bridge is balanced any change in load (Z_1) will result in bridge unbalance and cause a reading on meter M. Reading is due to reflected voltage. SWR may be derived from:

$$SWR = \frac{E_o - E_r}{E_o + E_r}$$

where,
 E_o , equals incident voltage,
 E_r , equals reflected voltage.

B—Equivalent bridge circuit. Bridge must be individually calibrated since performance differs from formula due to nonlinearity of voltmeter, circuit loading, and line discontinuity introduced by presence of bridge.

C, D—Practical bridge circuits having one side of meter grounded to line.

and only if, the transmission line is properly terminated in Z_1 so that $Z_1 = Z_n$ of the line, so as to have unity standing-wave ratio.

Various forms of the SWR resistance bridge exist as shown in the illustration, but all of them are based on the principle of measurement of bridge balance by means of a null-indicating meter. Circuit B consists

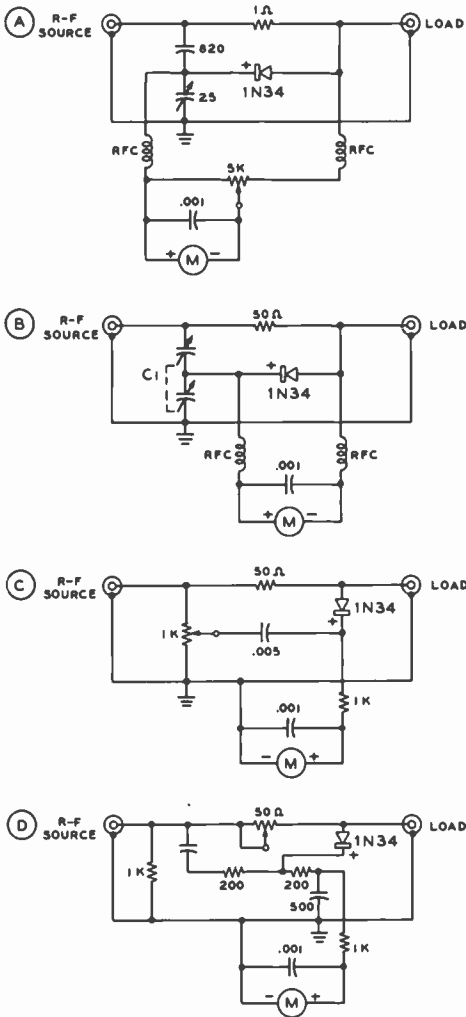

Figure 23

SWR BRIDGES

- A—Micromatch bridge.
 - B—Capacitance ratio bridge.
 - C—Antennascope.
 - D—Antennascope with calibrating resistor in active leg of bridge.
- Note: Meter M may be 0-500 d-c microammeter.

potential. Circuit D is similar, except that one of the voltage dividers of the bridge is capacitive instead of resistive.

SWR Bridge Designs Various forms of the SWR bridge are shown in figure 23. Circuit A is the *Micromatch* capacitance bridge. In order to pass appreciable power through the bridge, the series resistor is reduced to one ohm, thus requiring the capacitance divided to maintain about the same ratio as set in the resistive arm. For a 50-ohm transmission line, the transformation ratio is 50/1, and the 25-pf variable capacitor must be set at a value corresponding to about fifty times the reactance of the 820-pf capacitor. The power-handling capability of the bridge is limited by the dissipation capability of the 1-ohm resistor.

Circuit B incorporates a differential capacitor to obtain an adjustable bridge ratio. The capacitor may be calibrated in terms of the unknown load and may be used to indicate resistive loads in the range of 10 to 500 ohms. The bridge has an advantage over the circuits of illustrations A and C in that it may be used in the manner of a simple impedance bridge to determine the radiation resistance of a *resonant* antenna. The bridge is placed at the antenna terminals, and the frequency of the driving source and the setting of the differential capacitor are varied to produce a null indication on the meter. The null occurs at the resonant frequency of the antenna, and the radiation resistance at that frequency may be read from the instrument.

A less-expensive variation of the variable r-f bridge is shown in illustrations C and D and is called the *Antennascope*. The Antennascope is a variable bridge making use of a (relatively) noninductive potentiometer in one leg. These simple instruments are useful in antenna adjustment as they indicate the resonant frequency of the antenna and the approximate radiation resistance of the driven element at this frequency. At other than the resonant frequency, the antenna exhibits a reactive component and the null of the instrument will not be complete. Even so, at the low values of impedance encountered in most amateur beam antennas, the readings obtained at frequencies off resonance approximate the resistive compo-

of two resistive voltage dividers across the r-f source, with an r-f voltmeter reading the difference of potential across the points A and B. Circuit C is identical, but redrawn so as to show a practical layout for measurement in a coaxial system with one side of the generator and the r-f voltmeter at ground

ment of the radiation resistance of the antenna.

Construction information for a practical Antennascope and other SWR instruments will be described in the following section of this Handbook.

31-9 Practical SWR Instruments

Simple forms of the directional coupler and the SWR bridge are suited to home construction and will work well over the range of 1.8 to 148 MHz. No special tools are needed for construction and calibration may be accomplished with the aid of a handful of 1-watt composition resistors of known d-value resistance.

The Antennascope The *Antennascope* is a modified SWR bridge in which one leg of the bridge is composed of a noninductive variable resistor (figure 23D). This resistor is calibrated in ohms, and when its setting is equal to the radiation resistance of a resonant antenna under test, the bridge is in a balanced state. If a sensitive voltmeter is connected across the bridge, it will indicate a voltage null at bridge balance. The radiation resistance of the antenna may then be read directly from the calibrated dial of the instrument.

When the test antenna is nonresonant, the null indication on the Antennascope will be incomplete. The frequency of the exciting signal must then be altered to the resonant frequency of the antenna to obtain accurate readings of radiation resistance. The resonant frequency of the antenna, of course, is also determined by this exercise.

The circuit of the Antennascope is shown in figure 25. A 100-ohm noninductive potentiometer (R_1) serves as the variable leg of the bridge. The other legs are composed of the 200-ohm composition resistors and the radiation resistance of the antenna. If the radiation resistance of the antenna or external load under test is 50 ohms, and the potentiometer is set at midscale, the bridge is balanced and the diode voltmeter will read zero. If the radiation resistance of the antenna is any other value between about 10 and 100 ohms, the bridge will be balanced to this

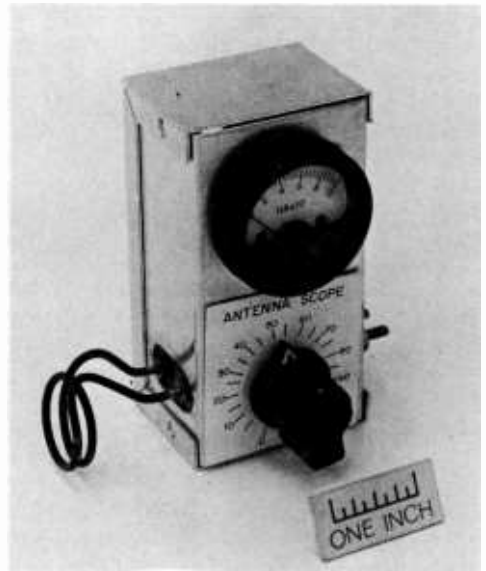

Figure 24

THE ANTENNASCOPE

The antennascope may be used to measure the resonant radiation resistance of antennas at frequencies up to 150 MHz. Grid-dip oscillator is coupled to input loop of antennascope and antenna under test is connected to output terminals with short, heavy leads.

new value by varying the setting on the potentiometer, which is calibrated in ohms.

Building the Antennascope—The Antennascope is constructed within an aluminum box chassis measuring about 4" × 2" × 1½", and placement of the major components may be seen in the photographs. A 1¼-inch diameter hole is drilled in the lower portion of the panel and the variable poten-

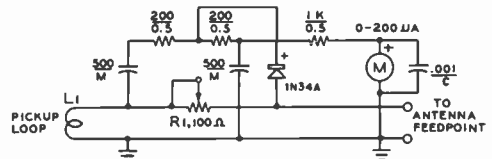

Figure 25

SCHEMATIC, ANTENNASCOPE

R_1 —100-ohm composition potentiometer. Ohmite AB or Allen-Bradley type J linear taper
 L_1 —2 turns brass wire to fit gdo coil. See photos
 M —0-100 μ a d-c meter

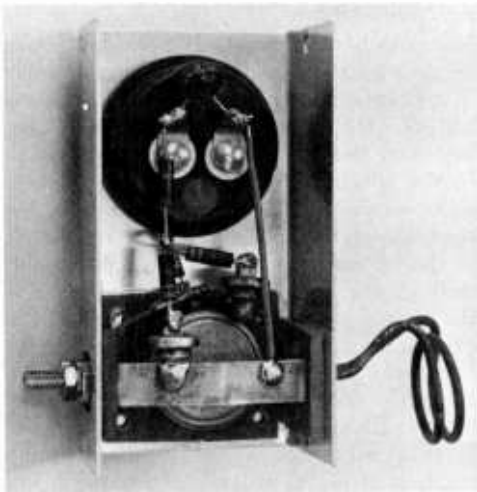

Figure 26

INTERIOR OF ANTENNA SCOPE

Strap connection is made between common input and output terminals. Grid-dip oscillator coupling loop is at right.

tiometer is mounted in this hole on a thin piece of insulating material such as micarta or bakelite. The terminals of the potentiometer and the case are at r-f potential, so it is essential for proper bridge operation to have a minimum of capacitance between the potentiometer and ground.

The two 200-ohm, $\frac{1}{2}$ -watt resistors should be matched on an ohmmeter, and a number of the 500-pf capacitors should be checked on a bridge to find two units of equal capacitance. The exact value of resistance and capacitance in either case is not critical, it is only necessary that the companion units be equal in value. Care should be taken when soldering the small resistors in the circuit to see that they do not become overheated, causing the resistance value to permanently change. In like manner, the germanium diode should be soldered in the circuit using a pair of long-nose pliers as a heat sink to remove the soldering heat from the unit as rapidly as possible.

As shown in the photographs, copper strap cut from flashing stock is used for wiring the important r-f leads. The output leads terminate in an insulated terminal strip on one side of the box and the input coupling loop is made of a section of brass rod,

which is tapped at each end for 6-32 machine nuts. The loop is bent and positioned so as to slip over the coil of a grid-dip oscillator used as the driving source.

Testing the Antennascope—When the instrument is completed, a grid-dip oscillator may be coupled to the input link. The oscillator should be set somewhere in the 10-MHz to 20-MHz range and coupling is adjusted to obtain a half-scale reading on the meter of the Antennascope. Various values of precalibrated 1-watt composition resistors ranging from 10 to 90 ohms should be placed across the output terminals of the Antennascope and the potentiometer adjusted for nulls on the indicating meter. The settings of the potentiometer may then be marked on a temporary paper dial and, by interpolation, 5-ohm points can be marked on the scale for the complete rotation of the control. The dial may then be removed and inked.

This calibration will hold to frequencies well above the 2-meter band, but as the internal lead inductance of the Antennascope starts to become a factor, it will no longer be possible to obtain a complete null on the indicating meter. Wired as shown, the meter null begins to rise off zero in the region of 150 MHz.

Using the Antennascope—The Antennascope is coupled to a grid-dip oscillator by means of the input link. Additional turns may need to be added to the link to obtain sufficient pickup below 7 MHz or so. Enough coupling should be obtained to allow at least $\frac{3}{4}$ -scale reading on the meter with no load connected to the measuring terminals. For general use, the measuring terminals of the instrument are connected across the antenna terminals at the feedpoint. Either a balanced or unbalanced antenna system may be measured, the "hot" lead of the unbalanced antenna connection to the ungrounded terminal of the Antennascope. Excitation is supplied from the grid-dip oscillator and the frequency of excitation and the Antennascope control dial are varied until a complete meter null is obtained. The frequency of the source of excitation now indicates the resonant frequency of the antenna under test, and the approximate radiation resistance of the antenna may be read upon the dial of the Antennascope.

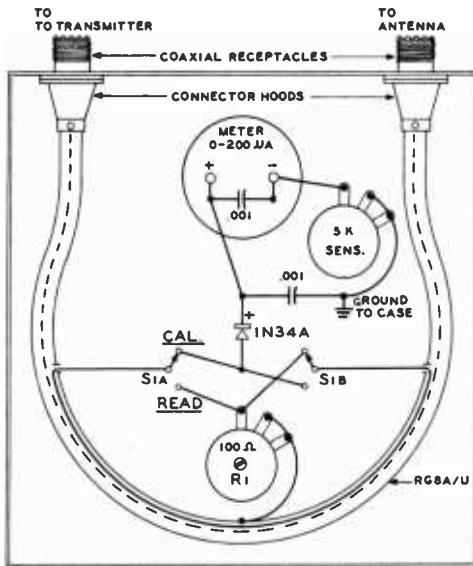

Figure 27

MONIMATCH

R₁—100-ohm composition potentiometer. Ohmite AB, or Allen Bradley type J, linear taper
S₁—Dpdt rotary switch. Centralab 1462
 Case—5" × 7" × 2" chassis with back plate.

On measurements made on 40- and 80-meter antennas it may be found impossible to obtain a complete null on the Antennascope. This is usually caused by pickup of a nearby broadcast station, in which case the rectified signal of the station will obscure the null action of the Antennascope. This action is only noticed when antennas of large size are being checked.

The Antennascope is designed to be used directly at the antenna terminals without an intervening feedline. It is convenient to mount the instrument and the grid-dip oscillator as a single package on a strip of wood. This unit may then be carried up the tower and attached to the terminals of the beam antenna. It is also possible to make remote measurements on an antenna with the use of an electrical half-wavelength of transmission line placed between the Antennascope and the antenna terminals.

The Monimatch The *Monimatch* is a dual reflectometer constructed from a length of flexible coaxial transmis-

sion line (figure 27). The heart of the Monimatch is a pickup line made from a 14-inch length of RG-8A/U coaxial cable. The coupling loop of this special section is a piece of No. 22 enamel or *formvar* covered wire slid under the flexible outer shield of the coaxial line for a distance of about eight inches. The coaxial pickup line is then conveniently wound around the inside walls of the mounting box so that the protruding ends of the coupling loop fall adjacent to the simple switching circuit. The coupling loop and center conductor of the coaxial line form a simple reflectometer terminated at either end by a noninductive potentiometer. Choice of termination is determined by the panel switch. When the potentiometer is adjusted to the balance point, the bridge is calibrated and ready for use. The selector switch permits reading forward or reverse power in the coaxial line and an SWR of unity is indicated by a null reading on the meter of the instrument.

The special coaxial pickup loop is easily made. A 14-inch length of RG-8A/U cable is trimmed square at the ends and the outer vinyl jacket is carefully removed. Two holes to pass the pickup wire are carefully made in the outer braid of the section with the aid of an awl or needle. Be careful not to break the fine wires of the braid. The holes are made 8 inches apart, and centered on the section. The outer shield is next bunched up a bit to loosen it, and a length of No. 22 wire is threaded under the braid, in and out of the holes. A stiff copper wire may be threaded through the holes and used as a needle to pass the flexible copper wire under the braid. Finally, the braid is smoothed out to its original length and the pickup wire checked with an ohmmeter to make sure that no short exists between the braid and the wire. The braid is then wrapped with vinyl tape at the two holes. The last step is to solder connector hoods and coaxial receptacles on each end of the line, making the assembly "r-f tight."

The special line may now be mounted in the instrument case, along with the various other components, as shown in the illustration. The calibrating potentiometer is mounted on an insulating plate in the center of a one-inch hole to reduce the capacity of the unit to ground. The coaxial line

should be grounded only at the coaxial receptacles, and should otherwise be wrapped with vinyl tape to prevent it from shorting to the case or other components.

A noninductive 52-ohm dummy load is attached to the output of the Monimatch and it is driven from an r-f source. Place the panel switch in the *Calibrate* position and adjust the *sensitivity* control for a half-scale reading of the meter. Now switch to the *Read* position and adjust the sensitivity control for full-scale reading. Adjust the *Calibrate* potentiometer in the back of the Monimatch for a null in the meter reading—it should be very close to zero on the scale. Switch back to *Calibrate* again and once again adjust the sensitivity control for full-scale meter reading. Finally, switch once again to *Read* and re-null the meter with the *Calibrate* potentiometer. The Monimatch is now ready for use.

Using the Monimatch—The Monimatch is inserted in the coaxial line to the antenna, power is applied and the switch set to *Calibrate* position. The sensitivity control is adjusted for full-scale reading and the switch is thrown to the *Read* position. Adjustments to the antenna may now be made to reach an SWR of unity, at which point the meter reading will be at maximum null, or close to zero. If desired, the Monimatch may be calibrated in terms of SWR by observing the reading when various values of noninductive composition resistors of known value are measured with the device.

A Practical Reflectometer The *reflectometer* is an accurate, inexpensive and easily constructed instrument for the experimenter. Shown in this section is a practical reflectometer made from a short section of coaxial transmission line. It is designed for use with output power of up to 2000 watts and at frequencies up to 150 MHz. An easily wound toroid transformer is used for a pickup element, in conjunction with two reverse-connected diode voltmeters, affording quick indication of forward and reverse conditions within the transmission line. The instrument is of the type shown in figure 21D. One voltmeter reads the incident component of voltage and the other reads the reflected component. The magnitude of standing-wave ratio on the trans-

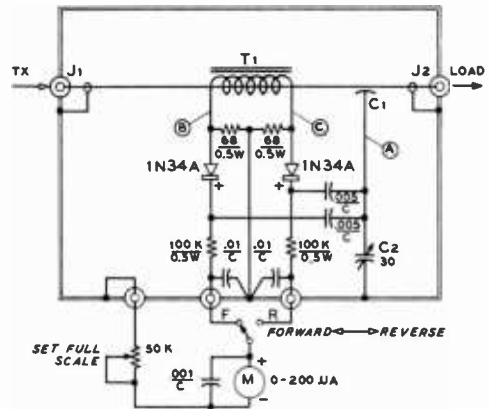

Figure 28

REFLECTOMETER

*C*₁—Sleeve formed of #28 tinned wire wrapped around inner dielectric of line for 3/8-inch length. See text

*T*₁—40 turns #28 insulated wire equally spaced around toroid core, Q-1 material. Indiana-General CF-114, 1.25" diameter × 0.38" thick. See figure 30 for assembly

mission line is the ratio of these two components.

The upper frequency limit of the reflectometer is determined by the dimensions of the pickup loop which should be a small fraction of a wavelength in size. When used to measure SWR, the resultant figure depends on the ratio of two measured voltages which are usually valid figures regardless of variations in load impedance and frequency. When used as a wattmeter, the absolute transmission-line voltage must be measured and the detection devices must have a flat frequency response with diodes operating in the square-law region for widest frequency coverage.

When used for SWR measurements, calibration of the reflectometer is not required since relative readings indicate the degree of mismatch and all system adjustments are conducted so as to make this ratio as high as possible, regardless of the absolute values. Power measurements may be made if the instrument is calibrated against a known dummy load in both the forward and reverse directions. The reflectometer may be left in the transmission line to indicate SWR and relative power output of the transmitter.

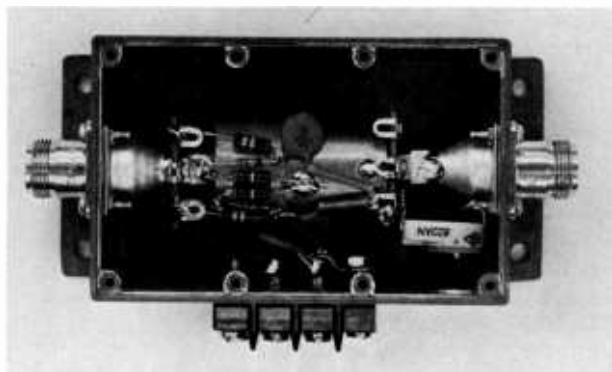

Figure 29

INTERIOR VIEW OF REFLECTOMETER

Complete assembly including accessory components is placed in cast aluminum box, 4 × 2½" × 1½" (Pomona Electronic #2904). Calibrating capacitor is adjustable through small hole drilled in box.

Building the Reflectometer—Assembly of the reflectometer is shown in figure 31. A short length of coaxial line of the chosen impedance is trimmed to length. The outer insulation and outer braid are cut with a sharp knife for a distance of about ¾ of an inch at the center of the line, exposing a section of the inner dielectric. Around the dielectric a length of No. 28 tinned wire is wound to form a sleeve about ⅜-inch long for 50-ohm cable. If 70-ohm cable is used, the sleeve should be about ⅝-inch long. The sleeve is tinned and forms capacitor C_1 to

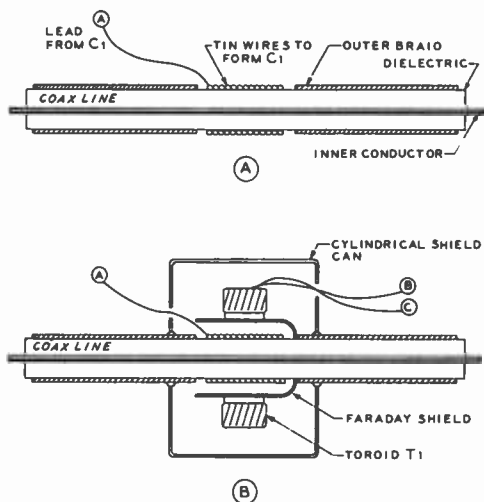

Figure 30

A—Assembly of coaxial capacitor C_1 .
B—Assembly of capacitor, Faraday shield and toroid transformer T_1 . Leads A, B, and C connect as shown in figure 28.

the inner conductor. A short length of insulated wire is soldered to the sleeve (*lead A*). The capacitor is now wrapped with vinyl tape. Next, a short section of thin copper shim stock is wrapped over the tape to form a simple Faraday shield which ensures that the coupling between the primary of T_1 (the inner conductor of the coaxial line) and the secondary (the winding on the ferrite core) is inductive and not capacitive. One end of the shield is carefully soldered to the outer braid of the coaxial line and the other end is left free.

The ferrite core is now wrapped with vinyl tape and 40 turns of No. 28 insulated wire are evenly wrapped around the core. The core is then slipped over the cable section and positioned directly above capacitor C_1 . The reflectometer section is then completed by forming a copper shield around the toroid assembly. In this case, the shield is made up of two copper discs soldered to the cable braid, over which is slipped a copper cylinder made of thin shim stock. The cylinder and end rings are soldered into an inclusive shield, as shown in the photograph, with the three pickup leads passing through small holes placed in the cylindrical end sections.

The reflectometer and associated components are placed in an aluminum box (figure 29) having a terminal strip attached for connection to an external reversal switch and meter. Final adjustment is accomplished by feeding power through the reflectometer into a dummy load having a low value of SWR and adjusting capacitor C_2 for minimum meter indication when the instrument is set for a reflected-power reading.

Figure 31

ASSEMBLY SEQUENCE OF
REFLECTOMETER UNIT

Left-to-Right—Toroid-core transformer T_1 , coaxial capacitor assembly, Faraday shield, completed unit, outer shield, transformer with attached leads.

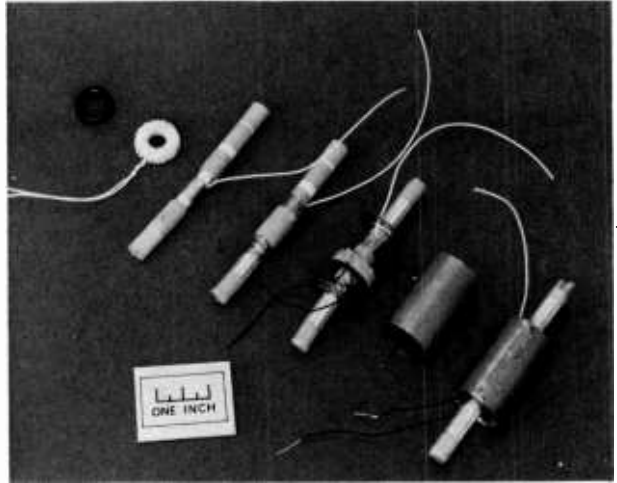

31-10 Frequency and Time Measurements

All frequency and time measurements within the United States are based on data transmitted from the *National Bureau of Standards*. Several time scales are used for time measurement: (1)—*Universal Time (UT)*. Universal time, or *Greenwich Mean Time (GMT)*, is a system of mean solar time based on the rotation of the earth about its axis relative to the position of the sun. Several UT scales are used: uncorrected astronomical observations are denoted $U\phi$; the UT time scale corrected for the earth's polar variation is denoted UT1; the UT1 scale corrected for annual variation in the rotation of the earth is denoted UT2. Time signals transmitted by standard stations are generally based on the UT2 time scale. Although UT is in common use, it is non-uniform because of changes in the earth's speed of rotation. (2)—*Ephemeris Time (ET)*. Scientific measurements of precise time intervals require a uniform time scale. The fundamental standard of constant time is defined by the orbital motion of the earth about the sun and is called Ephemeris time, and is determined from lunar observations. (3)—*Atomic Time (AT)*. Molecular and atomic resonance characteristics can be used to provide time scales which are apparently constant and nearly equivalent to ET. The designation A.1 has been given to

the time scale derived from the zero-field resonance of *cesium*. The U. S. Frequency Standard at Boulder, Colorado, is maintained by reference to the A.1 time scale.

Radio Time Signals High- and low-frequency time signals are broadcast in the United States by the *National Bureau of Standards* over radio stations WWV (located near Fort Collins, Colorado) and WWVH (located in Hawaii). These stations operate continuously on frequencies of 2.5, 5, 10, 15, 20, and 25 MHz. (WWVH = 5, 10, and 15 MHz). In addition, WWVL (20 kHz) and WWVB (60 kHz) transmit c-w signals without time ticks. The hourly broadcast schedules of WWV, WWVH, WWVB, and WWVL are shown in the chart of figure 32. Generally speaking, the h-f signals are modulated by pulses at 1 Hz, and also by standard audio frequencies alternating between 440 Hz and 600 Hz. The tones are interrupted at the beginning of the 59th minute of each hour and each five minutes thereafter for a period of one minute. Greenwich Mean Time is given in code during these intervals, followed by a voice announcement. After the announcement, propagation notices applying to transmission paths over the North Atlantic are transmitted from WWV. Transmission frequencies from WWV and WWVH are accurate to 5 parts in 10^{11} .

Technical information about the services of the NBS Standards Stations can be ob-

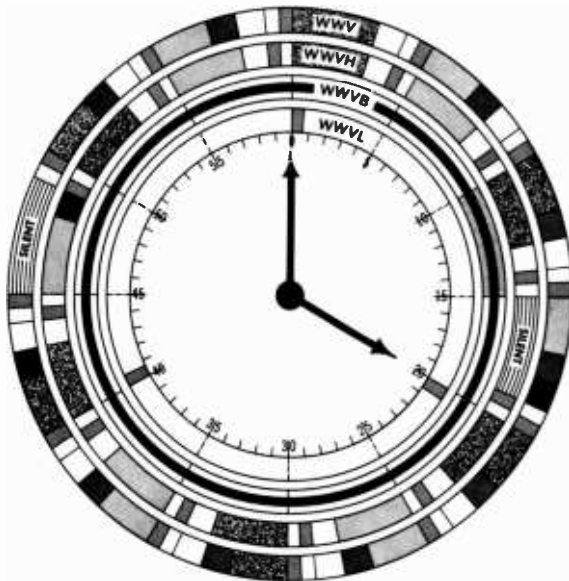









Figure 32

HOURLY BROADCAST SCHEDULES OF WWV, WWVH, WWVB, AND WWVL

SECOND PULSES -	
WWV, WWVH -	CONTINUOUS EXCEPT FOR 59TH SECOND OF EACH MINUTE AND DURING SILENT PERIODS.
WWVB -	SPECIAL TIME CODE
WWVL -	NONE
WWV - MORSE CODE - CALL LETTERS, UNIVERSAL TIME, PROPAGATION FORECAST	
VOICE-GREENWICH MEAN TIME	
MORSE CODE - FREQUENCY OFFSET (ON THE HOUR ONLY)	
WWVH - MORSE CODE CALL LETTERS, UNIVERSAL TIME, VOICE-GREENWICH MEAN TIME	
MORSE CODE - FREQUENCY OFFSET (ON THE HOUR ONLY)	
WWVB - MORSE CODE - CALL LETTERS, FREQUENCY OFFSET	
	STATION ANNOUNCEMENT
	300 PPS 1000 Hz MODULATION WWV TIMING CODE
	600 Hz TONE MODULATION
	400 Hz TONE MODULATION
	QEOALERTS
	IDENTIFICATION PHASE SHIFT
	UT-2 TIME CORRECTION
	SPECIAL TIME CODE

tained from *NBS Miscellaneous Publication 236, Standard Frequency and Time Service of the NBS*, available for 15¢ from the Superintendent of Documents, U. S. Government Printing Office, Washington, D.C. 20402.

In addition to the NBS broadcasts, the Dominion Observatory of Canada transmits time ticks and voice announcements via CHU on 3.333, 7.335, and 14.670 MHz. Many other countries of the world also transmit standard frequency signals, particularly on 10 and 15 MHz.

The standard-frequency transmissions may be used for accurately determining the limits of the various amateur bands with the aid of the station receiver and a *secondary frequency standard* which utilizes an accurate low-frequency crystal oscillator. The crystal is zero-beat with WWV by means of its harmonics and then left with only an occasional check to see that the frequency has not drifted off with time. Accurate signals at smaller frequency intervals may be derived from the secondary frequency standard by the use of multivibrator or divider circuits to produce markers at intervals of 25, 10, 5, or 1 kHz. In addition,

a variable-frequency *interpolation oscillator* may be used in conjunction with the secondary standard to measure frequencies at any point in the radio spectrum.

Simple Marker Oscillators Shown in figure 33 are four simple frequency standards that may be used with the station receiver. All units provide marker signals up to 60 MHz or better. The circuit of illustration C incorporates a series diode in the output lead to further enhance the higher harmonics of the 500-KHz crystal. Frequency correction, if required, may be achieved by either a series or parallel capacitor in the crystal circuit.

The marker oscillator may be assembled in a small metal *minibox* and is loosely coupled to the antenna of the receiver, or built on a printed-circuit board for permanent installation near the input circuit of the receiver.

31-11 Instruments for Shop and Station

A Silicon Diode Noise Generator The limiting factor in signal reception above 25 MHz is usually the thermal noise

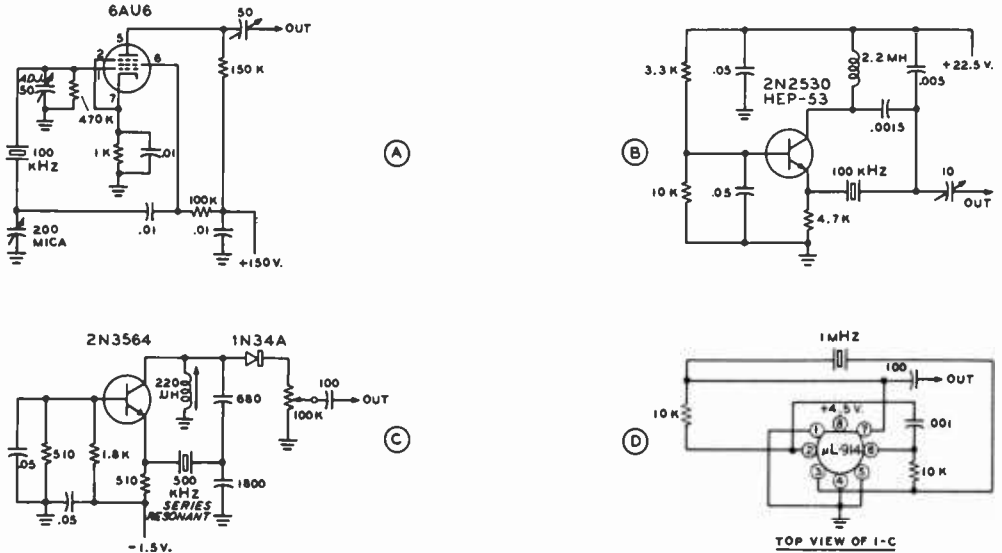

Figure 33

SECONDARY FREQUENCY STANDARDS

A—Vacuum-tube unit with frequency-correction capacitor. **B**—Transistorized 100-kHz unit. Frequency may be adjusted by capacitor across crystal. **C**—Transistorized 500-kHz oscillator with series diode to enhance harmonics. **D**—IC, 1-MHz oscillator.

generated in the receiver. At any frequency, however, the tuned circuits of the receiver must be accurately aligned for best signal-to-noise ratio. Circuit changes (and even alignment changes) in the r-f stages of a receiver may do much to either enhance or degrade the noise figure of the receiver. It is exceedingly hard to determine whether changes of either alignment or circuitry are really providing a boost in signal-to-noise ratio of the receiver, or are merely increasing the gain (and noise) of the unit.

A simple means of determining the degree of actual sensitivity of a receiver is to inject a minute signal in the input circuit and then measure the amount of this signal that is needed to overcome the inherent receiver noise. The less injected signal needed to override the receiver noise by a certain, fixed amount, the more sensitive the receiver is.

A simple source of minute signal may be obtained from a silicon crystal diode. If a small d-c current is passed through a silicon crystal in the direction of higher resistance, a small but constant r-f noise (or hiss) is

generated. The voltage necessary to generate this noise may be obtained from a few flashlight cells. The noise generator is a broadband device and requires no tuning. If built with short leads, it may be employed for receiver measurements well above 150 MHz. The noise generator should be used for comparative measurements only, since calibration against a high-quality commercial noise generator is necessary for absolute measurements.

A Practical Noise Generator Described in this section is a simple silicon-crystal noise generator. The schematic

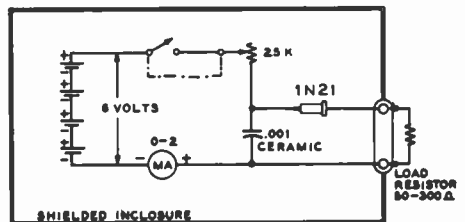

Figure 34

A SILICON DIODE NOISE GENERATOR

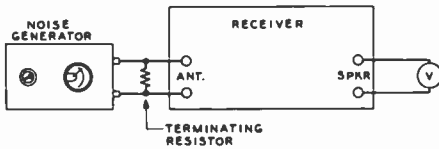

Figure 35

TEST SETUP FOR NOISE GENERATOR

of this unit is illustrated in figure 34. The 1N21 crystal and .001- μ fd ceramic capacitor are connected in series directly across the output terminals of the instrument. Three small flashlight batteries are wired in series and mounted inside the case, along with the 0-2 d-c milliammeter and the noise-level potentiometer.

To prevent heat damage to the 1N21 crystal during the soldering process, the crystal should be held with a damp rag, and the connections soldered to it quickly with a very hot iron. Across the terminals (and in parallel with the equipment to be attached to the generator) is a 1-watt carbon resistor whose resistance is equal to the impedance level at which measurements are to be made. This will usually be either 50 or 300 ohms. If the noise generator is to be used at one impedance level only, this resistor may be mounted permanently inside of the case.

Using the Noise Generator The test setup for use of the noise generator is shown in figure 35. The noise generator is connected to the antenna terminals of the receiver under test. The receiver is turned on, the avc turned off, and the r-f gain control placed full on. The audio volume control is adjusted until the output meter advances to one-quarter scale. This reading is the basic receiver noise. The noise generator is turned on, and the noise-level potentiometer adjusted until the noise output voltage of the receiver is doubled. The more resistance in the diode circuit, the better is the signal-to-noise ratio of the receiver under test. The r-f circuit of the receiver may be aligned for maximum signal-to-noise ratio with the noise generator by aligning for a 2/1 noise ratio at minimum diode current.

An Inexpensive Transistor Tester This inexpensive and compact transistor checker will measure the d-c parameters of most common transistors. Either NPN or PNP transistors may be checked. A six-position test switch permits the following parameters to be measured: (1) I_{CO} —D-c collector current when collector junction is reverse-biased and emitter is open circuited; (2) I_{CO-20} —collector current when base current is 20 microamperes; (3) I_{CO-100} —collector current when base current is 100 microamperes; (4) I_{CEO} —collector current when collector junction is reverse-biased and base is open circuited; (5) I_{CES} —collector current when collector junction is reverse-biased and base is shorted to emitter; (6) I_{EO} —emitter current when emitter junction is reverse-biased and collector is open circuited.

Using the data derived from these tests, the *static* and *a-c forward-current transfer ratios* (h_{FE} and h_{fe} respectively) may be computed as shown in figure 37. This data may be compared with the information



Figure 36

TRANSISTOR CHECKER

An expanded-scale meter provides accurate measurement of transistor parameters in this easily built instrument. Six d-c parameters may be measured and with the data derived from these tests, the a-c forward-current transfer ratios may be computed. Two transistor sockets are mounted at the left of the tester, with the three selector switches to the right. Six-position test switch is mounted to bottom side of box. Tip jacks are placed in parallel with transistor socket terminals to permit test of transistors having unorthodox bases.

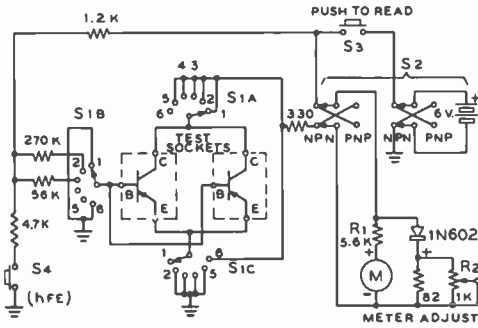

TO TEST	WHEN	ADJUST S1 TO	RESULT
I_{CO}	$V_{CB} = 0V$	1	READ METER DIRECT
I_C	$I_B = 20\mu A$	2	"
I_C	$I_B = 100\mu A$	3	"
I_{CEO}	$V_{CE} = 6V$	4	"
I_{CES}	$V_{CE} = 6V$	5	"
I_{EO}	$V_{EO} = 6V$	6	"
h_{FE}	$I_B = 20\mu A$	2	CALCULATE: $h_{FE} = \frac{I_C}{I_B} = \frac{\text{METER READING}}{20\mu A}$
h_{FE}	$I_B = 100\mu A$	3	CALCULATE: $h_{FE} = \frac{I_C}{I_B} = \frac{\text{METER READING}}{100\mu A}$
h_{fe}	$I_B = 20\mu A$	2	CALCULATE: $h_{fe} = \frac{I_{C1} - I_{C2}}{4 \times 10^{-8}}$ WHERE: I_{C1} = METER READING
h_{fe}	$I_B = 100\mu A$	3	CALCULATE: $h_{fe} = \frac{I_{C1} - I_{C2}}{20 \times 10^{-8}}$ I_{C2} = METER READING WITH S4 CLOSED
6V BATTERY	—	4	WITH 150Ω RESISTOR CONNECTED TO C-E OF TEST SOCKET, FULL-SCALE METER DEFLECTION WILL RESULT WHEN S3 IS PRESSED.

Figure 37

SCHEMATIC OF TRANSISTOR CHECKER

- S₁A, B, C—Three-pole, 6-position. Centralab 1021
- S₂, S₃, S₄—Centralab type 1400 nonshorting lever switch
- M—0-200 d-c microammeter. General Electric or Simpson (4 1/2")

listed in the transistor data sheet to determine the condition of the transistor under test.

The transistor parameters are read on a 0-100 d-c microammeter placed in a diode network which provides a nearly linear scale to 20 microamperes, a highly compressed scale from 20 microamperes to one milliamperere, and a nearly linear scale to full scale at 10 milliamperes. Transistor parameters may be read to within 10 percent on all transistor types from mesas to power alloys without switching meter ranges and without damage to the meter movement or transistor.

By making the sum of the internal resistance of the meter plus series resistor R₁ equal to about 6K, the meter scale is compressed only one microampere at 20 microamperes. Meter adjust potentiometer R₂ is set to give 10 milliamperes full-scale meter deflection. The scale may then be calibrated by comparison with a conventional meter.

If the NPN-PNP switch (S₂) is in the wrong position, the collector and emitter junctions will be forward biased during the I_{CO} and I_{EO} tests (switch positions 1 and 6). The high resulting current may be used as a check for open or intermittent connections within the transistor.

The transistor checker also measures h_{FE} with 20 microamperes and 100 microamperes base current. Depressing the h_{fe} switch (S₁) decreases the base drive about 20 percent, permitting h_{fe} to be estimated from the corresponding change in collector current (formulas 1 and 2). All tests are conducted with a 330-ohm resistor limiting the collector current to about 12 milliamperes and the maximum transistor dissipation to about 20 milliwatts. The checker therefore cannot harm a transistor regardless of how it is plugged in or how the test switches are set.

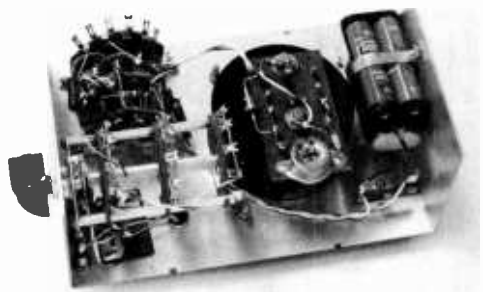

Figure 38
INTERIOR VIEW OF TRANSISTOR CHECKER

Components of meter diode circuit are mounted to phenolic board attached to meter terminals. Other small resistors may be wired directly to switch lugs. The four 1 1/2-volt batteries are held in a small clamp at the rear of the case. Chassis is cut out for lever-action switches and opening is covered with three-position switch plate.

The *battery test* provides full-scale meter deflection of 10 milliamperes when the battery potential is 6 volts. This is achieved by connecting a 150-ohm resistor from collector to emitter of a test socket.

Test Set Construction The transistor checker is built in an aluminum box measuring 3" × 5" × 7", as shown in the photographs. Test switch S_1 is mounted on the end of the box; and the transistor sockets, microammeter, and the various other switches are placed on the top of the box. Three insulated tip jacks are wired to the leads of one transistor test socket so that transistors having unorthodox bases or leads may be clipped to the tester by means of short test leads. Four 1½-volt flashlight cells are mounted to the rear of the case by an aluminum clamp. Potentiometer R_2 , the meter diode, and associated components are fastened to a phenolic board attached to the meter terminals. Switch S_1 has an indicator scale made of heavy white cardboard, lettered with India ink and a lettering pen.

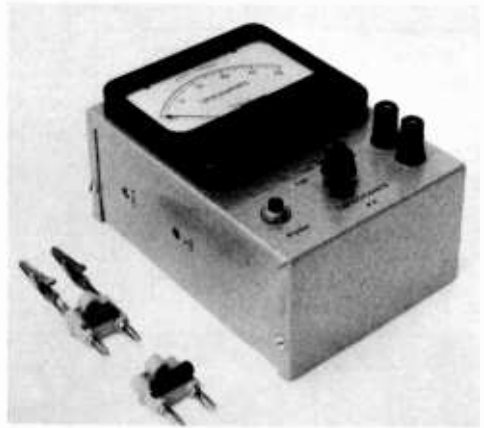

Figure 39

TRANSISTORIZED CAPACITANCE METER

This small, inexpensive test instrument measures capacitance directly up to 0.1 μfd. Using a small self-contained battery, the tester employs a single unijunction transistor in a simple oscillator counter circuit. The "unknown" terminals are at the right of the panel, with the range switch and the push-to-test button to the left. Two jack plugs are made up with "standard" capacitors. The top plug has two alligator clips soldered to jack tips which may be inserted in the tester. Calibration potentiometers are adjusted through the small holes in the side of the case.

A Transistorized Capacitance Meter Described in this section is a simple and inexpensive transistorized capacitance meter using a single unijunction transistor (figure 39). The instrument measures capacitance values ranging in size from a few pf up to 0.1 μfd in four ranges.

The capacitance meter uses a simple RC relaxation oscillator to generate square audio-frequency pulses (figure 40). The unknown capacitor is pulse-charged through a diode (D_1) and is discharged through the indicating meter and its series resistance. The discharge current is directly proportional to the value of capacitance under test provided the frequency and amplitude of the charging pulses are held constant.

The frequency of the RC oscillator is switched to provide four capacitance ranges: 100 pf, 1000 pf, .01 μfd and .1 μfd. A 0 to 50 d-c microammeter serves as a read-out device so the reading of the meter must be multiplied by two to obtain the value of measured capacitance. The base resistance of the unijunction transistor is switched

in order to achieve full-scale meter deflection on the 100-pf range.

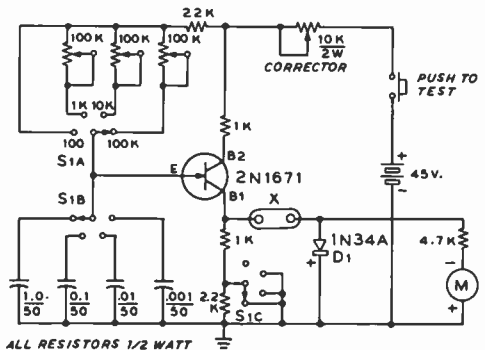

Figure 40

SCHEMATIC OF CAPACITANCE METER

S_1, A, B, C —Three-pole, 4-position. Centralab PA-1007
 M —0-50 d-c microamperes. Simpson model 49 (4½")

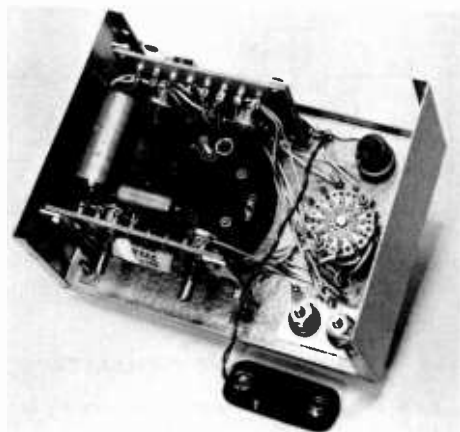

Figure 41

INTERIOR VIEW OF CAPACITANCE METER

The smaller components are mounted to phenolic terminal strips held in place by angle brackets fastened to the meter bolts. The battery is bolted to the rear of the box and connections to the instrument are made via the battery clip in the foreground.

Capacitance Meter Construction The instrument is built in an aluminum box measuring 3" × 5" × 7" (figures 39 and 41). Small components are mounted on two phenolic boards which are supported on either side of the meter by small metal angle brackets. The three 100K calibration potentiometers and the 10K corrector potentiometer are mounted on these boards so that the slotted shafts may be adjusted through small holes drilled in the sides of the case. The unijunction transistor is mounted in place by its leads. The battery is clamped to the rear half of the case with a small aluminum bracket.

Meter Calibration When the wiring has been completed and checked, the capacitance meter may be calibrated with the aid of capacitors of known value. Ten-percent tolerance paper or mica capacitors that have been checked on a capacitance bridge of good accuracy may be used, or a set of one-percent tolerance capacitors may be used as "standards." A 100-pf standard capacitor is placed between the "unknown"

terminals of the capacitance meter (marked X on the schematic) and the meter switch is set to the 100-pf range. The *press to test* button is depressed and the *corrector* potentiometer is adjusted for full-scale meter deflection. The 1000-pf capacitor is now used on the next range to achieve full-scale deflection when the 100K range-calibration potentiometer is properly adjusted. The two higher ranges are adjusted in a like manner with standard capacitors of .01 μfd and .1 μfd. The *corrector* potentiometer should be adjusted only on the 100-pf range and should not be retouched until recalibration is necessary as a result of low battery voltage. Normal battery drain is about 5 milliamperes.

A Two-Tone Audio Generator To examine linearity of an amplifier by observation of the output signal some

means must be provided to vary the output signal level from zero to maximum with a regular pattern that is easily interpreted. A simple means is to use two audio tones of equal amplitude to modulate the SSB transmitter. This is termed a *two-tone test*. This procedure causes the transmitter to emit two steady signals separated by the frequency difference of the two audio tones. The resultant, or beat, between the two r-f signals produces a pattern which, when observed on an oscilloscope has the appearance of a carrier 100-percent modulated by a series of half sine waves, as previously shown in chapter 16, figure 6B.

With a two-equal-tone test signal, the following equations approximate the relationships between two-tone meter readings, peak envelope power, and average power for class-AB or class-B operation:

D-c plate current:

$$I_h = \frac{2 \times i_{pm}}{\pi^2}$$

Plate Power Input (watts):

$$P_{in} = \frac{2 \times i_{pm} \times E_b}{\pi^2}$$

Average Power Output (watts):

$$P_o = \frac{i_{pm} \times e_p}{8}$$

Plate efficiency:

$$N_p = \left(\frac{\pi}{4}\right)^2 \times \frac{e_p}{E_b}$$

where,

- i_{pm} equals peak of the plate current pulse,
- e_p equals peak value of plate voltage swing,
- E_b equals d-c plate voltage,
- π equals 3.14

Finally, peak-envelope-power *output* under these conditions is twice the average-power output. Thus, using a two-tone test signal, a linear amplifier may be tuned up at a power-output level of half that normally achieved at the so-called "two kilowatt PEP" input level. Power-*input* level, on the other hand, of the two-tone test condition is about two-thirds that of the single-tone condition.

Shown in figure 42 is a transistor two-tone generator that may be used in conjunction with SSB equipment for appropriate tests. Two high-beta silicon NPN planar transistors are used in a twin-T dual oscillator circuit. With the values specified, frequency f_1 is about 900 Hz and frequency f_2 is about 1300 Hz. Increasing the capacitors C_1 , C_2 , and C_3 will lower the oscillator frequency. Capacitor C_1 should always equal C_2 and C_3 should have a value twice that of C_1 or C_2 . Resistor R_3 normally falls between 8K and 12K and is adjusted for best oscillator waveform. The oscillators should be tested separately and their waveform viewed on an oscilloscope.

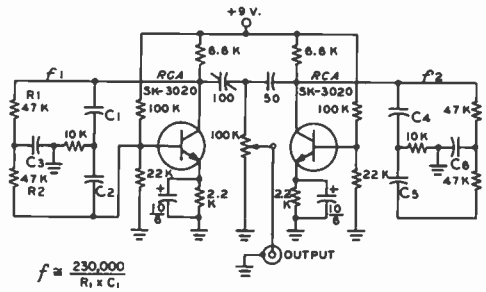

Figure 42

TWO-TONE AUDIO OSCILLATOR

Relative amplitude of oscillators may be leveled by adjusting 100-pf capacitor. For $f_1 = 900$ Hz, $C_1 = C_2 = .005 \mu\text{fd}$, and $C_3 = .01 \mu\text{fd}$. For $f_2 = 1300$ Hz, $C_4 = C_5 = .003 \mu\text{fd}$ and $C_6 = .006 \mu\text{fd}$.

The Two-tone Test—The test oscillator is connected to the audio system of the SSB transmitter which is tuned up into a dummy load with an oscilloscope coupled to the load to show a typical test pattern. The transmitter is adjusted for maximum power output without waveform flattopping. Under these conditions, the power input is:

$$\text{PEP Input (watts)} = I_b \times E_b \times \left(1.57 - 0.57 \frac{I_b}{I_o} \right)$$

where,

- E_b equals d-c plate voltage,
- I_b equals two-tone d-c plate current,
- I_o equals idling plate current with no test signal.

Workshop Practice

With a few possible exceptions, such as cabinets, brackets, neutralizing capacitors and transmitting coils, it hardly pays one to attempt to build the components required for the construction of an amateur transmitter. This is especially true when the parts are of the type used in construction and replacement work on receivers and TV, as mass production has made these parts very inexpensive.

Those who have and wish to spend the necessary time can effect considerable monetary saving in their transmitters by building them from the component parts. The necessary data is given in the construction chapters of this handbook.

To many builders, the construction is as fascinating as the operation of the finished transmitter; in fact, many amateurs get so much satisfaction out of building a well-performing piece of equipment that they spend more time constructing and rebuilding equipment than they do operating the equipment on the air.

32-1 Tools

Beautiful work can be done with metal chassis and panels with the help of only a few inexpensive tools. The time required for construction, however, will be greatly reduced if a fairly complete assortment of metal-working tools is available. Thus, while an array of tools will speed up the work,

excellent results may be accomplished with few tools, if one has the time and patience.

The investment one is justified in making in tools is dependent upon several factors. If you like to tinker, there are many tools useful in radio construction that you would probably buy anyway, or perhaps already have, such as screwdrivers, hammer, saws, square, vise, files, etc. This means that the money taken for tools from your radio budget can be used to buy the more specialized tools, such as socket punches or hole saws, taps and dies, etc.

The amount of construction work one does determines whether buying a large assortment of tools is an economical move. It also determines if one should buy the less expensive type offered at surprisingly low prices by the familiar mail order houses, "five and ten" stores, and chain auto-supply stores, or whether one should spend more money and get first-grade tools. The latter cost considerably more and work but little better when new, but will outlast several sets of the cheaper tools. Therefore they are a wise investment for the experimenter who does lots of construction work (if he can afford the initial cash outlay). The amateur who constructs only an occasional piece of apparatus need not be so concerned with tool life, as even the cheaper grade tools will last him several years, if they are given proper care.

The hand tools and materials in the accompanying lists will be found very useful

around the home workshop. Materials not listed but ordinarily used, such as paint, can best be purchased as required for each individual job.

ESSENTIAL HAND TOOLS AND MATERIALS

- 1 Good electric soldering iron, about 100 watts; or soldering gun
- 1 Spool rosin-core wire solder
- 1 Each large, medium, small, and midget screwdrivers
- 1 Good hand drill (eggbeater type), preferably two-speed
- 1 Pair regular pliers, 6 inch
- 1 Pair long-nose pliers, 6 inch
- 1 Pair cutting pliers (diagonals), 5 inch or 6 inch
- 1 $\frac{3}{8}$ -inch socket punch
- 1 "Boy Scout" knife
- 1 Combination square and steel rule, 1 foot
- 1 Yardstick or steel pushrule
- 1 Scratch awl
- 1 Center punch
- 1 Dozen or more assorted round shank drills (as many as you can afford between No. 50 and $\frac{1}{4}$ or $\frac{3}{8}$ inch, depending upon size of hand drill chuck)
- 1 Set Allen and spline-head wrenches
- 1 Set Phillips screwdrivers
- 1 Hacksaw and blades
- 1 Medium file and handle
- 1 Cold chisel ($\frac{1}{2}$ inch tip)
- 1 Wrench for socket punch
- 1 Hammer
- Light machine oil (in squirt can)
- Vinyl electrical tape

HIGHLY DESIRABLE HAND TOOLS AND MATERIALS

- 1 Bench vise (jaws at least 3 inch)
- 1 Carpenter's brace, ratchet type
- 1 Square-shank countersink bit
- 1 Square-shank taper reamer, small
- 1 Square-shank taper reamer, large (the two reamers should overlap; $\frac{1}{2}$ inch and $\frac{3}{8}$ inch size will usually be suitable)
- 1 $\frac{3}{4}$ -inch socket punch
- 1 $\frac{7}{8}$ -inch socket punch
- 1 Adjustable circle cutter for holes to 3 inch
- 1 Set small, inexpensive, open-end wrenches
- 1 Set jewelers screwdrivers

- 1 Wood chisel ($\frac{1}{2}$ inch tip)
- 1 Pair wing dividers
- 1 Coarse mill file, flat 12 inch
- 1 Coarse bastard file, round, $\frac{1}{2}$ or $\frac{3}{4}$ inch
- 1 Set nutdrivers ($\frac{1}{4}$, $\frac{5}{16}$, $\frac{11}{32}$)
- 4 Small "C" clamps
- 6 or 8 Assorted small files; round, half-round or triangular, flat, square, rat-tail
- Sandpaper and emery cloth, coarse, medium, and fine
- Epoxy cement
- File brush

USEFUL TOOLS AND MATERIALS

- 1 Jig or scroll saw (small) with metal-cutting blades
- 1 Aerosol can, contact cleaner
- 1 Wiss metal snips
- 1 Wire stripper
- 1 "Pop" rivet gun
- 1 Tap and die set for 6-32, 8-32, 10-32 and 10-24 machine screw threads
- 4 Medium size "C" clamps
- 1 Metal "nibbling" tool
- 1 Set alignment tools
- 1 Electric drill, $\frac{1}{4}$ -inch, variable speed
- 1 DYMO label embosser
- 1 Can paint thinner
- 1 Drill press
- 1 Shop vacuum cleaner
- Aerosol spray paints.
- Dusting brush
- Paint brushes
- Sheet Lucite, or polystyrene

Not listed in the table are several special-purpose radio tools which are somewhat of a luxury, but are nevertheless quite handy, such as various around-the-corner screwdrivers and wrenches, special soldering iron tips, etc. These can be found in the larger radio parts stores and are usually listed in their mail order catalogs.

Metal Chassis Though quite a few more tools and considerably more time will be required for metal-chassis construction, much neater and more satisfactory equipment can be built by mounting the parts on sheet metal chassis or circuit boards instead of "breadboards." This type of construction is necessary when shielding of the apparatus is required. A front panel

Figure 1
SOFT ALUMINUM
SHEET MAY BE CUT
WITH HEAVY
KITCHEN SHEARS

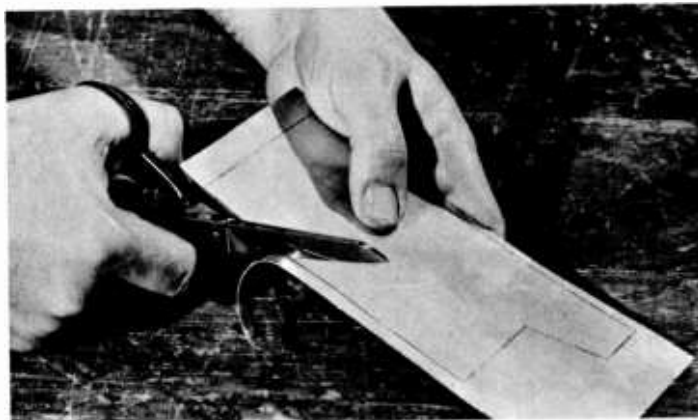

and a back shield minimize the danger of shock and complete the shielding of the inclosure.

32-2 The Material

Electronic equipment may be built on a foundation of circuit board, steel, or aluminum. The choice of foundation material is governed by the requirements of the electrical circuit, the weight of the components of the assembly, and the financial cost of the project when balanced against the pocket-book contents of the constructor.

Breadboard and Brassboard Experimental circuits may be built up in a temporary fashion termed *breadboarding*, a term reflecting the old practice of the "twenties" when circuits were built on wooden boards. Modern breadboards may be built upon circuit board material or upon prepunched phenolic boards. The prepunched boards contain a grid of small holes into which the component leads may be anchored for soldering.

A *brassboard* is an advanced form of assembly in which the experimental circuit is built up in semipermanent form on a metal

Figure 2
CONVENTIONAL
WOOD EXPANSION
BIT IS EFFECTIVE IN
DRILLING SOCKET
HOLES IN SOFT
ALUMINUM

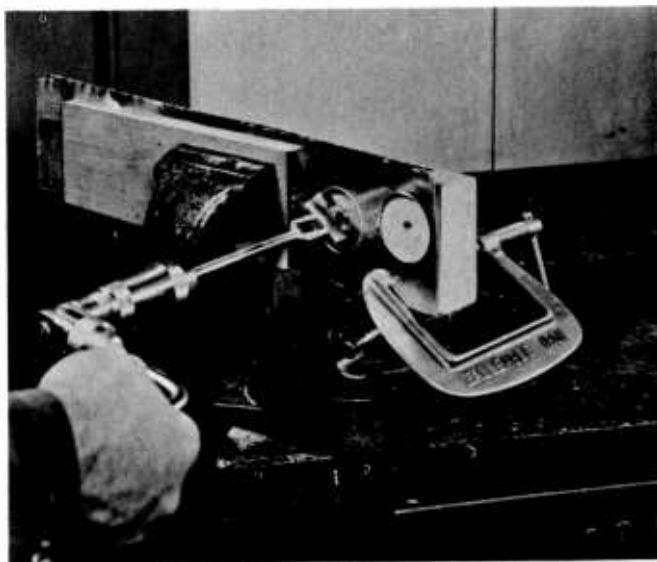



Figure 3
SOFT ALUMINUM TUBING MAY BE BENT AROUND WOODEN FORM BLOCKS. TO PREVENT THE TUBE FROM COLLAPSING ON SHARP BENDS, IT IS PACKED WITH WET SAND

chassis or copper-plated circuit board. Manufacture and use of printed-circuit boards is covered later in this chapter.

Special Frameworks For high-powered r-f stages, many amateur constructors prefer to discard the more conventional types of construction and employ

instead special metal frameworks and brackets which they design specially for the parts which they intend to use. These are usually arranged to give the shortest possible r-f leads and to fasten directly behind a panel by means of a few bolts, with the control shafts projecting through corresponding holes in the panel.



Figure 4

A WOODWORKING PLANE MAY BE USED TO SMOOTH OR TRIM THE EDGES OF ALUMINUM STOCK.

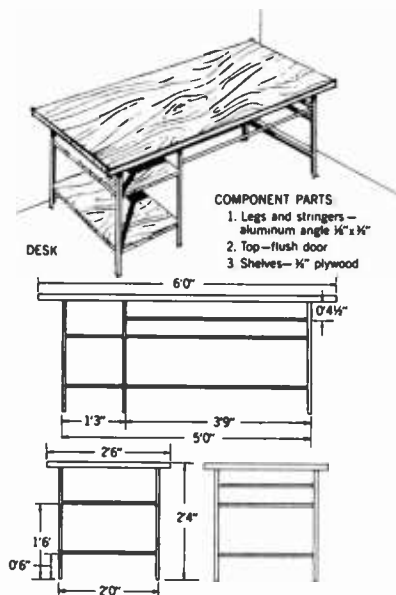

Figure 5

INEXPENSIVE OPERATING DESK MADE FROM ALUMINUM ANGLE STOCK, PLYWOOD AND A FLUSH-TYPE DOOR

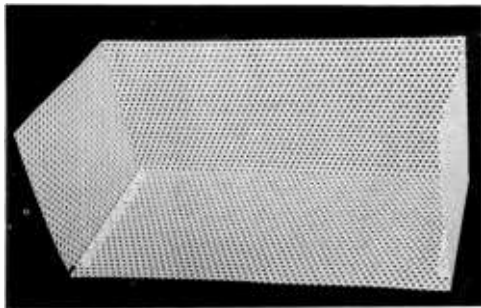

Figure 6
TVI-INCLOSURE MADE FROM
SINGLE SHEET OF
PERFORATED ALUMINUM

Reynolds Metal Co. "Do-it-yourself" aluminum sheet may be cut and folded to form TVI-proof inclosure. One-half inch lip on edges is bolted to center section with 6-32 machine screws.

Working with Aluminum The necessity of employing "electrically tight inclosures" for the containment of TVI-producing harmonics has led to the general use of aluminum for chassis, panel, and inclosure construction. If the proper type of aluminum material is used, it may be cut and worked with the usual woodworking tools found in the home shop. Hard, brittle aluminum alloys such as 2024 and 6061 should be avoided, and the softer materials such as 1100 or 3003 should be employed.

Reynold's *Do-it-Yourself* aluminum, which is being distributed on a nationwide basis through hardware stores, lumber yards, and building material outlets, is an alloy which is temper selected for easy working with ordinary tools. Aluminum sheet, bar, and angle stock may be obtained, as well as perforated sheets for ventilated inclosures.

Figures 1 through 4 illustrate how this soft material may be cut and worked with ordinary shop tools, and figure 5 shows a simple operating desk that may be made from aluminum angle stock, plywood, and a flush-type six-foot door.

32-3 TVI-Proof Inclosures

Armed with a right-angle square, tin-snips and a straight edge, the home construc-

tor will find the assembly of aluminum inclosures an easy task. This section will show simple construction methods, and short cuts in producing inclosures.

The simplest type of aluminum inclosure is that formed from a single sheet of perforated material as shown in figure 6. The top, sides, and back of the inclosure are of one piece, complete with folds that permit the formed inclosure to be bolted together along the edges. The top area of the inclosure should match the area of the chassis to ensure a close fit. The front edge of the inclosure is attached to aluminum angle strips that are bolted to the front panel of the unit; the sides and back can either be bolted to matching angle strips affixed to the chassis, or may simply be attached to the edge of the chassis with self-tapping sheet-metal screws.

A more sophisticated inclosure is shown in figure 7. In this assembly aluminum angle stock is cut to length to form a framework on which the individual sides, back, and top of the inclosure are bolted. For greatest strength, small aluminum gusset plates should be affixed in each corner of the inclosure. The complete assembly may be held together by No. 6 sheet-metal screws or "pop" rivets.

Regardless of the type of inclosure to be made, care should be taken to ensure that all joints are square. Do not assume that all prefabricated chassis and panels are absolutely true and square. Check them before you start to form your shield because any dimensional errors in the foundation will cause endless patching and cutting *after* your inclosure is bolted together. Finally, be sure that paint is removed from the panel and chassis at the point the inclosure attaches to the foundation. A clean, metallic contact along the seam is required for maximum harmonic suppression.

32-4 Inclosure Openings

Openings into shielded inclosures may be made simply by covering them by a piece of shielding held in place by sheet-metal screws.

Openings through vertical panels, however, usually require a bit more attention to prevent leakage of harmonic energy through the crack of the door which is supposed to

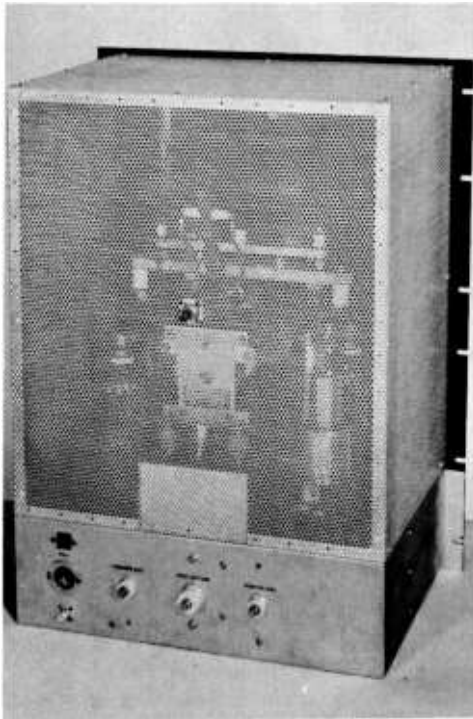

Figure 7
TVI-PROOF INCLOSURE BUILT OF
PERFORATED ALUMINUM SHEET
AND ANGLE STOCK

seal the opening. A simple way to provide a panel opening is to employ the *Bud* ventilated door rack panel *model PS-814* or *815*. The grille opening in this panel has holes small enough in area to prevent serious harmonic leakage. The actual door opening, however, does not seal tightly enough to be called TVI-proof. In areas of high TV signal strength where a minimum of operation on 28 MHz is contemplated, the door is satisfactory as-is. To accomplish more complete harmonic suppression the edges of the opening should be lined with preformed contact finger stock. *Eimac* finger stock is an excellent means of providing good contact continuity when using components with adjustable or moving contact surfaces, or in acting as electrical "weatherstrip" around access doors in inclosures. Harmonic leakage through such a sealed opening is reduced to a negligible level. The mating surface to the finger stock should be free of paint, and

should provide a good electrical connection to the stock.

32-5 Summation of the Problem

The creation of r-f energy is accompanied by harmonic generation and leakage of fundamental and harmonic energy from the generator source. For practical purposes, radio frequency power may be considered as a form of both electrical and r-f energy. As electrical energy, it will travel along any convenient conductor. As r-f energy, it will radiate directly from the source or from any conductor connected to the source. In view of this "dual personality" of r-f emanations, there is no panacea for all forms of r-f energy leakage. The cure involves both filtering and shielding: one to block the paths of conducted energy, the other to prevent the leakage of radiated energy. The proper combination of filtering and shielding can reduce the radiation of harmonic energy from a signal source some 80 decibels. In most cases, this is sufficient to eliminate interference caused by the generation of undesirable harmonics.

32-6 Construction Practice

Chassis Layout The chassis first should be covered with a layer of wrapping paper, which is drawn tightly down on all sides and fastened with scotch tape. This allows any number of measurement lines and hole centers to be spotted in the correct positions without making any marks on the chassis itself. Place on it the parts to be mounted and play a game of chess with them, trying different arrangements until all the grid and plate leads are made as short as possible, tubes are clear of coil fields, r-f chokes are in safe positions, etc. Remember, especially if you are going to use a panel, that a good mechanical layout often can accompany sound electrical design, but that the electrical design should be given first consideration.

All too often parts are grouped to give a symmetrical panel, irrespective of the arrangement behind. When a satisfactory arrangement has been reached, the mounting

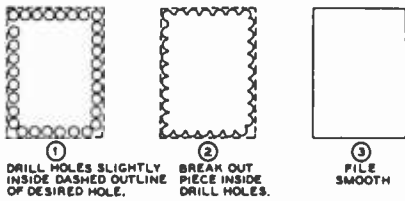

① DRILL HOLES SLIGHTLY INSIDE DASHED OUTLINE OF DESIRED HOLE.
 ② BREAK OUT PIECE INSIDE DRILL HOLES.
 ③ FILE SMOOTH

Figure 8
MAKING A RECTANGULAR CUTOUT

holes may be marked. The same procedure now must be followed for the underside, always being careful to see that there are no clashes between the two (that no top mounting screws come down into the middle of a paper capacitor on the underside, that the variable capacitor rotors do not hit anything when turned, etc.).

When all the holes have been spotted, they should be center-punched *through* the paper into the chassis. Don't forget to spot holes for leads which must also come through the chassis.

For transformers which have lugs on the bottoms, the clearance holes may be spotted by pressing the transformer on a piece of paper to obtain impressions, which may then be transferred to the chassis.

Punching In cutting socket holes, one can use either a fly-cutter or socket punches. These punches are easy to operate and only a few precautions are necessary. The guide pin should fit snugly in the guide hole. This increases the accuracy of location of the socket. If this is not of great importance, one may well use a drill of $\frac{1}{32}$ inch larger diameter than the guide pin.

The male part of the punch should be placed in the vise, cutting edge up and the female portion forced against the metal with a wrench. These punches can be obtained in sizes to accommodate all tube sockets and even large enough to be used for meter holes. In the large socket sizes they require the use of a $\frac{3}{8}$ -inch center hole to accommodate the bolt.

Transformer Cutouts Cutouts for transformers and chokes are not so simply handled. After marking off the part to be cut, drill about a $\frac{1}{4}$ -inch hole on

each of the inside corners and tangential to the edges. After burring the holes, clamp the piece and a block of cast iron or steel in the vise. Then, take your burring chisel and insert it in one of the corner holes. Cut out the metal by hitting the chisel with a hammer. The blows should be light and numerous. The chisel acts against the block in the same way that the two blades of a pair of scissors work against each other. This same process is repeated for the other sides. A file is used to trim up the completed cutout.

Figure 9
NUMBERED DRILL SIZES

DRILL NUMBER	Di- ameter (in.)	Clears Screw	Correct for Tapping Steel or Brass†
1	.228	—	—
2	.221	12-24	—
3	.213	—	14-24
4	.209	12-20	—
5	.205	—	—
6	.204	—	—
7	.201	—	—
8	.199	—	—
9	.196	—	—
10*	.193	10-32	—
11	.191	10-24	—
12*	.189	—	—
13	.185	—	—
14	.182	—	—
15	.180	—	—
16	.177	—	12-24
17	.173	—	—
18*	.169	8-32	—
19	.166	—	12-20
20	.161	—	—
21*	.159	—	10-32
22	.157	—	—
23	.154	—	—
24	.152	—	—
25*	.149	—	10-24
26	.147	—	—
27	.144	—	—
28*	.140	6-32	—
29*	.136	—	8-32
30	.128	—	—
31	.120	—	—
32	.116	—	—
33*	.113	4-36 4-40	—
34	.111	—	—
35*	.110	—	6-32
36	.106	—	—
37	.104	—	—
38	.102	—	—
39*	.100	3-48	—
40	.098	—	—
41	.096	—	—
42*	.093	—	4-36 4-40
43	.089	2-56	—
44	.086	—	—
45*	.082	—	3-48

*Sizes most commonly used in radio construction.

†Use next size larger for tapping bakelite and similar composition materials (plastics, etc.).

Another method is to drill the four corner holes large enough to take a hack saw blade, then saw instead of chisel. The four holes permit nice looking corners.

Still another method is shown in figure 8. When heavy panel steel is used and a drill press or electric drill is available, this is the most satisfactory method.

Removing Burrs In both drilling and punching, a burr is usually left on the work.

There are three simple ways of removing these. Perhaps the best is to take a chisel (be sure it is one for use on metal) and set it so that its bottom face is parallel to the piece. Then gently tap it with a hammer. This usually will make a clean job with a little practice. If one has access to a counterbore, this will also do a nice job. A countersink will work, although it bevels the edges. A drill of several sizes larger is a much used arrangement. The third method is by filing off the burr, which does a good job but scratches the adjacent metal surfaces badly.

Mounting Components There are two methods in general use for the fastening of transformers, chokes, and similar pieces of apparatus to chassis or breadboards. The first, using nuts and machine screws, is slow, and the manufacturing practice of using self-tapping screws or rivets is gaining favor. For the mounting of small parts such as resistors and capacitors, "tie points" are very useful to gain rigidity. They also contribute materially to the appearance of finished apparatus.

Rubber grommets of the proper size placed in all chassis holes through which wires are to be passed, will give a neater appearing job and also will reduce the possibility of short circuits.

Soldering Making a strong, low-resistance solder joint does not mean just dropping a blob of solder on the two parts to be joined and then hoping that they'll stick. There are several definite rules that *must* be observed.

All parts to be soldered must be absolutely clean. To clean a wire, lug, or whatever it may be, take your pocket knife and scrape it

thoroughly, until fresh metal is laid bare. It is not enough to make a few streaks; scrape until the part to be soldered is bright.

Make a good mechanical joint before applying any solder. Solder is intended primarily to make a good *electrical* connection; mechanical rigidity should be obtained by bending the wire into a small hook at the end and nipping it firmly around the other part, so that it will hold well even before the solder is applied.

Keep your iron properly tinned. It is impossible to get the work hot enough to take the solder properly if the iron is dirty. To tin your iron, file it, while hot, on one side until a full surface of clean metal is exposed. Immediately apply rosin core solder until a thin layer flows completely over the exposed, surface. Repeat for the other faces. Then take a clean rag and wipe off all excess solder and rosin. The iron should also be wiped frequently while the actual construction is going on; it helps prevent pitting the tip.

Apply the solder to the work, not to the iron. The iron should be held against the parts to be joined until they are thoroughly heated. The solder should then be applied against the parts and the iron should be held in place until the solder flows smoothly and envelops the work. If it acts like water on a greasy plate, and forms a ball, the work is not sufficiently clean.

The completed joint must be held perfectly still until the solder has had time to solidify. If the work is moved before the solder has become *completely* solid, a "cold" joint will result. This can be identified immediately, because the solder will have a dull "white" appearance rather than one of shiny "silver." Such joints tend to be of high resistance and will very likely have a bad effect on a circuit. The cure is simple, merely reheat the joint and do the job correctly.

Finishes If the apparatus is constructed on a painted chassis (commonly available in black wrinkle and gray wrinkle), there is no need for application of a protective coating when the equipment is finished, assuming that you are careful not to scratch or mar the finish while drilling holes and mounting parts. However, many amateurs prefer to use unpainted (zinc or cadmium

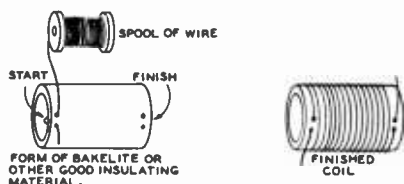

Figure 10
WINDING COIL ON INSULATING FORM

plated) chassis, because it is much simpler to make a chassis ground connection with this type of chassis. In localities near the sea coast it is a good idea to lacquer the edges of the various chassis cutouts even on a painted chassis, as rust will get a good start at these points unless the metal is protected where the drill or saw has exposed it. If too thick a coat is applied, the lacquer will tend to peel. It may be thinned with lacquer thinner to permit application of a light coat. A thin coat will adhere to any *clean* metal surface that is not too shiny.

An attractive dull gloss finish, almost velvety can be put on aluminum by sand-blasting it with a very weak blast and fine particles and then lacquering it. Soaking the aluminum in a solution of lye produces somewhat the same effect as a fine-grain sand blast.

Metal panels and inclosures may be painted an attractive color with the aid of aerosol spray paint, available in many colors. After the panel is spray-painted, press-on *decals* may be used to letter the panel. Once the decals have dried, the panel may then be given a spray coat of clear plastic or lacquer to hold the decals in position and to protect the surface.

To protect brass from tarnish, thoroughly cleanse and remove the last trace of grease by the use of paint thinner. The brass must be carefully rinsed with water and dried; but in doing it, care must be taken not to handle any portion with the bare hands or anything else that is greasy. Then apply an acrylic aerosol spray.

Winding Coils Coils are of two general types, those using a form and "air-wound" types. Neither type offers any particular constructional difficulties. Figure 10 illustrates the procedure used in form wind-

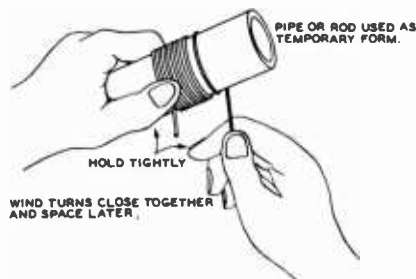

Figure 11
WINDING "AIR-SUPPORTED" COIL

ing a coil. If the winding is to be spaced, the spacing can be done either by eye or a string or another piece of wire may be wound simultaneously with the coil wire and removed after the winding is in place. The usual procedure is to clamp one end of the wire in a vise, attaching the other end to the coil form and with the coil form in hand, walk slowly toward the vise winding the wire but at the same time keeping a strong tension on the wire as the form is rotated. After the coil is wound, if there is any possibility of the turns slipping, the completed coil is either spot-coated with epoxy or model airplane cement.

Vhf and uhf coils are commonly wound of heavy enameled wire on a form and then removed from the form as in figure 11. If the coil is long or has a tendency to buckle, strips of polystyrene or a similar material may be cemented longitudinally inside the coil. Due allowance must be made for the coil springing out when removed from the form, when selecting the diameter of the form.

On air-wound coils of this type, spacing between turns is accomplished after removal from the form, by running a pencil, the shank of a screwdriver or other round object spirally between the turns from one end of the coil to the other, again making due allowance for spring.

Air-wound coils, approaching the appearance of commercially manufactured ones, can be constructed by using a round wooden form which has been sawed diagonally from end to end. Strips of insulating material are temporarily attached to this mandrel, the wire then being wound over these strips with the desired separation between turns

and cemented to the strips. When dry, the split mandrel may be removed by unwedging it.

32-7 Printed Circuits

Etched or printed circuits were developed to apply mass-production techniques to electronic assemblies, utilizing the processes of the graphic arts industry. On a large-volume basis, the etched-circuit technique provides uniformity of layout and freedom from wiring errors at a substantial reduction in assembly time and cost. In this assembly scheme, the methods of the photoengraving process are used to print photographic patterns representing electronic circuitry on copper-foil clad insulating board. By using an *etch-resistant* material (impervious to acid) for the pattern of conductors, the unmasked areas of the foil may be etched away, leaving the desired conducting pattern, conforming to the wiring harness of the electronic assembly.

The etched board is drilled at appropriate places to accept lead wires, thus permitting small components such as resistors and capacitors to be affixed to the board by inserting the leads in the matching holes. Larger components, such as sockets, inductors, and small transformers, are fitted with tabs which pass through matching holes in the board. The various components are interconnected by the foil conductors on one or both sides of the board. All joints are soldered at one time by immersing one side of the board in molten solder.

The foil-clad circuit board is usually made of laminated material such as phenolic, silicon, *teflon*, or *fiberglass*, impregnated with resin and having a copper foil of 0.0007- to 0.009-inch thickness affixed to the board under heat and pressure. Boards are available in thicknesses of $\frac{1}{16}$ to $\frac{1}{4}$ inch.

While large production runs of etched-circuit boards are made by a photographic process utilizing a master negative and photosensitive board, a simpler process may be used by experimenters to produce circuit boards in the home workshop through the use of *tape or ink resist*, plus a chemical solution which etches away all unmasked copper, without affecting the circuit board.

Homemade Circuit Boards Circuit boards may be easily constructed for electronic assemblies without the need of photographic equipment. The method is simple and fast and requires few special materials. The circuit board is made from a full-scale template of the circuit. Precut board is available from large radio supply houses as are the etchant and resist used in this process. This is how the board is prepared:

Step 1—A full-scale template of the desired circuit is drawn. Lead placement must be arranged so that the conductors do not cross each other except at interconnection points. Holes for component leads and terminals are surrounded by a foil area for the soldered connection. It is suggested that a trial layout be drawn on a piece of graph paper, making the conductors about $\frac{1}{16}$ -inch wide and the terminal circles about $\frac{1}{8}$ -inch in diameter. When conductors must cross, a point is selected where a component may be used to bridge one conductor; or a wire jumper may be added to the circuit.

Step 2—The template is transferred to the foil-clad board. The board should be unsensitized, foiled on one side only, and cut somewhat oversize. For simple circuits, the complete layout can be traced on the board by eye, using a ruler and a pencil. For more complicated circuits, the template should be applied directly to the copper side of the laminate by the use of rubber cement. The board is then lightly centerpunched at all drill points. The punched points provide convenient references for the application of the resist material. The template and cement are now removed.

Step 3—Once the board has been punched, the board is cleaned to remove copper oxide. A bright, uniform finish is required to ensure proper adhesion of the resist and complete etching. Kitchen cleaning powder may be used for this operation, followed by a thorough washing of the board in water. Care should be taken to avoid touching the copper foil from this point on. Now, to etch out the circuit on the copper foil, the resist material is applied to areas where the copper will remain, and the areas that are not covered with resist will be etched away.

Step 4—The conductors and interconnection points are laid down on the copper

laminate using resist material (figure 12). One form of resist is liquid and is applied from a resist marking pen. A second form of resist is thin vinyl tape having adhesive backing. In an emergency, India Ink or nail polish may be used for resist. Using the original templates as a visual guide, the resist is applied to the clean foil and allowed to dry.

Step 5—Suitable etchants are *ferric chloride* or *ammonium persulfate*. The etchant may be liquid, or a powder which is mixed with hot water according to directions. A Pyrex kitchen measuring glass may be used to mix and hold the etchant. A Pyrex or plastic tray is satisfactory for the mixing process and also for the etching. Drop a few glass marbles into the etching container to keep the circuit board from laying flat on the bottom. Immerse the circuit board in the etchant, and rock the tray easily back and forth so that the etching process proceeds evenly and smoothly over all exposed areas of the board. Etching time will vary from 10 to 30 minutes, depending on the strength of the etchant and thickness of the copper foil. The process may be speeded by heating the solution or by warming the immersed board with an infrared (*sun-lamp*) bulb. Once etching is complete, the board is removed from the solution and thoroughly washed in water to eliminate all traces of the etchant. Any remaining etchant may react with moisture in the air over a period of time to cause unwanted etching of the copper conductors.

Step 6—The resist material is left on the board to protect the conductors until the board is cut to final size. The board is clamped between soft wood blocks in a vise and trimmed with a fine hacksaw blade. The resist is then removed with *carbon tetrachloride* solvent and a soft cloth. (CAUTION: Do not breathe the fumes of the carbon tetrachloride.) The completed circuit is cleaned with fine steel wool to provide a clean surface for soldering. The center-punched points are now drilled with a pilot hole (use No. 54 drill) and may be drilled out to a larger size as required for component leads. The board is now complete and ready for parts assembly.

The components are mounted to the board on the side opposite the conductors. The

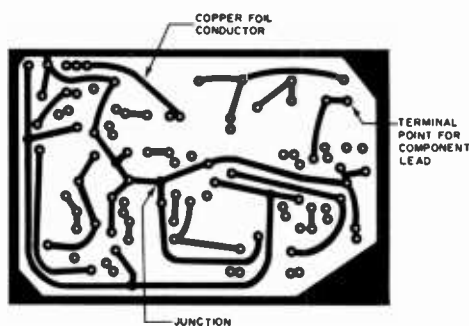

Figure 12
LIQUID RESIST MAKES
PRACTICAL PRINTED CIRCUIT

Liquid resist is applied to copper foil of circuit board to protect conductor areas from etchant. Each lead hole is circled, the circle being about four times the diameter of the hole. After the holes have been circled, lines are drawn between them in accordance with the circuit sketch. Junctions are marked with a solid circle. Connecting path should be about 1/16-inch wide, ample to carry a current of about 10 amperes, if required. Tape or a "transfer" resist material provides professional appearance to board. Placement of components may be marked on reverse of board in India Ink.

leads are passed through the appropriate holes, bent slightly to hold the component in place, and then clipped close to the conductor surface. After checking placement and observing polarity where necessary, the leads may be individually soldered to the conductor with a small pencil-tip iron. Use small diameter (0.032-inch diameter or smaller) solder and take care not to overheat the board or components during this operation. The last step is to wash the circuit side of the board with solvent to remove any soldering flux and then to give the board a coating of clear acrylic (*Krylon*) plastic spray from an aerosol can.

32-8 Coaxial Cable Terminations

Commercial electronic equipment usually employs *series N* and *series BNC* coaxial connectors, whereas the majority of amateur equipment employs the older *UHF series* coaxial connectors. Shown in figure 13 is a

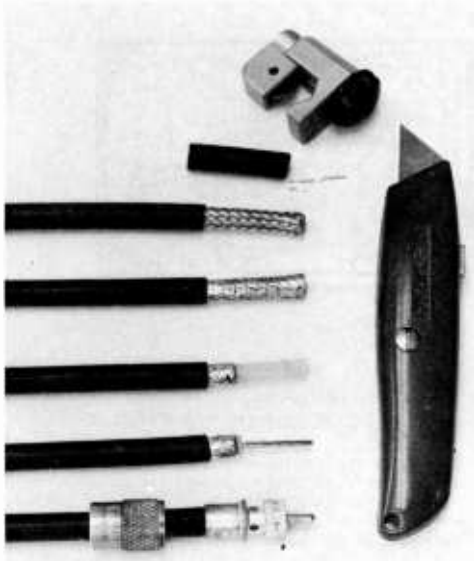

Figure 13
CABLE PREPARATION FOR PL-259
COAXIAL PLUG

Midget tubing cutter and utility knife are used to prepare RG-8/U or RG-11/U cable for uhf-type plug. Cable jacket is removed and outer braid tinned with hot iron. Braid is then cut with tubing cutter and inner insulation trimmed with knife. PL-259 shell is twisted on cable and soldered in position through holes in shank.

simplified and quick method of placing the UHF plug (PL-259) on RG-8A/U or RG-11/U coaxial line. The only special tools needed are a *Stanley 99A* (or equivalent) shop knife and a *General Hardware 123* (or equivalent) midget tubing cutter.

The first step is to slide the coupling ring of the PL-259 plug over the coaxial line. Next, the utility knife is used to circumscribe a cut in the outer, black vinyl jacket of the cable $1\frac{1}{4}$ inches back from the end. The cut should be square, and the free jacket piece is slit and removed from the cable.

Next, using a hot iron or soldering gun, quickly tin the exposed braid of the cable. Do this quickly so the inner polyethylene insulation does not soften. Clean the flux from the braid with paint thinner after the solder cools.

The next step is to cut the solid, tinned braid with the tubing cutter so that $\frac{3}{16}$ inch

remains. Mark the cutting line with a pencil and place the cutting wheel over the mark. Tighten the wheel and revolve the cutter about the cable. The unwanted braid end may be removed, using wire cutters as snips.

Next, trim the inner polyethylene insulation with the utility knife so that $\frac{1}{16}$ inch remains exposed beyond the braid. Using a circular cut, slice the insulation and pull the slug free with a twisting motion. Tin the inner conductor. The last step is to push the shell of the PL-259 plug on the prepared cable end. Screw it on with your fingers until the tinned braid is fully visible through the solder holes of the plug. Using an iron with a small point, solder the plug to the braid through the four holes, using care that the solder does not run over the outer threads of the plug. Lastly, run the coupling ring down over the plug and solder the inner conductor to the plug tip.

32-9 Shop Layout

The *size* of your workshop is relatively unimportant since the *shop layout* will determine its efficiency and the ease with which you may complete your work.

Shown in figure 14 is a workshop built into a $10' \times 10'$ area in the corner of a garage. The workbench is 32" wide, made up of four strips of $2" \times 8"$ lumber supported on a solid framework made of $2" \times 4"$ lumber. The top of the workbench is covered with hard-surface *Masonite*. The edge of the surface is protected with aluminum "counter edging" strip, obtainable at large hardware stores. Two wooden shelves 12" wide are placed above the bench to hold the various items of test equipment. The shelves are bolted to the wall studs with large angle brackets and have wooden end pieces. Along the edge of the lower shelf a metal "outlet strip" is placed that has a 117-volt outlet every six inches along its length. A similar strip is run along the *back* of the lower shelf. The front strip is used for equipment that is being bench-tested, and the rear strip powers the various items of test equipment placed on the shelves.

At the left of the bench is a storage bin for small components. A file cabinet can be placed at the right of the bench. This necessary item holds schematics, transformer



Figure 14

GOOD SHOP LAYOUT AIDS CAREFUL WORKMANSHIP

Built in a corner of a garage, this shop has all features necessary for electronic work. Test instruments are arranged on shelves above bench. Numerous outlets reduce "haywire" produced by tangled line cords. Not shown in picture are drill press and sander at end of left bench.

data sheets, and other papers that normally are lost in the usual clutter and confusion.

The area below the workbench has two storage shelves which are concealed by sliding doors made of $\frac{1}{4}$ -inch Masonite. Heavier tools, and large components are stored in this area. On the floor and not shown in the photograph is a very necessary item of shop equipment: a large trash receptacle.

32-10 Components and Hardware

Procurement of components and hardware for a construction project can often be a time consuming and vexing task as smaller radio parts stores often have limited or incomplete stocks of only the most fast-moving items. Larger distributors carrying industrial stocks, however, maintain ware-

house inventories of components or have facilities for obtaining them at short notice. It is recommended, therefore, that the experimenter have at hand catalogs from some of the larger supply houses which distribute to the electronics industry. The following industrial catalogs of large mail-order distributors are suggested as part of your technical library:

Allied Electronics Co., 100 No. Western Ave., Chicago, Ill. 60680; *Lafayette Radio Electronics*, 111 Jericho Turnpike, Syosset, N.Y. 11791; *Newark Electronics*, 500 No. Pulaski Rd., Chicago, Ill. 60624.

A complete 1700-page catalog of electronic parts and components (*The Radio Electronic Master Catalog*) may be obtained from United Technical Publications, 645 Stewart Ave., Garden City, N.Y. 11530. Copies of this master catalog are often available at large radio supply houses.

Radio Mathematics and Calculations

Radiomen often have occasion to calculate sizes and values of required parts. This requires some knowledge of mathematics. The following pages contain a review of those parts of mathematics necessary to understand and apply the information contained in this book. It is assumed that the reader has had some mathematical training; this chapter is not intended to teach those who have never learned anything of the subject.

Fortunately only a knowledge of fundamentals is necessary, although this knowledge must include several branches of the subject. Fortunately, too, the majority of practical applications in radio work reduce to the solution of equations or formulas or the interpretation of graphs.

Arithmetic

Notation of Numbers In writing numbers in the Arabic system we employ ten different symbols, digits, or figures: 1, 2, 3, 4, 5, 6, 7, 8, 9, and 0, and place them in a definite sequence. If there is more than one figure in the number the *position* of each figure or digit is as important in determining its value as is the digit itself. When we deal with whole numbers the righthandmost digit represents units, the next to the left represents tens, the next hundreds, the next thousands, from which we derive the rule that every time a digit is placed one space further to the left its value is multiplied by ten.

8	1	4	3
thousands	hundreds	tens	units

It will be seen that any number is actually a sum. In the example given above it is the sum of eight thousands, plus one hundred, plus

four tens, plus three units, which could be written as follows:

8	thousands (10 × 10 × 10)
1	hundreds (10 × 10)
4	tens
3	units
8143	

The number in the units position is sometimes referred to as a *first order* number, that in the tens position is of the *second order*, that in the hundreds position the *third order*, etc.

The idea of letting the position of the symbol denote its value is an outcome of the abacus. The abacus had only a limited number of wires with beads, but it soon became apparent that the quantity of symbols might be continued indefinitely towards the left, each further space multiplying the digit's value by ten. Thus any quantity, however large, may readily be indicated.

It has become customary for ease of reading to divide large numbers into groups of three digits, separating them by commas.

6,000,000 rather than 6000000

Our system of notation then is characterized by two things: the use of positions to indicate the value of each symbol, and the use of ten symbols, from which we derive the name *decimal system*.

Retaining the same use of positions, we might have used a different number of symbols, and displacing a symbol one place to the left might multiply its value by any other factor such as 2, 6 or 12. Such other systems have been in use in history, but will not be discussed here. There are also systems in which displacing a symbol to the left multiplies its value by

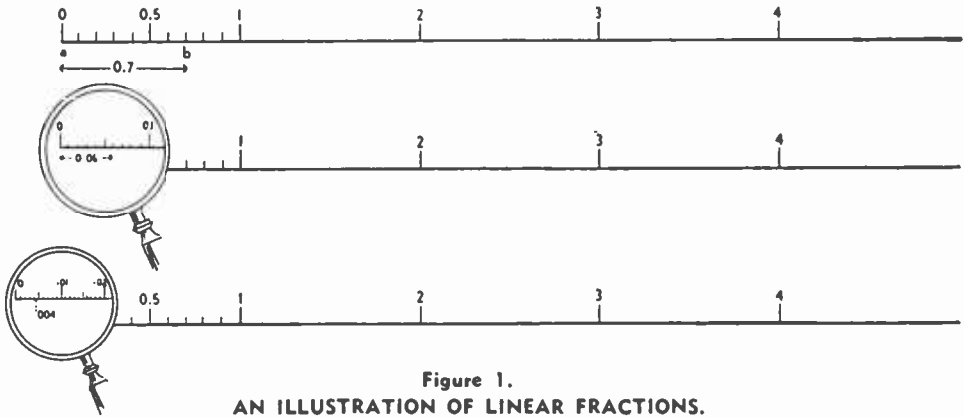

Figure 1.
AN ILLUSTRATION OF LINEAR FRACTIONS.

varying factors in accordance with complicated rules. The English system of measurements is such an inconsistent and inferior system.

Decimal Fractions Since we can extend a number indefinitely to the left to make it bigger, it is a logical step to extend it towards the right to make it smaller. Numbers smaller than unity are *fractions* and if a displacement one position to the right divides its value by ten, then the number is referred to as a *decimal fraction*. Thus a digit to the right of the units column indicates the number of *tenths*, the second digit to the right represents the number of *hundredths*, the third, the number of *thousandths*, etc. Some distinguishing mark must be used to divide unit from tenths so that one may properly evaluate each symbol. This mark is the *decimal point*.

A decimal fraction like *four-tenths* may be written .4 or 0.4 as desired, the latter probably

being the clearer. Every time a digit is placed one space further to the right it represents a ten times smaller part. This is illustrated in Figure 1, where each large division represents a unit; each unit may be divided into ten parts although in the drawing we have only so divided the first part. The length *ab* is equal to seven of these tenth parts and is written as 0.7.

The next smaller divisions, which should be written in the second column to the right of the decimal point, are each one-tenth of the small division, or one one-hundredth each. They are so small that we can only show them by imagining a magnifying glass to look at them, as in Figure 1. Six of these divisions is to be written as 0.06 (six hundredths). We need a microscope to see the next smaller division, that is those in the third place, which will be a tenth of one one-hundredth, or a thousandth; four such divisions would be written as 0.004 (four thousandths).

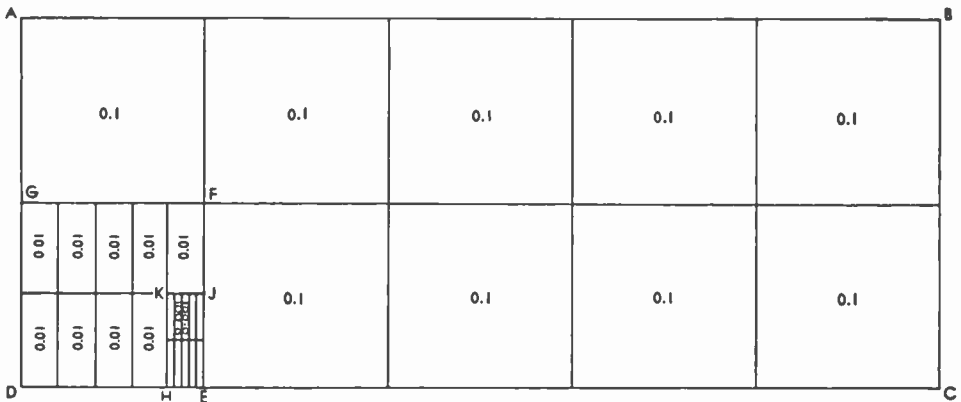

Figure 2.
IN THIS ILLUSTRATION FRACTIONAL PORTIONS ARE REPRESENTED IN THE FORM OF RECTANGLES RATHER THAN LINEARLY.
 $ABCD = 1.0$; $GFED = 0.1$; $KJEH = 0.01$; each small section within $KJEH$ equals 0.001

It should not be thought that such numbers are merely of academic interest for very small quantities are common in radio work.

Possibly the conception of fractions may be clearer to some students by representing it in the form of rectangles rather than linearly (see Figure 2).

Addition When two or more numbers are to be added we sometimes write them horizontally with the plus sign between them. + is the sign or *operator* indicating addition. Thus if 7 and 12 are to be added together we may write $7+12=19$.

But if larger or more numbers are to be added together they are almost invariably written one under another in such a position that the decimal points fall in a vertical line. If a number has no decimal point, it is still considered as being just to the right of the units figure; such a number is a whole number or *integer*. Examples:

$\begin{array}{r} 654 \\ 32 \\ \hline 53041 \end{array}$	$\begin{array}{r} 0.654 \\ 3.2 \\ \hline 53.041 \end{array}$	$\begin{array}{r} 654 \\ 32 \\ \hline 5304.1 \end{array}$
$\begin{array}{r} 53727 \\ \hline \end{array}$	$\begin{array}{r} 56.895 \\ \hline \end{array}$	$\begin{array}{r} 5990.1 \\ \hline \end{array}$

The result obtained by adding numbers is called the *sum*.

Subtraction Subtraction is the reverse of addition. Its operator is - (the *minus* sign). The number to be subtracted is called the *subtrahend*, the number from which it is subtracted is the *minuend*, and the result is called the *remainder*.

$$\begin{array}{r} \text{minuend} \\ - \text{subtrahend} \\ \hline \text{remainder} \end{array}$$

Examples:

$\begin{array}{r} 65.4 \\ - 32 \\ \hline 33.4 \end{array}$	$\begin{array}{r} 65.4 \\ - 32.21 \\ \hline 33.19 \end{array}$
--	--

Multiplication When numbers are to be multiplied together we use the ×, which is known as the *multiplication* or the *times* sign. The number to be multiplied is known as the *multiplicand* and that by which it is to be multiplied is the *multiplier*, which may be written in words as follows:

$$\begin{array}{r} \text{multiplicand} \\ \times \text{ multiplier} \\ \hline \text{partial product} \\ \text{partial product} \\ \hline \text{product} \end{array}$$

The result of the operation is called the *product*.

From the examples to follow it will be obvious that there are as many partial products as there are digits in the multiplier. In the following examples note that the righthandmost digit of each partial product is placed one space farther to the left than the previous one.

$\begin{array}{r} 834 \\ \times 26 \\ \hline 5004 \\ 1668 \\ \hline 21684 \end{array}$	$\begin{array}{r} 834 \\ \times 206 \\ \hline 5004 \\ 000 \\ 1668 \\ \hline 171804 \end{array}$
--	---

In the second example above it will be seen that the inclusion of the second partial product was unnecessary; whenever the multiplier contains a cipher (zero) the next partial product should be moved an *additional* space to the left.

Numbers containing decimal fractions may first be multiplied exactly as if the decimal point did not occur in the numbers at all; the position of the decimal point in the product is determined after all operations have been completed. It must be so positioned in the product that the number of digits to its right is equal to the number of decimal places in the multiplicand plus the number of decimal places in the multiplier.

This rule should be well understood since many radio calculations contain quantities which involve very small decimal fractions. In the examples which follow the explanatory notations "2 places," etc., are not actually written down since it is comparatively easy to determine the decimal point's proper location mentally.

$\begin{array}{r} 5.43 \\ \times 0.72 \\ \hline 1086 \\ 3801 \\ \hline 3.9096 \end{array}$	2 places 2 places 2 + 2 = 4 places
$\begin{array}{r} 0.04 \\ \times 0.003 \\ \hline 0.00012 \end{array}$	2 places 3 places 2 + 3 = 5 places

Division Division is the reverse of multiplication. Its operator is the ÷, which is called the *division* sign. It is also common to indicate division by the use of the fraction bar (/) or by writing one number over the other. The number which is to be divided is called the *dividend* and is written before the division sign or fraction bar or over the horizontal line indicating a fraction. The num-

ber by which the dividend is to be divided is called the *divisor* and follows the division sign or fraction bar or comes under the horizontal line of the *fraction*. The answer or result is called the *quotient*.

$$\begin{array}{r} \text{quotient} \\ \text{divisor} \overline{) \text{dividend}} \\ \text{or} \\ \text{dividend} \div \text{divisor} = \text{quotient} \\ \text{or} \\ \frac{\text{dividend}}{\text{divisor}} = \text{quotient} \end{array}$$

Examples:

$$\begin{array}{r} 126 \\ 834 \overline{) 105084} \\ \underline{834} \\ 2168 \\ \underline{1668} \\ 5004 \\ \underline{5004} \end{array} \qquad \begin{array}{r} 49 \\ 49 \overline{) 2436} \\ \underline{196} \\ 476 \\ \underline{441} \\ 35 \text{ remainder} \end{array}$$

Note that one number often fails to divide into another evenly. Hence there is often a quantity left over called the *remainder*.

The rules for placing the decimal point are the reverse of those for multiplication. The number of decimal places in the quotient is equal to the difference between the number of decimal places in the dividend and that in the divisor. It is often simpler and clearer to remove the decimal point entirely from the divisor by multiplying both dividend and divisor by the necessary factor; that is we move the decimal point in the divisor as many places to the right as is necessary to make it a whole number and then we move the decimal point in the dividend exactly the same number of places to the right regardless of whether this makes the dividend a whole number or not. When this has been done the decimal point in the quotient will automatically come directly above that in the dividend as shown in the following example.

Example: Divide 10.5084 by 8.34. Move the decimal point of both dividend and divisor two places to the right.

$$\begin{array}{r} 1.26 \\ 834 \overline{) 1050.84} \\ \underline{834} \\ 2168 \\ \underline{1668} \\ 5004 \\ \underline{5004} \end{array}$$

Another example: Divide 0.000325 by 0.017. Here we must move the decimal point three places to the right in both dividend and divisor.

$$\begin{array}{r} 0.019 \\ 17 \overline{) 0.325} \\ \underline{17} \\ 155 \\ \underline{153} \\ 2 \end{array}$$

In a case where the dividend has fewer decimals than the divisor the same rules still may be applied by adding ciphers. For example to divide 0.49 by 0.006 we must move the decimal point three places to the right. The 0.49 now becomes 490 and we write:

$$\begin{array}{r} 81 \\ 6 \overline{) 490} \\ \underline{48} \\ 10 \\ \underline{6} \\ 4 \end{array}$$

When the division shows a remainder it is sometimes necessary to continue the work so as to obtain more figures. In that case ciphers may be annexed to the dividend, brought down to the remainder, and the division continued as long as may be necessary; be sure to place a decimal point in the dividend before the ciphers are annexed if the dividend does not already contain a decimal point. For example:

$$\begin{array}{r} 80.33 \\ 6 \overline{) 482.00} \\ \underline{48} \\ 20 \\ \underline{18} \\ 20 \\ \underline{18} \\ 2 \end{array}$$

This operation is not very often required in radio work since the accuracy of the measurements from which our problems start seldom justifies the use of more than three significant figures. This point will be covered further later in this chapter.

Fractions Quantities of less than one (unity) are called *fractions*. They may be expressed by decimal notation as we have seen, or they may be expressed as *vulgar fractions*. Examples of vulgar fractions:

$$\frac{\text{numerator}}{\text{denominator}} \quad \frac{3}{4} \quad \frac{6}{7} \quad \frac{1}{5}$$

The upper position of a vulgar fraction is called the *numerator* and the lower position the *denominator*. When the numerator is the smaller of the two, the fraction is called a *proper fraction*; the examples of vulgar fractions given above are proper vulgar fractions. When the numerator is the larger, the expression is an *improper fraction*, which can be reduced to an integer or whole number with a proper fraction, the whole being called a mixed number. In the following examples improper fractions have been reduced to their corresponding mixed numbers.

$$\frac{7}{4} = 1\frac{3}{4} \qquad \frac{5}{3} = 1\frac{2}{3}$$

Adding or Subtracting Fractions Except when the fractions are very simple it will usually be found much easier to add and subtract fractions in the form of decimals. This rule likewise applies for practically all other operations with fractions. However, it is occasionally necessary to perform various operations with vulgar fractions and the rules should be understood.

When adding or subtracting such fractions the denominators must be made equal. This may be done by multiplying both numerator and denominator of the first fraction by the denominator of the other fraction, after which we multiply the numerator and denominator of the second fraction by the denominator of the first fraction. This sounds more complicated than it usually proves in practice, as the following examples will show.

$$\frac{1}{2} + \frac{1}{3} = \left[\frac{1 \times 3}{2 \times 3} + \frac{1 \times 2}{3 \times 2} \right] = \frac{3}{6} + \frac{2}{6} = \frac{5}{6}$$

$$\frac{3}{4} - \frac{2}{5} = \left[\frac{3 \times 5}{4 \times 5} - \frac{2 \times 4}{5 \times 4} \right] = \frac{15}{20} - \frac{8}{20} = \frac{7}{20}$$

Except in problems involving large numbers the step shown in brackets above is usually done in the head and is not written down.

Although in the examples shown above we have used proper fractions, it is obvious that the same procedure applies with improper fractions. In the case of problems involving mixed numbers it is necessary first to convert them into improper fractions. Example:

$$2\frac{3}{7} = \frac{2 \times 7 + 3}{7} = \frac{17}{7}$$

The numerator of the improper fraction is equal to the whole number multiplied by the denominator of the original fraction, to which

the numerator is added. That is in the above example we multiply 2 by 7 and then add 3 to obtain 17 for the numerator. The denominator is the same as is the denominator of the original fraction. In the following example we have added two mixed numbers.

$$2\frac{3}{7} + 3\frac{3}{4} = \frac{17}{7} + \frac{15}{4} = \left[\frac{17 \times 4}{7 \times 4} + \frac{15 \times 7}{4 \times 7} \right]$$

$$= \frac{68}{28} + \frac{105}{28} = \frac{173}{28} = 6\frac{5}{28}$$

Multiplying Fractions All vulgar fractions are multiplied by multiplying the numerators together and the denominators together, as shown in the following example:

$$\frac{3}{4} \times \frac{2}{5} = \left[\frac{3 \times 2}{4 \times 5} \right] = \frac{6}{20} = \frac{3}{10}$$

As above, the step indicated in brackets is usually not written down since it may easily be performed mentally. As with addition and subtraction any mixed numbers should be first reduced to improper fractions as shown in the following example:

$$\frac{3}{23} \times 4\frac{1}{3} = \frac{3}{23} \times \frac{13}{3} = \frac{39}{69} = \frac{13}{23}$$

Division of Fractions Fractions may be most easily divided by inverting the divisor and then multiplying.

Example:

$$\frac{2}{5} \div \frac{3}{4} = \frac{2}{5} \times \frac{4}{3} = \frac{8}{15}$$

In the above example it will be seen that to divide by $\frac{3}{4}$ is exactly the same thing as to multiply by $\frac{4}{3}$. Actual division of fractions is a rather rare operation and if necessary is usually postponed until the final answer is secured when it is often desired to reduce the resulting vulgar fraction to a decimal fraction by division. It is more common and usually results in least overall work to reduce vulgar fractions to decimals at the beginning of a problem. Examples:

$$\frac{3}{8} = 0.375 \qquad \frac{5}{32} = 0.15625$$

$$\begin{array}{r} 0.15625 \\ 32 \overline{) 5.00000} \\ \underline{32} \\ 180 \\ \underline{160} \\ 200 \\ \underline{192} \\ 80 \\ \underline{64} \\ 160 \\ \underline{160} \\ 0 \end{array}$$

It will be obvious that many vulgar fractions cannot be reduced to exact decimal equivalents. This fact need not worry us, however, since the degree of equivalence can always be as much as the data warrants. For instance, if we know that one-third of an ampere is flowing in a given circuit, this can be written as 0.333 amperes. This is not the exact equivalent of 1/3 but is close enough since it shows the value to the nearest thousandth of an ampere and it is probable that the meter from which we secured our original data was not accurate to the nearest thousandth of an ampere.

Thus in converting vulgar fractions to a decimal we unhesitatingly stop when we have reached the number of significant figures warranted by our original data, which is very seldom more than three places (see section *Significant Figures* later in this chapter).

When the denominator of a vulgar fraction contains only the factors 2 or 5, division can be brought to a finish and there will be no remainder, as shown in the examples above.

When the denominator has other factors such as 3, 7, 11, etc., the division will seldom come out even no matter how long it is continued but, as previously stated, this is of no consequence in practical work since it may be carried to whatever degree of accuracy is necessary. The digits in the quotient will usually repeat either singly or in groups, although there may first occur one or more digits which do not repeat. Such fractions are known as *repeating fractions*. They are sometimes indicated by an oblique line (fraction bar) through the digit which repeats, or through the first and last digits of a repeating group. Example:

$$\frac{1}{3} = 0.3333 \dots = 0.\overline{3}$$

$$\frac{1}{7} = 0.142857142857 \dots = 0.\overline{142857}$$

The foregoing examples contained only repeating digits. In the following example a non-repeating digit precedes the repeating digit:

$$\frac{7}{30} = 0.2333 \dots = 0.2\overline{3}$$

While repeating decimal fractions can be converted into their vulgar fraction equivalents, this is seldom necessary in practical work and the rules will be omitted here.

Powers and Roots When a number is to be multiplied by itself we say that it is to be *squared* or to be *raised to the second power*. When it is to be multiplied by itself once again, we say that it is *cubed* or *raised to the third power*.

In general terms, when a number is to be multiplied by itself we speak of *raising to a power* or *involution*; the number of times which the number is to be multiplied by itself is called the *order of the power*. The standard notation requires that the order of the power be indicated by a small number written after the number and above the line, called the *exponent*. Examples:

$$2^2 = 2 \times 2, \text{ or } 2 \text{ squared, or the second power of } 2$$

$$2^3 = 2 \times 2 \times 2, \text{ or } 2 \text{ cubed, or the third power of } 2$$

$$2^4 = 2 \times 2 \times 2 \times 2, \text{ or the fourth power of } 2$$

Sometimes it is necessary to perform the reverse of this operation, that is, it may be necessary, for instance, to find that number which multiplied by itself will give a product of nine. The answer is of course 3. This process is known as *extracting the root* or *evolution*. The particular example which is cited would be written:

$$\sqrt{9} = 3$$

The sign for extracting the root is $\sqrt{\quad}$, which is known as the *radical sign*; the order of the root is indicated by a small number above the radical as in $\sqrt[4]{\quad}$, which would mean the fourth root; this number is called the *index*. When the radical bears no index, the square or second root is intended.

Restricting our attention for the moment to square root, we know that 2 is the square root of 4, and 3 is the square root of 9. If we want the square root of a number between 3 and 9, such as the square root of 5, it is obvious that it must lie between 2 and 3. In general the square root of such a number cannot be *exactly* expressed either by a vulgar fraction or a decimal fraction. However, the square root can be carried out decimally as far as may be necessary for sufficient accuracy. In general such a decimal fraction will contain a never-ending series of digits without repeating groups. Such a number is an *irrational number*, such as

$$\sqrt{5} = 2.2361 \dots$$

The extraction of roots is usually done by tables or logarithms the use of which will be described later. There are longhand methods of extracting various roots, but we shall give only that for extracting the square root since the others become so tedious as to make other methods almost invariably preferable. Even the longhand method for extracting the square root will usually be used only if loga-

rithm tables, slide rule, or table of roots are not handy.

Extracting the Square Root First divide the number the root of which is to be extracted into groups of two digits starting at the decimal point and going in both directions. If the lefthandmost group proves to have only one digit instead of two, no harm will be done. The righthandmost group may be made to have two digits by annexing a zero if necessary. For example, let it be required to find the square root of 5678.91. This is to be divided off as follows:

$$\sqrt{56' 78.91}$$

The mark used to divide the groups may be anything convenient, although the prime-sign (') is most commonly used for the purpose.

Next find the largest square which is contained in the first group, in this case 56. The largest square is obviously 49, the square of 7. Place the 7 above the first group of the number whose root is to be extracted, which is sometimes called the *dividend* from analogy to ordinary division. Place the square of this figure, that is 49, under the first group, 56, and subtract leaving a remainder of 7.

$$\begin{array}{r} 7 \\ \sqrt{56' 78.91} \\ \underline{49} \\ 7 \end{array}$$

Bring down the next group and annex it to the remainder so that we have 778. Now to the left of this quantity write down twice the root so far found (2×7 or 14 in this example), annex a cipher as a trial divisor, and see how many times the result is contained in 778. In our example 140 will go into 778 5 times. Replace the cipher with a 5, and multiply the resulting 145 by 5 to give 725. Place the 5 directly above the second group in the dividend and then subtract the 725 from 778.

$$\begin{array}{r} 7 \quad 5 \\ \sqrt{56' 78.91} \\ \underline{49} \\ 140 \quad 7 \quad 78 \\ 145 \times 5 = \quad \underline{7 \quad 25} \\ 53 \end{array}$$

The next step is an exact repetition of the previous step. Bring down the third group and annex it to the remainder of 53, giving 5391. Write down twice the root already

found and annex the cipher (2×75 or 150 plus the cipher, which will give 1500). 1500 will go into 5391 3 times. Replace the last cipher with a three and multiply 1503 by 3 to give 4509. Place 3 above the third group. Subtract to find the remainder of 882. The quotient 75.3 which has been found so far is not the exact square root which was desired; in most cases it will be sufficiently accurate. However, if greater accuracy is desired groups of two ciphers can be brought down and the process carried on as long as necessary.

$$\begin{array}{r} 7 \quad 5 \quad 3 \\ \sqrt{56' 78.91} \\ \underline{49} \\ 140 \quad 7 \quad 78 \\ 145 \times 5 = \quad \underline{7 \quad 25} \\ 1500 \quad 53 \quad 91 \\ 1503 \times 3 = \quad \underline{45 \quad 09} \\ 8 \quad 82 \end{array}$$

Each digit of the root should be placed directly above the group of the dividend from which it was derived; if this is done the decimal point of the root will come directly above the decimal point of the dividend.

Sometimes the remainder after a square has been subtracted (such as the 1 in the following example) will not be sufficiently large to contain twice the root already found even after the next group of figures has been brought down. In this case we write a cipher above the group just brought down and bring down another group.

$$\begin{array}{r} 7 \quad 0 \quad 8 \quad 2 \\ \sqrt{50.16' 00' 00} \\ \underline{49} \\ 1400 \quad 1 \quad 16 \quad 00 \\ 1408 \times 8 = \quad \underline{1 \quad 12 \quad 64} \\ 14160 \quad 3 \quad 36 \quad 00 \\ 14162 \times 2 = \quad \underline{2 \quad 83 \quad 24} \\ 52 \quad 76 \end{array}$$

In the above example the amount 116 was not sufficient to contain twice the root already found with a cipher annexed to it; that is, it was not sufficient to contain 140. Therefore we write a zero above 16 and bring down the next group, which in this example is a pair of ciphers.

Order of Operations One frequently encounters problems in which several of the fundamental operations of arithmetic which have been described are to be performed. The order in which these operations

must be performed is important. First all powers and roots should be calculated; multiplication and division come next; adding and subtraction come last. In the example

$$2 + 3 \times 4^2$$

we must first square the 4 to get 16; then we multiply 16 by 3, making 48, and to the product we add 2, giving a result of 50.

If a different order of operations were followed, a different result would be obtained. For instance, if we add 2 to 3 we would obtain 5, and then multiplying this by the square of 4 or 16, we would obtain a result of 80, which is incorrect.

In more complicated forms such as fractions whose numerators and denominators may both be in complicated forms, the numerator and denominator are first found separately before the division is made, such as in the following example:

$$\frac{3 \times 4 + 5 \times 2}{2 \times 3 + 2 + 3} = \frac{12 + 10}{6 + 2 + 3} = \frac{22}{11} = 2$$

Problems of this type are very common in dealing with circuits containing several inductances, capacities, or resistances.

The order of operations specified above does not always meet all possible conditions; if a series of operations should be performed in a different order, this is always indicated by *parentheses* or *brackets*, for example:

$$\begin{aligned} 2 + 3 \times 4^2 &= 2 + 3 \times 16 = 2 + 48 = 50 \\ (2 + 3) \times 4^2 &= 5 \times 4^2 = 5 \times 16 = 80 \\ 2 + (3 \times 4)^2 &= 2 + 12^2 = 2 + 144 = 146 \end{aligned}$$

In connection with the radical sign, brackets may be used or the "hat" of the radical may be extended over the entire quantity whose root is to be extracted. Example:

$$\begin{aligned} \sqrt{4 + 5} &= \sqrt{4} + 5 = 2 + 5 = 7 \\ \sqrt{(4 + 5)} &= \sqrt{4 + 5} = \sqrt{9} = 3 \end{aligned}$$

It is recommended that the radical always be extended over the quantity whose root is to be extracted to avoid any ambiguity.

Cancellation In a fraction in which the numerator and denominator consist of several factors to be multiplied, considerable labor can often be saved if it is found that the same factor occurs in both numerator and denominator. These factors cancel each other and can be removed. Example:

$$\frac{\cancel{2} \times \cancel{3} \times \cancel{25}}{\cancel{6} \times \cancel{5} \times 7} = \frac{5}{7}$$

In the foregoing example it is obvious that the 3 in the numerator goes into the 6 in the denominator twice. We may thus cross out the three and replace the 6 by a 2. The 2 which we have just placed in the denominator cancels the 2 in the numerator. Next the 5 in the denominator will go into the 25 in the numerator leaving a result of 5. Now we have left only a 5 in the numerator and a 7 in the denominator, so our final result is 5/7. If we had multiplied 2 x 3 x 25 to obtain 150 and then had divided this by 6 x 5 x 7 or 210, we would have obtained the same result but, with considerably more work.

Algebra

Algebra is not a separate branch of mathematics but is merely a form of *generalized arithmetic* in which letters of the alphabet and occasional other symbols are substituted for numbers, from which it is often referred to as *literal notation*. It is simply a shorthand method of writing operations which could be spelled out.

The laws of most common electrical phenomena and circuits (including of course radio phenomena and circuits) lend themselves particularly well to representation by literal notation and solution by algebraic equations or formulas.

While we may write a particular problem in Ohm's Law as an ordinary division or multiplication, the general statement of all such problems calls for the replacement of the numbers by symbols. We might be explicit and write out the names of the units and use these names as symbols:

$$\text{volts} = \text{amperes} \times \text{ohms}$$

Such a procedure becomes too clumsy when the expression is more involved and would be unusually cumbersome if any operations like multiplication were required. Therefore as a short way of writing these generalized relations the numbers are represented by letters. Ohm's Law then becomes

$$E = I \times R$$

In the statement of any particular problem the significance of the letters is usually indicated directly below the equation or formula using them unless there can be no ambiguity. Thus the above form of Ohm's Law would be more completely written as:

$$E = I \times R$$

where $E =$ e.m.f. in volts
 $I =$ current in amperes
 $R =$ resistance in ohms

Letters therefore represent numbers, and for any letter we can read "any number." When the same letter occurs again in the same expression we would mentally read "the same number," and for another letter "another number of any value."

These letters are connected by the usual operational symbols of arithmetic, $+$, $-$, \times , \div , and so forth. In algebra, the sign for division is seldom used, a division being usually written as a fraction. The multiplication sign, \times , is usually omitted or one may write a period only. Examples:

$$2 \times a \times b = 2ab$$

$$2.3.4.5a = 2 \times 3 \times 4 \times 5 \times a$$

In practical applications of algebra, an expression usually states some physical law and each letter represents a variable quantity which is therefore called a *variable*. A fixed number in front of such a quantity (by which it is to be multiplied) is known as the *coefficient*. Sometimes the coefficient may be unknown, yet to be determined; it is then also written as a letter; k is most commonly used for this purpose.

The Negative Sign In ordinary arithmetic we seldom work with negative numbers, although we may be "short" in a subtraction. In algebra, however, a number may be either negative or positive. Such a thing may seem *academic* but a negative quantity can have a real existence. We need only refer to a *debt* being considered a negative possession. In electrical work, however, a result of a problem might be a negative number of amperes or volts, indicating that the direction of the current is opposite to the direction chosen as positive. We shall have illustrations of this shortly.

Having established the existence of negative quantities, we must now learn how to work with these negative quantities in addition, subtraction, multiplication and so forth.

In addition, a negative number added to a positive number is the same as subtracting a positive number from it.

$$\frac{7}{-3} \text{ (add) is the same as } \frac{7}{3} \text{ (subtract)}$$

or we might write it

$$7 + (-3) = 7 - 3 = 4$$

Similarly, we have:

$$a + (-b) = a - b$$

When a minus sign is in front of an expression in brackets, this minus sign has the effect of reversing the signs of every term within the brackets:

$$-(a - b) = -a + b$$

$$-(2a + 3b - 5c) = -2a - 3b + 5c$$

Multiplication. When both the multiplicand and the multiplier are negative, the product is positive. When only one (either one) is negative the product is negative. The four possible cases are illustrated below:

$$+ \times + = + \quad + \times - = -$$

$$- \times + = - \quad - \times - = +$$

Division. Since division is but the reverse of multiplication, similar rules apply for the sign of the quotient. When both the dividend and the divisor have the same sign (both negative or both positive) the quotient is positive. If they have unlike signs (one positive and one negative) the quotient is negative.

$$\frac{+}{+} = + \quad \frac{+}{-} = -$$

$$\frac{-}{-} = + \quad \frac{-}{+} = -$$

Powers. Even powers of negative numbers are positive and odd powers are negative. Powers of positive numbers are always positive. Examples:

$$-2^2 = -2 \times -2 = +4$$

$$-2^3 = -2 \times -2 \times -2 = -8$$

Roots. Since the square of a negative number is positive and the square of a positive number is also positive, it follows that a positive number has two square roots. The square root of 4 can be either $+2$ or -2 for $(+2) \times (+2) = +4$ and $(-2) \times (-2) = +4$.

Addition and Subtraction *Polynomials* are quantities like $3ab^2 + 4ab^2 - 7a^2b^4$ which have several terms of different *names*. When adding polynomials, only terms of the same name can be taken together.

$$7a^2 + 8ab^2 + 3a^2b \quad + 3$$

$$a^2 - 5ab^2 \quad - b^2$$

$$8a^2 + 3ab^2 + 3a^2b - b^2 + 3$$

Working with Powers and Roots When two powers of the same number are to be multiplied, the exponents are added.

$$a^1 \times a^1 = aa \times aaa = aaaaa = a^5 \text{ or } a^1 \times a^1 = a^{(1+1)} = a^2$$

$$b^2 \times b = b^3$$

$$c^3 \times c^1 = c^4$$

Similarly, dividing of powers is done by subtracting the exponents.

$$\frac{a^3}{a^2} = \frac{aaa}{aa} = a \text{ or } \frac{a^3}{a^2} = a^{(3-2)} = a^1 = a$$

$$\frac{b^5}{b^2} = \frac{bbbbb}{bbb} = b^3 \text{ or } \frac{b^5}{b^2} = b^{(5-2)} = b^3$$

Now we are logically led into some important new ways of notation. We have seen that when dividing, the exponents are subtracted. This can be continued into negative exponents. In the following series, we successively divide by *a* and since this can now be done in two ways, the two ways of notation must have the same meaning and be identical.

$$a^1 \qquad a^2 \qquad a^{-1} = \frac{1}{a}$$

$$a^4 \qquad a^1 = a \qquad a^{-3} = \frac{1}{a^3}$$

$$a^3 \qquad a^0 = 1 \qquad a^{-3} = \frac{1}{a^3}$$

These examples illustrate two rules: (1) any number raised to "zero" power equals one or unity; (2) any quantity raised to a negative power is the inverse or reciprocal of the same quantity raised to the same positive power.

$$a^0 = 1 \qquad a^{-n} = \frac{1}{a^n}$$

Roots. The product of the square root of two quantities equals the square root of their product.

$$\sqrt{a} \times \sqrt{b} = \sqrt{ab}$$

Also, the quotient of two roots is equal to the root of the quotient.

$$\frac{\sqrt{a}}{\sqrt{b}} = \sqrt{\frac{a}{b}}$$

Note, however, that in addition or subtraction the square root of the sum or difference is *not* the same as the sum or difference of the square roots.

$$\text{Thus, } \sqrt{9} - \sqrt{4} = 3 - 2 = 1$$

$$\text{but } \sqrt{9 - 4} = \sqrt{5} = 2.2361$$

Likewise $\sqrt{a} + \sqrt{b}$ is not the same as $\sqrt{a + b}$

Roots may be written as fractional powers. Thus \sqrt{a} may be written as $a^{1/2}$ because

$$\sqrt{a} \times \sqrt{a} = a \text{ and } a^{1/2} \times a^{1/2} = a^{1/2+1/2} = a^1 = a$$

Any root may be written in this form

$$\sqrt[n]{b} = b^{1/n} \quad \sqrt[n]{b} = b^{1/n} \quad \sqrt[n]{b^3} = b^{3/n}$$

The same notation is also extended in the negative direction:

$$b^{-1/2} = \frac{1}{b^{1/2}} = \frac{1}{\sqrt{b}} \quad c^{-1/3} = \frac{1}{c^{1/3}} = \frac{1}{\sqrt[3]{c}}$$

Following the previous rules that exponents add when powers are multiplied,

$$\sqrt{a} \times \sqrt{a} = \sqrt{a^2} \text{ but also } a^{1/2} \times a^{1/2} = a^{1/2+1/2} = a^1 \text{ therefore } a^{1/2} = \sqrt{a}$$

Powers of powers. When a power is again raised to a power, the exponents are multiplied;

$$(a^3)^2 = a^6 \qquad (b^{-1})^3 = b^{-3} \\ (a^2)^4 = a^8 \qquad (b^{-2})^{-1} = b^2$$

This same rule also applies to roots of roots and also powers of roots and roots of powers because a root can always be written as a fractional power.

$$\sqrt[3]{\sqrt{a}} = \sqrt[6]{a} \text{ for } (a^{1/2})^{1/3} = a^{1/6}$$

Removing radicals. A root or radical in the denominator of a fraction makes the expression difficult to handle. If there must be a radical it should be located in the numerator rather than in the denominator. The removal of the radical from the denominator is done by multiplying both numerator and denominator by a quantity which will remove the radical from the denominator, thus *rationalizing* it:

$$\frac{1}{\sqrt{a}} = \frac{\sqrt{a}}{\sqrt{a} \times \sqrt{a}} = \frac{1}{a} \sqrt{a}$$

Suppose we have to rationalize

$$\frac{3a}{\sqrt{a} + \sqrt{b}} \text{ In this case we must multiply}$$

numerator and denominator by $\sqrt{a} - \sqrt{b}$, the same terms but with the second having the opposite sign, so that their product will not contain a root.

$$\frac{3a}{\sqrt{a} + \sqrt{b}} = \frac{3a(\sqrt{a} - \sqrt{b})}{(\sqrt{a} + \sqrt{b})(\sqrt{a} - \sqrt{b})} = \frac{3a(\sqrt{a} - \sqrt{b})}{a - b}$$

Imaginary Numbers Since the square of a negative number is positive and the square of a positive number is also positive, the square root of a negative number can be neither positive nor negative. Such a number is said to be *imaginary*; the most common such number ($\sqrt{-1}$) is often represented by the letter *i* in mathematical work or *j* in electrical work.

$$\sqrt{-1} = i \text{ or } j \text{ and } i^2 \text{ or } j^2 = -1$$

Imaginary numbers do not exactly correspond to anything in our experience and it is best not to try to visualize them. Despite this fact, their interest is much more than academic, for they are extremely useful in many calculations involving alternating currents.

The square root of any other negative number may be reduced to a product of two roots, one positive and one negative. For instance:

$$\sqrt{-57} = \sqrt{-1} \sqrt{57} = i\sqrt{57}$$

or, in general

$$\sqrt{-a} = i\sqrt{a}$$

Since $i = \sqrt{-1}$, the powers of *i* have the following values:

$$i^2 = -1$$

$$i^3 = -1 \times i = -i$$

$$i^4 = +1$$

$$i^5 = +1 \times i = i$$

Imaginary numbers are different from either positive or negative numbers; so in addition or subtraction they must always be accounted for separately. Numbers which consist of both real and imaginary parts are called *complex* numbers. Examples of complex numbers:

$$3 + 4i = 3 + 4\sqrt{-1}$$

$$a + bi = a + b\sqrt{-1}$$

Since an imaginary number can never be equal to a real number, it follows that in an equality like

$$a + bi = c + di$$

a must equal *c* and *bi* must equal *di*

Complex numbers are handled in algebra just like any other expression, considering *i* as a known quantity. Whenever powers of *i* occur, they can be replaced by the equivalents given above. This idea of having in one equation two separate sets of quantities which must

be accounted for separately, has found a symbolic application in vector notation. These are covered later in this chapter.

Equations of the First Degree Algebraic expressions usually come in the form of equations, that is, one set of terms equals another set of terms. The simplest example of this is Ohm's Law:

$$E = IR$$

One of the three quantities may be unknown but if the other two are known, the third can be found readily by substituting the known values in the equation. This is very easy if it is *E* in the above example that is to be found; but suppose we wish to find *I* while *E* and *R* are given. We must then rearrange the equation so that *I* comes to stand alone to the left of the equality sign. This is known as *solving the equation for I*.

Solution of the equation in this case is done simply by transposing. If two things are equal then they must still be equal if both are multiplied or divided by the same number. Dividing both sides of the equation by *R*:

$$\frac{E}{R} = \frac{IR}{R} = I \text{ or } I = \frac{E}{R}$$

If it were required to solve the equation for *R*, we should divide both sides of the equation by *I*.

$$\frac{E}{I} = R \text{ or } R = \frac{E}{I}$$

A little more complicated example is the equation for the reactance of a condenser:

$$X = \frac{1}{2\pi fC}$$

To solve this equation for *C*, we may multiply both sides of the equation by *C* and divide both sides by *X*

$$X \times \frac{C}{X} = \frac{1}{2\pi fC} \times \frac{C}{X}, \text{ or}$$

$$C = \frac{1}{2\pi fX}$$

This equation is one of those which requires a good knowledge of the placing of the decimal point when solving. Therefore we give a few examples: What is the reactance of a 25 $\mu\text{mfd.}$ capacitor at 1000 kc.? In filling in the given values in the equation we must remember that the units used are farads, cycles, and ohms. Hence, we must write 25 $\mu\text{mfd.}$ as 25 millionths of a farad or 25×10^{-12} farad; similarly, 1000 kc. must be converted to 1,000,000 cycles. Substituting these values in the original equation, we have

$$X = \frac{1}{2 \times 3.14 \times 1,000,000 \times 25 \times 10^{-12}}$$

$$X = \frac{1}{6.28 \times 10^6 \times 25 \times 10^{-12}} = \frac{10^6}{6.28 \times 25}$$

$$= 6360 \text{ ohms}$$

A bias resistor of 1000 ohms should be bypassed, so that at the lowest frequency the reactance of the condenser is 1/10th of that of the resistor. Assume the lowest frequency to be 50 cycles, then the required capacity should have a reactance of 100 ohms, at 50 cycles:

$$C = \frac{1}{2 \times 3.14 \times 50 \times 100} \text{ farads}$$

$$C = \frac{10^6}{6.28 \times 5000} \text{ microfarads}$$

$$C = 32 \text{ } \mu\text{fd.}$$

In the third possible case, it may be that the frequency is the unknown. This happens for instance in some tone control problems. Suppose it is required to find the frequency which makes the reactance of a 0.03 $\mu\text{fd.}$ condenser equal to 100,000 ohms.

First we must solve the equation for f . This is done by transposition.

$$X = \frac{1}{2\pi f C} \quad f = \frac{1}{2\pi C X}$$

Substituting known values

$$f = \frac{1}{2 \times 3.14 \times 0.03 \times 10^{-4} \times 100,000} \text{ cycles}$$

$$f = \frac{1}{0.01884} \text{ cycles} = 53 \text{ cycles}$$

These equations are known as first degree equations with one unknown. First degree, because the unknown occurs only as a first power. Such an equation always has one possible solution or *root* if all the other values are known.

If there are two unknowns, a single equation will not suffice, for there are then an infinite number of possible solutions. In the case of two unknowns we need *two independent* simultaneous equations. An example of this is:

$$3x + 5y = 7 \quad 4x - 10y = 3$$

Required, to find x and y .

This type of work is done either by the *substitution method* or by the *elimination method*. In the substitution method we might write for the first equation:

$$3x = 7 - 5y \therefore x = \frac{7 - 5y}{3}$$

(The symbol \therefore means *therefore* or *hence*).

This value of x can then be substituted for x in the second equation making it a single equation with but one unknown, y .

It is, however, simpler in this case to use the elimination method. Multiply both sides of the first equation by two and add it to the second equation:

$$\begin{array}{r} 6x + 10y = 14 \\ 4x - 10y = 3 \\ \hline 10x = 17 \end{array} \text{ add} \quad x = 1.7$$

Substituting this value of x in the first equation, we have

$$5.1 + 5y = 7 \therefore 5y = 7 - 5.1 = 1.9 \therefore y = 0.38$$

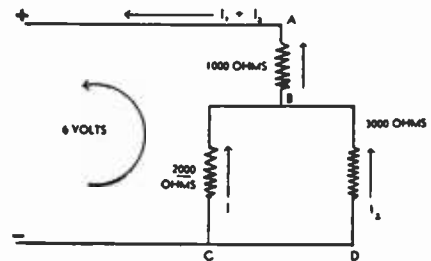

Figure 3.

In this simple network the current divides through the 2000-ohm and 3000-ohm resistors. The current through each may be found by using two simultaneous linear equations. Note that the arrows indicate the direction of electron flow as explained on page 18.

An application of two simultaneous linear equations will now be given. In Figure 3 a simple network is shown consisting of three resistances; let it be required to find the currents I_1 and I_2 in the two branches.

The general way in which all such problems can be solved is to assign directions to the currents through the various resistances. When these are chosen wrong it will do no harm for the result of the equations will then be negative, showing up the error. In this simple illustration there is, of course, no such difficulty.

Next we write the equations for the meshes, in accordance with Kirchoff's second law. All voltage drops in the direction of the curved arrow are considered positive, the reverse ones negative. Since there are two unknowns we write two equations.

$$1000 (I_1 + I_2) + 2000 I_1 = 6$$

$$-2000 I_1 + 3000 I_2 = 0$$

Expand the first equation

$$3000 I_1 + 1000 I_2 = 6$$

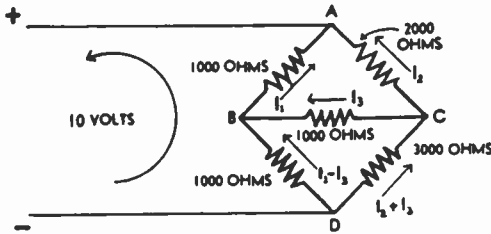

Figure 4.

A MORE COMPLICATED PROBLEM REQUIRING THE SOLUTION OF CURRENTS IN A NETWORK.

This problem is similar to that in Figure 3 but requires the use of three simultaneous linear equations.

Multiply this equation by 3

$$9000 I_1 + 3000 I_2 = 18$$

Subtracting the second equation from the first

$$11000 I_1 = 18$$

$$I_1 = 18/11000 = 0.00164 \text{ amp.}$$

Filling in this value in the second equation

$$3000 I_2 = 3.28 \quad I_2 = 0.00109 \text{ amp.}$$

A similar problem but requiring three equations is shown in Figure 4. This consists of an unbalanced bridge and the problem is to find the current in the bridge-branch, I_3 . We again assign directions to the different currents, guessing at the one marked I_1 . The voltages around closed loops ABC [eq. (1)] and BDC [eq. (2)] equal zero and are assumed to be positive in a counterclockwise direction; that from D to A equals 10 volts [eq. (3)].

$$(1) \quad -1000 I_1 + 2000 I_2 - 1000 I_3 = 0$$

$$(2) \quad -1000 (I_1 - I_2) + 1000 I_3 + 3000 (I_1 + I_3) = 0$$

$$(3) \quad 1000 I_1 + 1000 (I_1 - I_2) - 10 = 0$$

Expand equations (2) and (3)

$$(2) \quad -1000 I_1 + 3000 I_2 + 5000 I_3 = 0$$

$$(3) \quad 2000 I_1 - 1000 I_2 - 10 = 0$$

Subtract equation (2) from equation (1)

$$(a) \quad -1000 I_1 - 6000 I_2 = 0$$

Multiply the second equation by 2 and add it to the third equation

$$(b) \quad 6000 I_2 + 9000 I_2 - 10 = 0$$

Now we have but two equations with two unknowns.

Multiplying equation (a) by 6 and adding to equation (b) we have

$$-27000 I_2 - 10 = 0$$

$$I_2 = -10/27000 = -0.00037 \text{ amp.}$$

Note that now the solution is negative which means that we have drawn the arrow for I_3 in Figure 4 in the wrong direction. The current is 0.37 ma. in the other direction.

Second Degree or Quadratic Equations A somewhat similar problem in radio would be, if power in watts and resistance in ohms of a circuit are given, to find the voltage and the current. Example: When lighted to normal brilliancy, a 100 watt lamp has a resistance of 49 ohms; for what line voltage was the lamp designed and what current would it take.

Here we have to use the simultaneous equations:

$$P = EI \text{ and } E = IR$$

Filling in the known values:

$$P = EI = 100 \text{ and } E = IR = I \times 49$$

Substitute the second equation into the first equation

$$P = EI = (I) \times I \times 49 = 49 I^2 = 100$$

$$\therefore I = \sqrt{\frac{100}{49}} = \frac{10}{7} = 1.43 \text{ amp.}$$

Substituting the found value of 1.43 amp. for I in the first equation, we obtain the value of the line voltage, 70 volts.

Note that this is a *second degree* equation for we finally had the second power of I . Also, since the current in this problem could only be positive, the negative square root of $100/49$ or $-10/7$ was not used. Strictly speaking, however, there are two more values that satisfy both equations, these are -1.43 and -70 .

In general, a second degree equation in one unknown has two roots, a third degree equation three roots, etc.

The Quadratic Equation Quadratic or second degree equations with but one unknown can be reduced to the

general form:

$$ax^2 + bx + c = 0$$

where x is the unknown and a , b , and c are constants.

This type of equation can sometimes be solved by the method of factoring a three-term expression as follows:

$$2x^2 + 7x + 6 = 0$$

$$2x^2 + 4x + 3x + 6 = 0$$

factoring:

$$2x(x + 2) + 3(x + 2) = 0$$

$$(2x + 3)(x + 2) = 0$$

There are two possibilities when a product is zero. Either the one or the other factor equals zero. Therefore there are two solutions.

$$2x_1 + 3 = 0$$

$$x_1 + 2 = 0$$

$$2x_1 = -3$$

$$x_1 = -2$$

$$x_1 = -1\frac{1}{2}$$

Since factoring is not always easy, the following general solution can usually be employed; in this equation a , b , and c are the coefficients referred to above.

$$X = \frac{-b \pm \sqrt{b^2 - 4ac}}{2a}$$

Applying this method of solution to the previous example:

$$X = \frac{-7 \pm \sqrt{49 - 8 \times 6}}{4} = \frac{-7 \pm \sqrt{1}}{4} = \frac{-7 \pm 1}{4}$$

$$X_1 = \frac{-7 + 1}{4} = -1\frac{1}{2}$$

$$X_2 = \frac{-7 - 1}{4} = -2$$

A practical example involving quadratics is the law of impedance in a.c. circuits. However, this is a simple kind of quadratic equation which can be solved readily without the use of the special formula given above.

$$Z = \sqrt{R^2 + (X_L - X_C)^2}$$

This equation can always be solved for R , by squaring both sides of the equation. It should now be understood that squaring both sides of an equation as well as multiplying both sides with a term containing the unknown may add a new root. Since we know here that Z and R are positive, when we square the expression there is no ambiguity.

$$Z^2 = R^2 + (X_L - X_C)^2$$

$$\text{and } R^2 = Z^2 - (X_L - X_C)^2$$

$$\text{or } R = \sqrt{Z^2 - (X_L - X_C)^2}$$

$$\text{Also: } (X_L - X_C)^2 = Z^2 - R^2$$

$$\text{and } \pm (X_L - X_C) = \sqrt{Z^2 - R^2}$$

But here we do not know the sign of the solution unless there are other facts which indicate it. To find either X_L or X_C alone it would have to be known whether the one or the other is the larger.

Logarithms

Definition and Use A logarithm is the power (or exponent) to which we must raise one number to obtain another.

Although the large numbers used in logarithmic work may make them seem difficult or complicated, in reality the principal use of logarithms is to *simplify* calculations which would otherwise be extremely laborious.

We have seen so far that every operation in arithmetic can be reversed. If we have the addition:

$$a + b = c$$

we can reverse this operation in two ways. It may be that b is the unknown, and then we reverse the equation so that it becomes

$$c - a = b$$

It is also possible that we wish to know a , and that b and c are given. The equation then becomes

$$c - b = a$$

We call both of these reversed operations *subtraction*, and we make no distinction between the two possible reverses.

Multiplication can also be reversed in two manners. In the multiplication

$$ab = c$$

we may wish to know a , when b and c are given, or we may wish to know b when a and c are given. In both cases we speak of *division*, and we make again no distinction between the two.

In the case of powers we can also reverse the operation in two manners, but now they are not equivalent. Suppose we have the equation

$$a^b = c$$

If a is the unknown, and b and c are given, we may reverse the operation by writing

$$\sqrt[b]{c} = a$$

This operation we call *taking the root*. But there is a third possibility: that a and c are given, and that we wish to know b . In other

words, the question is "to which power must we raise a so as to obtain c ?" This operation is known as *taking the logarithm*, and b is the logarithm of c to the base a . We write this operation as follows:

$$\log_a c = b$$

Consider a numerical example. We know $2^3=8$. We can reverse this operation by asking "to which power must we raise 2 so as to obtain 8?" Therefore, the logarithm of 8 to the base 2 is 3, or

$$\log_2 8 = 3$$

Taking any single base, such as 2, we might write a series of all the powers of the base next to the series of their logarithms:

Number: 2 4 8 16 32 64 128 256 512 1024
 Logarithm: 1 2 3 4 5 6 7 8 9 10

We can expand this table by finding terms between the terms listed above. For instance, if we let the logarithms increase with $\frac{1}{2}$ each time, successive terms in the upper series would have to be multiplied by the square root of 2. Similarly, if we wish to increase the logarithm by $\frac{1}{10}$ at each term, the ratio between two consecutive terms in the upper series would be the tenth root of 2. Now this short list of numbers constitutes a small logarithm table. It should be clear that one could find the logarithm of any number to the base 2. This logarithm will usually be a number with many decimals.

Logarithmic Bases The fact that we chose 2 as a base for the illustration is purely arbitrary. Any base could be used, and therefore there are many possible systems of logarithms. In practice we use only two bases: The most frequently used base is 10, and the system using this base is known as the system of *common* logarithms, or Briggs' logarithms. The second system employs as a base an odd number, designated by the letter e ; $e = 2.71828$ This is known as the *natural* logarithmic system, also as the Napierian system, and the hyperbolic system. Although different writers may vary on the subject, the usual notation is simply $\log a$ for the common logarithm of a , and $\log_e a$ (or sometimes $\ln a$) for the natural logarithm of a . We shall use the common logarithmic system in most cases, and therefore we shall examine this system more closely.

Common Logarithms In the system wherein 10 is the base, the logarithm of 10 equals 1; the logarithm of 100 equals 2, etc., as shown in the following table:

log	10	=	log 10 ¹	=	1
log	100	=	log 10 ²	=	2
log	1,000	=	log 10 ³	=	3
log	10,000	=	log 10 ⁴	=	4
log	100,000	=	log 10 ⁵	=	5
log	1,000,000	=	log 10 ⁶	=	6

This table can be extended for numbers less than 10 when we remember the rules of powers discussed under the subject of algebra. Numbers less than unity, too, can be written as powers of ten.

log 1	=	log 10 ⁰	=	0
log 0.1	=	log 10 ⁻¹	=	-1
log 0.01	=	log 10 ⁻²	=	-2
log 0.001	=	log 10 ⁻³	=	-3
log 0.0001	=	log 10 ⁻⁴	=	-4

From these examples follow several rules: The logarithm of any number between zero and + 1 is negative; the logarithm of zero is minus infinity; the logarithm of a number greater than + 1 is positive. *Negative numbers have no logarithm.* These rules are true of common logarithms and of logarithms to any base.

The logarithm of a number between the powers of ten is an irrational number, that is, it has a never ending series of decimals. For instance, the logarithm of 20 must be between 1 and 2 because 20 is between 10 and 100; the value of the logarithm of 20 is 1.30103. . . . The part of the logarithm to the left of the decimal point is called the *characteristic*, while the decimals are called the *mantissa*. In the case of 1.30103 . . ., the logarithm of 20, the characteristic is 1 and the mantissa is .30103 . . .

Properties of Logarithms If the base of our system is ten, then, by definition of a logarithm:

$$10^{\log a} = a$$

or, if the base is raised to the power having an exponent equal to the logarithm of a number, the result is that number.

The logarithm of a *product* is equal to the *sum* of the logarithms of the two factors.

$$\log ab = \log a + \log b$$

This is easily proved to be true because, it

Figure 5. FOUR PLACE LOGARITHM TABLES.

N	Figure 5. FOUR PLACE LOGARITHM TABLES.									
	0	1	2	3	4	5	6	7	8	9
10	0000	0043	0086	0128	0170	0212	0253	0294	0334	0374
11	0414	0453	0492	0531	0569	0607	0645	0682	0719	0752
12	0792	0828	0864	0899	0934	0969	1004	1038	1072	1106
13	1139	1173	1206	1239	1271	1303	1335	1367	1399	1430
14	1461	1492	1523	1553	1584	1614	1644	1673	1703	1732
15	1761	1790	1818	1847	1875	1903	1931	1959	1987	2014
16	2041	2068	2095	2122	2148	2175	2201	2227	2253	2279
17	2304	2330	2355	2380	2405	2430	2455	2480	2504	2529
18	2553	2577	2601	2625	2648	2672	2695	2718	2742	2765
19	2788	2810	2833	2856	2878	2900	2923	2945	2967	2989
20	3010	3032	3054	3075	3096	3118	3139	3160	3181	3201
21	3222	3243	3263	3284	3304	3324	3345	3365	3385	3404
22	3424	3444	3464	3483	3502	3521	3541	3560	3579	3598
23	3617	3636	3655	3674	3692	3711	3729	3747	3766	3784
24	3802	3820	3838	3856	3874	3892	3909	3927	3945	3962
25	3979	3997	4014	4031	4048	4065	4082	4099	4116	4133
26	4150	4168	4183	4200	4218	4232	4249	4265	4281	4298
27	4314	4330	4346	4362	4378	4393	4409	4425	4440	4456
28	4472	4487	4502	4518	4533	4548	4564	4579	4594	4609
29	4624	4639	4654	4669	4683	4698	4713	4728	4742	4757
30	4771	4786	4800	4814	4829	4843	4857	4871	4886	4900
31	4914	4928	4942	4955	4969	4983	4997	5011	5024	5038
32	5051	5065	5079	5092	5105	5119	5132	5145	5159	5172
33	5185	5198	5211	5224	5237	5250	5263	5276	5289	5302
34	5315	5328	5340	5353	5366	5378	5391	5403	5416	5428
35	5441	5453	5465	5478	5490	5502	5514	5527	5539	5551
36	5563	5575	5587	5599	5611	5623	5635	5647	5658	5670
37	5682	5694	5705	5717	5729	5740	5752	5763	5775	5786
38	5798	5809	5821	5832	5843	5855	5866	5877	5888	5899
39	5911	5922	5933	5944	5955	5966	5977	5988	5999	6010
40	6021	6031	6042	6053	6064	6075	6085	6096	6107	6117
41	6128	6138	6149	6160	6170	6181	6191	6201	6212	6222
42	6232	6243	6253	6263	6274	6284	6294	6304	6314	6325
43	6335	6345	6355	6365	6375	6385	6395	6405	6415	6425
44	6435	6444	6454	6464	6474	6484	6493	6503	6513	6522
45	6532	6542	6551	6561	6571	6580	6590	6599	6609	6618
46	6628	6637	6646	6656	6665	6675	6684	6693	6702	6712
47	6721	6731	6740	6750	6759	6768	6777	6786	6795	6804
48	6812	6821	6830	6839	6848	6857	6866	6875	6884	6893
49	6902	6911	6920	6929	6937	6946	6955	6964	6972	6981
50	6990	6998	7007	7016	7024	7033	7042	7050	7059	7067
51	7076	7084	7093	7101	7110	7118	7126	7135	7143	7152
52	7160	7168	7177	7185	7193	7202	7210	7218	7226	7235
53	7243	7251	7259	7267	7275	7284	7292	7300	7308	7316
54	7324	7332	7340	7348	7356	7364	7372	7380	7388	7396
55	7404	7412	7419	7427	7435	7443	7451	7459	7466	7474
56	7482	7490	7497	7505	7513	7520	7528	7536	7543	7551
57	7559	7566	7574	7582	7590	7597	7604	7612	7619	7627
58	7634	7642	7649	7657	7664	7672	7679	7686	7694	7701
59	7709	7716	7723	7731	7738	7745	7752	7760	7767	7774
60	7782	7789	7796	7803	7810	7818	7825	7832	7839	7846
61	7853	7860	7868	7875	7882	7889	7896	7903	7910	7917
62	7924	7931	7938	7945	7952	7959	7966	7973	7980	7987
63	7993	8000	8007	8014	8021	8028	8035	8041	8048	8055
64	8062	8069	8075	8082	8089	8096	8102	8109	8116	8122
65	8129	8136	8142	8149	8156	8162	8169	8176	8182	8189
66	8195	8202	8209	8216	8222	8228	8235	8241	8248	8254
67	8261	8267	8274	8280	8287	8293	8299	8306	8312	8319
68	8325	8331	8338	8344	8351	8357	8363	8370	8376	8382
69	8388	8395	8401	8407	8414	8420	8426	8432	8439	8445
70	8451	8457	8463	8470	8476	8482	8488	8494	8500	8506
71	8513	8519	8525	8531	8537	8543	8549	8555	8561	8567
72	8573	8579	8585	8591	8597	8603	8609	8615	8621	8627
73	8632	8638	8645	8651	8657	8663	8669	8675	8681	8686
74	8692	8698	8704	8710	8716	8722	8728	8733	8739	8745
75	8751	8756	8762	8768	8774	8779	8785	8791	8797	8802
76	8808	8814	8820	8825	8831	8837	8842	8848	8854	8859
77	8865	8871	8876	8882	8887	8893	8899	8904	8910	8915
78	8921	8927	8932	8938	8943	8949	8954	8960	8965	8971
79	8976	8982	8987	8993	8998	9004	9009	9015	9020	9025
80	9031	9036	9042	9047	9053	9058	9063	9069	9074	9079
81	9085	9090	9096	9101	9106	9112	9117	9122	9128	9133
82	9138	9143	9149	9154	9159	9165	9170	9175	9180	9186
83	9191	9196	9201	9206	9212	9217	9222	9227	9232	9238
84	9243	9248	9253	9258	9263	9269	9274	9279	9284	9289
85	9294	9299	9304	9309	9315	9320	9325	9330	9335	9340
86	9345	9350	9355	9360	9365	9370	9375	9380	9385	9390
87	9395	9400	9405	9410	9415	9420	9425	9430	9435	9440
88	9445	9450	9455	9460	9465	9470	9475	9480	9485	9490
89	9494	9499	9504	9509	9513	9518	9523	9528	9533	9538
90	9542	9547	9552	9557	9562	9566	9571	9576	9581	9586
91	9590	9595	9600	9605	9609	9614	9619	9624	9628	9633
92	9638	9643	9647	9652	9657	9661	9666	9671	9675	9680
93	9685	9689	9694	9699	9703	9708	9713	9717	9722	9727
94	9731	9736	9741	9745	9750	9754	9759	9763	9768	9773
95	9777	9782	9786	9791	9795	9800	9805	9809	9814	9818
96	9823	9827	9832	9836	9841	9845	9850	9854	9859	9863
97	9868	9872	9877	9881	9886	9890	9894	9899	9903	9908
98	9912	9917	9921	9926	9930	9934	9939	9943	9948	9952
99	9956	9961	9965	9969	9974	9978	9983	9987	9991	9996

was shown before that when multiplying to powers, the exponents are added; therefore,

$$a \times b = 10^{\log a} \times 10^{\log b} = 10^{(\log a + \log b)}$$

Similarly, the logarithm of a quotient is the difference between the logarithm of the dividend and the logarithm of the divisor.

$$\log \frac{a}{b} = \log a - \log b$$

This is so because by the same rules of exponents:

$$\frac{a}{b} = \frac{10^{\log a}}{10^{\log b}} = 10^{(\log a - \log b)}$$

We have thus established an easier way of multiplication and division since these operations have been reduced to adding and subtracting.

The logarithm of a power of a number is equal to the logarithm of that number, multiplied by the exponent of the power.

$$\log a^2 = 2 \log a \text{ and } \log a^3 = 3 \log a$$

or, in general:

$$\log a^n = n \log a$$

Also, the logarithm of a root of a number is equal to the logarithm of that number divided by the index of the root:

$$\log \sqrt[n]{a} = \frac{1}{n} \log a$$

It follows from the rules of multiplication, that numbers having the same digits but different locations for the decimal point, have logarithms with the same mantissa:

- log 829 = 2.918555
- log 82.9 = 1.918555
- log 8.29 = 0.918555
- log 0.829 = -1.918555
- log 0.0829 = -2.918555

$$\log 829 = \log (8.29 \times 100) = \log 8.29 + \log 100 = 0.918555 + 2$$

Logarithm tables give the mantissas of logarithms only. The characteristic has to be determined by inspection. The characteristic is equal to the number of digits to the left of the decimal point *minus one*. In the case of logarithms of numbers less than unity, the characteristic is negative and is equal to the number of ciphers to the right of the decimal point *plus one*.

For reasons of convenience in making up

logarithm tables, it has become the rule that the mantissa should always be positive. Such notations above as -1.918555 really mean $(+0.918555 - 1)$; and -2.918555 means $(+0.918555 - 2)$. There are also some other notations in use such as

$$\bar{1}.918555 \text{ and } \bar{2}.918555$$

$$\text{also } 9.918555 - 10 \quad 8.918555 - 10 \\ 7.918555 - 10, \text{ etc.}$$

When, after some addition and subtraction of logarithms a mantissa should come out negative, one cannot look up its equivalent number or *anti-logarithm* in the table. The mantissa must first be made positive by adding and subtracting an appropriate integral number. Example: Suppose we find that the logarithm of a number is -0.34569 , then we can transform it into the proper form by adding and subtracting 1

$$\begin{array}{r} 1 \qquad -1 \\ -0.34569 \\ \hline 0.65431 -1 \text{ or } -1.65431 \end{array}$$

Using Logarithm Tables

Logarithms are used for calculations involving multiplication, division, powers, and roots. Especially when the numbers are large and for higher, or fractional powers and roots, this becomes the most convenient way.

Logarithm tables are available giving the logarithms to three places, some to four places, others to five and six places. The table to use depends on the accuracy required in the result of our calculations. The four place table, printed in this chapter, permits the finding of answers to problems to four significant figures which is good enough for most constructional purposes. If greater accuracy is required a five place table should be consulted. The five place table is perhaps the most popular of all.

Referring now to the four place table, to find a common logarithm of a number, proceed as follows. Suppose the number is 5576. First, determine the characteristic. An inspection will show that the characteristic should be 3. This figure is placed to the left of the decimal point. The mantissa is now found by reference to the logarithm table. The first two numbers are 55; glance down the *N* column until coming to these figures. Advance to the right until coming in line with the column headed 7; the mantissa will be 7459. (Note that the column headed 7 corresponds to the *third figure* in the number 5576.) Place the mantissa 7459 to the right of the decimal point, making the logarithm of 5576 now read 3.7459. *Important:* do not consider the last figure 6 in the

N	L.	0°	1	2	3	4	5	6	7	8	9	P.P.
250	39	794	811	829	846	863	881	898	915	933	950	
251		967	985	*002	*019	*037	*054	*071	*088	*106	*123	18
252	40	140	157	175	192	209	226	243	261	278	295	1 1.8
253		312	329	346	364	381	398	415	432	449	466	2 3.6
254		483	500	518	535	552	569	586	603	620	637	3 5.4
												4 7.2
255		654	671	688	705	722	739	756	773	790	807	etc.

Figure 6.

A SMALL SECTION OF A FIVE PLACE LOGARITHM TABLE.

Logarithms may be found with greater accuracy with such tables, but they are only of use when the accuracy of the original data warrants greater precision in the figure work. Slightly greater accuracy may be obtained for intermediate points by interpolation, as explained in the text.

the logarithm is -2.39811 but this is the logarithm of 0.025010 and we want the logarithm of 0.025013 . Here we can interpolate by observing that the difference between the log of 0.02501 and 0.02502 is $829 - 811$ or 18 , in the last two significant figures. Looking in the P.P. table marked 18 we find after 3 the number 5.4 which is to be added to the logarithm.

$$\begin{array}{r} -2.39811 \\ \underline{\quad\quad\quad} \\ \quad\quad\quad 5.4 \end{array}$$

-2.39816 , the logarithm of 0.025013

Since our table is only good to five places, we must eliminate the last figure given in the P.P. table if it is less than 5 , otherwise we must add one to the next to the last figure, rounding off to a whole number in the P.P. table.

Finding the anti-logarithm is done the same way but with the procedure reversed. Suppose it is required to find the anti-logarithm of 0.40100 . Find the first two digits in the column headed by L . Then one must look for the next three digits or the ones nearest to it, in the columns after 40 and on the lines from 40 to 41 . Now here we find that numbers in the neighborhood of 100 occur only with an asterisk on the line just before 40 and still after 39 . The asterisk means that instead of the 39 as the first two digits, these mantissas should have 40 as the first two digits. The logarithm 0.40100 is between the logs 0.40088 and 0.40106 ; the anti-logarithm is between 2517 and 2518 . The difference between the two logarithms in the table is again 18 in the last two figures and our logarithm 0.40100 differs with the lower one 12 in the last figures. Look in the P.P. table of 18 which number comes closest to 12 . This is found to be 12.6 for $7 \times 1.8 = 12.6$. Therefore we may add the digit 7 to the anti-logarithm already found; so we have 25177 . Next, place the decimal point according to the rules: There are as many digits to the left of the decimal point as indicated in the characteristic plus one. The anti-logarithm of 0.40100 is 2.5177 .

In the following examples of the use of logarithms we shall use only three places from the tables printed in this chapter since a greater degree of precision in our calculations would not be warranted by the accuracy of the data given.

In a 375 ohm bias resistor flows a current of 41.5 milliamperes; how many watts are dissipated by the resistor?

We write the equation for power in watts:

$$P = I^2R$$

number 5576 when looking for the mantissa in the accompanying four place tables; in fact, one may usually disregard all digits beyond the first three when determining the mantissa. (*Interpolation*, sometimes used to find a logarithm more accurately, is unnecessary unless warranted by unusual accuracy in the available data.) However, be doubly sure to include all figures when ascertaining the magnitude of the characteristic.

To find the anti-logarithm, the table is used in reverse. As an example, let us find the anti-logarithm of 1.272 or, in other words, find the number of which 1.272 is the logarithm. Look in the table for the mantissa closest to 272 . This is found in the first half of the table and the nearest value is 2718 . Write down the first two significant figures of the anti-logarithm by taking the figures at the beginning of the line on which 2718 was found. This is 18 ; add to this, the digit above the column in which 2718 was found; this is 7 . The anti-logarithm is 187 but we have not yet placed the decimal point. The characteristic is 1 , which means that there should be two digits to the left of the decimal point. Hence, 18.7 is the anti-logarithm of 1.272 .

For the sake of completeness we shall also describe the same operation with a five-place table where interpolation is done by means of tables of proportional parts (P.P. tables). Therefore we are reproducing here a small part of one page of a five-place table.

Finding the logarithm of 0.025013 is done as follows: We can begin with the characteristic, which is -2 . Next find the first three digits in the column, headed by N and immediately after this we see 39 , the first two digits of the mantissa. Then look among the headings of the other columns for the next digit of the number, in this case 1 . In the column, headed by 1 and on the line headed 250 , we find the next three digits of the logarithm, 811 . So far,

and filling in the quantities in question, we have:

$$P = 0.0415^2 \times 375$$

Taking logarithms,

$$\log P = 2 \log 0.0415 + \log 375$$

$$\log 0.0415 = -2.618$$

$$\text{So } 2 \times \log 0.0415 = -3.236$$

$$\begin{array}{r} \log \quad 375 = \quad 2.574 \\ \hline \log P \quad = -1.810 \end{array}$$

antilog = 0.646. Answer = 0.646 watts

Caution: Do not forget that the negative sign before the characteristic belongs to the characteristic only and that mantissas are *always* positive. Therefore we recommend the other notation, for it is less likely to lead to errors. The work is then written:

$$\begin{array}{r} \log 0.0415 = \quad 8.618 - 10 \\ 2 \times \log 0.0415 = 17.236 - 20 = 7.236 - 10 \\ \log 375 \quad = \quad 2.574 \\ \hline \log P \quad = \quad 9.810 - 10 \end{array}$$

Another example follows which demonstrates the ease in handling powers and roots. Assume an all-wave receiver is to be built, covering from 550 kc. to 60 mc. Can this be done in five ranges and what will be the required tuning ratio for each range if no overlapping is required? Call the tuning ratio of one band, x . Then the total tuning ratio for five such bands is x^5 . But the total tuning ratio for all bands is 60/0.55. Therefore:

$$x^5 = \frac{60}{0.55} \text{ or } : x = \sqrt[5]{\frac{60}{0.55}}$$

Taking logarithms:

$$\begin{array}{r} \log x = \frac{\log 60 - \log 0.55}{5} \\ \log 60 \quad 1.778 \\ \log 0.55 \quad -1.740 \\ \hline \quad \quad \quad 2.038 \text{ subtract} \end{array}$$

Remember again that the mantissas are positive and the characteristic alone can be negative. Subtracting -1 is the same as adding $+1$.

$$\log x = \frac{2.038}{5} = 0.408$$

$$x = \text{antilog } 0.408 = 2.56$$

The tuning ratio should be 2.56.

db	Power Ratio
0	1.00
1	1.26
2	1.58
3	2.00
4	2.51
5	3.16
6	3.98
7	5.01
8	6.31
9	7.94
10	10.00
20	100
30	1,000
40	10,000
50	100,000
60	1,000,000
70	10,000,000
80	100,000,000

Figure 7.
A TABLE OF DECIBEL GAINS VERSUS POWER RATIOS.

The Decibel

The decibel is a unit for the comparison of power or voltage levels in sound and electrical work. The sensation of our ears due to sound waves in the surrounding air is roughly proportional to the logarithm of the energy of the sound-wave and not proportional to the energy itself. For this reason a logarithmic unit is used so as to approach the reaction of the ear.

The decibel represents a *ratio* of two power levels, usually connected with gains or loss due to an amplifier or other network. The decibel is defined

$$N_{db} = 10 \log \frac{P_o}{P_i}$$

where P_o stands for the output power, P_i for the input power and N_{db} for the number of decibels. When the answer is positive, there is a gain; when the answer is negative, there is a loss.

The gain of amplifiers is usually given in decibels. For this purpose both the input power and output power should be measured. Example: Suppose that an intermediate amplifier is being driven by an input power of 0.2 watt and after amplification, the output is found to be 6 watts.

$$\frac{P_o}{P_i} = \frac{6}{0.2} = 30$$

$$\log 30 = 1.48$$

Therefore the gain is $10 \times 1.48 = 14.8$ decibels. The decibel is a logarithmic unit; when the power was multiplied by 30, the power level in decibels was increased by 14.8 decibels, or 14.8 decibels *added*.

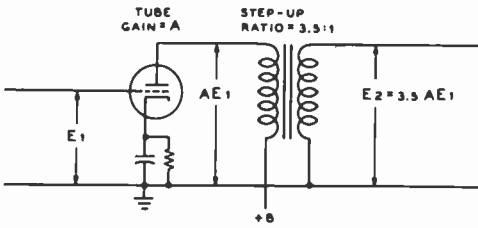

Figure 8.
STAGE GAIN.

The voltage gain in decibels in this stage is equal to the amplification in the tube plus the step-up ratio of the transformer, both expressed in decibels.

When one amplifier is to be followed by another amplifier, power gains are multiplied but the decibel gains are added. If a main amplifier having a gain of 1,000,000 (power ratio is 1,000,000) is preceded by a pre-amplifier with a gain of 1000, the total gain is 1,000,000,000. But in decibels, the first amplifier has a gain of 60 decibels, the second a gain of 30 decibels and the two of them will have a gain of 90 decibels when connected in cascade. (This is true only if the two amplifiers are properly matched at the junction as otherwise there will be a reflection loss at this point which must be subtracted from the total.)

Conversion of power ratios to decibels or vice versa is easy with the small table shown on these pages. In any case, an ordinary logarithm table will do. Find the logarithm of the power ratio and multiply by ten to find decibels.

Sometimes it is more convenient to figure decibels from voltage or current ratios or gains rather than from power ratios. This applies especially to voltage amplifiers. The equation for this is

$$N_{db} = 20 \log \frac{E_o}{E_i} \text{ or } 20 \log \frac{I_o}{I_i}$$

where the subscript, *o*, denotes the output voltage or current and *i*, the input voltage or current. Remember, this equation is true only if the voltage or current gain in question represents a power gain which is the square of it and not if the power gain which results from this is some other quantity due to impedance changes. This should be quite clear when we consider that a matching transformer to connect a speaker to a line or output tube does not represent a gain or loss; there is a voltage change and a current change yet the power remains the same for the impedance has changed.

On the other hand, when dealing with voltage amplifiers, we can figure the gain in a stage by finding the voltage ratio from the grid of the first tube to the grid of the next tube.

Example: In the circuit of Figure 8, the gain in the stage is equal to the amplification in the tube and the step-up ratio of the transformer. If the amplification in the tube is 10 and the step-up in the transformer is 3.5, the voltage gain is 35 and the gain in decibels is:

$$20 \times \log 35 = 20 \times 1.54 = 30.8 \text{ db}$$

Decibels as Power Level The original use of the decibel was only as a *ratio* of power levels—not as an absolute measure of power. However, one may use the decibel as such an absolute unit by fixing an arbitrary "zero" level, and to indicate any power level by its number of decibels above or below this arbitrary zero level. This is all very good so long as we agree on the zero level.

Any power level may then be converted to decibels by the equation:

$$N_{db} = 10 \log \frac{P_o}{P_{ref}}$$

where *N_{db}* is the desired power level in decibels, *P_o* the output of the amplifier, *P_{ref}* the arbitrary reference level.

The zero level most frequently used (but not always) is 6 milliwatts or 0.006 watts. For this zero level, the equation reduces to

$$N_{db} = 10 \log \frac{P_o}{0.006}$$

Example: An amplifier using a 6F6 tube should be able to deliver an undistorted output of 3 watts. How much is this in decibels?

$$\frac{P_o}{P_{ref}} = \frac{3}{.006} = 500$$

$$10 \times \log 500 = 10 \times 2.70 = 27.0$$

Therefore the power level at the output of the 6F6 is 27.0 decibels. When the power level to be converted is less than 6 milliwatts, the level is noted as negative. Here we must remember all that has been said regarding logarithms of numbers less than unity and the fact that the characteristic is negative but not the mantissa.

A preamplifier for a microphone is feeding 1.5 milliwatts into the line going to the regular speech amplifier. What is this power level expressed in decibels?

$$\begin{aligned} \text{decibels} &= 10 \log \frac{P_o}{0.006} = \\ &= 10 \log \frac{0.0015}{0.006} = 10 \log 0.25 \end{aligned}$$

Log 0.25 = -1.398 (from table). Therefore, 10 × -1.398 = (10 × -1 = -10) + (10 × .398 = 3.98); adding the products algebraically, gives -6.02 db.

The conversion chart reproduced in this chapter will be of use in converting decibels to watts and vice versa.

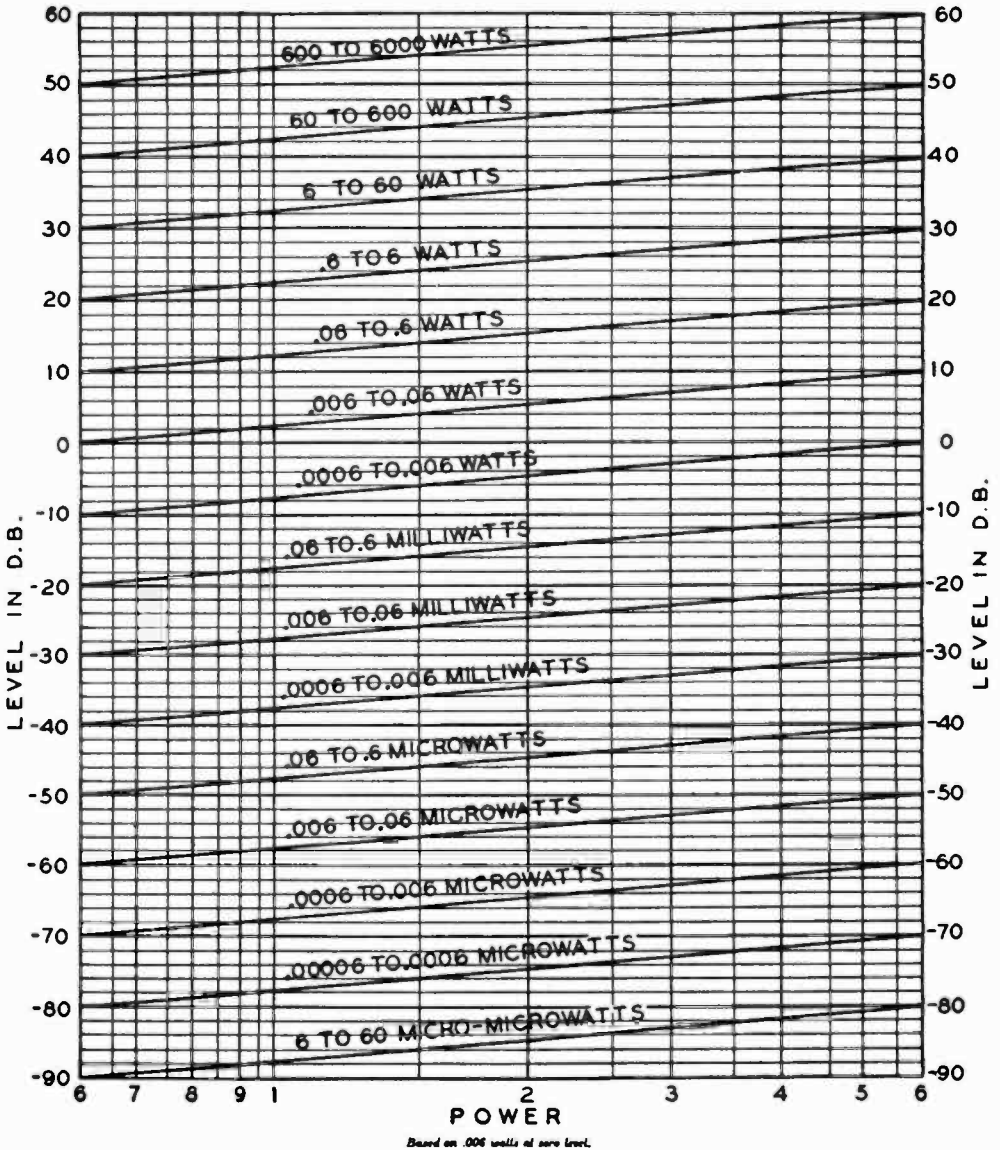

Figure 9.
CONVERSION CHART: POWER TO DECIBELS

Power levels between 6 micromicrowatts and 6000 watts may be referred to corresponding decibel levels between -90 and 60 db, and vice versa, by means of the above chart. Fifteen ranges are provided. Each curve begins at the same point where the preceding one ends, enabling uninterrupted coverage of the wide db and power ranges with condensed chart. For example: the lowermost curve ends at -80 db or 60 micromicrowatts and the next range starts at the same level. Zero db level is taken as 6 milliwatts (.006 watt).

Converting Decibels to Power It is often convenient to be able to convert a decibel value to a power equivalent. The formula used for this operation is

$$P = 0.006 \times \text{antilog} \frac{N_{db}}{10}$$

where P is the desired level in watts and N_{db} the decibels to be converted.

To determine the power level P from a decibel equivalent, simply divide the decibel value by 10; then take the number comprising the antilog and multiply it by 0.006; the product gives the level in watts.

Note: In problems dealing with the conversion of *minus* decibels to power, it often happens that the decibel value $-N_{db}$ is not divisible by 10. When this is the case, the numerator in the factor $-\frac{N_{db}}{10}$ must be made evenly divisible by 10, the negative signs must be observed, and the quotient labeled accordingly.

To make the numerator evenly divisible by 10 proceed as follows: Assume, for example, that $-N_{db}$ is some such value as -38 ; to make this figure evenly divisible by 10, we must add -2 to it, and, since we have added a negative 2 to it, we must also add a positive 2 so as to keep the net result the same.

Our decibel value now stands, $-40 + 2$. Dividing both of these figures by 10, as in the equation above, we have -4 and $+0.2$. Putting the two together we have the logarithm -4.2 with the negative characteristic and the positive mantissa as required.

The following examples will show the technique to be followed in practical problems.

(a) The output of a certain device is rated at -74 db. What is the power equivalent?

Solution:

$$\frac{N_{db}}{10} = \frac{-74}{10} \text{ (not evenly divisible by 10)}$$

Routine:

$$\begin{array}{r} -74 \\ -6 \quad +6 \\ \hline -80 \quad +6 \end{array}$$

$$\frac{N_{db}}{10} = \frac{-80 + 6}{10} = -8.6$$

$$\begin{aligned} \text{antilog } -8.6 &= 0.000\ 000\ 04 \\ .006 \times 0.000\ 000\ 04 &= \\ 0.000\ 000\ 000\ 24 \text{ watt or} & \\ 240 \text{ micro-microwatt} & \end{aligned}$$

(b) This example differs somewhat from that of the foregoing one in that the mantissas are added differently. A low-powered amplifier has an input signal level of -17.3 db. How many milliwatts does this value represent?

Solution:

$$\begin{array}{r} -17.3 \\ -2.7 \quad +2.7 \\ \hline -20 \quad +2.7 \end{array}$$

$$\frac{N_{db}}{10} = \frac{-20 + 2.7}{10} = -2.27$$

$$\text{Antilog } -2.27 = 0.0186$$

$$\begin{aligned} 0.006 \times 0.0186 &= 0.000\ 1116 \text{ watt or} \\ 0.1116 \text{ milliwatt} & \end{aligned}$$

Input voltages: To determine the required input voltage, take the peak voltage necessary to drive the last class A amplifier tube to maximum output, and divide this figure by the total overall voltage gain of the preceding stages.

Computing Specifications: From the preceding explanations the following data can be computed with any degree of accuracy warranted by the circumstances:

- (1) Voltage amplification
- (2) Overall gain in db
- (3) Output signal level in db
- (4) Input signal level in db
- (5) Input signal level in watts
- (6) Input signal voltage

When a power level is available which must be brought up to a new power level, the gain required in the intervening amplifier is equal to the difference between the two levels in decibels. If the required input of an amplifier for full output is -30 decibels and the output from a device to be used is but -45 decibels, the pre-amplifier required should have a gain of the difference, or 15 decibels. Again this is true only if the two amplifiers are properly matched and no losses are introduced due to mismatching.

Push-Pull Amplifiers To double the output of any cascade amplifier, it is only necessary to connect in push-pull the last amplifying stage, and replace the inter-stage and output transformers with push-pull types.

To determine the voltage gain (voltage ratio) of a push-pull amplifier, take the ratio of one *half* of the secondary winding of the push-pull transformer and multiply it by the μ of one of the output tubes in the push-pull stage; the product, *when doubled*, will be the voltage amplification, or step-up.

Other Units and Zero Levels When working with decibels one should not immediately take for granted that the zero level is 6 milliwatts for there are other zero levels in use.

In broadcast stations an entirely new system is now employed. Measurements made in

acoustics are now made with the standard zero level of 10^{-16} watts per square cm.

Microphones are often rated with reference to the following zero level: *one volt at open circuit when the sound pressure is one millibar.* In any case, the rating of the microphone must include the loudness of the sound. It is obvious that this zero level does not lend itself readily for the calculation of required gain in an amplifier.

The VU: So far, the decibel has always referred to a type of signal which can readily be measured, that is, a steady signal of a single frequency. But what would be the power level of a signal which is constantly varying in volume and frequency? The measurement of voltage would depend on the type of instrument employed, whether it is measured with a thermal square law meter or one that shows average values; also, the inertia of the movement will change its indications at the peaks and valleys.

After considerable consultation, the broadcast chains and the Bell System have agreed on the *VU*. The level in *VU* is the level in decibels above *1 milliwatt* zero level and measured with a carefully defined type of instrument across a 600 ohm line. So long as we deal with an unvarying sound, the level in *VU* is equal to decibels above 1 milliwatt; but when the sound level varies, the unit is the *VU* and the special meter must be used. There is then no equivalent in decibels.

The Neper: We might have used the natural logarithm instead of the common logarithm when defining our logarithmic unit of sound. This was done in Europe and the unit obtained is known as the *neper* or *napier*. It is still found in some American literature on filters.

- 1 neper = 8.686 decibels
- 1 decibel = 0.1151 neper

AC Meters With Decibel Scales Many test instruments are now equipped with scales calibrated in decibels which is very handy when making measurements of frequency characteristics and gain. These meters are generally calibrated for connection across a 500 ohm line and for a zero level of 6 milliwatts. When they are connected across another impedance, the reading on the meter is no longer correct for the zero level of 6 milliwatts. A correction factor should be applied consisting in the addition or subtraction of a steady figure to all readings on the meter. This figure is given by the equation:

$$\text{db to be added} = 10 \log \frac{500}{Z}$$

where *Z* is the impedance of the circuit under measurement.

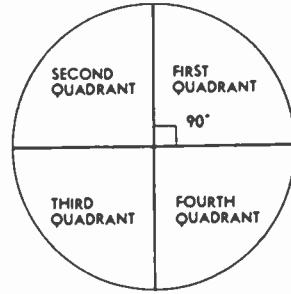

Figure 10.

THE CIRCLE IS DIVIDED INTO FOUR QUADRANTS BY TWO PERPENDICULAR LINES AT RIGHT ANGLES TO EACH OTHER.

The "northeast" quadrant thus formed is known as the first quadrant; the others are numbered consecutively in a counterclockwise direction.

Trigonometry

Definition and Use Trigonometry is the science of mensuration of *triangles*. At first glance triangles may seem to

have little to do with electrical phenomena; however, in a.c. work most currents and voltages follow laws equivalent to those of the various trigonometric relations which we are about to examine briefly. Examples of their application to a.c. work will be given in the section on *Vectors*.

Angles are measured in *degrees* or in *radians*. The circle has been divided into 360 degrees, each degree into 60 minutes, and each minute into 60 seconds. A decimal division of the degree is also in use because it makes calculation easier. Degrees, minutes and seconds are indicated by the following signs: °, ' and '' Example: 6° 5' 23'' means six degrees, five minutes, twenty-three seconds. In the decimal notation we simply write 8.47°, eight and forty-seven hundredths of a degree.

When a circle is divided into four quadrants by two perpendicular lines passing through the center (Figure 10) the angle made by the two lines is 90 degrees, known as a *right angle*. Two right angles, or 180° equals a *straight angle*.

The radian: If we take the radius of a circle and bend it so it can cover a part of the circumference, the arc it covers subtends an angle called a *radian* (Figure 11). Since the diameter of a circle equals 2 times the radius, there are 2π radians in 360°. So we have the following relations:

- 1 radian = 57° 17' 45'' = 57.2958° $\pi = 3.14159$
- 1 degree = 0.01745 radians
- π radians = 180° $\pi/2$ radians = 90°
- $\pi/3$ radians = 60°

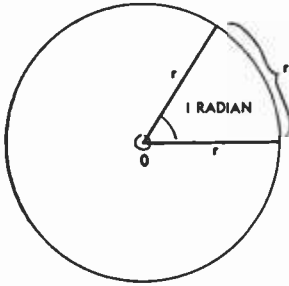

Figure 11.
THE RADIAN.

A radian is an angle whose arc is exactly equal to the length of either side. Note that the angle is constant regardless of the length of the side and the arc so long as they are equal. A radian equals 57.2958°.

In trigonometry we consider an angle generated by two lines, one stationary and the other rotating as if it were hinged at O, Figure 12. Angles can be greater than 180 degrees and even greater than 360 degrees as illustrated in this figure.

Two angles are complements of each other when their sum is 90°, or a right angle. A is the complement of B and B is the complement of A when

$$A = (90^\circ - B)$$

and when

$$B = (90^\circ - A)$$

Two angles are supplements of each other when their sum is equal to a straight angle, or 180°. A is the supplement of B and B is the supplement of A when

$$A = (180^\circ - B)$$

and

$$B = (180^\circ - A)$$

In the angle A, Figure 13A, a line is drawn from P, perpendicular to b. Regardless of the point selected for P, the ratio a/c will always be the same for any given angle, A. So will all the other proportions between a, b, and c remain constant regardless of the position of point P on c. The six possible ratios each are named and defined as follows:

$$\begin{aligned} \text{sine } A &= \frac{a}{c} & \text{cosine } A &= \frac{b}{c} \\ \text{tangent } A &= \frac{a}{b} & \text{cotangent } A &= \frac{b}{a} \\ \text{secant } A &= \frac{c}{b} & \text{cosecant } A &= \frac{c}{a} \end{aligned}$$

Let us take a special angle as an example. For instance, let the angle A be 60 degrees as in Figure 13B. Then the relations between the sides are as in the figure and the six functions become:

$$\begin{aligned} \sin 60^\circ &= \frac{a}{c} = \frac{\frac{1}{2}\sqrt{3}}{1} = \frac{1}{2}\sqrt{3} \\ \cos 60^\circ &= \frac{b}{c} = \frac{\frac{1}{2}}{1} = \frac{1}{2} \\ \tan 60^\circ &= \frac{a}{b} = \frac{\frac{1}{2}\sqrt{3}}{\frac{1}{2}} = \sqrt{3} \\ \cot 60^\circ &= \frac{\frac{1}{2}}{\frac{1}{2}\sqrt{3}} = \frac{1}{\sqrt{3}} = \frac{1}{3}\sqrt{3} \\ \sec 60^\circ &= \frac{c}{b} = \frac{1}{\frac{1}{2}} = 2 \\ \csc 60^\circ &= \frac{c}{a} = \frac{1}{\frac{1}{2}\sqrt{3}} = \frac{2}{3}\sqrt{3} \end{aligned}$$

Another example: Let the angle be 45°, then the relations between the lengths of a, b, and c are as shown in Figure 13C, and the six functions are:

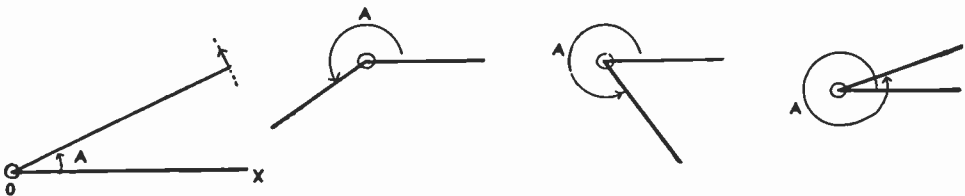

Figure 12.

AN ANGLE IS GENERATED BY TWO LINES, ONE STATIONARY AND THE OTHER ROTATING.

The line OX is stationary; the line with the small arrow at the far end rotates in a counterclockwise direction. At the position illustrated in the lefthandmost section of the drawing it makes an angle, A, which is less than 90° and is therefore in the first quadrant. In the position shown in the second portion of the drawing the angle A has increased to such a value that it now lies in the third quadrant; note that an angle can be greater than 180°. In the third illustration the angle A is in the fourth quadrant. In the fourth position the rotating vector has made more than one complete revolution and is hence in the fifth quadrant; since the fifth quadrant is an exact repetition of the first quadrant. Its values will be the same as in the lefthandmost portion of the illustration.

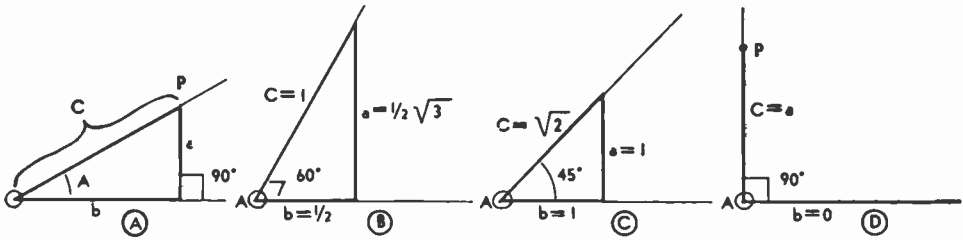

Figure 13.

THE TRIGONOMETRIC FUNCTIONS.

In the right triangle shown in (A) the side opposite the angle A is a, while the adjoining sides are b and c; the trigonometric functions of the angle A are completely defined by the ratios of the sides a, b and c. In (B) are shown the lengths of the sides a and b when angle A is 60° and side c is 1. In (C) angle A is 45°; a and b equal 1, while c equals $\sqrt{2}$. In (D) note that c equals a for a right angle while b equals 0.

$$\sin 45^\circ = \frac{1}{\sqrt{2}} = \frac{1}{2}\sqrt{2}$$

$$\cos 45^\circ = \frac{1}{\sqrt{2}} = \frac{1}{2}\sqrt{2}$$

$$\tan 45^\circ = \frac{1}{1} = 1$$

$$\cot 45^\circ = \frac{1}{1} = 1$$

$$\sec 45^\circ = \frac{\sqrt{2}}{1} = \sqrt{2}$$

$$\operatorname{cosec} 45^\circ = \frac{\sqrt{2}}{1} = \sqrt{2}$$

There are some special difficulties when the angle is zero or 90 degrees. In Figure 13D an angle of 90 degrees is shown; drawing a line perpendicular to b from point P makes it fall on top of c. Therefore in this case a = c and b = 0. The six ratios are now:

$$\sin 90^\circ = \frac{a}{c} = 1 \quad \cos 90^\circ = \frac{b}{c} = \frac{0}{c} = 0$$

$$\tan 90^\circ = \frac{a}{b} = \frac{a}{0} = \infty \quad \cot 90^\circ = \frac{0}{a} = 0$$

$$\sec 90^\circ = \frac{c}{b} = \frac{c}{0} = \infty \quad \operatorname{cosec} 90^\circ = \frac{c}{a} = 1$$

When the angle is zero, a = 0 and b = c. The values are then:

$$\sin 0^\circ = \frac{a}{c} = \frac{0}{c} = 0 \quad \cos 0^\circ = \frac{b}{c} = 1$$

$$\tan 0^\circ = \frac{a}{b} = \frac{0}{b} = 0 \quad \cot 0^\circ = \frac{b}{a} = \frac{b}{0} = \infty$$

$$\sec 0^\circ = \frac{c}{b} = 1 \quad \operatorname{cosec} 0^\circ = \frac{c}{a} = \frac{c}{0} = \infty$$

In general, for every angle, there will be definite values of the six functions. Conversely, when any of the six functions is known, the angle is defined. Tables have been calculated giving the value of the functions for angles.

From the foregoing we can make up a small table of our own (Figure 14), giving values of the functions for some common angles.

Relations Between Functions

It follows from the definitions that

$$\sin A = \frac{1}{\operatorname{cosec} A} \quad \cos A = \frac{1}{\sec A}$$

$$\text{and } \tan A = \frac{1}{\cot A}$$

From the definitions also follows the relation

$$\cos A = \sin (\text{complement of } A) = \sin (90^\circ - A)$$

because in the right triangle of Figure 15, $\cos A = b/c = \sin B$ and $B = 90^\circ - A$ or the complement of A. For the same reason:

$$\cot A = \tan (90^\circ - A)$$

$$\operatorname{csc} A = \sec (90^\circ - A)$$

Relations in Right Triangles

In the right triangle of Figure 15, $\sin A = a/c$ and by transposition

$$a = c \sin A$$

For the same reason we have the following identities:

$$\tan A = a/b \quad a = b \tan A$$

$$\cot A = b/a \quad b = a \cot A$$

In the same triangle we can do the same for functions of the angle B

Angle	Sin	Cos.	Tan	Cot	Sec.	Cosec.
0	0	1	0	∞	1	∞
30°	$\frac{1}{2}$	$\frac{1}{2}\sqrt{3}$	$\frac{1}{3}\sqrt{3}$	$\sqrt{3}$	$\frac{2}{3}\sqrt{3}$	2
45°	$\frac{1}{2}\sqrt{2}$	$\frac{1}{2}\sqrt{2}$	1	1	$\sqrt{2}$	$\sqrt{2}$
60°	$\frac{1}{2}\sqrt{3}$	$\frac{1}{2}$	$\sqrt{3}$	$\frac{1}{3}\sqrt{3}$	2	$\frac{2}{3}\sqrt{3}$
90°	1	0	∞	0	∞	1

Figure 14.

Values of trigonometric functions for common angles in the first quadrant.

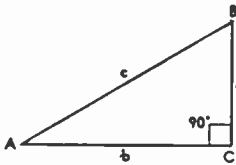

Figure 15.

In this figure the sides *a*, *b*, and *c* are used to define the trigonometric functions of angle *B* as well as angle *A*.

$\sin B = b/c$	$b = c \sin B$
$\cos B = a/c$	$a = c \cos B$
$\tan B = b/a$	$b = a \tan B$
$\cot B = a/b$	$a = b \cot B$

Functions of Angles Greater than 90 Degrees

In angles greater than 90 degrees, the values of *a* and *b* become negative on occasion in accordance with the rules of Cartesian coordinates.

When *b* is measured from 0 towards the left it is considered negative and similarly, when *a* is measured from 0 downwards, it is negative. Referring to Figure 16, an angle in the *second quadrant* (between 90° and 180°) has some of its functions negative:

$\sin A = \frac{a}{c} = \text{pos.}$	$\cos A = \frac{-b}{c} = \text{neg.}$
$\tan A = \frac{a}{-b} = \text{neg.}$	$\cot A = \frac{-b}{a} = \text{neg.}$
$\sec A = \frac{c}{-b} = \text{neg.}$	$\text{cosec } A = \frac{c}{a} = \text{pos.}$

For an angle in the *third quadrant* (180° to 270°), the functions are

$\sin A = \frac{-a}{c} = \text{neg.}$	$\cos A = \frac{-b}{c} = \text{neg.}$
$\tan A = \frac{-a}{-b} = \text{pos.}$	$\cot A = \frac{-b}{-a} = \text{pos.}$

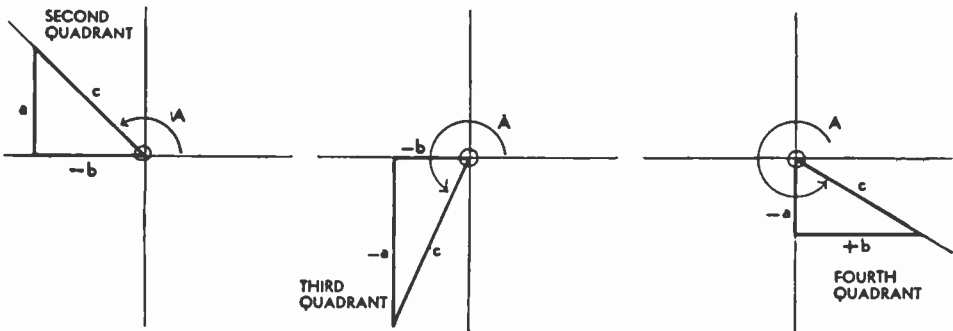

Figure 16.

TRIGONOMETRIC FUNCTIONS IN THE SECOND, THIRD, AND FOURTH QUADRANTS.

The trigonometric functions in these quadrants are similar to first quadrant values, but the signs of the functions vary as listed in the text and in Figure 17.

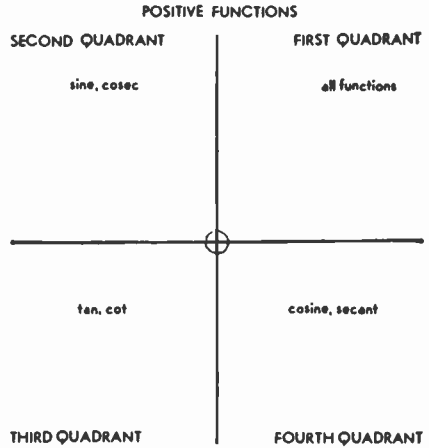

Figure 17.

SIGNS OF THE TRIGONOMETRIC FUNCTIONS.

The functions listed in this diagram are positive; all other functions are negative.

$\sec A = \frac{c}{-b} = \text{neg.}$ $\text{cosec } A = \frac{c}{-a} = \text{neg.}$

And in the fourth quadrant (270° to 360°):

$\sin A = \frac{-a}{c} = \text{neg.}$	$\cos A = \frac{b}{c} = \text{pos.}$
$\tan A = \frac{-a}{b} = \text{neg.}$	$\cot A = \frac{b}{-a} = \text{neg.}$
$\sec A = \frac{c}{b} = \text{pos.}$	$\text{cosec } A = \frac{c}{-a} = \text{neg.}$

Summarizing, the sign of the functions in each quadrant can be seen at a glance from Figure 17, where in each quadrant are written the names of functions which are positive; those not mentioned are negative.

Figure 18.
SINE AND COSINE CURVES.
In (A) we have a sine curve drawn in Cartesian coordinates. This is the usual representation of an alternating current wave without substantial harmonics. In (B) we have a cosine wave; note that it is exactly similar to a sine wave displaced by 90° or $\pi/2$ radians.

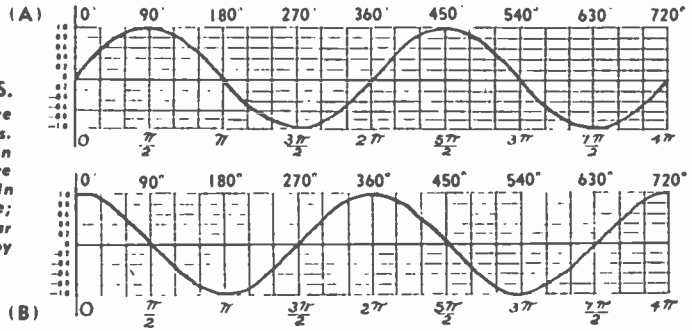

Graphs of Trigonometric Functions

The sine wave. When we have the relation $y = \sin x$, where x is an angle measured in radians or degrees, we can draw a curve of y versus x for all values of the independent variable, and thus get a good conception how the sine varies with the magnitude of the angle. This has been done in Figure 18A. We can learn from this curve the following facts.

1. The sine varies between +1 and -1
2. It is a periodic curve, repeating itself after every multiple of 2π or 360°
3. $\sin x = \sin (180^\circ - x)$ or $\sin (\pi - x)$
4. $\sin x = -\sin (180^\circ + x)$, or $-\sin (\pi + x)$

The cosine wave. Making a curve for the function $y = \cos x$, we obtain a curve similar to that for $y = \sin x$ except that it is displaced by 90° or $\pi/2$ radians with respect to the Y-axis. This curve (Figure 18B) is also periodic but it does not start with zero. We read from the curve:

1. The value of the cosine never goes beyond +1 or -1
2. The curve repeats, after every multiple of 2π radians or 360°

3. $\cos x = -\cos (180^\circ - x)$ or $-\cos (\pi - x)$

4. $\cos x = \cos (360^\circ - x)$ or $\cos (2\pi - x)$

The graph of the tangent is illustrated in Figure 19. This is a discontinuous curve and illustrates well how the tangent increases from zero to infinity when the angle increases from zero to 90° . Then when the angle is further increased, the tangent starts from minus infinity going to zero in the second quadrant, and to infinity again in the third quadrant.

1. The tangent can have any value between $+\infty$ and $-\infty$
2. The curve repeats and the period is π radians or 180° , not 2π radians
3. $\tan x = \tan (180^\circ + x)$ or $\tan (\pi + x)$
4. $\tan x = -\tan (180^\circ - x)$ or $-\tan (\pi - x)$

The graph of the cotangent is the inverse of that of the tangent, see Figure 20. It leads us to the following conclusions:

1. The cotangent can have any value between $+\infty$ and $-\infty$
2. It is a periodic curve, the period being π radians or 180°
3. $\cot x = \cot (180^\circ + x)$ or $\cot (\pi + x)$
4. $\cot x = -\cot (180^\circ - x)$ or $-\cot (\pi - x)$

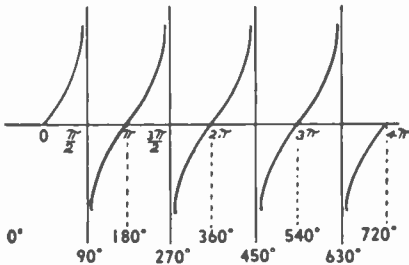

Figure 19.
TANGENT CURVES.

The tangent curve increases from 0 to ∞ with an angular increase of 90° . In the next 180° it increases from $-\infty$ to $+\infty$.

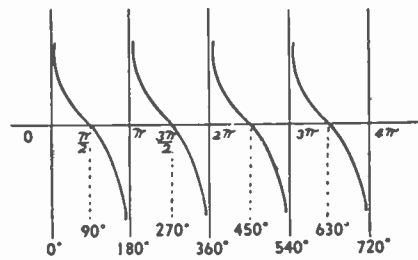

Figure 20.
COTANGENT CURVES.

Cotangent curves are the inverse of the tangent curves. They vary from $+\infty$ to $-\infty$ in each pair of quadrants.

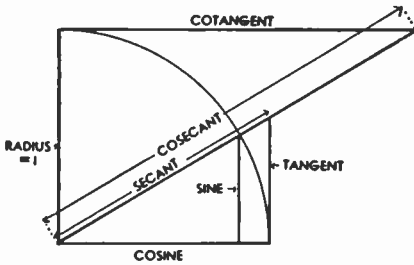

Figure 21.

ANOTHER REPRESENTATION OF TRIGONOMETRIC FUNCTIONS.

If the radius of a circle is considered as the unit of measurement, then the lengths of the various lines shown in this diagram are numerically equal to the functions marked adjacent to them.

The graphs of the secant and cosecant are of lesser importance and will not be shown here. They are the inverse, respectively, of the cosine and the sine, and therefore they vary from +1 to infinity and from -1 to -infinity.

Perhaps another useful way of visualizing the values of the functions is by considering Figure 21. If the radius of the circle is the unit of measurement then the lengths of the lines are equal to the functions marked on them.

Trigonometric Tables There are two kinds of trigonometric tables. The first type gives the functions of the angles, the second the logarithms of the functions. The first kind is also known as the table of natural trigonometric functions.

These tables give the functions of all angles between 0 and 45°. This is all that is necessary for the function of an angle between 45° and 90° can always be written as the co-function of an angle below 45°. Example: If we had to find the sine of 48°, we might write

$$\sin 48^\circ = \cos (90^\circ - 48^\circ) = \cos 42^\circ$$

Tables of the logarithms of trigonometric functions give the common logarithms (\log_{10}) of these functions. Since many of these logarithms have negative characteristics, one should add -10 to all logarithms in the table which have a characteristic of 6 or higher. For instance, the $\log \sin 24^\circ = 9.60931 - 10$. $\log \tan 1^\circ = 8.24192 - 10$ but $\log \cot 1^\circ = 1.75808$. When the characteristic shown is less than 6, it is supposed to be positive and one should not add -10.

Vectors

A scalar quantity has magnitude only; a vector quantity has both magnitude and direction. When we speak of a speed of 50 miles per hour, we are using a scalar quantity, but when we say the wind is Northeast and has a



Figure 22.

Vectors may be added as shown in these sketches. In each case the long vector represents the vector sum of the smaller vectors. For many engineering applications sufficient accuracy can be obtained by this method which avoids long and laborious calculations.

velocity of 50 miles per hour, we speak of a vector quantity.

Vectors, representing forces, speeds, displacements, etc., are represented by arrows. They can be added graphically by well known methods illustrated in Figure 22. We can make the parallelogram of forces or we can simply draw a triangle. The addition of many vectors can be accomplished graphically as in the same figure.

In order that we may define vectors algebraically and add, subtract, multiply, or divide them, we must have a logical notation system that lends itself to these operations. For this purpose vectors can be defined by coordinate systems. Both the Cartesian and the polar coordinates are in use.

Vectors Defined by Cartesian Coordinates

Since we have seen how the sum of two vectors is obtained, it follows from Figure 23, that the vector \hat{Z}

equals the sum of the two vectors \hat{x} and \hat{y} . In fact, any vector can be resolved into vectors along the X- and Y-axis. For convenience in working with these quantities we need to dis-

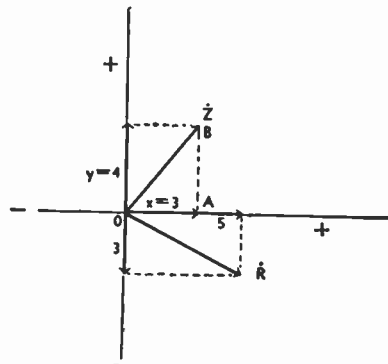

Figure 23.

RESOLUTION OF VECTORS.

Any vector such as \hat{Z} may be resolved into two vectors, \hat{x} and \hat{y} , along the X- and Y-axes. If vectors are to be added, their respective \hat{x} and \hat{y} components may be added to find the \hat{x} and \hat{y} components of the resultant vector.

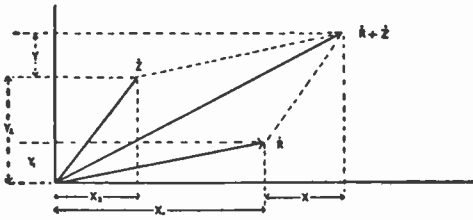

Figure 24.
ADDITION OR SUBTRACTION OF VECTORS.

Vectors may be added or subtracted by adding or subtracting their *x* or *y* components separately.

tinguish between the *X*- and *Y*-component, and so it has been agreed that the *Y*-component alone shall be marked with the letter *j*. Example (Figure 23):

$$\dot{Z} = 3 + 4j$$

Note again that the sign of components along the *X*-axis is positive when measured from 0 to the right and negative when measured from 0 towards the left. Also, the component along the *Y*-axis is positive when measured from 0 upwards, and negative when measured from 0 downwards. So the vector, \dot{R} , is described as

$$\dot{R} = 5 - 3j$$

Vector quantities are usually indicated by some special typography, especially by using a point over the letter indicating the vector, as \dot{R} .

Absolute Value of a Vector The absolute or scalar value of vectors such as \dot{Z} or \dot{R} in Figure 23 is easily found by the theorem of Pythagoras, which states that in any right-angled triangle the square of the side opposite the right angle is equal to the sum of the squares of the sides adjoining the right angle. In Figure 23, *OAB* is a right-angled triangle; therefore, the square of *OB* (or *Z*) is equal to the square of *OA* (or *x*) plus the square of *AB* (or *y*). Thus the absolute values of *Z* and *R* may be determined as follows:

$$|Z| = \sqrt{x^2 + y^2}$$

$$|Z| = \sqrt{3^2 + 4^2} = 5$$

$$|R| = \sqrt{5^2 + 3^2} = \sqrt{34} = 5.83$$

The vertical lines indicate that the absolute or scalar value is meant without regard to sign or direction.

Addition of Vectors An examination of Figure 24 will show that the two vectors

$$\dot{R} = x_1 + jy_1$$

$$\dot{Z} = x_2 + jy_2$$

can be added, if we add the *X*-components and the *Y*-components separately.

$$\dot{R} + \dot{Z} = x_1 + x_2 + j(y_1 + y_2)$$

For the same reason we can carry out subtraction by subtracting the horizontal components and subtracting the vertical components

$$\dot{R} - \dot{Z} = x_1 - x_2 + j(y_1 - y_2)$$

Let us consider the operator *j*. If we have a vector *a* along the *X*-axis and add a *j* in front of it (multiplying by *j*) the result is that the direction of the vector is rotated forward 90 degrees. If we do this twice (multiplying by j^2) the vector is rotated forward by 180 degrees and now has the value $-a$. Therefore multiplying by j^2 is equivalent to multiplying by -1 . Then

$$j^2 = -1 \text{ and } j = \sqrt{-1}$$

This is the imaginary number discussed before under algebra. In electrical engineering the letter *j* is used rather than *i*, because *i* is already known as the symbol for current.

Multiplying Vectors When two vectors are to be multiplied we can perform the operation just as in algebra, remembering that $j^2 = -1$.

$$\begin{aligned} \dot{R}\dot{Z} &= (x_1 + jy_1)(x_2 + jy_2) \\ &= x_1x_2 + jx_1y_2 + jx_2y_1 + j^2y_1y_2 \\ &= x_1x_2 - y_1y_2 + j(x_1y_2 + x_2y_1) \end{aligned}$$

Division has to be carried out so as to remove the *j*-term from the denominator. This can be done by multiplying both denominator and numerator by a quantity which will eliminate *j* from the denominator. Example:

$$\begin{aligned} \frac{\dot{R}}{\dot{Z}} &= \frac{x_1 + jy_1}{x_2 + jy_2} = \frac{(x_1 + jy_1)(x_2 - jy_2)}{(x_2 + jy_2)(x_2 - jy_2)} \\ &= \frac{x_1x_2 + y_1y_2 + j(x_2y_1 - x_1y_2)}{x_2^2 + y_2^2} \end{aligned}$$

Polar Coordinates A vector can also be defined in polar coordinates by its magnitude and its vectorial angle with an arbitrary reference axis. In Figure 25

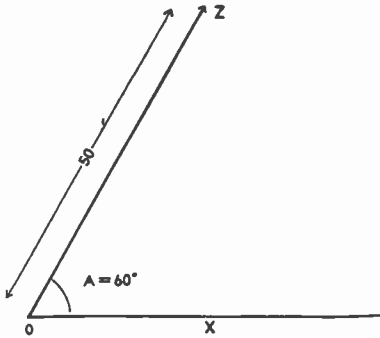

Figure 25.

IN THIS FIGURE A VECTOR HAS BEEN REPRESENTED IN POLAR INSTEAD OF CARTESIAN COORDINATES.

In polar coordinates a vector is defined by a magnitude and an angle, called the vectorial angle, instead of by two magnitudes as in Cartesian coordinates.

the vector \dot{Z} has a magnitude 50 and a vectorial angle of 60 degrees. This will then be written

$$\dot{Z} = 50 \angle 60^\circ$$

A vector $a + jb$ can be transformed into polar notation very simply (see Figure 26)

$$\dot{Z} = a + jb = \sqrt{a^2 + b^2} \angle \tan^{-1} \frac{b}{a}$$

In this connection \tan^{-1} means the angle of which the tangent is. Sometimes the notation $\text{arc tan } b/a$ is used. Both have the same meaning.

A polar notation of a vector can be transformed into a Cartesian coordinate notation in the following manner (Figure 27)

$$\dot{Z} = p \angle A = p \cos A + jp \sin A$$

A sinusoidally alternating voltage or current is symbolically represented by a rotating vector, having a magnitude equal to the peak voltage or current and rotating with an angular velocity of $2\pi f$ radians per second or as many revolutions per second as there are cycles per second.

The instantaneous voltage, e , is always equal to the sine of the vectorial angle of this rotating vector, multiplied by its magnitude.

$$e = E \sin 2\pi ft$$

The alternating voltage therefore varies with time as the sine varies with the angle. If we plot time horizontally and instantaneous voltage vertically we will get a curve like those in Figure 18.

In alternating current circuits, the current

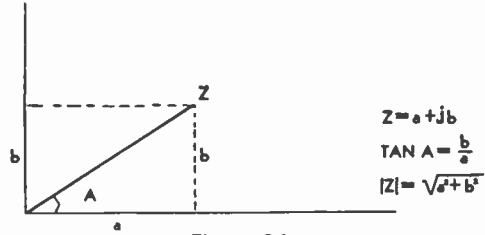

Figure 26.

Vectors can be transformed from Cartesian into polar notation as shown in this figure.

which flows due to the alternating voltage is not necessarily in step with it. The rotating current vector may be ahead or behind the voltage vector, having a phase difference with it. For convenience we draw these vectors as if they were standing still, so that we can indicate the difference in phase or the phase angle. In Figure 28 the current lags behind the voltage by the angle θ , or we might say that the voltage leads the current by the angle θ .

Vector diagrams show the phase relations between two or more vectors (voltages and currents) in a circuit. They may be added and subtracted as described; one may add a voltage vector to another voltage vector or a current vector to a current vector but not a current vector to a voltage vector (for the same reason that one cannot add a force to a speed). Figure 28 illustrates the relations in the simple series circuit of a coil and resistor. We know that the current passing through coil and resistor must be the same and in the same phase, so we draw this current I along the X-axis. We know also that the voltage drop IR across the resistor is in phase with the current, so the vector IR representing the voltage drop is also along the X-axis.

The voltage across the coil is 90 degrees ahead of the current through it; IX must therefore be drawn along the Y-axis. \dot{E} the applied voltage must be equal to the vectorial sum of the two voltage drops, IR and IX , and we have so constructed it in the drawing. Now expressing the same in algebraic notation, we have

$$\dot{E} = IR + jIX$$

$$I\dot{Z} = IR + jIX$$

Dividing by I

$$\dot{Z} = R + jX$$

Due to the fact that a reactance rotates the voltage vector ahead or behind the current vector by 90 degrees, we must mark it with a j in vector notation. Inductive reactance will have a plus sign because it shifts the voltage vector forwards; a capacitive reactance is neg-

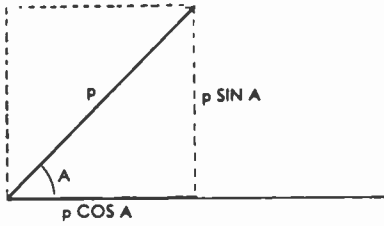

Figure 27.

Vectors can be transformed from polar into Cartesian notation as shown in this figure.

ative because the voltage will lag behind the current. Therefore:

$$X_L = +j 2\pi fL$$

$$X_C = -j \frac{1}{2\pi fC}$$

In Figure 28 the angle θ is known as the phase angle between E and I . When calculating power, only the real components count. The power in the circuit is then

$$P = I (IR)$$

$$\text{but } IR = E \cos \theta$$

$$\therefore P = EI \cos \theta$$

This $\cos \theta$ is known as the power factor of the circuit. In many circuits we strive to keep the angle θ as small as possible, making $\cos \theta$ as near to unity as possible. In tuned circuits, we use reactances which should have as low a power factor as possible. The merit of a coil or condenser, its Q , is defined by the tangent of this phase angle:

$$Q = \tan \theta = X/R$$

For an efficient coil or condenser, Q should be as large as possible; the phase-angle should then be as close to 90 degrees as possible, making the power factor nearly zero. Q is almost but not quite the inverse of $\cos \theta$. Note that in Figure 29

$$Q = X/R \quad \text{and} \quad \cos \theta = R/Z$$

When Q is more than 5, the power factor is less than 20%; we can then safely say $Q = 1/\cos \theta$ with a maximum error of about 2½ percent, for in the worst case, when $\cos \theta = 0.2$, Q will equal $\tan \theta = 4.89$. For higher values of Q , the error becomes less.

Note that from Figure 29 can be seen the simple relation:

$$\dot{Z} = R + jX_L$$

$$|Z| = \sqrt{R^2 + X_L^2}$$

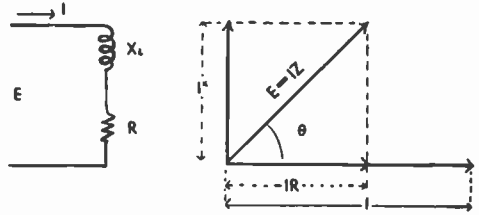

Figure 28.

VECTOR REPRESENTATION OF A SIMPLE SERIES CIRCUIT.

The righthand portion of the illustration shows the vectors representing the voltage drops in the coil and resistance illustrated at the left. Note that the voltage drop across the coil X_L leads that across the resistance by 90°.

Graphical Representation

Formulas and physical laws are often presented in graphical form; this gives us a "bird's eye view" of various possible conditions due to the variations of the quantities involved. In some cases graphs permit us to solve equations with greater ease than ordinary algebra.

Coordinate Systems All of us have used coordinate systems without realizing it. For instance, in modern cities we have numbered streets and numbered avenues. By this means we can define the location of any spot in the city if the nearest street crossings are named. This is nothing but an application of Cartesian coordinates.

In the Cartesian coordinate system (named after Descartes), we define the location of any point in a plane by giving its distance from each of two perpendicular lines or axes. Figure 30 illustrates this idea. The vertical axis is called the Y-axis, the horizontal axis is the X-axis. The intersection of these two axes is called the origin, O. The location of a point, P, (Figure 30) is defined by measuring the respective distances, x and y along the X-axis and the Y-axis. In this example the distance along the X-axis is 2 units and along the Y-axis is 3 units. Thus we define the point as

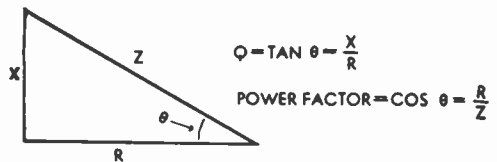

Figure 29.

The figure of merit of a coil and its reactance is represented by the ratio of the inductive reactance to the resistance, which as shown in this diagram is equal to $\frac{X_L}{R}$, which equals $\tan \theta$. For large values of θ (the phase angle) this is approximately equal to the reciprocal of the $\cos \theta$.

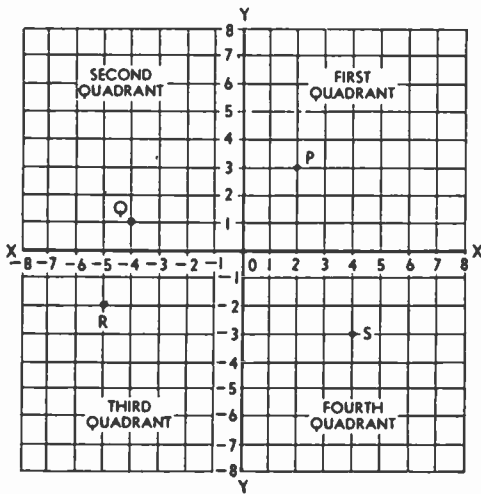

Figure 30.
CARTESIAN COORDINATES.

The location of any point can be defined by its distance from the X and Y axes.

P 2, 3 or we might say $x = 2$ and $y = 3$. The measurement x is called the *abscissa* of the point and the distance y is called its *ordinate*. It is arbitrarily agreed that distances measured from 0 to the right along the X-axis shall be reckoned positive and to the left negative. Distances measured along the Y-axis are positive when measured upwards from 0 and negative when measured downwards from 0. This is illustrated in Figure 30. The two axes divide the plane area into four parts called quadrants. These four quadrants are numbered as shown in the figure.

It follows from the foregoing statements, that points lying within the first quadrant have both x and y positive, as is the case with the point P. A point in the second quadrant has a negative abscissa, x , and a positive ordinate, y . This is illustrated by the point Q, which has the coordinates $x = -4$ and $y = +1$. Points in the third quadrant have both x and y negative. $x = -5$ and $y = -2$ illustrates such a point, R. The point S, in the fourth quadrant has a negative ordinate, y and a positive abscissa or x .

In practical applications we might draw only as much of this plane as needed to illustrate our equation and therefore, the scales along the X-axis and Y-axis might not start with zero and may show only that part of the scale which interests us.

Representation of Functions In the equation:

$$f = \frac{300,000}{\lambda}$$

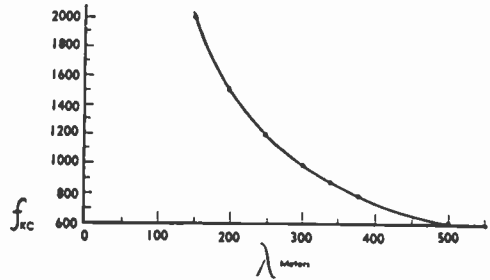

Figure 31.
REPRESENTATION OF A SIMPLE FUNCTION IN CARTESIAN COORDINATES.

In this chart of the function $f_{kc} = \frac{300,000}{\lambda_{meters}}$ distances along the X axis represent wave-length in meters, while those along the Y axis represent frequency in kilocycles. A curve such as this helps to find values between those calculated with sufficient accuracy for most purposes.

f is said to be a function of λ . For every value of f there is a definite value of λ . A variable is said to be a function of another variable when for every possible value of the latter, or *independent* variable, there is a definite value of the first or *dependent* variable. For instance, if $y = 5x^2$, y is a function of x and x is called the independent variable. When $a = 3b^3 + 5b^2 - 25b + 6$ then a is a function of b .

A function can be illustrated in our coordinate system as follows. Let us take the equation for frequency versus wavelength as an example. Given different values to the independent variable find the corresponding values of the dependent variable. Then plot the *points* represented by the different sets of two values.

f_{kc}	λ_{meters}
600	500
800	375
1000	300
1200	250
1400	214
1600	187
1800	167
2000	150

Plotting these points in Figure 31 and drawing a smooth curve through them gives us the *curve* or *graph* of the equation. This curve will help us find values of f for other values of λ (those in between the points calculated) and so a curve of an often-used equation may serve better than a table which always has gaps.

When using the coordinate system described so far and when measuring linearly along both axes, there are some definite rules regarding

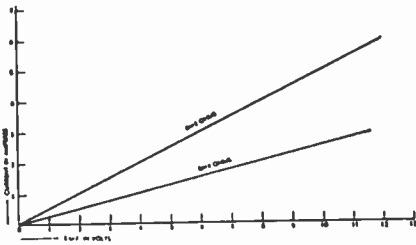

Figure 32.

Only two points are needed to define functions which result in a straight line as shown in this diagram representing Ohm's Law.

the kind of curve we get for any type of equation. In fact, an expert can draw the curve with but a very few plotted points since the equation has told him what kind of curve to expect.

First, when the equation can be reduced to the form $y = mx + b$, where x and y are the variables, it is known as a *linear* or *first degree* function and the curve becomes a straight line. (Mathematicians still speak of a "curve" when it has become a straight line.)

When the equation is of the second degree, that is, when it contains terms like x^2 or y^2 or xy , the graph belongs to a group of curves, called *conic sections*. These include the circle, the ellipse, the parabola and the hyperbola. In the example given above, our equation is of the form

$$xy = c, \quad c \text{ being equal to } 300,000$$

which is a second degree equation and in this case, the graph is a hyperbola.

This type of curve does not lend itself readily for the purpose of calculation except near the middle, because at the ends a very large change in λ represents a small change in f and vice versa. Before discussing what can be done about this let us look at some other types of curves.

Suppose we have a resistance of 2 ohms and we plot the function represented by Ohm's Law: $E = 2I$. Measuring E along the X-axis and amperes along the Y-axis, we plot the necessary points. Since this is a first degree equation, of the form $y = mx + b$ (for $E = y$, $m = 2$ and $I = x$ and $b = 0$) it will be a straight line so we need only two points to plot it.

	$\frac{I}{E}$				
(line passes through origin)	<table border="0" style="margin-left: auto; margin-right: auto;"> <tr> <td style="padding-right: 10px;">0</td> <td style="padding-right: 10px;">0</td> </tr> <tr> <td style="padding-right: 10px;">5</td> <td style="padding-right: 10px;">10</td> </tr> </table>	0	0	5	10
0	0				
5	10				

The line is shown in Figure 32. It is seen to be a straight line passing through the origin.

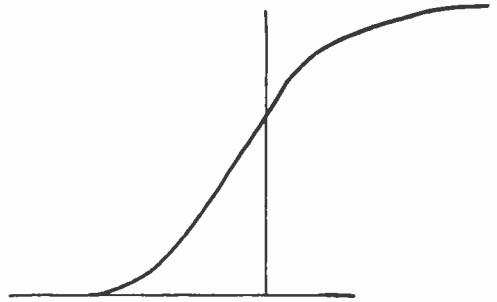

Figure 33.

**A TYPICAL GRID - VOLTAGE
PLATE-CURRENT CHARACTER-
ISTIC CURVE.**

The equation represented by such a curve is so complicated that we do not use it. Data for such a curve is obtained experimentally, and intermediate values can be found with sufficient accuracy from the curve.

If the resistance were 4 ohms, we should get the equation $E = 4I$ and this also represents a line which we can plot in the same figure. As we see, this line also passes through the origin but has a different slope. In this illustration the slope defines the resistance and we could make a protractor which would convert the angle into ohms. This fact may seem inconsequential now, but use of this is made in the drawing of loadlines on tube curves.

Figure 33 shows a typical, grid-voltage, plate-current static characteristic of a triode. The equation represented by this curve is rather complicated so that we prefer to deal with the curve. Note that this curve extends through the first and second quadrant.

Families of curves. It has been explained that curves in a plane can be made to illustrate the relation between *two* variables when one of them varies independently. However, what are we going to do when there are *three* variables and *two* of them vary independently. It is possible to use three dimensions and three axes but this is not conveniently done. Instead of this we may use a *family of curves*. We have already illustrated this partly with Ohm's Law. If we wish to make a chart which will show the current through *any* resistance with *any* voltage applied across it, we must take the equation $E = IR$, having three variables.

We can now draw one line representing a resistance of 1 ohm, another line representing 2 ohms, another representing 3 ohms, etc., or as many as we wish and the size of our paper will allow. The whole set of lines is then applicable to any case of Ohm's Law falling within the range of the chart. If any two of the three quantities are given, the third can be found.

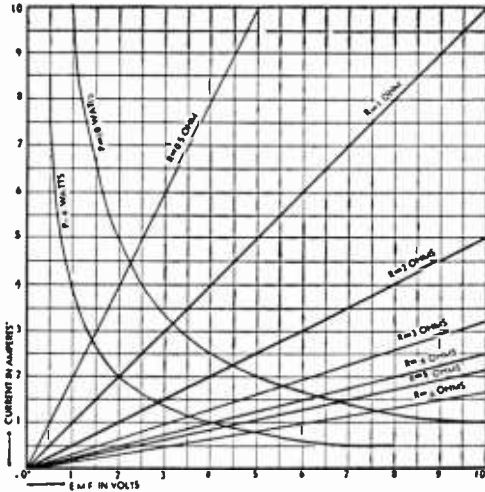

Figure 34.

A FAMILY OF CURVES.

An equation such as Ohm's Law has three variables, but can be represented in Cartesian coordinates by a family of curves such as shown here. If any two quantities are given, the third can be found. Any point in the chart represents a definite value each of E , I , and R , which will satisfy the equation of Ohm's Law. Values of R not situated on an R line can be found by interpolation.

Figure 34 shows such a family of curves to solve Ohm's Law. Any point in the chart represents a definite value each of E , I , and R which will satisfy the equation. The value of R represented by a point that is not situated on an R line can be found by interpolation.

It is even possible to draw on the same chart a second family of curves, representing a fourth variable. But this is not always possible, for among the four variables there should be no more than two independent variables. In our example such a set of lines could represent power in watts; we have drawn only two of these but there could of course be as many as desired. A single point in the plane now indicates the four values of E , I , R , and P which belong together and the knowledge of any two of them will give us the other two by reference to the chart.

Another example of a family of curves is the dynamic transfer characteristic or plate family of a tube. Such a chart consists of several curves showing the relation between plate voltage, plate current, and grid bias of a tube. Since we have again three variables, we must show several curves, each curve for a fixed value of one of the variables. It is customary to plot plate voltage along the X-axis, plate current along the Y-axis, and to make different curves for various values of grid bias. Such a

AVERAGE PLATE CHARACTERISTICS
 $E_g = 6.3$ v.

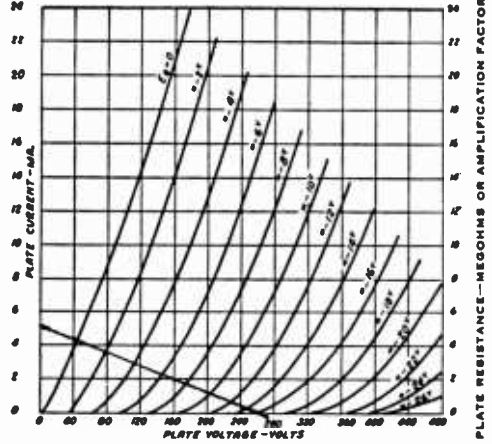

Figure 35.

"PLATE" CURVES FOR A TYPICAL VACUUM TUBE.

In such curves we have three variables, plate voltage, plate current, and grid bias. Each point on a grid bias line corresponds to the plate voltage and plate current represented by its position with respect to the X and Y axes. Those for other values of grid bias may be found by interpolation. The loadline shown in the lower left portion of the chart is explained in the text.

set of curves is illustrated in Figure 35. Each point in the plane is defined by three values, which belong together, plate voltage, plate current, and grid voltage.

Now consider the diagram of a resistance-coupled amplifier in Figure 36. Starting with the B-supply voltage, we know that whatever plate current flows must pass through the resistor and will conform to Ohm's Law. The voltage drop across the resistor is subtracted from the plate supply voltage and the remainder is the actual voltage at the plate, the kind that is plotted along the X-axis in Figure 35. We can now plot on the plate family of the

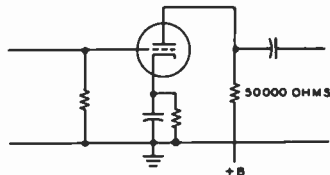

Figure 36.

PARTIAL DIAGRAM OF A RESISTANCE COUPLED AMPLIFIER.

The portion of the supply voltage wasted across the 50,000-ohm resistor is represented in Figure 35 as the loadline.

tube the *loadline*, that is the line showing which part of the plate supply voltage is across the resistor and which part across the tube for any value of plate current. In our example, let us suppose the plate resistor is 50,000 ohms. Then, if the plate current were zero, the voltage drop across the resistor would be zero and the full plate supply voltage is across the tube. Our first point of the loadline is $E = 250, I = 0$. Next, suppose, the plate current were 1 ma., then the voltage drop across the resistor would be 50 volts, which would leave for the tube 200 volts. The second point of the loadline is then $E = 200, I = 1$. We can continue like this but it is unnecessary for we shall find that it is a straight line and two points are sufficient to determine it.

This loadline shows at a glance what happens when the grid-bias is changed. Although there are many possible combinations of plate voltage, plate current, and grid bias, we are now restricted to points along this line as long as the 50,000 ohm plate resistor is in use. This line therefore shows the voltage drop across the tube as well as the voltage drop across the load for every value of grid bias. Therefore, if we know how much the grid bias varies, we can calculate the amount of variation in the plate voltage and plate current, the amplification, the power output, and the distortion.

Logarithmic Scales Sometimes it is convenient to measure along the axes the *logarithms* of our variable quantities. Instead of actually calculating the logarithm, special paper is available with logarithmic scales, that is, the distances measured along the axes are proportional to the logarithms of the numbers marked on them rather than to the numbers themselves.

There is semi-logarithmic paper, having logarithmic scales along one axis only, the other scale being linear. We also have full logarithmic paper where both axes carry logarithmic scales. Many curves are greatly simplified and some become straight lines when plotted on this paper.

As an example let us take the wavelength-frequency relation, charted before on straight cross-section paper.

$$f = \frac{300,000}{\lambda}$$

Taking logarithms:

$$\log f = \log 300,000 - \log \lambda$$

If we plot $\log f$ along the Y-axis and $\log \lambda$ along the X-axis, the curve becomes a straight line. Figure 37 illustrates this graph on full logarithmic paper. The graph may be read with the same accuracy at any point in con-

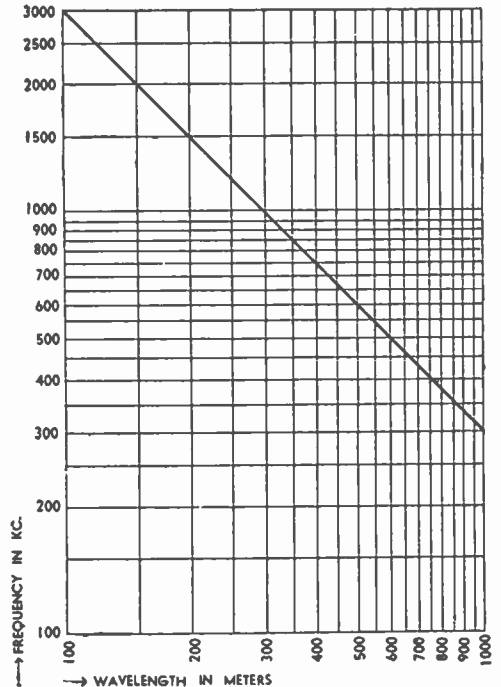

Figure 37.
A LOGARITHMIC CURVE.

Many functions become greatly simplified and some become straight lines when plotted to logarithmic scales such as shown in this diagram. Here the frequency versus wavelength curve of Figure 31 has been replotted to conform with logarithmic axes. Note that it is only necessary to calculate two points in order to determine the "curve" since this type of function results in a straight line.

trast to the graph made with linear coordinates.

This last fact is a great advantage of logarithmic scales in general. It should be clear that if we have a linear scale with 100 small divisions numbered from 1 to 100, and if we are able to read to one tenth of a division, the possible error we can make near 100, way up the scale, is only 1/10th of a percent. But near the beginning of the scale, near 1, one tenth of a division amounts to 10 percent of 1 and we are making a 10 percent error.

In any logarithmic scale, our possible error in measurement or reading might be, say 1/32 of an inch which represents a fixed amount of the log depending on the scale used. The net result of adding to the logarithm a fixed quantity, as 0.01, is that the anti-logarithm is multiplied by 1.025, or the error is 2½%. No matter at what part of the scale the 0.01 is added, the error is always 2½%.

An example of the advantage due to the use

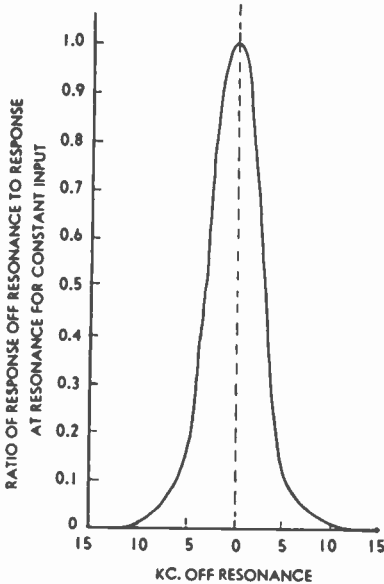

Figure 38.

A RECEIVER RESONANCE CURVE.

This curve represents the output of a receiver versus frequency when plotted to linear coordinates.

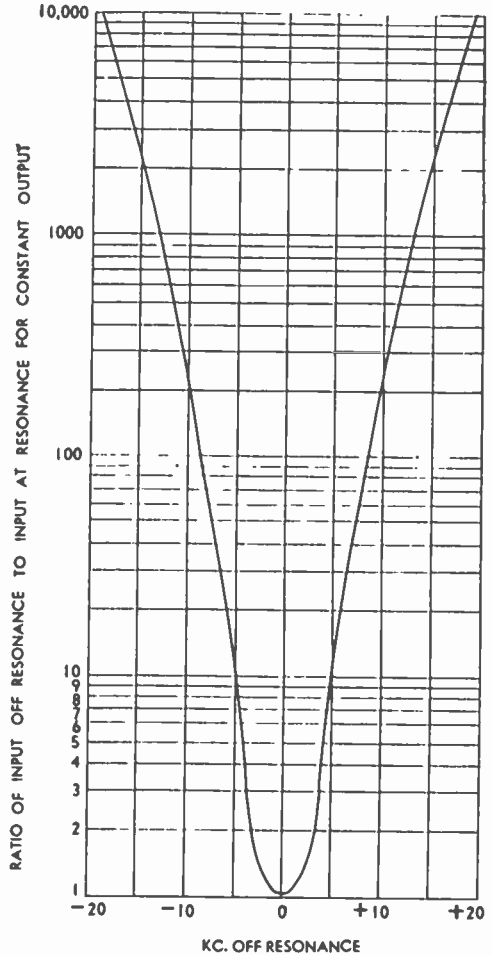

Figure 39.

A RECEIVER SELECTIVITY CURVE.

This curve represents the selectivity of a receiver plotted to logarithmic coordinates for the output, but linear coordinates for frequency. The reason that this curve appears inverted from that of Figure 38 is explained in the text.

of semi-logarithmic paper is shown in Figures 38 and 39. A resonance curve, when plotted on linear coordinate paper will look like the curve in Figure 38. Here we have plotted the output of a receiver against frequency while the applied voltage is kept constant. It is the kind of curve a "wobbulator" will show. The curve does not give enough information in this form for one might think that a signal 10 kc. off resonance would not cause any current at all and is tuned out. However, we frequently have off resonance signals which are 1000 times as strong as the desired signal and one cannot read on the graph of Figure 38 how much any signal is attenuated if it is reduced more than about 20 times.

In comparison look at the curve of Figure 39. Here the response (the current) is plotted in logarithmic proportion, which allows us to plot clearly how far off resonance a signal has to be to be reduced 100, 1,000, or even 10,000 times.

Note that this curve is now "upside down"; it is therefore called a *selectivity* curve. The reason that it appears upside down is that the method of measurement is different. In a selectivity curve we plot the increase in signal voltage necessary to cause a standard output off resonance. It is also possible to plot this increase along the Y-axis in decibels; the curve then looks the same although linear paper can

be used because now our unit is logarithmic.

An example of full logarithmic paper being used for families of curves is shown in the reactance charts of Figures 40 and 41.

Nomograms or Alignment Charts

An alignment chart consists of three or more sets of scales which have been so laid out that to solve the formula for which the chart was made, we have but to lay a straight edge along the two given values on any two of the scales, to find the third and unknown value on the third scale. In its sim-

Figure 40.
REACTANCE-FREQUENCY CHART FOR AUDIO FREQUENCIES

See text for applications and instructions for use.

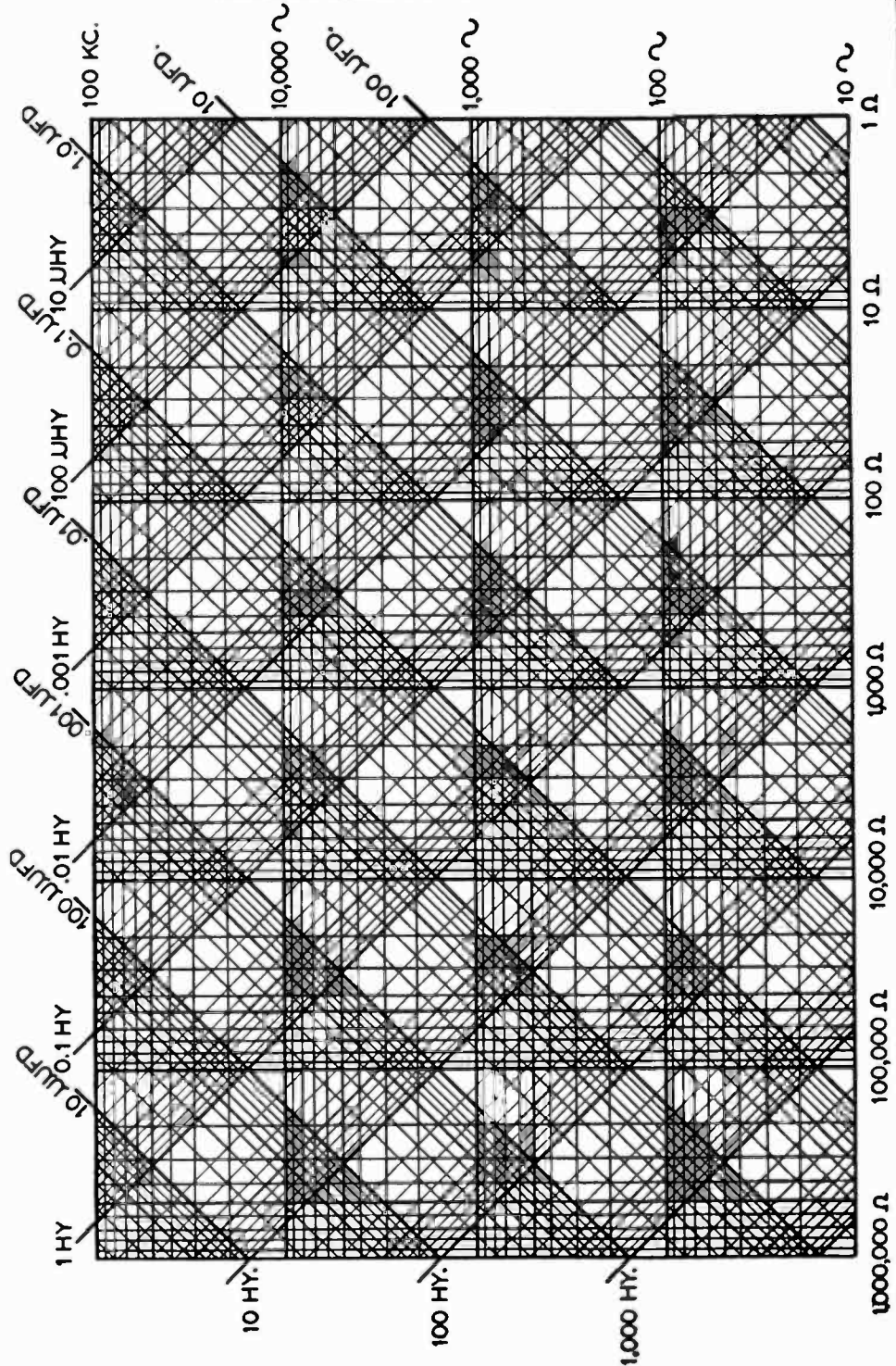

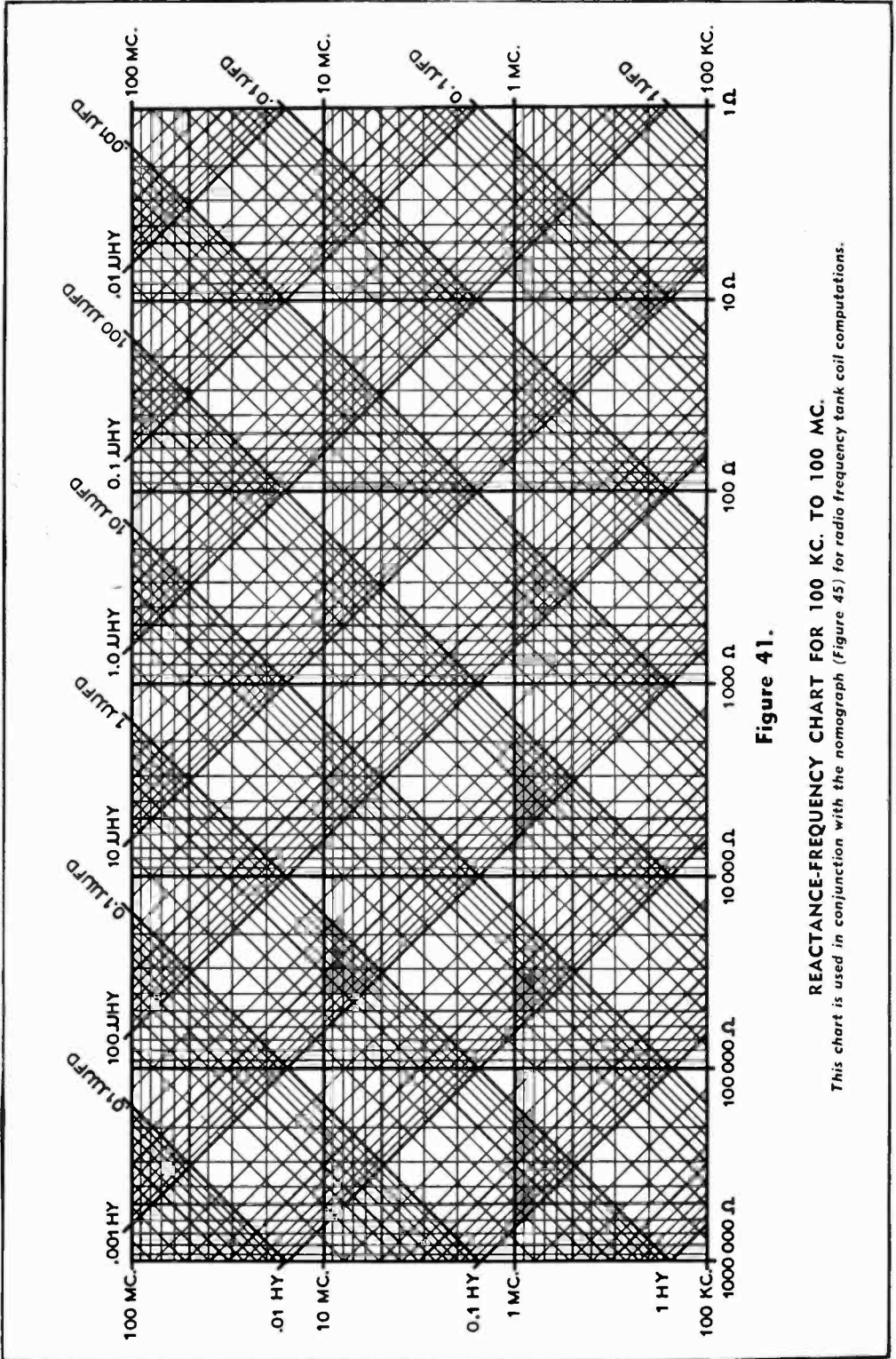

Figure 41.

REACTANCE-FREQUENCY CHART FOR 100 KC. TO 100 MC.
 This chart is used in conjunction with the nomograph (Figure 45) for radio frequency tank coil computations.

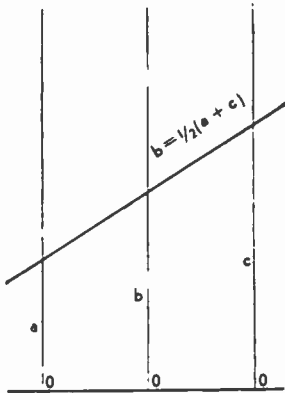

Figure 42.
THE SIMPLEST FORM OF NOMOGRAM.

plest form, it is somewhat like the lines in Figure 42. If the lines a , b , and c are parallel and equidistant, we know from ordinary geometry, that $b = \frac{1}{2}(a + c)$. Therefore, if we draw a scale of the same units on all three lines, starting with zero at the bottom, we know that by laying a straight-edge across the chart at any place, it will connect values of a , b , and c , which satisfy the above equation. When any two quantities are known, the third can be found.

If, in the same configuration we used logarithmic scales instead of linear scales, the relation of the quantities would become

$$\log b = \frac{1}{2}(\log a + \log c) \text{ or } b = \sqrt{ac}$$

By using different kinds of scales, different units, and different spacings between the scales, charts can be made to solve many kinds of equations.

If there are more than three variables it is generally necessary to make a double chart, that is, to make the result from the first chart serve as the given quantity of the second one. Such an example is the chart for the design of coils illustrated in Figure 45. This nomogram is used to convert the inductance in microhenries to physical dimensions of the coil and vice versa. A pin and a straight edge are required. The method is shown under "R. F. Tank Circuit Calculations" later in this chapter.

Polar Coordinates Instead of the Cartesian coordinate system there is also another system for defining algebraically the location of a point or line in a plane. In this, the polar coordinate system, a point is determined by its distance from the origin, O , and by the angle it makes with the axis $O-X$. In Figure 43 the point P is defined by the length of OP , known as the radius vector and

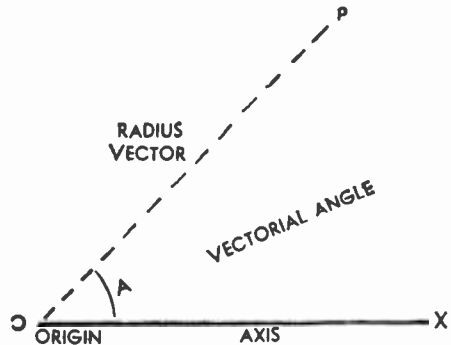

Figure 43.
THE LOCATION OF A POINT BY POLAR COORDINATES.

In the polar coordinate system any point is determined by its distance from the origin and the angle formed by a line drawn from it to the origin and the $O-X$ axis.

by the angle A the vectorial angle. We give these data in the following form

$$P = 3 \angle 60^\circ$$

Polar coordinates are used in radio chiefly for the plotting of directional properties of microphones and antennas. A typical example of such a directional characteristic is shown in Figure 44. The radiation of the antenna represented here is proportional to the distance of the characteristic from the origin for every possible direction.

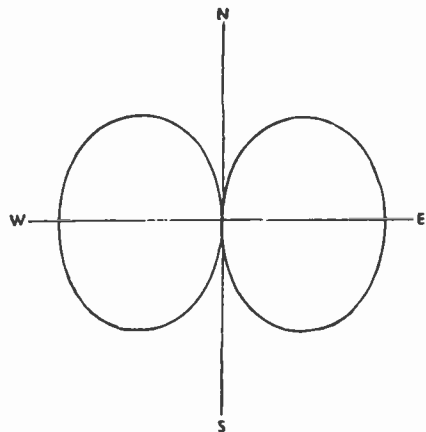

Figure 44.
THE RADIATION CURVE OF AN ANTENNA.

Polar coordinates are used principally in radio work for plotting the directional characteristics of an antenna where the radiation is represented by the distance of the curve from the origin for every possible direction.

Reactance Calculations

In audio frequency calculations, an accuracy to better than a few per cent is seldom required, and when dealing with calculations involving inductance, capacitance, resonant frequency, etc., it is much simpler to make use of reactance-frequency charts such as those in figures 40 and 41 rather than to wrestle with a combination of unwieldy formulas. From these charts it is possible to determine the reactance of a condenser or coil if the capacitance or inductance is known, and vice versa. It follows from this that resonance calculations can be made directly from the chart, because resonance simply means that the inductive and capacitive reactances are equal. The capacity required to resonate with a given inductance, or the inductance required to resonate with a given capacity, can be taken directly from the chart.

While the chart may look somewhat formidable to one not familiar with charts of this type, its application is really quite simple, and can be learned in a short while. The following example should clarify its interpretation.

For instance, following the lines to their intersection, we see that 0.1 hy. and 0.1 μ fd. intersect at approximately 1,500 cycles and 1,000 ohms. Thus, the reactance of either the coil or condenser taken alone is about 1000 ohms, and the resonant frequency about 1,500 cycles.

To find the reactance of 0.1 hy. at, say, 10,000 cycles, simply follow the inductance line diagonally up towards the upper left till it intersects the horizontal 10,000 kc. line. Following vertically downward from the point of intersection, we see that the reactance at this frequency is about 6000 ohms.

To facilitate use of the chart and to avoid errors, simply keep the following in mind: The vertical lines indicate reactance in ohms, the horizontal lines always indicate the frequency, the diagonal lines sloping to the lower right represent inductance, and the diagonal lines sloping toward the lower left indicate capacitance. Also remember that the scale is *logarithmic*. For instance, the next horizontal line above 1000 cycles is 2000 cycles. Note that there are 9, not 10, divisions between the heavy lines. This also should be kept in mind when interpolating between lines when best possible accuracy is desired; halfway between the line representing 200 cycles and the line representing 300 cycles is *not* 250 cycles, but approximately 230 cycles. The 250 cycle point is approximately 0.7 of the way between the 200 cycle line and the 300 cycle line, rather than halfway between.

Use of the chart need not be limited by the physical boundaries of the chart. For instance, the 10- μ fd. line can be extended to find where

it intersects the 100-hy. line, the resonant frequency being determined by projecting the intersection horizontally back on to the chart. To determine the reactance, the logarithmic ohms scale must be extended.

R. F. Tank Circuit Calculations When winding coils for use in radio receivers and transmitters, it is desirable to be able to determine in advance the full coil specifications for a given frequency. Likewise, it often is desired to determine how much capacity is required to resonate a given coil so that a suitable condenser can be used.

Fortunately, extreme accuracy is not required, except where fixed capacitors are used across the tank coil with no provision for trimming the tank to resonance. Thus, even though it may be necessary to estimate the stray circuit capacity present in shunt with the tank capacity, and to take for granted the likelihood of a small error when using a chart instead of the formula upon which the chart was based, the results will be sufficiently accurate in most cases, and in any case give a reasonably close point from which to start "pruning."

The inductance required to resonate with a certain capacitance is given in the chart in figure 41. By means of the r.f. chart, the inductance of the coil can be determined, or the capacitance determined if the inductance is known. When making calculations, be sure to allow for stray circuit capacity, such as tube interelectrode capacity, wiring, sockets, etc. This will normally run from 5 to 25 micro-microfarads, depending upon the components and circuit.

To convert the inductance in microhenries to physical dimensions of the coil, or vice versa, the nomograph chart in figure 45 is used. A pin and a straightedge are required. The inductance of a coil is found as follows:

The straightedge is placed from the correct point on the turns column to the correct point on the diameter-to-length ratio column, the latter simply being the diameter divided by the length. Place the pin at the point on the plot axis column where the straightedge crosses it. From this point lay the straightedge to the correct point on the diameter column. The point where the straightedge intersects the inductance column will give the inductance of the coil.

From the chart, we see that a 30 turn coil having a diameter-to-length ratio of 0.7 and a diameter of 1 inch has an inductance of approximately 12 microhenries. Likewise any one of the four factors may be determined if the other three are known. For instance, to determine the number of turns when the desired in-

Figure 45. COIL CALCULATOR NOMOGRAPH

For single layer solenoid coils, any wire size. See text for instructions.

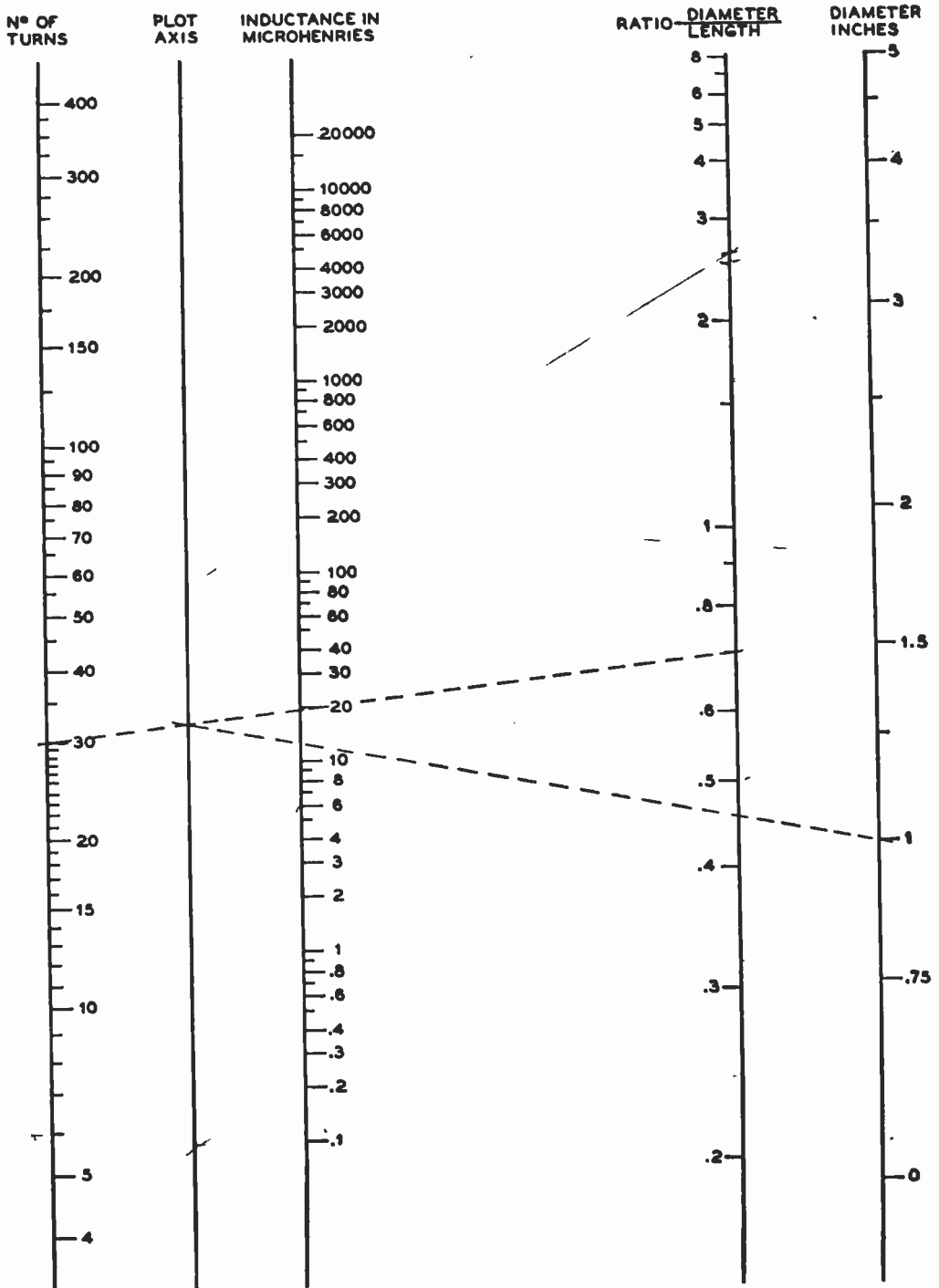

ductance, the D/L ratio, and the diameter are known, simply work backwards from the example given. In all cases, remember that the straightedge reads either turns and D/L ratio, or it reads inductance and diameter. It can read no other combination.

The actual wire size has negligible effect upon the calculations for commonly used wire sizes (no. 10 to no. 30). The number of turns of insulated wire that can be wound per inch (solid) will be found in a copper wire table.

Significant Figures

In most radio calculations, numbers represent quantities which were obtained by measurement. Since no measurement gives absolute accuracy, such quantities are only approximate and their value is given only to a few significant figures. In calculations, these limitations must be kept in mind and one should not finish for instance with a result expressed in more significant figures than the given quantities at the beginning. This would imply a greater accuracy than actually was obtained and is therefore misleading, if not ridiculous.

An example may make this clear. Many ammeters and voltmeters do not give results to closer than 1/4 ampere or 1/4 volt. Thus if we have 2 1/4 amperes flowing in a d.c. circuit at 6 3/4 volts, we can obtain a theoretical answer by multiplying 2.25 by 6.75 to get 15.1875 watts. But it is misleading to express the answer down to a ten-thousandth of a watt when the original measurements were only good to 1/4 ampere or volt. The answer should be expressed as 15 watts, not even 15.0 watts. If we assume a possible error of 1/8 volt or ampere (that is, that our original data are only correct to the nearest 1/4 volt or ampere) the true power lies between 14.078 (product of 2 1/8 and 6 5/8) and 16.328 (product of 2 3/8 and 6 7/8). Therefore, any third significant figure would be misleading as implying an accuracy which we do not have.

Conversely, there is also no point to calculating the value of a part down to 5 or 6 significant figures when the actual part to be used cannot be measured to better than 1 part in one hundred. For instance, if we are going to use 1% resistors in some circuit, such as an ohmmeter, there is no need to calculate the value of such a resistor to 5 places, such as 1262.5 ohm. Obviously, 1% of this quantity is over 12 ohms and the value should simply be written as 1260 ohms.

There is a definite technique in handling these approximate figures. When giving values obtained by measurement, no more figures are

given than the accuracy of the measurement permits. Thus, if the measurement is good to two places, we would write, for instance, 6.9 which would mean that the true value is somewhere between 6.85 and 6.95. If the measurement is known to three significant figures, we might write 6.90 which means that the true value is somewhere between 6.895 and 6.905. In dealing with approximate quantities, the added cipher at the right of the decimal point has a meaning.

There is unfortunately no standardized system of writing approximate figures with many ciphers to the left of the decimal point. 69000 does not necessarily mean that the quantity is known to 5 significant figures. Some indicate the accuracy by writing 69 x 10^3 or 690 x 10^2 etc., but this system is not universally employed. The reader can use his own system, but whatever notation is used, the number of significant figures should be kept in mind.

Working with approximate figures, one may obtain an idea of the influence of the doubtful figures by marking all of them, and products or sums derived from them. In the following example, the doubtful figures have been underlined.

$$\begin{array}{r}
 603 \\
 \underline{34.6} \\
 \underline{0.120} \\
 637.720 \quad \text{answer: } 638
 \end{array}$$

Multiplication:







$$\begin{array}{r}
 654 \\
 \underline{0.342} \\
 \underline{1308} \\
 \underline{2616} \\
 \underline{1962} \\
 223.668 \quad \text{answer: } 224
 \end{array}
 \qquad
 \begin{array}{r}
 654 \\
 \underline{0.342} \\
 \underline{1962} \\
 \underline{2616} \\
 \underline{1308} \\
 224
 \end{array}$$

It is recommended that the system at the right be used and that the figures to the right of the vertical line be omitted or guessed so as to save labor. Here the partial products are written in the reverse order, the most important ones first.

In division, labor can be saved when after each digit of the quotient is obtained, one figure of the divisor be dropped. Example:

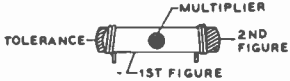
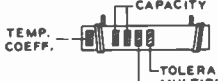
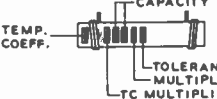
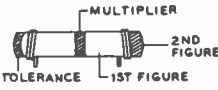
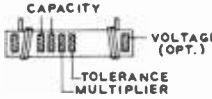
$$\begin{array}{r}
 1.28 \\
 527 \overline{) 673} \\
 \underline{527} \\
 146 \\
 53 \overline{) 146} \\
 \underline{106} \\
 40 \\
 5 \overline{) 40} \\
 \underline{40}
 \end{array}$$

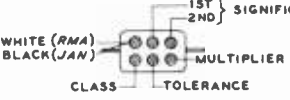
Appendix

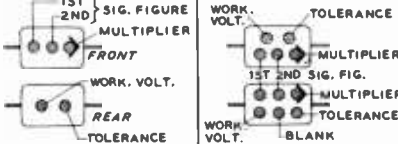
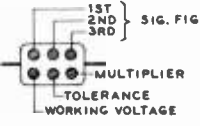
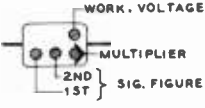
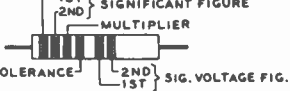
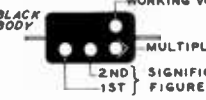
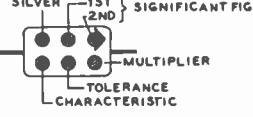
STANDARD COLOR CODE-RESISTORS AND CAPACITORS																																														
<p>AXIAL LEAD RESISTOR BROWN-INSULATED BLACK-NON-INSULATED</p>  <p>1ST & 2ND SIGNIFICANT FIGS. TOLERANCE MULTIPLIER</p> <p>WIRE-WOUND RESISTORS HAVE 1ST DIGIT BAND DOUBLE WIDTH.</p>	<table border="1"> <thead> <tr> <th>INSULATED UNINSULATED COLOR</th> <th>FIRST RING BODY COLOR FIRST FIGURE</th> <th>SECOND RING END COLOR SECOND FIGURE</th> <th>THIRD RING DOT COLOR MULTIPLIER</th> </tr> </thead> <tbody> <tr><td>BLACK</td><td>0</td><td>0</td><td>NONE</td></tr> <tr><td>BROWN</td><td>1</td><td>1</td><td>0</td></tr> <tr><td>RED</td><td>2</td><td>2</td><td>00</td></tr> <tr><td>ORANGE</td><td>3</td><td>3</td><td>,000</td></tr> <tr><td>YELLOW</td><td>4</td><td>4</td><td>0,000</td></tr> <tr><td>GREEN</td><td>5</td><td>5</td><td>00,000</td></tr> <tr><td>BLUE</td><td>6</td><td>6</td><td>000,000</td></tr> <tr><td>VIOLET</td><td>7</td><td>7</td><td>0,000,000</td></tr> <tr><td>GRAY</td><td>8</td><td>8</td><td>00,000,000</td></tr> <tr><td>WHITE</td><td>9</td><td>9</td><td>000,000,000</td></tr> </tbody> </table>	INSULATED UNINSULATED COLOR	FIRST RING BODY COLOR FIRST FIGURE	SECOND RING END COLOR SECOND FIGURE	THIRD RING DOT COLOR MULTIPLIER	BLACK	0	0	NONE	BROWN	1	1	0	RED	2	2	00	ORANGE	3	3	,000	YELLOW	4	4	0,000	GREEN	5	5	00,000	BLUE	6	6	000,000	VIOLET	7	7	0,000,000	GRAY	8	8	00,000,000	WHITE	9	9	000,000,000	<p>DISC CERAMIC RMA CODE</p> <p>5-DOT</p>  <p>3-DOT</p> 
INSULATED UNINSULATED COLOR	FIRST RING BODY COLOR FIRST FIGURE	SECOND RING END COLOR SECOND FIGURE	THIRD RING DOT COLOR MULTIPLIER																																											
BLACK	0	0	NONE																																											
BROWN	1	1	0																																											
RED	2	2	00																																											
ORANGE	3	3	,000																																											
YELLOW	4	4	0,000																																											
GREEN	5	5	00,000																																											
BLUE	6	6	000,000																																											
VIOLET	7	7	0,000,000																																											
GRAY	8	8	00,000,000																																											
WHITE	9	9	000,000,000																																											
<p>RADIAL LEAD DOT RESISTOR</p>  <p>TOLERANCE MULTIPLIER 1ST FIGURE 2ND FIGURE</p>	<p>5-DOT RADIAL LEAD CERAMIC CAPACITOR</p>  <p>TEMP. COEFF. CAPACITY TOLERANCE MULTIPLIER</p>	<p>EXTENDED RANGE TC CERAMIC HICAP</p>  <p>TEMP. COEFF. CAPACITY TOLERANCE MULTIPLIER TC MULTIPLIER</p>																																												
<p>RADIAL LEAD (BAND) RESISTOR</p>  <p>MULTIPLIER TOLERANCE 1ST FIGURE 2ND FIGURE</p>	<p>BY-PASS COUPLING CERAMIC CAPACITOR</p>  <p>CAPACITY VOLTAGE (OPT.) TOLERANCE MULTIPLIER</p>	<p>AXIAL LEAD CERAMIC CAPACITOR</p>  <p>TEMP. COEFF. CAPACITY MULTIPLIER TOLERANCE</p>																																												
MOLDED MICA TYPE CAPACITORS																																														
<p>CURRENT STANDARD CODE</p>  <p>WHITE (RMA) BLACK (JAN) CLASS TOLERANCE 1ST } SIGNIFICANT FIGURE 2ND }</p> <p>JAN 8 1948 RMA CODE</p>	<p>RMA 3-DOT (OBSOLETE) RATED 500 V.D.C. ± 20% TOL.</p>  <p>MULTIPLIER 2ND } SIGNIFICANT FIG. 1ST }</p>	<p>BUTTON SILVER MICA CAPACITOR</p>  <p>CLASS TOLERANCE MULTIPLIER 1ST DIGIT 2ND DIGIT 3RD DIGIT</p>																																												
<p>RMA 5-DOT CODE (OBSOLETE)</p>  <p>1ST } SIG. FIGURE 2ND } MULTIPLIER FRONT TOLERANCE WORK. VOLT. REAR TOLERANCE WORK. VOLT.</p> <p>1ST 2ND SIG. FIG. MULTIPLIER TOLERANCE WORK. VOLT. BLANK</p>	<p>RMA 6-DOT (OBSOLETE)</p>  <p>1ST } SIG. FIGURE 2ND } 3RD } MULTIPLIER TOLERANCE WORKING VOLTAGE</p>	<p>RMA 4-DOT (OBSOLETE)</p>  <p>WORK. VOLTAGE MULTIPLIER 2ND } SIG. FIGURE 1ST }</p>																																												
MOLDED PAPER TYPE CAPACITORS																																														
<p>TUBULAR CAPACITOR NORMALLY STAMPED FOR VALUE</p>  <p>1ST } SIGNIFICANT FIGURE 2ND } MULTIPLIER TOLERANCE 2ND } SIG. VOLTAGE FIG. 1ST }</p> <p>A 2-DIGIT VOLTAGE RATING INDICATES MORE THAN 900 V. ADD 2 ZEROS TO END OF 2 DIGIT NUMBER.</p>	<p>MOLDED FLAT CAPACITOR COMMERCIAL CODE</p>  <p>BLACK BODY WORKING VOLTS MULTIPLIER 2ND } SIGNIFICANT FIGURE 1ST }</p>	<p>JAN CODE CAPACITOR</p>  <p>SILVER 1ST } SIGNIFICANT FIG. 2ND } MULTIPLIER TOLERANCE CHARACTERISTIC</p>																																												

STANDARD COLOR CODE FOR RESISTORS AND CAPACITORS

The standard code provides the necessary information required to properly identify color coded resistors and capacitors. Refer to the color code for numerical values and the number of zeros (or multiplier) assigned to the colors used. A fourth color band on resistors determines the tolerance rating as follows: Gold = 5%, silver = 10%. Absence of the fourth band indicates a 20% tolerance rating.

Tolerance rating of capacitors is determined by the color code. For example: Red = 2%, green = 5%, etc. The voltage rating of capacitors is obtained by multiplying the color value by 100. For example: Orange = 3 × 100, or 300 volts.

AIRWOUND INDUCTORS									
COIL DIA. INCHES	TURNS PER INCH	B & W	AIR DUX	INDUCTANCE μH	COIL DIA. INCHES	TURNS PER INCH	B & W	AIR DUX	INDUCTANCE μH
1/2	4	3001	404T	0.18	1 1/4	4	—	1004	2.75
	6	—	406T	0.40		6	—	1006	6.30
	8	3002	408T	0.72		8	—	1008	11.2
	10	—	410T	1.12		10	—	1010	17.5
	16	3003	416T	2.90		16	—	1016	42.5
	32	3004	432T	12.0		4	—	1204	3.9
5/8	4	3005	504T	0.28	1 1/2	6	—	1206	8.8
	6	—	506T	0.62		8	—	1208	15.6
	8	3006	508T	1.1		10	—	1210	24.5
	10	—	510T	1.7		16	—	1216	63.0
	16	3007	516T	4.4		4	—	1404	5.2
	32	3008	532T	18.0		6	—	1406	11.8
3/4	4	3009	604T	0.39	1 3/4	8	—	1408	21.0
	6	—	606T	0.87		10	—	1410	33.0
	8	3010	608T	1.57		16	—	1416	85.0
	10	—	610T	2.45		4	—	1604	6.6
	16	3011	616T	6.40		6	—	1606	15.0
	32	3012	632T	26.0		8	3900	1608	26.5
1	4	3013	804T	1.0	2	10	3907-1	1610	42.0
	6	—	806T	2.3		16	—	1616	108.0
	8	3014	808T	4.2		4	—	2004	10.1
	10	—	810T	6.6		6	3905-1	2006	23.0
	16	3015	816T	16.8		6	3906-1	2008	41.0
	32	3016	832T	68.0		10	—	2010	108.0
NOTE: COIL INDUCTANCE APPROXIMATELY PROPORTIONAL TO LENGTH. I.E., FOR 1/2 INDUCTANCE VALUE, TRIM COIL TO 1/2 LENGTH.									
					3	4	—	2404	14.0
						6	—	2406	31.5
						8	—	2408	56.0
						10	—	2410	69.0

Copper Wire Table

Gauge No. B. & S.	Diam. in Mils ¹	Circular Mil Area	Turns per Linear Inch ²		D.C.C.	S.C.C.	Turns per Square Inch ²		Feet per Lb.		Ohms per 1000 ft. 25° C.	Correct Capacity at 1500 C.M. per Amp. ³	Diam. in mm.
			Enamel	S.S.C.			D.S.C. or S.C.C.	D.C.C.	Enamel	D.C.C.			
1	289.3	82690	—	—	—	—	—	—	3.947	—	1264	55.7	7.348
2	257.6	66370	—	—	—	—	—	—	4.977	—	1593	48.1	6.544
3	229.4	52640	—	—	—	—	—	—	6.276	—	2009	35.0	5.827
4	204.3	41740	—	—	—	—	—	—	7.914	—	2533	27.7	5.189
5	181.9	33100	—	—	—	—	—	—	9.980	—	3195	22.0	4.621
6	162.0	26250	—	—	—	—	—	—	12.58	—	4028	17.5	4.115
7	144.3	20820	—	—	—	—	—	—	15.87	—	5080	13.8	3.665
8	128.5	16510	7.6	—	—	—	—	—	20.01	—	6405	11.0	3.264
9	114.4	13090	8.6	8.2	7.1	—	—	—	25.23	—	8077	8.7	2.906
10	101.9	10380	9.6	9.3	8.9	8.5	84.8	—	31.82	—	1.018	6.9	2.588
11	90.74	8234	10.7	10.3	9.8	11.0	105	80.0	40.12	30.9	1.284	5.5	2.305
12	80.81	6530	12.0	11.5	10.9	136	131	97.5	50.59	48.9	1.619	4.4	2.053
13	71.96	5178	13.5	12.8	12.0	170	162	150	63.80	61.5	2.042	3.5	1.828
14	64.08	4107	15.0	14.2	13.8	211	198	183	80.44	77.3	2.575	2.7	1.628
15	57.07	3257	16.8	15.8	14.7	262	250	223	101.4	97.3	3.247	2.2	1.450
16	50.82	2583	18.9	17.9	16.4	321	306	271	127.9	119	4.094	1.7	1.291
17	45.26	2048	21.2	19.9	18.1	397	379	329	161.3	150	5.163	1.3	1.150
18	40.30	1624	23.6	22.0	19.8	493	454	399	203.4	188	6.510	1.1	1.024
19	35.89	1288	26.4	24.4	21.8	592	553	479	256.5	237	8.210	.86	.9116
20	31.96	1022	29.4	27.0	23.8	775	725	625	323.4	298	10.35	.68	.8118
21	28.36	816.1	32.7	29.8	26.0	940	895	754	407.8	370	13.05	.54	.7230
22	25.35	642.5	37.0	34.1	30.0	1150	1070	910	514.2	461	16.46	.43	.6438
23	22.57	509.5	40.5	37.6	31.6	1400	1300	1080	648.7	584	20.76	.34	.5733
24	20.10	404.0	46.3	43.5	38.6	1700	1610	1360	817.7	745	26.17	.27	.5106
25	17.90	320.4	50.4	45.9	41.8	2060	1910	1510	1031	903	33.00	.21	.4547
26	15.94	254.1	58.0	55.6	45.0	2500	2300	1750	1300	1118	41.62	.17	.4049
27	14.20	201.5	64.9	61.5	48.5	3030	2780	2020	1639	1422	52.46	.13	.3606
28	12.64	159.8	72.7	68.6	51.8	3670	3350	2310	2067	1759	66.17	.11	.3211
29	11.26	126.7	81.6	74.8	55.2	4300	3900	2700	2607	2207	83.44	.084	.2839
30	10.03	100.5	90.5	83.3	58.5	5040	4660	3020	3287	2534	105.2	.067	.2546
31	8.928	79.70	101.	92.0	62.6	5920	5280	3280	4145	2768	132.7	.053	.2268
32	7.950	63.21	113.	101.	66.3	7060	6250	3630	5227	3137	167.3	.042	.2019
33	7.080	50.13	127.	110.	70.0	8120	7360	4250	6591	3337	211.0	.033	.1798
34	6.305	39.75	143.	120.	73.5	9600	8310	5000	8310	4168	266.0	.026	.1601
35	5.615	31.52	158.	132.	77.0	10900	8700	5700	10480	4737	335.0	.021	.1426
36	5.000	25.00	175.	143.	80.3	12200	10700	6300	13210	5334	423.0	.017	.1270
37	4.453	19.83	198.	154.	83.6	—	—	—	16660	9309	533.4	.013	.1131
38	3.965	15.72	224.	166.	86.6	—	—	—	21010	10666	672.6	.010	.1007
39	3.531	12.47	248.	181.	89.7	—	—	—	26500	11907	848.1	.008	.0897
40	3.145	9.88	282.	194.	—	—	—	—	33410	14222	1069	.006	.0799

¹A mil is 1/1000 (one thousandth) of an inch.
²The figures given are approximate only, since the thickness of the insulation varies with different manufacturers.
³The current-carrying capacity at 1000 C.M. per ampere is equal to the circular-mil area (Column 3) divided by 1000.

CONVERSION TABLE — UNITS OF MEASUREMENT		
MICRO = (μ) ONE-MILLIONTH		KILO = (K) ONE THOUSAND
MILLI = (m) ONE-THOUSANDTH		MEGA = (M) ONE MILLION
TO CHANGE FROM	TO	OPERATOR
UNITS	MICRO-UNITS	$\times 1,000,000$ or $\times 10^6$
	MILLI-UNITS	$\times 1,000$ or $\times 10^3$
	KILO-UNITS	$\div 1,000$ or $\times 10^{-3}$
	MEGA-UNITS	$\div 1,000,000$ or $\times 10^{-6}$
MICRO-UNITS	MILLI-UNITS	$\div 1,000$ or $\times 10^{-3}$
	UNITS	$\div 1,000,000$ or $\times 10^{-6}$
MILLI-UNITS	MICRO-UNITS	$\times 1,000$ or $\times 10^3$
	UNITS	$\div 1,000$ or $\times 10^{-3}$
KILO-UNITS	MEGA-UNITS	$\div 1,000$ or $\times 10^{-3}$
	UNITS	$\times 1,000$ or $\times 10^3$
MEGA-UNITS	KILO-UNITS	$\times 1,000$ or $\times 10^3$
	UNITS	$\times 1,000,000$ or $\times 10^6$

COMPONENT COLOR CODING	
<u>POWER TRANSFORMERS</u>	
PRIMARY LEADS	BLACK
IF TAPPED:	
COMMON	BLACK
TAP	BLACK/YELLOW
END	BLACK/RED
HIGH VOLTAGE WINDING	RED
CENTER-TAP	RED/YELLOW
RECTIFIER FILAMENT WINDING	YELLOW
CENTER-TAP	YELLOW/BLUE
FILAMENT WINDING N° 1	GREEN
CENTER-TAP	GREEN/YELLOW
FILAMENT WINDING N° 2	BROWN
CENTER-TAP	BROWN/YELLOW
FILAMENT WINDING N° 3	SLATE
CENTER-TAP	SLATE/YELLOW
<u>I-F TRANSFORMERS</u>	
PLATE LEAD	BLUE
B+ LEAD	RED
GRID (OR DIODE) LEAD	GREEN
A-V-C (OR GROUND) LEAD	BLACK
<u>AUDIO TRANSFORMERS</u>	
PLATE LEAD (PRI.)	BLUE OR BROWN
B+ LEAD (PRI.)	RED
GRID LEAD (SEC.)	GREEN OR YELLOW
GRID RETURN (SEC.)	BLACK

Index

A

- A-f power amplifiers, 160-165
- Addition, 844, 850
- Airwound inductors, 886
- Algebra, 849-856
- Alternating current, 50-64
 - alternators, 51
 - capacitive reactance, 56
 - complex quantities, 59-62
 - addition, 59
 - multiplication, 60
 - Ohm's law, 60
 - cycle, 50
 - equivalent circuit, 63
 - frequency, 50
 - frequency spectrum, 50
 - generation of, 51
 - impedance, 57
 - impedance diagram, 58
 - induction, 51
 - inductive reactance, 55
 - j* operator, 58
 - Ohm's law, 55
 - parallel RLC circuit, 63
 - peak, RMS, effective, 55
 - phase, 57
 - polar notation, 58
 - radian notation, 53
 - reactances in combination, 57
 - rectified, 54
 - resistance and reactance, 62
 - series RLC circuit, 59
 - sine wave, 52
 - vector, 52
 - voltage dividers, 63
- Alternators, 51
- Aluminum, working with, 833
- Amateur bands, 16-18
- Amateur radio, 13
- Ampere, 28
- Amplifier calculations,
 - class-C, 175-180
- Amplitude distortion, 145
- Amplitude modulation, 309, 312-318
 - cathode-follower, 316
 - constant-efficiency, 312
 - grid, 314
 - high-efficiency, 325
 - impedance, screen-grid, 316
 - linear amplifier, 313
 - screen-grid, 315
 - speech clipping, 317
 - suppressor-grid, 318
 - tuning, 315
 - variable-efficiency, 312
- Amplitude-modulation
 - equipment, 753-762
 - clipper-amplifier, 760-762
 - modulation, 753-756
 - modulators, 756-760
 - tetrode, 756-758
 - triode class-B, 758-760
- Anode, 83
- Antenna and transmission-line
 - instrumentation, 812-821
- Antennascope, 816-818
 - directional coupler, 812
 - monimatch, 818
 - reflectometer, 819
 - r-f impedance bridge, 812
 - slotted line, 812
 - SWR bridge, 814-816
- Antennas, 473-511, 512-531, 532-554
 - broadside arrays, 521-526
 - combination, 529-531
 - corner-reflector, 542-544
 - coupling, 502-507
 - Cubical Quad beam, 526-528
 - current feed, 495
 - dipole-array, 547
 - directive, 512-514
 - Discone, 539
 - double-Bruce array, 523
 - double-skeleton cone, 537
 - end-fire directivity, 528
 - flat-top beam, 529
 - ground connection, 479
 - ground-plane, 478
 - helical beam, 540
 - horizontal, 473-477
 - horizontally polarized, 535
 - horn-type, 542-544
 - insulation, 502, 534
 - linear r-f transformers, 496
 - log-periodic, 545-548
 - long-wire radiators, 514
 - Marconi, 479
 - matching nonresonant lines, 493
 - multiband, 483-493
 - multiwire doublets, 494
 - polarization, 534
 - radiator cross section, 533
 - requirements, 532
 - rhombic, 517-519
 - space-conserving, 481-483
 - stacked-dipole, 519-521
 - stacked-sleeve, 537-539
 - supports, 499-502
 - T-match, 495
 - transmission lines, 533
 - Triplex beam, 529
 - tuner, single-wire, 507-511
 - Vee, 515
 - vertical, 477
 - vertical-polarized, 536
 - vhf and uhf, 532-554
 - vhf dimensions, 535
 - vhf horizontal rhombic, 544
 - voltage feed, 495
 - water-pipe ground, 480
 - X-array, 522
 - yagi, 547-554
- Antenna radiation, 447, 458
 - bandwidth, 449
 - directivity, 455
 - efficiency, 454
 - feed-point impedance, 453
 - general characteristics, 488
 - ground losses, 454
 - ground resistance, 454
 - harmonic resonance, 451
 - impedance, 453
 - length-to-diameter ratio, 450
 - Marconi, 453
 - physical length of, 449
 - polarization, 448
 - resonance, 451
- Antennas, horizontal, 473-477
 - center-fed, 474-477
 - end-fed, 473
 - multiwire doublets, 476
 - tuned doublet, 474
 - Zepp system, 474
- Antennas, mobile work, 585-591
 - all-band, 587
 - antenna trimmer, 585
 - loaded whip, 587-589
- Antennas, rotary-beam, 555-574
 - broadside array, 555
 - indication of direction, 571
 - lumped baluns, 573
 - parasitic beam, 555-557
 - rotatable arrays, 568
 - three-band beams, 572
 - three-element array, 557-559
 - element length, 558
 - material, 558
 - spacing, 558
 - stacking of yagi arrays, 559
 - tuning the array, 569
 - unidirectional arrays, 565-568
 - yagi arrays, 559-565
- Antennascope, 816-818

- Appendix, 885-888
- Arithmetic, 842-849
- Atomic number, 26
- Atoms, 26
- Audio amplifiers, 158
- Audio peak limiting, 211-213
- Autodyne detector, 21
- Automatic gain control, 243
- Autotransformer, 75, 431
- B**
- Bandwidth, 310, 458
- Balanced modulator, 368
- Beam-power tubes, 95
- B-H curve, 44
- Bias stabilization, 122
- Blocking oscillator, 216
- Brassboard, 831
- Breadboarding, 831
- Bridge rectifier, 769
- Broadband balun, 472
- Broadcast interference, 421-425
 - blanketing, 421
 - classification, 421
 - image interference, 423
 - low-pass filters, 424
 - phantoms, 421-423
 - power-line interference, 426
 - receivers, 423
 - stereo interference, 425
 - telephone interference, 425
 - volume-control shafts, 423
- C**
- Cancellation, 849
- Capacitance, 36-42
- Capacitances, tank-circuit, 284-288
- Capacitive reactance, 56
- Capacitors, 36-42, 398-400
 - bypass, 398
 - variable air, 399
- Carrier, 258
 - modulating, 258
 - radiating, 258
- Cathode, 83
- Cathode bias, 144
- Cathode-driven amplifier
 - design, 709-714
- Cathode-follower power amplifiers, 165
- Cathode keying, 438
- Cathode modulation, 323
- Cathode-ray tube, 102-105
 - accelerating anode, 103
 - construction, 103
 - electromagnetic CRT, 104
 - electromagnetic deflection, 105
 - electrostatic deflection, 103
 - operation, 102
- phosphors, 105
- trace, 105
- Chassis layout, 834
- Circuit boards, homemade, 838
- Circuit constants
 - measurements, 808-812
 - impedance method, 808
 - r-f bridges, 811
 - substitution method, 809
 - Wagner ground, 810
 - Wheatstone bridge, 809
- Circuits
 - parallel, 31
 - series, 31
 - series-parallel, 31
- Circulating tank current, 68
- Clamping circuits, 214
- Clapp oscillator, 261
- Closed-loop feedback, 219
- Coaxial cable terminations, 839
- Code practice sets, 25
- Coercive force, 45
- Color codes, 855, 888
- Colpitts oscillator, 260, 270
- Components, 841
- Compounds, 26
- Condenser, 36
- conductance, 31
- Conductors, 29
- Constant-current curves, 173
- Constant-k filter, 78
- Continental Code, 18-25
- Controlled-warmup tubes, 107
- Conversion conductance, 98
- Conversion tables, 888
- Converter, 614-634
 - adjustment, 617-619
 - circuit, 615
 - construction, 616
 - FET, 624-634
 - MOSFET, 619-624
 - r-f amplifier, 629-634
- Coordinate systems, 873-874
- Copper wire table, 887
- Core material, 46
- Coulomb, 28
- Counting circuits, 216
- Coupling, coefficient of, 46
- Coupling effect on impedance, 68
- Crystal filters, 371
- Crystal oscillator circuits, 267-273
- Current flow, 28, 96
- Current measurement, 797-812
- Cycle, 50
- D**
- D-c amplifiers, 154
- Decibel, 861-865
- Decimal fractions, 843-844
- Demodulator, 220
- Detector, 220, 243-246
- Dielectric, 37-39
- Differential keying circuits, 442
- Diffused junction transistor, 116
- Diode, 88
 - characteristics, 88
 - electron energy dissipation, 89
 - plate-current saturation, 88
 - power law, 88
- Diode limiters, 211
- Diode mixer, 98
- Distortion products, 382
 - intermodulation distortion, 383
 - r-f amplifier nonlinearity, 382
 - vacuum-tube nonlinearity, 383
- Division, 844-846, 851
- Doherty and Terman-Woodyard amplifiers, 323-325
- E**
- Eccles-Jordan circuit, 215
- Eddy current, 46
- Effective alternating current, 55
- Electric current, 27
- Electric filters, 76-78
- Electrical potential, 27
- Electrolytic capacitors, 42
- Electrolytic conduction, 83
- Electromagnetic energy, 37
- Electromagnetism, 42-47
- Electromotive force, 27
- Electron emission, 83
- Electron Flow, 28
- Electron-ray tubes, 107
- Electrostatic energy, 37
- Electrostatics, 36-42
- Elements, 26
- Emission equation, 87
- Energy, 36
- Epitaxial transistors, 116
- Equations, 853-856
 - first-degree, 853-855
 - quadratic, 855-856
- Equivalent series circuit, 63
- Error cancellation, 219
- Exciters, 386-390, 657-695
 - audio filters, 693-695
 - c-w filter, 694
 - SSB filter, 693
 - broadband, 40-watt, 661-667
 - circuit, 662-665
 - transmitter adjustment, 666
 - transmitter construction, 665
 - general-purpose, 657-661
 - adjustment, 659
 - amplifier construction, 661

amplifier operation, 661
 circuit, 658
 construction, 659
 heterodyne SSB, 660
 PEP linear amplifier, 661
 linear amplifier, 150-watt,
 675-680
 circuit, 675
 layout and assembly, 676-678
 plate circuit, 678
 testing, 679
 SSB, jr., 386
 SSB, 175-watt, 683-693
 bandswitch assembly, 686
 circuit, 684
 dial assembly, 686
 layout, 685
 wiring and testing, 686-693
 Ten-A, 387
 transistorized, 389
 transverter, 2-meter SSB,
 667-675
 circuit, 668-672
 construction and adjustment,
 672-674
 strip-line filter, 674
 tripler/amplifier, 680-683
 construction, 681
 operation, 682
 two-tube, 390

F

Factoring, 851
 Farad, 37
 Feedback, 218-220
 Feedback amplifiers, 166-168
 Field-effect transistor (FET), 116
 Filters
 assembly, 77
 basic, 76
 constant-K, 78
 design techniques, 77
 electric, 76-78
 m-derived, 80-82
 operation, 76
 sections, 76
 Filter-system resonance, 766
 Finishes, 836
 Fixed bias, 144
 Flux, 43
 Flywheel effect, 69
 F-M circuits, direct, 339-342
 adjusting phase shift, 340
 diode modulator, 341
 linearity test, 341
 reactance modulators, 339
 reactance-tube modulators, 340
 stabilization, 340

F-m signals, reception, 345-352
 adapter unit, 350
 design, 348
 Foster-Seeley discriminator, 346
 frequency detector, 345
 limiters, 348
 mobile relays, 351
 pre-emphasis and
 de-emphasis, 349
 ratio detector, 347
 receiver circuitry, 350
 Travis discriminator, 346
 Forced-air cooling, 411
 Forward bias, 110
 Fractions, 846, 847
 Franklin oscillator, 263
 Frequency distortion, 145
 Frequency divider, 216
 Frequency modulation, 334
 bandwidth required, 338
 carrier-wave distortion, 335
 f-m terms, 336
 modulation, 335
 narrow-band transmission, 338
 Frequency multipliers, 281-284
 Frequency of resonance, 65
 Frequency-shift keying
 353, 356, 358
 Frequency spectrum, 50
 Full-wave rectifier, 769
 Functions of angles, 868-870

G

Gas tubes, 105-107
 ion action, 105
 mercury-vapor, 106
 thyatron, 106
 vacuum-tube classifications, 106
 premium, 106
 voltage-regulator, 106
 Germanium, 108
 Grid-bias, 292-294
 cathode, 293
 class-C, 292
 safety, 293
 self, 292
 separate supply, 293
 series screen supply, 294
 zener, 294
 Grid-circuit keying, 439
 Grid-current effect, 97
 Grid limiters, 213
 Grown-junction transistor, 116
 Grid-screen μ factor, 96
 Grounded-grid amplifiers, 281
 Grounds, 402

H

Half-wave rectifier, 768

Hardware, 841
 Harmonic radiation, 414-416
 isolating source of, 416
 nature of, 415
 Hartley oscillator, 259
 Heat exchanger, 115
 Heat sink, 115
 Heater cathode, 86
 Heating effect, 36
 Henry, 45
 Hertz, 51
 Hysteresis, 45, 138
 Hysteresis losses, 46

I

I-f alignment, 205
 I-f circuits, radio, 236-244
 Imaginary numbers, 853
 Impedance, 57, 58, 65, 75
 diagram, 58
 series-resonant circuits, 65
 transformation, 75
 Inductance, 45
 Inductance unit, 45
 Induction, 51
 Inductive reactance, 55
 Inductor, 46, 400-402
 coil placement, 401
 insulation, 401
 r-f chokes, 401
 Input modulation system, 318-323
 Heising, 319
 plate, 319
 plate-and-screen, 321
 power relations, 320
 Insulator, 27, 29
 Instantaneous voltage, 53
 Integrated circuits, 135
 Interelectrode capacitance, 142
 Intermodulation distortion, 193
 Internal resistance, 31
 International Morse Code, 18-25
 Interstage coupling, 296
 capacitive, 296
 inductive, 297
 link, 297
 unity, 297
 Ion, 28
 Iron-core inductors, 47

J

j operator, 58
 Joule, 36
 Junction capacitance, 112
 Junction transistor, 117

K

Kirchoff's Laws, 34
 Klystron, 99-101

L

L and pi networks, 288-292
L/C ratio, 68
Lead inductance effects, 98
Licenses, International regulations, 16
Licenses, operator, 14-16
Licenses, station, 14-16
Limiting circuits, 211-214
 audio peak limiting, 211-213
 diode limiters, 211
 grid limiters, 213
Linearity tracer, 209
Lissajous figures, 201
Loaded and unloaded Q , 69
Loaded whip antennas, 587-589
Logarithmic scales, 819-820
Logarithms, 856-861
 bases, 857
 common, 857
 definition, 856
 properties, 857-859
 tables, 858-861
Low-pass filters, 416-421
 construction of, 417-420
 high-power filter, 420
 half-wave filter, 420

M

Magnetic circuit, 43
Magnetic fields, 42
Magnetism, 42-47
Magnetomotive force, 43
Magnetron, 101
Mercury-vapor tubes, 106
Metallic, 27
Microwave electron tubes, 99-102
 magnetron, 101
 power Klystron, 99
 reflex Klystron, 100
 traveling-wave tube, 102
Miller effect, 142, 238
Miscellaneous tube types, 107
 controlled-warmup, 107
 electron-ray, 107
Mixer and converter tubes, 97
 conversion conductance, 98
 diode mixers, 98
 pentode mixers, 98
 triode mixers, 98
Mobile converters, 575-577
Mobile equipment, 589-591
Mobile power sources, 577-580
 alternator, 578
 batteries, 579
Mobile work, antennas for 585-591
Modulated-wave pattern, 205

Modulation, mechanics of, 310
 capability, 311
 measurement, 311
 percentage, 309, 311
 waveform dissimilarity, 312
Modulation percentage, 309, 311
Molecules, 26
Monimatch, 818
Morse Code, 18-25
Mounting components, 836
Multivibrators, 214-216
Mutual inductance, 45

N

Net reactance, 57
Noise factor, radio, 226-228
Noise generator, 822-828
 audio generator, 827
 capacitance meter, 826
 silicon crystal, 823
 silicon diode, 822
 test set, 826
 transistor tester, 824-826
 use of, 824
Noise suppression, radio, 246-250
Nomographs, 878-884
Nonmetallic, 26
Nonsinusoidal waves, 70-73
 miscellaneous inputs, 73
 other waveforms, 71
 peaked wave, 71
 RC differentiator, 72
 sawtooth wave, 71
 sawtooth-wave input, 72
 square wave, 70
 square-wave input, 72
 square-wave test, 73
 transient circuits, 71
 wave composition, 70
Notation of numbers, 842

O

Ohm, 28, 29, 31, 32, 44, 55, 60
Operator licenses, 14-16
Oscillators, 258
 Clapp, 261
 Colpitts, 259
 crystal oscillator, circuits, 267-273
 crystal switching, 270
 inductive loading, 272
 pentode harmonic crystal, 268
 6CL6 oscillator, 270
 triode overtone, 271
 tuned-plate, 267
 tuning 270
 electron-coupled, 261
Franklin, 263

frequency multipliers, 281-284
 angle of flow, 282
 push-pull, 283
 push-push, 283
 grounded-grid, 281
Hartley, 259
L- and pi networks, 288-292
 negative-resistance, 262
 neutralizing procedures, 277
 cancellation of screen-lead inductance, 280
 passive, 277
 problems, 281
 screen-grid, 278-280
 quartz-crystal, 264-267
 crystal drive level, 267
 crystal holders, 265
 overtone-cut crystals, 266
 piezoelectric effect, 264
 practical quartz crystals, 265
 resonance, 267
 r-f amplifiers, 273
 cathode-driven, 276
 classes, 273
 grid excitation, 273
 grid-modulated, 273
 grid neutralization, 275
 neutralization, 274
 push-pull neutralization, 275
 shunt or coil, 276
 split-stator, 275
 Seiler oscillator, 262
 stability, 264
 t.p.t.g., 260
 transitron, 262
 Vackar oscillator, 262
 VFO transmitter controls, 264
Oscilloscope, 195-210
 i-f alignment, 205
 linearity tracer, 209
 Lissajous figures, 201
 modulated-wave pattern, 205
 power supply, 199
 resonance curve, 206
 single sideband, 208
 sweep amplifier, 199
 sweep generator, 198
 time-base circuitry, 197
 blanking circuit, 197
 sweep-trigger circuit, 197
 trapezoidal pattern, 205
 waveforms, 199, 204
Oxide-coated filament, 86

P

Parallel circuits, 31
Parallel resistance and reactance, 62

- Parallel resonance, 67
 - Parallel RLC circuit, 63
 - Parallel tube circuits, 298
 - Parametric oscillation, 138
 - Parasitic oscillation, 405-411
 - checking for, 409
 - elimination of vhf, 407
 - in r-f amplifiers, 405
 - low-frequency, 406
 - test for, 410
 - tetrode screening, 409
 - with beam tetrodes, 407-409
 - with triodes, 407
 - Parasitic resonances, 404
 - Peak alternating current, 55
 - Peaked wave, 71
 - PEP supply for SSB, 784
 - Permeability, 44
 - Pentode, 95
 - Pentode amplifiers, 157
 - Pentode mixers, 98
 - Phase distortion, 145
 - Phase inverters, 152-154
 - cathode-coupled, 153
 - floating paraphase, 152
 - hot-cathode, 152
 - voltage-divider, 153
 - Phase modulation, 334, 342-345
 - measurement of deviation, 343-345
 - phase modulator, 343
 - Phase-shift oscillator, 218
 - Phasing SSB exciter, 372-377
 - a-f phasing, 376
 - r-f phasing, 375
 - Photoelectric emission, 83
 - Pierce harmonic circuit, 269
 - Piezoelectric effect, 264
 - Plate circuit, radio, 228-230
 - Plate-modulation system, 318
 - Point-contact transistor, 116
 - Polar coordinates, 871-873, 881
 - Polar notation, 58
 - Potential difference, 27
 - Potential energy, 37
 - Power, 35
 - Power amplifier, hi-fi and vhf, 696-752
 - design, 296-714
 - cathode-driven, 709-714
 - tetrode, 701-709
 - triode, 697-701
 - high-gain amplifier, 740-717
 - circuitry, 740-743
 - construction, 743-747
 - linear amplifier, 713-740, 747-752
 - economy, 714-719
 - 500Z 2KW, 725-734
 - kilowatt, 747-752
 - KW-1, 719-725
 - triband KW-2, 734-740
 - Power-line interference, 426
 - Power measurements, 806-808
 - calorimeter, 807
 - dummy load, 807
 - thermocouple, 806
 - thermogalvanometer, 806
 - Power supply, 199, 763-796
 - components, 767
 - bleeder resistors, 768
 - filter capacitors, 767
 - filter-choke coils, 768
 - transformers, 768
 - general-purpose, 790-796
 - IVS bridge-rectifier, 784-787
 - PEP supply for SSB, 784
 - rectification circuits, 768-775
 - regulated, 787-790
 - requirements, 763-767
 - series diode operation, 777
 - silicon rectifier, 775-777
 - silicon supplies for
 - SSB, 778-784
 - Powers and roots, 847-849, 852-853
 - Powerstat, 431
 - Primary transformer, 73
 - Printed circuits, 838
 - Printed-circuit SSB
 - transceiver, 593-601
 - circuit, 594-597
 - coils, 598
 - layout and assembly, 597
 - testing, 599-601
 - Punching holes, 835
 - Push-pull audio amplifiers, 158
 - Push-pull tube circuits, 298
- Q**
- Quartz-crystal oscillators, 264-267
 - Q variation with frequency, 67
- R**
- Radian, 865-867
 - Radian notation, 53
 - Radiation, 447
 - directivity, 448
 - from an antenna, 447
 - from other sources, 447
 - polarization, 448
 - resistance, 448, 452-458
 - Radio-frequency amplifiers, 273
 - Radio-frequency chokes, 297
 - Radio mathematics and calculations, 842-888
 - Radio receiver, 220-257
 - autodyne detector, 221
 - demodulator, 220
 - detector, 220, 243-246
 - a-c loading
 - audio amplifiers, 246
 - automatic gain control, 243
 - avc in SSB, 245
 - bfo-equipped AVC, 244
 - detectors, 243
 - signal-strength indicators, 245
 - i-f circuits, 236-244
 - beat-frequency oscillators, 242
 - bilateral amplifier, 243
 - crystal filters, 238
 - i-f transformers, 236
 - mechanical filter, 240
 - Miller effect, 238
 - practical filters, 239
 - rejection notch, 239
 - shape factor, 237
 - transfilter, 241
 - noise, 226-228
 - blocking, 229
 - desensitization, 229
 - factor, 226
 - first tuned circuit, 226
 - grid circuit, 226
 - images, 230
 - injection voltage, 229
 - mixer noise, 229
 - plate-circuit coupling, 228
 - spurious products, 228
 - triode mixers, 229
 - tube-input loading, 227
 - noise suppression, 246-250
 - alternative limiter
 - circuit, 249
 - audio limiters, 248
 - Bishop limiter, 248
 - full-wave limiter, 249
 - Lamb limiter, 247
 - noise blanker, 250
 - peak limiter circuits, 248
 - power-line filters, 246
 - peak noise limiters, 247
 - TNS limiter, 249
 - radiotelephony demodulation, 220
 - radiotelegraphy reception, 221
 - receiving accessories, 256
 - product detector, 256
 - Q multiplier, 256
 - receiver adjustment, 254-256
 - bfo adjustment, 255
 - front-end alignment, 256

- i-f alignment, 255
 - i-f with crystal filter, 255
 - instruments, 254
 - superheterodyne alignment, 255
 - TRF alignment, 255
 - regeneration, 221
 - r-f stages, 230
 - cascade amplifier, 231
 - common-base amplifier, 231
 - double conversion, 232
 - nuvistors, 230
 - r-f amplifier, 230
 - vhf range, 230
 - superheterodyne receivers, 221-226
 - arithmetical selectivity, 223
 - advantages, 223
 - converter stage, 224
 - diode mixers, 225
 - frequency choice, 223
 - operation principle, 222
 - superregenerative receivers, 221
 - tuned circuits, 233-236
 - bandspread tuning, 235
 - frequency range, 235
 - impedance and Q , 233
 - input resistance, 234
 - stray circuit capacitance, 235
 - superheterodyne tracking, 234
 - uhf design, 250-254
 - butterfly circuit, 253
 - germanium rectifiers, 254
 - receiver circuits, 253
 - resonant cavities, 251-253
 - transmission line circuits, 250
 - tuning short lines, 251
 - vhf transistors, 254
 - vhf tubes and transistors, 253
 - Radio station layout, 427
 - autotransformers, 431
 - contactors and relays, 429
 - outlet strips, 429
 - power-line standards, 428
 - power systems, 427
 - safety precautions, 434
 - transmitter power output, 430
 - Radio waves, propagation of, 458-466
 - duct formation, 461
 - E layer, 463
 - F₂ layer, 425-426
 - fading, 464
 - ground wave, 459
 - ionospheric propagation, 462
 - meteors and "burst," 466
 - scattered reflections, 465
 - skip distance, 463
 - sky wave, 459
 - space wave, 459
 - stratospheric reflection, 461
 - surface wave, 459
 - tropospheric propagation, 460
 - Radiotelegraphy reception, 221
 - Radiotelephony demodulation, 220
 - Radioteletype, 353
 - RC circuit, 47
 - RC-coupled pentode stages, 147
 - RC-coupled triode stages, 146
 - RC differentiator, 72
 - Reactance calculations, 882-884
 - Receivers, 613, 634-645
 - amateur band, 634-645
 - alignment, 644
 - circuit, 635-640
 - wiring, 641
 - construction, 640
 - Receiver adjustment, radio, 254-256
 - Receiving accessories, radio, 256
 - product detector, 256
 - Q multiplier, 256
 - Reception, SSB, 391-394
 - automatic gain control, 392
 - beam-deflection tube, 393
 - receiver circuitry, 391
 - receivers, 391
 - Rectified alternating current, 54
 - Rectifier circuits, 770
 - Rectifiers, 773
 - Reflectometer, 819
 - Regeneration, 221
 - Relaxation oscillator, 214
 - Reluctance, 43
 - Remote-cutoff tubes, 95
 - Reperforator, 358
 - Residual magnetism, 45
 - Resistance, 28, 31
 - Resistance-capacitance filters, 766
 - Resistance-capacitance oscillators, 217
 - Resistors, 32, 41, 396-398
 - Resonance, 64
 - Resonance curve, 206
 - Resonance, sharpness of, 66
 - Resonant circuits, 64-70
 - circuit Q , 66
 - circulating tank current, 68
 - coupling effect, 68
 - current and voltage, 66
 - flywheel effect, 69
 - frequency, 64
 - impedance, 65
 - L/C ratio in parallel circuits, 68
 - loaded and unloaded Q , 69
 - parallel resonance, 67
 - skin effect, 67
 - "tank" circuit, 67, 70
 - variation of Q , 67
 - voltage across coil, 66
 - Resonant frequency, 64
 - Retentivity, 45
 - Reverse bias, 111
 - R-f energy, generation of, 258-300
 - R-f feedback, 301-308
 - amplifier check, 303
 - circuits, 301
 - neutralization, 303
 - neutralization procedure, 306-308
 - one-stage amplifier, 304
 - parasitic oscillations, 306
 - tests for neutralization, 305
 - two-stage amplifier, 302, 304
 - R-f power amplifiers, 169-173
 - cathode tank, 186
 - class AB, 187-190
 - class B, 180-183
 - class C, 169-180
 - grid voltage, 171
 - grounded-cathode, 183
 - grounded-grid, 183-187, 190-193
 - plate voltage, 171
 - tuned-cathode circuit, 193
 - Right triangles, 867-869
 - Ripple voltage, 765
 - RL circuit, 47
 - RTTY system, 353
 - Ruggedized or premium tubes, 106
- S**
- Safety precautions, station, 434
 - d-c relay operation, 436
 - exposed wires, 434
 - grounds, 434
 - "hot" adjustments, 435
 - protective interlocks, 435
 - relay sequence, 436
 - safety bleeders, 435
 - safety signal and switch, 434
 - Saturation, 44
 - Saturation point, 44
 - Sawtooth wave, 71
 - Sawtooth-wave input, 72
 - SCR devices, 114
 - Screen-grid keying, 440
 - Screen-grid tubes, 94-97
 - beam-power, 95
 - coefficients, 97
 - current flow, 96
 - effect of grid current, 97

- Mu factor, 96
- pentode, 95
- remote-cutoff, 95
- tetrode, 94
- Self-inductance, 45
- Secondary emission, 87
- Secondary transformer, 74
- Seiler oscillator, 262
- Self-controlled oscillators, 258-264
- Semiconductors, 27, 108-141
 - atomic structure, 108
 - conduction mechanism, 109
 - extrinsic, 110
 - forward bias, 110
 - intrinsic, 110
 - junction capacitance, 112
 - PN junction, 109
 - point-contact, 113
 - reverse bias, 111
 - SCR devices, 114
 - thermal considerations, 115
 - thyristor, 114
 - tunnel-diode, 113
 - varactor, 112
 - zener-diode, 111
- Series circuits, 31
- Series-diode gate clipper, 211
- Series-parallel circuits, 31
- Series resonance, 66
- Series RLC circuit, 59
- Shop layout, 840, 841
- Sideband filter, 368, 370-372
 - crystal filters, 371
 - mechanical filters, 372
- Sidebands, 309
- Significant figures, 884
- Silicon, 108
- Silicon power transistors, 136
- Silicon rectifier, 775-777
- Sine wave, 52
- Single-sideband, 208-359
 - linear amplifier, 366
 - medium, 359
 - peak envelope power, 365
 - sideband filter, 362
 - source, 359
 - translator, 359
 - transmission band, 359
 - transmitter, 367
 - balanced modulator, 368
 - carrier oscillator, 367
 - linear amplifier, 368
 - sideband filter, 368
 - speech amplifier, 367
- Single sideband, frequency
 - conversion, 377-382
 - coupled tuned circuits, 381
 - mixer stages, 377
 - problems, 381
 - selective tuned circuits, 379
 - twin-triode mixer, 378
- Skin effect, 67
- Soldering, 836
- Solid-state voltmeters, 805
- Space-charge effect, 87
- Speech clipping, 325-330
 - clipper circuits, 329
 - high-level filters, 330
 - phase-shift correction, 327-329
- Speech compression, 330-333, 383-386
 - ALC circuit, 384
 - automatic load control, 383-385
 - bass suppression, 332
 - modulated-amplifier distortion, 332
- Square root, 848, 849
- Square wave, 70
- Square-wave input, 72
- Square-wave test, 73
- Station licenses, 14-16
- Step-counter, 217
- Stereo interference, 425
- Subtraction, 844, 850-851
- Superheterodyne alignment, 255
- Superheterodyne receivers, 222-226
 - Superregenerative receivers, 221
- Sweep amplifier, 199
- Sweep generator, 198
- Sweep-trigger circuit, 197
- T**
- "Tank" circuit, 67, 70, 284-288
 - capacitances, 284-288
 - air gap, 288
 - effect of loading, 287
 - optimum Q , 287
 - harmonic radiation, 285
 - effective Q , 284
- Tank-circuit efficiency, 70
- Tape perforator, 358
- Telephone interference, 425
- Teleprinter code, 353
- Teleprinting, 353
- Tetrode, 94-97
- Tetrode amplifier design, 701-709
- Tetrode transmitting tube, 294-296
 - clamp tube, 295
 - grid protection, 296
 - screen protection, 295
 - screen supply, 295
- Thermionic emission, 83-87
 - equation, 87
 - heater cathode, 86
 - oxide-coated filament, 86
 - secondary, 87
 - space-charge effect, 87
 - tungsten filament, 84
- Thyratron tubes, 106
- Thyristor, 114
- Time-base circuitry, 197
- Time constant, 47
- Time measurements, 821
 - Atomic Time, 821
 - Ephemeris Time, 821
 - Greenwich Mean Time, 821
 - marker oscillators, 822
 - radio time signals, 821
 - Universal Time, 821
- Transceiver, SSB, 394, 614, 645-656
 - single-band SSB, 645-656
 - adjustment, 655
 - alignment, 653-655
 - circuit, 646-649
 - layout and assembly, 649-651
 - transmit operation, 656
 - wiring, 651
- Transformer coupling, 149
- Transformer cutouts, 835
- Transformers, 73-76
 - ampere turns, 75
 - autotransformer, 75
 - impedance transformation, 75
 - leakage reactance, 75
 - primary, 73
 - secondary, 74
 - transformation ratio, 74
 - types of, 74
- Transients, 70-73
- Transient circuits, 71
- Transistor, 108, 116-141
 - analysis, 120
 - audio circuitry, 125
 - bias stabilization, 122
 - bootstrap circuit, 128
 - characteristics, 120
 - circuitry, 124
 - classes, 116
 - complementary-symmetry circuits, 126
 - configurations, 121
 - constant-power, 124
 - cutoff frequencies, 118
 - diffused junction, 116
 - digital and linear IC's, 136
 - epitaxial, 116
 - equivalent circuit, 121
 - field-effect (FET), 116, 133-135
 - grown junction, 116

- handling transistors, 119
 - hysteresis, 138
 - input circuits, 139
 - integrated circuits, 135
 - junction, 117
 - junction field-effect (JFET), 133
 - low-frequency oscillation, 138
 - mode of operation, 140
 - nomenclature, 117
 - oscillators, 131
 - output circuits, 139
 - output curves, 122-124
 - parametric oscillation, 138
 - point contact, 116
 - r-f circuitry, 128-131
 - silicon power transistors, 136
 - symbols, 119
 - transition region, 119
 - Transistor supplies, 580-585
 - operation, 581
 - power rating, 581
 - power transformer, 582
 - self-starting oscillators, 582
 - Transit time effect, 99
 - Transmission lines, 467-472
 - coaxial line, 469
 - line discontinuities, 471
 - nonresonant, 466-470
 - resonant, 466, 470
 - Transmitter control methods, 432
 - Transmitter-distributor unit, 357
 - Transmitter keying, 437, 443
 - Transmitters, 829
 - Transmitting tubes, cooling, 299
 - Trapezoidal pattern, 205
 - Traveling-wave tube, 102
 - Triband sideband transceiver, 601
 - Transmitter alignment, 607-612
 - testing and alignment, 604-607
 - construction, 603
 - circuit, 601-603
 - Trigonometric functions, 868-870
 - Trigonometric tables, 870
 - Trigonometry, 865-873
 - Triode, 89-94
 - amplification factor, 90
 - current flow, 90
 - curves, 91
 - grid action, 89
 - interelectrode capacitance, 94
 - load line, 91
 - plate resistance, 90
 - polarity inversion, 93
 - transconductance, 90
 - tube characteristics, 93
 - Triode amplifiers, 154-157, 697-701
 - Triode mixer, 98
 - Triode overtone oscillators, 271
 - Tube circuits, 298
 - parallel, 298
 - push-pull, 298
 - Tungsten filament, 84
 - Tunnel diode, 113
 - TV interference, in radio, 412-414
 - blocking from 50-MHz, 414
 - high-pass filters, 413
 - spurious emissions elimination, 414
 - taking out signal, 413
 - TV-set overload, 412
 - uhf receiver design, 250-254
 - units of measurements, 888
- V**
- Vackar oscillator, 262
 - Vacuum-tube amplifiers, 142-168
 - a-f power amplifiers, 160-165
 - amplifier response, 147
 - audio amplifiers, 158
 - biasing methods, 144
 - cascaed, 147
 - cathode-follower amplifiers, 165
 - classes and types, 143
 - constants, 142
 - d-c amplifier circuit, 154
 - distortion, 145
 - feedback amplifiers, 166-168
 - grid-resistor bias, 147
 - interelectrode capacitances, 142
 - Loftin-White circuit, 154
 - Miller effect, 142
 - parameters, 142
 - pentode amplifiers, 157
 - phase inverters, 152-154
 - RC-coupled, 146
 - resistance-capacitance coupled, 145-149
 - symbols, 142
 - transformer coupling, 149-152
 - triode amplifiers, 154-157
 - video-frequency amplifiers, 149
 - voltage gain per stage, 146
 - Vacuum-tube classification, 106
 - Vacuum-tube modulators, 370
 - Varactor, 112
 - Variac, 431
 - Vectors, 870-882
 - Vehicular noise suppression, 591-593
 - body static, 592
 - generator "whine," 592
 - ignition noise, 591
 - locating noise sources, 593
 - voltage-regulator "hash", 592
 - wheel static, 592
 - Vertical amplifier, 196
 - Vertical antennas, 477
 - Vhf and uhf antennas, 532-554
 - Video-frequency amplifiers, 149
 - Volt, 29
 - Voltage decay, 49
 - Voltage divider, 33
 - Voltage gradient, 47
 - Voltage measurement, 797-806
 - a-c, v-t voltmeter, 801
 - ammeter, 798
 - bridge-type v.t.v.m., 803-805
 - d-c, v-t voltmeter, 802
 - diode peak voltmeter, 801
 - multirange meter, 799
 - solid-state, 805
 - FET, 805
 - MOSFET, 805
 - vacuum-tube voltmeter, 800
 - voltmeter, 798
 - voltohmeters, 799
 - Voltage regulation, 764
 - Voltage-regulator tubes, 106
 - Volume compression, 330
 - VOX circuitry, 444-446
 - bias control, 446
 - control, 444-446
 - transistor circuit, 446
- W**
- Watt, 36
 - Wave composition, 70
 - Waveforms, 71, 199, 204
 - Winding coils, 837
 - Wire, 400-402
 - coil placement, 401
 - insulation, 401
 - r-f chokes, 401
 - Wire table, 887
 - Work, 36
 - Workshop tools, 829
- Y**
- Yagi antenna, 547-554
 - element lengths, 548
 - construction of array, 550-552
 - tiltable, 550
 - Yagi arrays, 559-565
 - delta match, 562
 - impedance matching, 559
 - rotary-link coupling, 563
 - stub balun, 565
- Z**
- Zener diode, 111